

2. DETAILED MODELING SOLUTIONS: ALL PROBLEMS

[1] Step 1 Modeling

4 spring (truss) elements; 5 nodes; 1 DOF/node

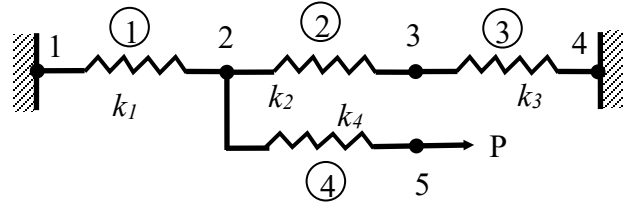

Figure P1

Step 2 Element equations

Element 1

$$[K]^{(1)} = \begin{bmatrix} k_1 & -k_1 \\ -k_1 & k_1 \end{bmatrix} \quad \{u\}^{(1)} = \begin{Bmatrix} u_1 \\ u_2 \end{Bmatrix} \quad \{P\}^{(1)} = \begin{Bmatrix} F_1^{(1)} \\ F_2^{(1)} \end{Bmatrix}$$

$$\text{we get } \begin{bmatrix} k_1 & -k_1 \\ -k_1 & k_1 \end{bmatrix} \begin{Bmatrix} u_1 \\ u_2 \end{Bmatrix} = \begin{Bmatrix} F_1^{(1)} \\ F_2^{(1)} \end{Bmatrix}$$

Similarly we have

$$\text{For element 2 } \begin{bmatrix} k_2 & -k_2 \\ -k_2 & k_2 \end{bmatrix} \begin{Bmatrix} u_2 \\ u_3 \end{Bmatrix} = \begin{Bmatrix} F_2^{(2)} \\ F_3^{(2)} \end{Bmatrix}$$

$$\text{For element 3 } \begin{bmatrix} k_3 & -k_3 \\ -k_3 & k_3 \end{bmatrix} \begin{Bmatrix} u_3 \\ u_4 \end{Bmatrix} = \begin{Bmatrix} F_3^{(3)} \\ F_4^{(3)} \end{Bmatrix}$$

$$\text{For element 4 } \begin{bmatrix} k_4 & -k_4 \\ -k_4 & k_4 \end{bmatrix} \begin{Bmatrix} u_2 \\ u_5 \end{Bmatrix} = \begin{Bmatrix} F_2^{(4)} \\ F_5^{(4)} \end{Bmatrix}$$

Step 3 Assembly

Global stiffness matrix

$$[K] = \begin{bmatrix} k_1 & -k_1 & 0 & 0 & 0 \\ -k_1 & k_1 + k_2 + k_4 & -k_2 & 0 & -k_4 \\ 0 & -k_2 & k_2 + k_3 & -k_3 & 0 \\ 0 & 0 & -k_3 & k_3 & 0 \\ 0 & -k_4 & 0 & 0 & k_4 \end{bmatrix}$$

Global unknowns vector and load vector

$$\{u\} = \begin{Bmatrix} u_1 \\ u_2 \\ u_3 \\ u_4 \\ u_5 \end{Bmatrix} \quad \{P\} = \begin{Bmatrix} F_1^{(1)} \\ F_2^{(1)} + F_2^{(2)} + F_2^{(4)} \\ F_3^{(2)} + F_3^{(3)} \\ F_4^{(3)} \\ F_5^{(4)} \end{Bmatrix} = \begin{Bmatrix} R_1 \\ 0 \\ 0 \\ R_4 \\ P \end{Bmatrix}$$

Global FEM equation

$$\begin{bmatrix} k_1 & -k_1 & 0 & 0 & 0 \\ -k_1 & k_1 + k_2 + k_4 & -k_2 & 0 & -k_4 \\ 0 & -k_2 & k_2 + k_3 & -k_3 & 0 \\ 0 & 0 & -k_3 & k_3 & 0 \\ 0 & -k_4 & 0 & 0 & k_4 \end{bmatrix} \begin{Bmatrix} u_1 \\ u_2 \\ u_3 \\ u_4 \\ u_5 \end{Bmatrix} = \begin{Bmatrix} R_1 \\ 0 \\ 0 \\ R_4 \\ P \end{Bmatrix}$$

Step 4 Boundary condition and solution

We have $u_1 = u_4 = 0$

Therefore, the **reduced** global FEM equations are:

$$\begin{bmatrix} k_1 + k_2 + k_4 & -k_2 & -k_4 \\ -k_2 & k_2 + k_3 & 0 \\ -k_4 & 0 & k_4 \end{bmatrix} \begin{Bmatrix} u_2 \\ u_3 \\ u_5 \end{Bmatrix} = \begin{Bmatrix} 0 \\ 0 \\ P \end{Bmatrix}$$

The solution is

$$u_2 = \frac{k_2 + k_3}{(k_1 + k_2)(k_2 + k_3) - k_2^2} P ; u_3 = \frac{k_2}{(k_1 + k_2)(k_2 + k_3) - k_2^2} P ; u_5 = \left[\frac{k_2 + k_3}{(k_1 + k_2)(k_2 + k_3) - k_2^2} + \frac{1}{k_4} \right] P$$

Step 5 Post processing

Reaction force:

$$R_1 = -k_1 u_2 = -\frac{k_1(k_2 + k_3)}{(k_1 + k_2)(k_2 + k_3) - k_2^2} P ; R_4 = -k_3 u_3 = -\frac{k_2 k_3}{(k_1 + k_2)(k_2 + k_3) - k_2^2} P$$

[2] Step 1 Modeling

3 truss elements; 2-nodes / element; 2

DOF/ node

For the shown coordinate system:

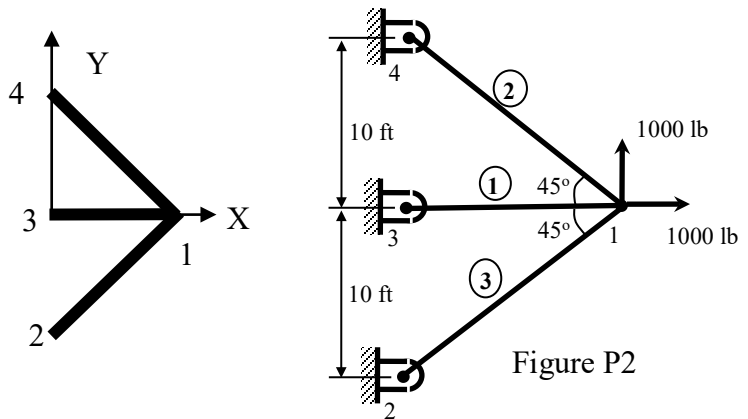

E	bar	α	$\cos\alpha$	$\sin\alpha$	$\cos^2\alpha$	$\sin^2\alpha$	$\cos\alpha\sin\alpha$
1	1-3	180°	-1	0	1	0	0
2	1-4	135°	$-1/\sqrt{2}$	$1/\sqrt{2}$	1/2	1/2	-1/2
3	1-2	225°	$-1/\sqrt{2}$	$-1/\sqrt{2}$	1/2	1/2	1/2

Step 2 Element equations

Here only stiffness matrices and unknowns vectors are provided.

$$[K]^{(1)} = \frac{30 \times 10^6 \times 2.5}{120} \begin{bmatrix} 1 & 0 & -1 & 0 \\ 0 & 0 & 0 & 0 \\ -1 & 0 & 1 & 0 \\ 0 & 0 & 0 & 0 \end{bmatrix} \quad \{u\}^{(1)} = \begin{Bmatrix} u_1 \\ v_1 \\ u_3 \\ v_3 \end{Bmatrix}$$

$$[K]^{(2)} = \frac{30 \times 10^6 \times 1.5}{120\sqrt{2}} \begin{bmatrix} 0.5 & -0.5 & -0.5 & 0.5 \\ -0.5 & 0.5 & 0.5 & -0.5 \\ -0.5 & 0.5 & 0.5 & -0.5 \\ 0.5 & -0.5 & -0.5 & 0.5 \end{bmatrix} \quad \{u\}^{(2)} = \begin{Bmatrix} u_1 \\ v_1 \\ u_4 \\ v_4 \end{Bmatrix}$$

$$\{P\} = \begin{Bmatrix} 1000 \\ 1000 \\ R_{2,x} \\ R_{2,y} \\ R_{3,x} \\ R_{3,y} \\ R_{4,x} \\ R_{4,y} \end{Bmatrix} = 2.5 \times 10^5 \begin{bmatrix} 3.56 & 0 & -0.53 & -0.53 & -2.5 & 0 & -0.53 & 0.53 \\ 0 & 1.06 & -0.53 & -0.53 & 0 & 0 & 0.53 & -0.53 \\ -0.53 & -0.53 & 0.53 & 0.53 & 0 & 0 & 0 & 0 \\ -0.53 & -0.53 & 0.53 & 0.53 & 0 & 0 & 0 & 0 \\ -2.5 & 0 & 0 & 0 & 2.5 & 0 & 0 & 0 \\ 0 & 0 & 0 & 0 & 0 & 0 & 0 & 0 \\ -0.53 & 0.53 & 0 & 0 & 0 & 0 & 0.53 & -0.53 \\ 0.53 & -0.53 & 0 & 0 & 0 & 0 & -0.53 & 0.53 \end{bmatrix} \begin{Bmatrix} 1.124 \times 10^{-3} \\ 3.774 \times 10^{-3} \\ 0 \\ 0 \\ 0 \\ 0 \\ 0 \\ 0 \end{Bmatrix}$$

$$= \{1000 \quad 1000 \quad -649 \quad -649 \quad -702 \quad 0 \quad 351 \quad -351\}^T$$

The forces are shown in the following figure.

$$\text{Stress in bar 1-3: } \sigma_{1-3} = \frac{702}{2.5} = 280.8 \text{ psi}$$

$$\text{Stress in bar 1-2: } \sigma_{1-2} = \frac{\sqrt{649^2 + 649^2}}{1.5} = 611.9 \text{ psi}$$

$$\text{Stress in bar 1-4: } \sigma_{1-4} = -\frac{\sqrt{351^2 + (-351)^2}}{1.5} = -331.1 \text{ psi}$$

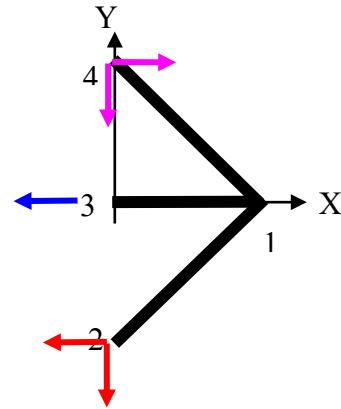

[3] Step 1 Modeling

3 truss elements; 2-nodes / element; 2 DOF/ node

$$L_1 = L_3 = 10 \text{ ft} = 120 \text{ in}, \quad L_2 = 10 \text{ ft} = 120\sqrt{2} \text{ in}$$

Step 2 Element equations

Element 1:(nodes 1-2)

The angle between the element's local coordinates and the global coordinates is $\theta = 90$.

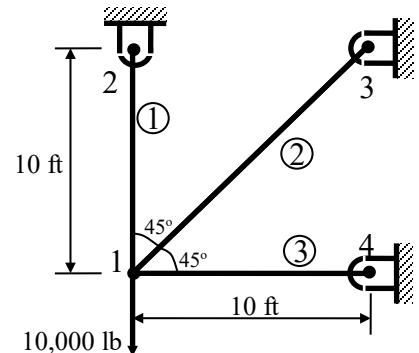

Figure P3

For a 2-D truss element, the global stiffness matrix is given by (where k_e = the element stiffness matrix, $C = \cos(\theta)$, and $S = \sin(\theta)$):

Therefore, the global stiffness matrix and the element characteristic equations are given by:

$$[K]^g = k_e \begin{bmatrix} C^2 & CS & -C^2 & -CS \\ CS & S^2 & -CS & -S^2 \\ -C^2 & -CS & C^2 & CS \\ -CS & -S^2 & CS & S^2 \end{bmatrix}$$

$$[K_1]^g = k_1 \begin{bmatrix} 0 & 0 & 0 & 0 \\ 0 & 1 & 0 & -1 \\ 0 & 0 & 0 & 0 \\ 0 & -1 & 0 & 1 \end{bmatrix}, \quad k_1 = \left(\frac{E_1 A_1}{L_1} \right); \quad \begin{Bmatrix} f_{1x}^1 \\ f_{1y}^1 \\ f_{2x}^1 \\ f_{2y}^1 \end{Bmatrix} = k_1 \begin{bmatrix} 0 & 0 & 0 & 0 \\ 0 & 1 & 0 & -1 \\ 0 & 0 & 0 & 0 \\ 0 & -1 & 0 & 1 \end{bmatrix} \begin{Bmatrix} u_1 \\ v_1 \\ u_2 \\ v_2 \end{Bmatrix}$$

For element # 2 (nodes 1-3)

The angle between the element's local coordinates and the global coordinates is $\theta = 45$.

The global stiffness matrix and the element characteristic equations are given by:

$$[K_2]^g = \frac{k_2}{2} \begin{bmatrix} 1 & 1 & -1 & -1 \\ -1 & 1 & -1 & -1 \\ -1 & -1 & 1 & 1 \\ -1 & -1 & 1 & 1 \end{bmatrix}, \quad k_2 = \left(\frac{E_2 A_2}{L_2} \right); \quad \begin{Bmatrix} f_{1x}^2 \\ f_{1y}^2 \\ f_{3x}^2 \\ f_{3y}^2 \end{Bmatrix} = \frac{k_2}{2} \begin{bmatrix} 1 & 1 & -1 & -1 \\ -1 & 1 & -1 & -1 \\ -1 & -1 & 1 & 1 \\ -1 & -1 & 1 & 1 \end{bmatrix} \begin{Bmatrix} u_1 \\ v_1 \\ u_3 \\ v_3 \end{Bmatrix}$$

For element # 3 (nodes 1-4)

The angle between the element's local coordinates and the global coordinates is $\theta = 0$.

The global stiffness matrix and the element characteristic equations are given by:

$$[K_3]^g = k_3 \begin{bmatrix} 1 & 0 & -1 & 0 \\ 0 & 0 & 0 & 0 \\ -1 & 0 & 1 & 0 \\ 0 & 0 & 0 & 0 \end{bmatrix}, \quad k_3 = \left(\frac{E_3 A_3}{L_3} \right); \quad \begin{Bmatrix} f_{1x}^3 \\ f_{1y}^3 \\ f_{4x}^3 \\ f_{4y}^3 \end{Bmatrix} = k_3 \begin{bmatrix} 1 & 0 & -1 & 0 \\ 0 & 0 & 0 & 0 \\ -1 & 0 & 1 & 0 \\ 0 & 0 & 0 & 0 \end{bmatrix} \begin{Bmatrix} u_1 \\ v_1 \\ u_4 \\ v_4 \end{Bmatrix}$$

Step 3 Assembly

The global matrix Assembly $[K]^G$

$$\begin{Bmatrix} f_{1x} \\ f_{1y} \\ f_{2x} \\ f_{2y} \\ f_{3x} \\ f_{3y} \\ f_{4x} \\ f_{4y} \end{Bmatrix} = \begin{bmatrix} \frac{k_2}{2} + k_3 & \frac{k_2}{2} & 0 & 0 & \frac{-k_2}{2} & \frac{-k_2}{2} & -k_3 & 0 \\ \frac{k_2}{2} & \frac{k_2}{2} + k_1 & 0 & -k_1 & \frac{-k_2}{2} & \frac{-k_2}{2} & 0 & 0 \\ 0 & 0 & 0 & 0 & 0 & 0 & 0 & 0 \\ 0 & -k_1 & 0 & k_1 & 0 & 0 & 0 & 0 \\ \frac{-k_2}{2} & \frac{-k_2}{2} & 0 & 0 & \frac{k_2}{2} & \frac{k_2}{2} & 0 & 0 \\ \frac{2}{2} & \frac{2}{2} & 0 & 0 & \frac{k_2}{2} & \frac{k_2}{2} & 0 & 0 \\ \frac{-k_2}{2} & \frac{-k_2}{2} & 0 & 0 & \frac{k_2}{2} & \frac{k_2}{2} & 0 & 0 \\ \frac{2}{2} & \frac{2}{2} & 0 & 0 & 0 & 0 & k_3 & 0 \\ 0 & 0 & 0 & 0 & 0 & 0 & 0 & 0 \end{bmatrix} \begin{Bmatrix} u_1 \\ v_1 \\ u_2 \\ v_2 \\ u_3 \\ v_3 \\ u_4 \\ v_4 \end{Bmatrix}$$

Where:

$$k_1 = k_3 = \frac{30 \times 10^6 \times 2}{120} = 5 \times 10^5 \text{ Ib/in} \quad k_2 = \frac{30 \times 10^6 \times 2}{120\sqrt{2}} = \frac{5 \times 10^5}{\sqrt{2}} \text{ Ib/in}$$

Step 4 Boundary Conditions and Solution

From the geometry model, the boundary conditions are:

$$u_2 = v_2 = u_3 = v_3 = u_4 = v_4 = 0.0$$

$$f_{1x} = 0.0, \quad \text{and} \quad f_{1y} = -10,000 \text{ Ib}$$

$$\begin{Bmatrix} 0.0 \\ -10,000 \\ f_{2x} \\ f_{2y} \\ f_{3x} \\ f_{3y} \\ f_{4x} \\ f_{4y} \end{Bmatrix} = \begin{bmatrix} \frac{k_2}{2} + k_3 & \frac{k_2}{2} & 0 & 0 & \frac{-k_2}{2} & \frac{-k_2}{2} & -k_3 & 0 \\ \frac{k_2}{2} & \frac{k_2}{2} + k_1 & 0 & -k_1 & \frac{-k_2}{2} & \frac{-k_2}{2} & 0 & 0 \\ 0 & 0 & 0 & 0 & 0 & 0 & 0 & 0 \\ 0 & -k_1 & 0 & k_1 & 0 & 0 & 0 & 0 \\ \frac{-k_2}{2} & \frac{-k_2}{2} & 0 & 0 & \frac{k_2}{2} & \frac{k_2}{2} & 0 & 0 \\ \frac{2}{2} & \frac{2}{2} & 0 & 0 & \frac{2}{2} & \frac{2}{2} & 0 & 0 \\ \frac{-k_2}{2} & \frac{-k_2}{2} & 0 & 0 & \frac{k_2}{2} & \frac{k_2}{2} & 0 & 0 \\ \frac{2}{2} & \frac{2}{2} & 0 & 0 & \frac{2}{2} & \frac{2}{2} & 0 & 0 \\ -k_3 & 0 & 0 & 0 & 0 & 0 & k_3 & 0 \\ 0 & 0 & 0 & 0 & 0 & 0 & 0 & 0 \end{bmatrix} \begin{Bmatrix} u_1 \\ v_1 \\ 0 \\ 0 \\ 0 \\ 0 \\ 0 \\ 0 \end{Bmatrix}$$

By eliminating the corresponding rows and columns in the global characteristic equation, one gets:

$$\begin{Bmatrix} 0.0 \\ -10,000 \end{Bmatrix} = \begin{bmatrix} \frac{k_2}{2} + k_3 & \frac{k_2}{2} \\ \frac{k_2}{2} & \frac{k_2}{2} + k_1 \end{bmatrix} \begin{Bmatrix} u_1 \\ v_1 \end{Bmatrix} \quad \text{or} \quad \begin{Bmatrix} 0.0 \\ -10,000 \end{Bmatrix} = 5 \times 10^5 \begin{bmatrix} \frac{1}{2\sqrt{2}} + 1 & \frac{1}{2\sqrt{2}} \\ \frac{1}{2\sqrt{2}} & \frac{1}{2\sqrt{2}} + 1 \end{bmatrix} \begin{Bmatrix} u_1 \\ v_1 \end{Bmatrix}$$

gives $u_1 = 4.142 \times 10^{-3}$ in and $v_1 = -0.01586$ in

Step 5 Post processing

To get the forces at nodes 2,3 and 4

$$\begin{Bmatrix} 0.0 \\ -10,000 \\ f_{2x} \\ f_{2y} \\ f_{3x} \\ f_{3y} \\ f_{4x} \\ f_{4y} \end{Bmatrix} = \begin{bmatrix} \frac{k_2}{2} + k_3 & \frac{k_2}{2} & 0 & 0 & \frac{-k_2}{2} & \frac{-k_2}{2} & -k_3 & 0 \\ \frac{k_2}{2} & \frac{k_2}{2} + k_1 & 0 & -k_1 & \frac{-k_2}{2} & \frac{-k_2}{2} & 0 & 0 \\ 0 & 0 & 0 & 0 & 0 & 0 & 0 & 0 \\ 0 & -k_1 & 0 & k_1 & 0 & 0 & 0 & 0 \\ \frac{-k_2}{2} & \frac{-k_2}{2} & 0 & 0 & \frac{k_2}{2} & \frac{k_2}{2} & 0 & 0 \\ \frac{2}{2} & \frac{2}{2} & 0 & 0 & \frac{2}{2} & \frac{2}{2} & 0 & 0 \\ \frac{-k_2}{2} & \frac{-k_2}{2} & 0 & 0 & \frac{k_2}{2} & \frac{k_2}{2} & 0 & 0 \\ \frac{2}{2} & \frac{2}{2} & 0 & 0 & \frac{2}{2} & \frac{2}{2} & 0 & 0 \\ -k_3 & 0 & 0 & 0 & 0 & 0 & k_3 & 0 \\ 0 & 0 & 0 & 0 & 0 & 0 & 0 & 0 \end{bmatrix} \begin{Bmatrix} 4.142 \times 10^{-3} \\ -0.01586 \\ 0 \\ 0 \\ 0 \\ 0 \\ 0 \\ 0 \end{Bmatrix}$$

$$\begin{Bmatrix} f_{2x} \\ f_{2y} \\ f_{3x} \\ f_{3y} \\ f_{4x} \\ f_{4y} \end{Bmatrix} = \begin{bmatrix} 0 & 0 & \frac{-k_2}{2} & \frac{-k_2}{2} & -k_3 & 0 \\ 0 & -k_1 & \frac{-k_2}{2} & \frac{-k_2}{2} & 0 & 0 \end{bmatrix}^T \begin{Bmatrix} u_1 \\ v_1 \end{Bmatrix}$$

$$f_{2x} = 0.0$$

$$f_{2y} = -k_1 v_1 = -5 \times 10^5 x (-0.01586) = 7929 \text{ lb}$$

$$f_{3x} = \frac{-k_2}{2} (u_1 + v_1) = \frac{-5 \times 10^5}{2\sqrt{2}} (4.142 \times 10^{-3} - 0.01586) = 2071 \text{ lb}$$

$$f_{3y} = \frac{-k_2}{2} (u_1 + v_1) = \frac{-5 \times 10^5}{2\sqrt{2}} (4.142 \times 10^{-3} - 0.01586) = 2071 \text{ lb}$$

$$f_{4x} = -k_3 u_1 = -5 \times 10^5 x (4.142 \times 10^{-3}) = -2071 \text{ lb}$$

$$f_{4y} = 0.0$$

Stresses at each bar

Since the structure in hand is a truss structure, the stresses are axial stresses (tension or compression)

Stresses at bar #1

$$\sigma_1 = \frac{F_1}{A_1} = \frac{\sqrt{f_{2x}^2 + f_{2y}^2}}{A_1} = \frac{\sqrt{0 + 7929^2}}{2} = 3964.5 \text{ psi, Tension}$$

Stresses at bar #2

$$\sigma_2 = \frac{F_2}{A_2} = \frac{\sqrt{f_{3x}^2 + f_{3y}^2}}{A_2} = \frac{\sqrt{2071^2 + 2071^2}}{2} = 1464.4 \text{ psi, Tension}$$

Stresses at bar #3

$$\sigma_3 = \frac{F_3}{A_3} = \frac{-2071}{2} = -1035.5 \text{ psi, Compression}$$

[4] The model has 7-2D truss elements, with 2-DOF/node as shown.

Element 1

$$\begin{bmatrix} K_1 & 0 & -K_1 & 0 \\ 0 & 0 & 0 & 0 \\ -K_1 & 0 & K_1 & 0 \\ 0 & 0 & 0 & 0 \end{bmatrix} \begin{Bmatrix} u_1 \\ v_1 \\ u_2 \\ v_2 \end{Bmatrix} = \begin{Bmatrix} F_{1x}^1 \\ F_{1y}^1 \\ F_{2x}^1 \\ F_{2y}^1 \end{Bmatrix}$$

$$\text{where } K_1 = \frac{E_1 A_1}{L_1}$$

Element 2

$$\begin{bmatrix} 0 & 0 & 0 & 0 \\ 0 & K_2 & 0 & -K_2 \\ 0 & 0 & 0 & 0 \\ 0 & -K_2 & 0 & K_2 \end{bmatrix} \begin{Bmatrix} u_1 \\ v_1 \\ u_4 \\ v_4 \end{Bmatrix} = \begin{Bmatrix} F_{1x}^2 \\ F_{1y}^2 \\ F_{4x}^2 \\ F_{4y}^2 \end{Bmatrix}$$

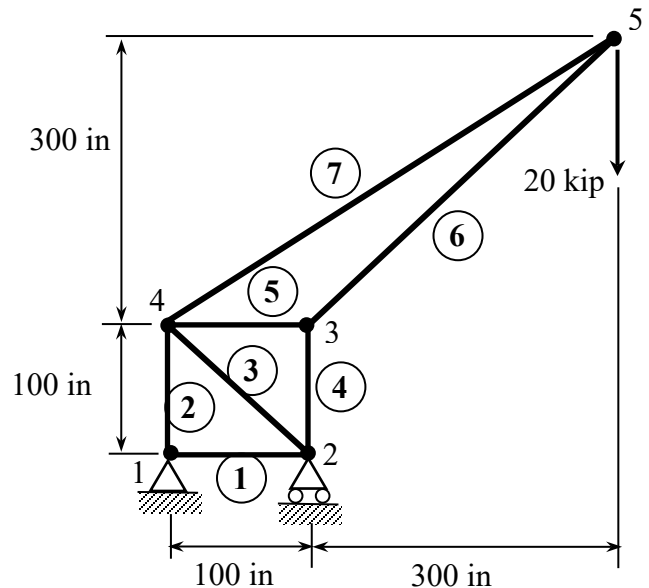

where $K_2 = \frac{E_2 A_2}{L_2}$

Element 3

$\alpha = 135^\circ$; $\cos 135^\circ = -0.7071$, $\sin 135^\circ = 0.7071$, $\cos^2 135^\circ = 0.5$, $\sin^2 135^\circ = 0.5$

$$\begin{bmatrix} 0.5K_3 & -0.5K_3 & -0.5K_3 & 0.5K_3 \\ -0.5K_3 & 0.5K_3 & 0.5K_3 & -0.5K_3 \\ -0.5K_3 & 0.5K_3 & 0.5K_3 & -0.5K_3 \\ 0.5K_3 & -0.5K_3 & -0.5K_3 & 0.5K_3 \end{bmatrix} \begin{Bmatrix} u_2 \\ v_2 \\ u_4 \\ v_4 \end{Bmatrix} = \begin{Bmatrix} F_{2x}^3 \\ F_{2y}^3 \\ F_{4x}^3 \\ F_{4y}^3 \end{Bmatrix} \quad \text{where } K_3 = \frac{E_3 A_3}{L_3}$$

Element 4

$$\begin{bmatrix} 0 & 0 & 0 & 0 \\ 0 & K_4 & 0 & -K_4 \\ 0 & 0 & 0 & 0 \\ 0 & -K_4 & 0 & K_4 \end{bmatrix} \begin{Bmatrix} u_2 \\ v_2 \\ u_3 \\ v_3 \end{Bmatrix} = \begin{Bmatrix} F_{2x}^4 \\ F_{2y}^4 \\ F_{3x}^4 \\ F_{3y}^4 \end{Bmatrix}$$

where $K_4 = \frac{E_4 A_4}{L_4}$

Element 5

$$\begin{bmatrix} K_5 & 0 & -K_5 & 0 \\ 0 & 0 & 0 & 0 \\ -K_5 & 0 & K_5 & 0 \\ 0 & 0 & 0 & 0 \end{bmatrix} \begin{Bmatrix} u_3 \\ v_3 \\ u_4 \\ v_4 \end{Bmatrix} = \begin{Bmatrix} F_{3x}^5 \\ F_{3y}^5 \\ F_{4x}^5 \\ F_{4y}^5 \end{Bmatrix}$$

where $K_5 = \frac{E_5 A_5}{L_5}$

Element 6

$\alpha = 45^\circ$; $\cos 45^\circ = 0.7071$, $\sin 45^\circ = 0.7071$, $\cos^2 45^\circ = 0.5$, $\sin^2 45^\circ = 0.5$

$$\begin{bmatrix} 0.5K_6 & 0.5K_6 & -0.5K_6 & -0.5K_6 \\ 0.5K_6 & 0.5K_6 & -0.5K_6 & -0.5K_6 \\ -0.5K_6 & -0.5K_6 & 0.5K_6 & 0.5K_6 \\ -0.5K_6 & -0.5K_6 & 0.5K_6 & 0.5K_6 \end{bmatrix} \begin{Bmatrix} u_3 \\ v_3 \\ u_5 \\ v_5 \end{Bmatrix} = \begin{Bmatrix} F_{3x}^6 \\ F_{3y}^6 \\ F_{5x}^6 \\ F_{5y}^6 \end{Bmatrix} \quad \text{where } K_6 = \frac{E_6 A_6}{L_6}$$

Element 7

$\theta = \text{atan}\left(\frac{3}{4}\right) = 36.9^\circ$; $\cos \theta = 0.8$, $\sin \theta = 0.6$, $\cos^2 \theta = 0.64$, $\sin^2 \theta = 0.36$

$$\begin{bmatrix} 0.64K_6 & 0.48K_6 & -0.64K_6 & -0.48K_6 \\ 0.48K_6 & 0.36K_6 & -0.48K_6 & -0.36K_6 \\ -0.64K_6 & -0.48K_6 & 0.64K_6 & 0.48K_6 \\ -0.48K_6 & -0.36K_6 & 0.48K_6 & 0.36K_6 \end{bmatrix} \begin{Bmatrix} u_4 \\ v_4 \\ u_5 \\ v_5 \end{Bmatrix} = \begin{Bmatrix} F_{4x}^7 \\ F_{4y}^7 \\ F_{5x}^7 \\ F_{5y}^7 \end{Bmatrix} \quad \text{where } K_7 = \frac{E_7 A_7}{L_7}$$

Assembly of Global Equation

$[K]\{U\} = \{F\}$ where

$$K = \begin{bmatrix} k & 0 & -k & 0 & 0 & 0 & 0 & 0 & 0 & 0 & 0 \\ 0 & k & 0 & 0 & 0 & 0 & 0 & 0 & -k & 0 & 0 \\ -k & 0 & k+0.5K_3 & -0.5K_3 & 0 & 0 & -0.5K_3 & 0.5K_3 & 0 & 0 & 0 \\ 0 & 0 & -0.5K_3 & k+0.5K_3 & 0 & -k & 0.5K_3 & -0.5K_3 & 0 & 0 & 0 \\ 0 & 0 & 0 & 0 & k+0.5K_6 & 0.5K_6 & -k & 0 & 0 & 0.5K_6 & -0.5K_6 \\ 0 & 0 & 0 & -k & 0.5K_6 & 0 & 0 & 0 & 0 & 0.5K_6 & -0.5K_6 \\ 0 & -k & -0.5K_3 & 0.5k_3 & -k & 0 & k+0.5K_3+0.64K_7 & -0.5K_3+0.48K_7 & -0.64K_7 & -0.48K_7 & -0.48K_7 \\ 0 & -k & 0.5K_3 & -0.5k_3 & 0 & 0 & -0.5K_3+0.48K_7 & 0.5K_3+k+0.36K_7 & -0.48K_7 & -0.48K_7 & -0.36K_7 \\ 0 & 0 & 0 & 0 & -0.5K_6 & -0.5K_6 & -0.64K_7 & -0.48K_7 & 0.5K_6+0.64K_7 & 0.5K_6+0.48K_7 & 0.5K_6+0.48K_7 \\ 0 & 0 & 0 & 0 & -0.5K_6 & -0.5K_6 & -0.48K_7 & -0.36K_7 & 0.5K_6+0.48K_7 & 0.5K_6+0.36K_7 & 0.5K_6+0.36K_7 \end{bmatrix}$$

$$k = K_1 = K_2 = K_4 = K_5$$

$$\{U\} = \{U_1 \quad V_1 \quad U_2 \quad V_2 \quad U_3 \quad V_3 \quad U_4 \quad V_4 \quad U_5 \quad V_5\}^T$$

$$\{F\} = \{F_{1x} \quad F_{1y} \quad F_{2x} \quad F_{2y} \quad F_{3x} \quad F_{3y} \quad F_{4x} \quad F_{4y} \quad F_{5x} \quad F_{5y}\}^T$$

Boundary Conditions

$U_1 = V_1 = V_2 = 0$, therefore we can eliminate 1st, 2nd, 4th rows and columns from the unreduced global stiffness matrix above, we get:

$$\begin{bmatrix} k+0.5K_3 & 0 & 0 & -0.5K_6 & 0.5K_6 & 0 & 0 \\ 0 & k+0.5K_6 & 0.5K_6 & -k & 0 & -0.5K_6 & -0.5K_6 \\ 0 & 0.5K_6 & k+0.5K_6 & 0 & 0 & -0.5K_6 & -0.5K_6 \\ -0.5K_3 & -k & 0 & k+0.5K_3+0.64K_7 & -0.5K_6+0.36K_7 & -0.64K_7 & -0.48K_7 \\ 0.5K_3 & 0 & 0 & -0.5K_3+0.48K_7 & k+0.5K_3+0.36K_7 & -0.48K_7 & -0.36K_7 \\ 0 & -0.5K_6 & -0.5K_6 & -0.64K_7 & -0.48K_7 & 0.5K_6+0.64K_7 & 0.5K_6+0.48K_7 \\ 0 & -0.5K_6 & 0.5K_6 & -0.48K_7 & -0.36K_7 & 0.5K_6+0.48K_7 & 0.5K_6+0.36K_7 \end{bmatrix}$$

$$\{U\} = \{U_2 \quad U_3 \quad V_3 \quad U_4 \quad V_4 \quad U_5 \quad V_5\}^T$$

$$\{F\} = \{0 \quad 0 \quad 0 \quad 0 \quad 0 \quad 0 \quad -20000\}^T$$

Using:

$$\begin{aligned} E &= 30e6 \text{ psi}, & L_1 = L_2 = L_4 = L_5 &= 100 \text{ in}, & L_3 &= 141.42 \text{ in} \\ L_6 &= 424.264 \text{ in}, & L_7 &= 500 \text{ in}, & \text{Area, } A &= 1 \text{ in}^2 \end{aligned}$$

We get:

$$\begin{aligned} k = K_1 = K_2 = K_4 = K_5 &= 300e3 \text{ lb/in}, & K_3 &= 212.132 \text{ e3 lb/in} \\ K_6 &= 70.7107 \text{ e3 lb/in}, & K_7 &= 60 \text{ e3 lb/in} \end{aligned}$$

By substituting the K values back into the reduced global matrix and solving for unknowns, we get:

Node #	2		3		4		5	
	<i>X disp.</i>	<i>Y disp.</i>	<i>X disp.</i>	<i>Y disp.</i>	<i>X disp.</i>	<i>Y disp.</i>	<i>X disp.</i>	<i>Y disp.</i>
	0.00	0.00	-0.667	-0.2667	0.2	0.2	17.5215	-20.1176

And substituting these values back into unreduced global matrix, we get reactions at nodes 1 & 2:

$$F_{1x} = 0, \quad F_{1y} = -60000 \text{ lb}, \quad F_{2y} = 80000 \text{ lb}$$

Hand calculation Checks using Mechanics of Materials:

External support forces

$$\sum M_1 = 0: \quad (20000)(400) - F_{2y}(100) = 0 \quad \text{gives: } F_{2y} = 80000 \text{ lbs}$$

$$\sum F_y = 0: \quad F_{1y} + 80000 = 20000 \quad \text{gives: } F_{1y} = -60000 \text{ lbs}$$

$$\sum F_x = 0: \quad F_{1x} = 0$$

Internal Members' Forces

Using the method of joints:

At Joint 1

$$\sum F_x = 0 \Rightarrow F_1 = 0, \quad \sum F_y = 0 \Rightarrow F_2 = 60000 \text{ lbs (tension)}$$

At Joint 2

$$\sum F_x = 0 \Rightarrow F_3 = 0, \quad \sum F_y = 0 \Rightarrow F_4 = 80000 \text{ lbs (compression)}$$

At Joint 3

$$\sum F_y = 0 \Rightarrow F_6 \left(\frac{1}{\sqrt{2}}\right) = 80000 \quad F_6 = 113137.1 \text{ lbs (compression)}$$

$$\sum F_x = 0 \Rightarrow F_5 = F_6 \left(\frac{1}{\sqrt{2}}\right) = 80000 \text{ lbs (compression)}$$

At Joint 4

$$\sum F_x = 0 \Rightarrow F_7 \left(\frac{4}{5}\right) - 80000 = 0 \quad F_7 = 100000 \text{ lbs (tension)}$$

To Check Buckling

Critical Load is:
$$P_{CR} = \frac{\pi^2 EI}{L^2}$$

Member	L (in)	Compression Force (lb)	P _{CR} (lb)
4	100	80,000	29,609 I
5	100	80,000	29,609 I
6	424.26	113,137.	1645 I

Depending on the value of I, the criticality of buckling may be determined from the above table.

ANSYS/Workbench Solution Synopsis

