

Chapter 1 Machine Tools and Machining Operations

1. Power available, $P_m = P_e \eta_m = 2000 \times 0.5 = 1000W$

Also $P_m = p_s Z_w$ and therefore $Z_w = P_m / p_s = \frac{1000}{2.73 \times 10^9} = 3.66 \times 10^{-7} \text{ m}^3/\text{s}$

For finish cut

$$Z_w = a_p f v$$

$$a_p = \frac{Z_w}{f v} = \frac{3.66 \times 10^{-7}}{0.13 \times 10^{-3} \times 1.5} \approx 2 \text{ mm}$$

$$t_{mf} = \frac{l_w}{f} \times \frac{\pi}{1.5} (69 \times 10^{-3}) = 167 \text{ s}$$

Volume V to be removed in rough cut:

$$V = \frac{\pi}{4} \left[\left(\frac{80}{1000} \right)^2 - \left(\frac{69}{1000} \right)^2 \right] \times \frac{150}{1000} = 195 \times 10^{-6} \text{ m}^3$$

$$t_{mr} = \frac{V}{Z_w} = \frac{195 \times 10^{-6}}{3.66 \times 10^{-7}} = 532 \text{ s}$$

$$t_m = t_{mf} + t_{mr} = 167 + 532 = 699 \text{ s}$$

Total production time = $2000(120 + 2 \times 15 + 699) = 1698 \text{ ks}$

Alternatively:

Total volume removed = $256 \times 10^{-6} \text{ m}^3$

$$Z_w = 3.66 \times 10^{-7} \text{ m}^3/\text{s}$$

Therefore $t_m = \frac{\text{vol}}{Z_w} = 699 \text{ s}$

2. (a) Rough cut:

$$P_m = 0.7 \times 3000 = 2100 \text{ w}$$

$$Z_w = \frac{P_m}{p_s} = \frac{2100}{2.3 \times 10^9} = 0.91 \times 10^{-6} \text{ m}^3/\text{s}$$

$$\text{Volume to be removed} = \frac{50}{10^3} \times \frac{\pi}{4} \left[\left(\frac{100}{10^3} \right)^2 - \left(\frac{76}{10^3} \right)^2 \right] = 0.17 \times 10^{-3} \text{ m}^3$$

$$t_{mr} = \frac{0.17}{0.91} \times \frac{10^6}{10^3} = 0.19 \text{ ks} = 190 \text{ s}$$

(b) Finish cut:

$$f = 0.1 \text{ mm}, a_p = 3 \text{ mm}, v = 1.5 \text{ m/s}$$

$$t_{mf} = \frac{50\pi}{0.1} \times \frac{73}{10^3} \times \frac{1}{1.5} = 76.5 \text{ s}$$

$$(c) t_{pr} = 20 + 2 \times 30 + 190 + 76.5 = 347 \text{ s}$$

3.

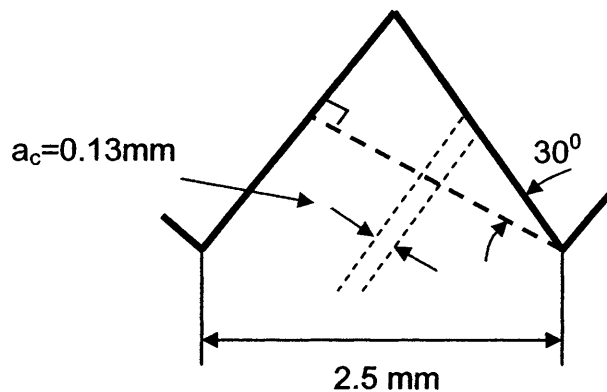

$$(a) \text{ Total tool feed normal to cutting edge} = 2.5 \cos 30^\circ = 2.165 \text{ mm}$$

$$\text{Number of passes} = 2.165 / 0.13 \approx 17$$

$$(b) \text{ Production time} = 17 \left(\frac{250}{2.5 \times 0.8} + 20 \right) = 2.465 \text{ s}$$

4.

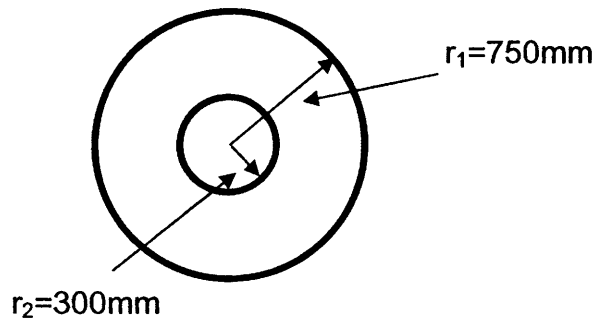

(a) Radial distance moved by tool = $750 - 300 = 450$ mm

Therefore number of revolutions of workpiece = $450 / 0.25$

$$t_m = 450 / (0.25 \times 0.5) = 3600 \text{ s}$$

(b) $P_m = p_s Z_w = 3.5 \times 10^9 Z_w$ W

$$P_{m1} = 3.5 \times 10^9 Z_w = 3.5 \times 10^9 f a_p n_w 2\pi r_1$$

$$= 3.5 \times 10^9 \times 0.25 \times 10^{-3} \times 6 \times 10^{-3} \times 0.5 \times 1.5\pi = 12.37 \text{ kW}$$

(c) $P_{m2} = 3.5 \times 10^9 \times 0.25 \times 10^{-3} \times 6 \times 10^{-3} \times 0.5 \times 0.6\pi = 4.95 \text{ kW}$

5.

a) $v = \pi d_0 n = \pi \times 0.5 \times 6 = 9.42$ m/s

$$A_c = f a_p = 0.25 \times 12 \times 10^{-6} = 3 \times 10^{-6} \text{ m}^2$$

$$Z_w = v A_c = 9.42 \times 3 \times 10^{-6} = 28.27 \times 10^{-6} \text{ m}^3/\text{s}$$

$$P_m = p_s Z_w = 2.6 \times 10^9 \times 28.27 \times 10^{-6} = 73.51 \text{ kW}$$

b) $p_s = F_c / A_c$ or $F_c = A_c p_s$

$$F_c = 3 \times 10^{-6} \times 2.6 \times 10^9 = 7.8 \text{ kN}$$

c) $t_m = \frac{125}{0.25} \times \frac{1}{6} = 83.33$ s

6.

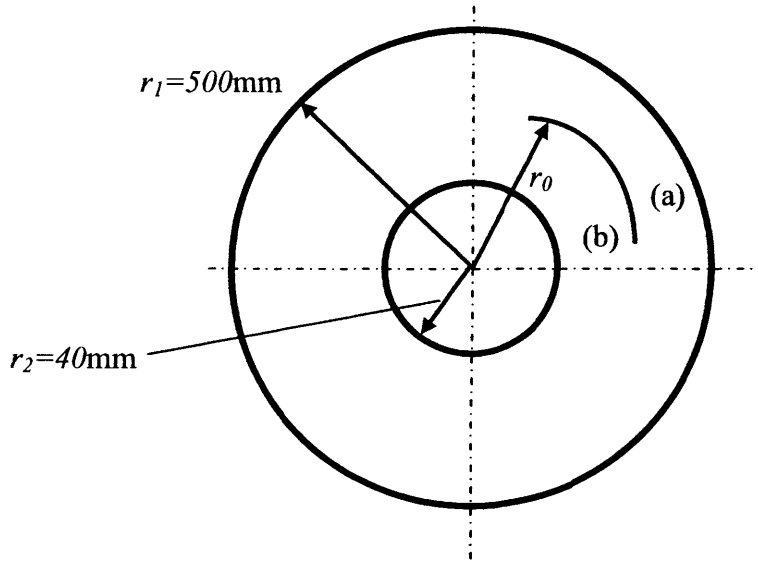

Region (a) maximum power: $P_m = p_s Z_w$

$$Z_w = \frac{3000}{2.27 \times 10^9} \text{ m/s} \quad (1)$$

When the rotational frequency rises to critical value:

$$Z_w = f a_p n_w \times 2\pi r_0 \quad (2)$$

Combining (1) and (2)

$$r_0 = \frac{3000}{2.27 \times 10^9 \times 9 \times 10^{-3} \times 0.25 \times 10^{-3} \times 0.7 \times 2\pi} = 0.24 \text{ m}$$

V , volume removed in period (a):

$$V = \frac{\pi}{4} (1^2 - 0.48^2) \times 5 \times 10^{-3}$$

Machining time in period (a):

$$t_{ma} = \frac{V}{Z_w} = \frac{\frac{\pi}{4} (1^2 - 0.48^2) \times 5 \times 10^{-3}}{(3000 / 2.27 \times 10^9)} = 2.285 \text{ ks}$$

Machining time in period (b):

$$t_{mb} = \frac{r_0 - r_2}{f n_w} = \frac{200.4}{0.25 \times 0.7} = 1.145 \text{ ks}$$

$$t_m = t_{ma} + t_{mb} + 600 = 4.03 \text{ ks}$$

For 50 components $t_{pr} = 50 \times 4.03 = 201.5 \text{ ks}$