

### P1.1-1: Viscosity of a dilute gas

Momentum transfer occurs in a fluid due to interactions between molecules that results in a transfer of momentum. This process is characterized by viscosity, which relates the shear stress to a velocity gradient in the same way Fourier's Law relates heat flux to a temperature gradient. It is not surprising, then, that the viscosity and thermal conductivity of an ideal gas are analogous transport properties.

a.) Using reasoning similar to that provided in Section 1.1.2 for thermal conductivity, show that the viscosity of an ideal gas can be estimated according to  $\mu \propto \sqrt{T MW} / \sigma^2$ .

Consider momentum transfer through a fluid in which a velocity gradient has been established in the  $x$ -direction, as shown in Figure 1. We can evaluate the net rate of momentum transferred through a plane that is located at position  $x$ . The flux of molecules passing through the plane from left-to-right (i.e., in the positive  $x$ -direction) is proportional to the number density of the molecules ( $n_{ms}$ ) and their mean velocity ( $v_{ms}$ ). The molecules that are moving in the positive  $x$ -direction experienced their last interaction at  $x-L_{ms}$  (on average), where  $L_{ms}$  is the distance between molecular interactions. The rate of momentum associated with these molecules per unit area is the product of the rate of molecules passing through the plane ( $n_{ms} v_{ms}$ ) momentum and the momentum per molecule; the momentum per molecule is the product of the mass of the molecule ( $M$ ) and its  $x$ -velocity at the point where it experienced its last collision,  $x-L_{ms}$  ( $M u_{x-L_{ms}}$ ). Therefore, the rate of momentum passing through the plane from left-to-right ( $\dot{M}''_{x+}$ ) is given approximately by:

$$\dot{M}''_{x+} \approx n_{ms} v_{ms} M u_{ms,x-L_{ms}} \quad (1)$$

Similarly, the momentum per unit area passing through the plane from right-to-left ( $\dot{M}''_{x-}$ ) is given by:

$$\dot{M}''_{x-} \approx n_{ms} v_{ms} M u_{x+L_{ms}} \quad (2)$$

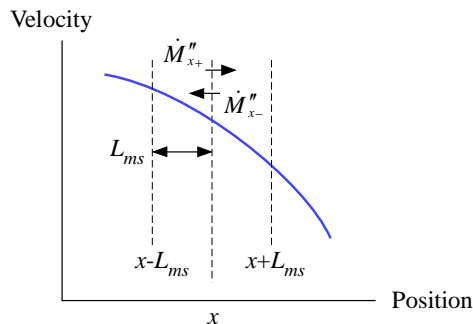

**Figure 1: Momentum flows through a plane in a material.**

The net rate of momentum flux passing through the plane per unit area in the positive  $x$ -direction ( $\dot{M}''$ ) is the difference between  $\dot{M}''_{x+}$  and  $\dot{M}''_{x-}$ ,

$$\dot{M}'' \approx n_{ms} v_{ms} M (u_{x-L_{ms}} - u_{x+L_{ms}}) \quad (3)$$

which can be rearranged to yield:

$$\dot{M}'' \approx -2 n_{ms} v_{ms} M L_{ms} \underbrace{\frac{(u_{x+L_{ms}} - u_{x-L_{ms}})}{L_{ms}}}_{\frac{\partial u}{\partial x}} \approx - \underbrace{2 n_{ms} v_{ms} M L_{ms}}_{\propto \mu} \frac{\partial u}{\partial x} \quad (4)$$

Comparing Eq. (4) with the definition of viscosity shows that the viscosity is proportional to the product of the number of molecules per unit volume, their average velocity, the mass of each molecule, and the mean distance between their interactions.

$$\mu \propto n_{ms} v_{ms} M L_{ms} \quad (5)$$

The mass of a molecule is the molecular weight,  $MW$ . As noted in Eq. (1-14), kinetic theory indicates that

$$v_{ms} \propto \sqrt{\frac{R_{univ} T}{MW}} \quad (6)$$

where  $R_{univ}$  is the universal gas constant and  $T$  is the absolute temperature. The distance between molecular interactions was derived in Eq. (1-17) is

$$L_{ms} = \frac{1}{n_{ms} \pi \sigma^2} \quad (7)$$

where  $\sigma$  is the equivalent radius of the molecule. Substituting Eqs. (6) and (7) into Eq. (5) shows that:

$$\boxed{\mu \propto \frac{1}{\sigma^2} \sqrt{T MW}} \quad (8)$$

which is identical to Eq. (1-18) for conductivity if the specific heat capacity is removed.

### P1.1-2 (1-1 in text): Conductivity of a dilute gas

Section 1.1.2 provides an approximation for the thermal conductivity of a monatomic gas at ideal gas conditions. Test the validity of this approximation by comparing the conductivity estimated using Eq. (1-18) to the value of thermal conductivity for a monatomic ideal gas (e.g., low pressure argon) provided by the internal function in EES. Note that the molecular radius,  $\sigma$ , is provided in EES by the Lennard-Jones potential using the function `sigma_LJ`.

a.) What is the value and units of the proportionality constant required to make Eq. (1-18) an equality?

Equation (1-18) is repeated below:

$$k \propto \frac{c_v}{\sigma^2} \sqrt{\frac{T}{MW}} \quad (1)$$

Equation (1) is written as an equality by including a constant of proportionality ( $C_k$ ):

$$k = C_k \frac{c_v}{\sigma^2} \sqrt{\frac{T}{MW}} \quad (2)$$

Solving for  $C_k$  leads to:

$$C_k = \frac{k \sigma^2}{c_v} \sqrt{\frac{MW}{T}} \quad (3)$$

which indicates that  $C_k$  has units  $\text{m}\cdot\text{kg}^{1.5}/\text{s}\cdot\text{kgmol}^{0.5}\cdot\text{K}^{0.5}$ .

The inputs are entered in EES for Argon at relatively low pressure (0.1 MPa) and 300 K.

```
"Problem 1.1-2"
$UnitSystem SI MASS RAD PA K J
$TABSTOPS 0.2 0.4 0.6 0.8 3.5 in

T=300 [K]                                "temperature"
F$='Argon'                                "fluid"
P_MPa=0.1 [MPa]                           "pressure, in MPa"
P=P_MPa*convert(MPa, Pa)                  "pressure"
```

The conductivity, specific heat capacity, Lennard-Jones potential, and molecular weight of Argon ( $k$ ,  $c_v$ ,  $\sigma$ , and  $MW$ ) are evaluated using EES' built-in functions. Equation (3) is used to evaluate the proportionality constant.

```
k=conductivity(F$,T=T,P=P)                "conductivity"
cv=cv(F$,T=T,P=P)                         "specific heat capacity at constant volume"
MW=molarMass(F$)                          "molecular weight"
sigma=sigma_LJ(F$)                         "Lennard-Jones potential"
C_k=k*sigma^2*sqrt(MW/T)/cv                "constant of proportionality"
```

which leads to  $C_k = 2.619 \times 10^{-24} \text{ m}\cdot\text{kg}^{1.5}/\text{s}\cdot\text{kgmol}^{0.5}\cdot\text{K}^{0.5}$ .

- b.) Plot the value of the proportionality constant for 300 K argon at pressures between 0.01 and 100 MPa on a semi-log plot with pressure on the log scale. At what pressure does the approximation given in Eq. (1-18) begin to fail at 300 K for argon?

Figure 1 illustrates the constant of proportionality as a function of pressure for argon at 300 K. The approximation provided by Eq. (1-18) breaks down at approximately 1 MPa.

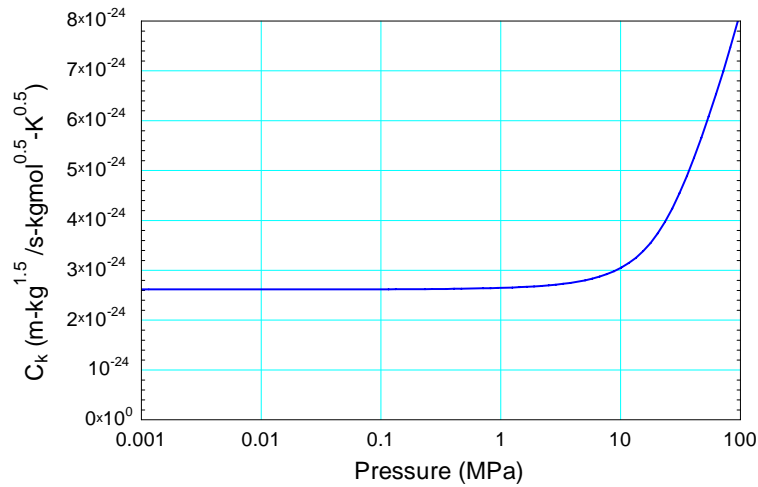

**Figure 1: Constant of proportionality in Eq. (3) as a function of pressure for argon at 300 K.**

### P1.1-3: Conductivity of a polyatomic gas

Equation (1-18) cannot be used to understand the thermal conductivity of a polyatomic ideal gas, such as low pressure oxygen, because the ideal gas thermal conductivity is the sum of two terms corresponding to translational and internal contributions.

$$k = k_{trans} + k_{int} \quad (1)$$

Equation (1-18) only considers the translational contribution. Because thermal conductivity and viscosity are analogous transport properties, the translation term for the thermal conductivity of a dilute gas can be estimated as a function of the viscosity ( $\mu$ ) of the gas according to:

$$k_{trans} = \frac{15R_{univ} \mu}{4MW} \quad (2)$$

where  $R_{univ}$  is the universal gas constant and  $MW$  is the molar mass of the gas. The internal contribution for a polyatomic molecule results from the transfer of energy associated with rotational and vibrational degrees of freedom. An estimate of the internal contribution is provided by the Eucken<sup>1</sup> correlation

$$k_{int} \approx \frac{\mu}{MW} \left[ c_p - \frac{5R_{univ}}{2} \right] \quad (3)$$

where the viscosity is in units of Pa-s and the constant pressure specific heat and gas constant are in units of J/kmol-K. The internal contribution is zero for a monatomic gas.

Choose a gas and use the EES viscosity function to determine its viscosity as a function of pressure and temperature. Then calculate and plot the thermal conductivity as a function of pressure at several temperatures. Compare the values you obtain from the dilute gas theory described above with the values provided at the same conditions obtained from the EES conductivity function. Use your program to answer the following questions.

a.) The thermal conductivity of an ideal gas should only depend on temperature. At what pressure does this requirement fail for the temperature and gas you have selected?

Hydrogen is selected as the gas and the inputs are entered in EES:

```
"Problem 1.1-3"  
$UnitSystem SI MASS RAD PA K J  
$TABSTOPS 0.2 0.4 0.6 0.8 3.5 in  
  
T=300 [K]                                "temperature"  
F$='Hydrogen'                             "fluid"  
P_MPa=0.1 [MPa]                           "pressure, in MPa"  
P=P_MPa*convert(MPa, Pa)                  "pressure"
```

<sup>1</sup> Hirschfelder, J.L., Curtiss, C.F., and Bird, R.B., "Molecular Theory of Gases and Liquids", John Wiley and Sons, 1967

The viscosity, specific heat capacity at constant pressure, and molecular weight of the gas ( $\mu$ ,  $c_p$ , and  $MW$ ) are obtained using EES' built-in property function:

<code>mu=viscosity(F\$,T=T,P=P)</code>	"viscosity"
<code>MW=MolarMass(F\$)</code>	"molecular weight"
<code>cP=cp(F\$,T=T,P=P)</code>	"specific heat capacity"

The translation term in the thermal conductivity is estimated using Eq. (2):

<code>k_trans=15*R#*mu/(4*MW)</code>	"translational contribution"
--------------------------------------	------------------------------

The internal term in the thermal conductivity is estimated using Eq. (3):

<code>cP_molar=cP*MW</code>	"specific heat capacity on a molar basis"
<code>k_int=(mu/MW)*(cP_molar-5*R#/2)</code>	"internal contribution"

The dilute gas estimate of the thermal conductivity ( $k_{dilute}$ ) is obtained from Eq. (1) and compared to the value obtained from EES ( $k$ ):

<code>k_dilute=k_trans+k_int</code>	"dilute gas estimate of the thermal conductivity"
<code>k=conductivity(F\$,T=T,P=P)</code>	"conductivity from EES' internal function"

Figure 1 illustrates the conductivity of hydrogen and the dilute gas estimate as a function of pressure at several values of temperature. It appears that the conductivity is independent of pressure up to about 1 MPa for hydrogen, although this value decreases with reduced temperature.

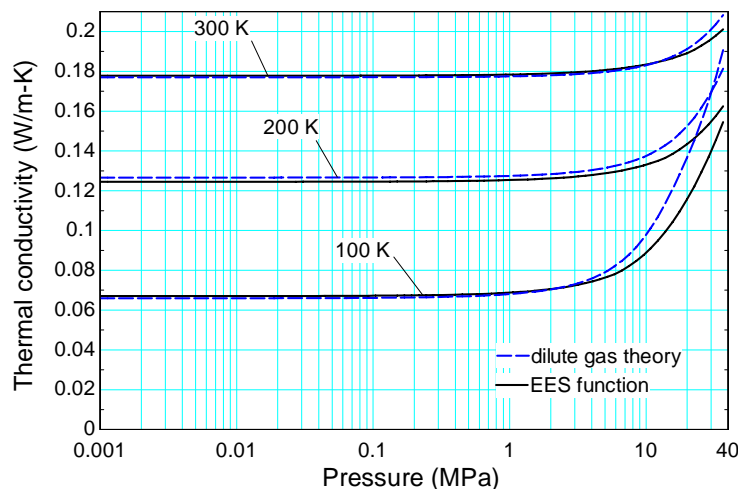

**Figure 1: Thermal conductivity as a function of pressure estimated by the dilute gas theory and using EES internal property routines for several temperatures.**

b.) How does thermal conductivity vary with temperature? What causes this behavior?

Thermal conductivity increases with temperature. This is due to higher molecular velocities (primarily) but also due to more modes of energy storage being activated with temperature.

c.) How does thermal conductivity vary with the choice of gas. Is there any relationship between the thermal conductivity and the number of atoms per molecule?

Figure 2 illustrates the conductivity of 6 different gases at 300 K and 100 kPa. There does not appear to be a clear correlation between conductivity and the number of atoms per molecule.

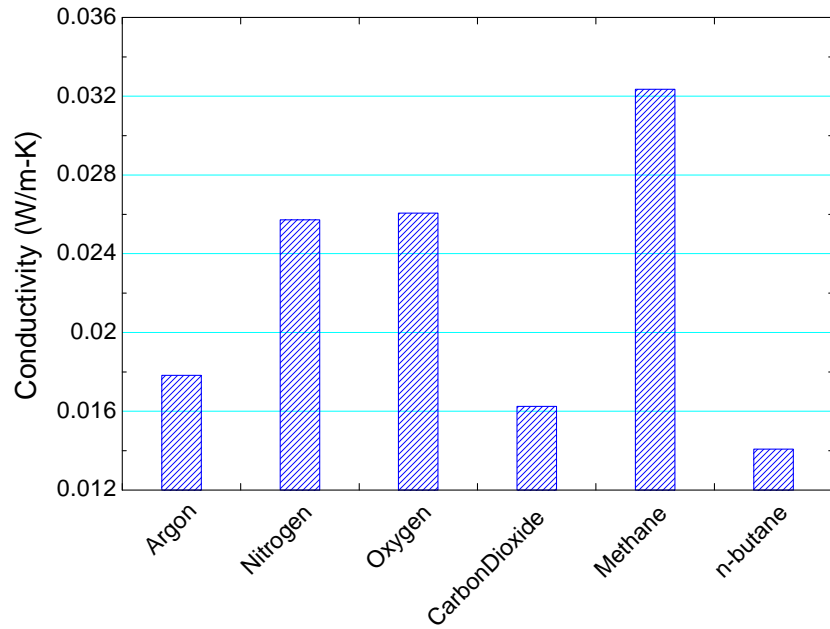

**Figure 2: Thermal conductivity for several gases at 300 K and 100 kPa.**

### PROBLEM 1.2-1: Composite Wall

A plane wall is a composite of a low conductivity material (with thickness  $L_1$  and conductivity  $k_1$ ) and a high conductivity material (with thickness  $L_2 = L_1$  and conductivity  $k_2$ ). The edge of the wall at  $x = 0$  is at temperature  $T_1$  and the edge at  $x = L_1 + L_2$  has temperature  $T_2$ , as shown in Figure P1.2-1(a).  $T_1$  is greater than  $T_2$ . The wall is at steady-state and the temperature distribution in the wall is one-dimensional in  $x$ .

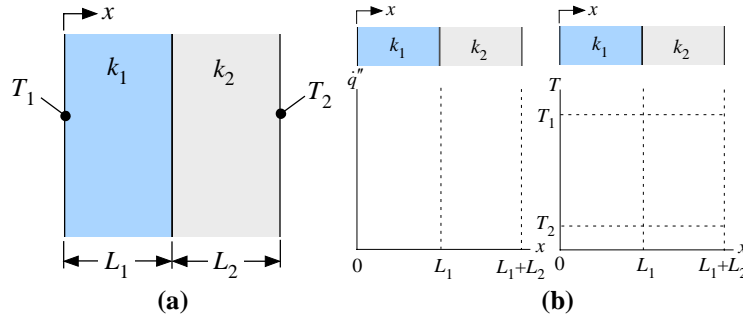

Figure P1.2-1: (a) Composite wall with  $k_1 < k_2$ , and (b) sketch of heat flux and temperature.

- a.) Sketch the heat flux ( $\dot{q}''$ ) and temperature ( $T$ ) as a function of position within the wall on the axes in Fig. 1.2-1(b). Make sure that your sketch reflects the fact that (1) the wall is at steady state, and (2)  $k_1 < k_2$ .

If the process is at steady state, then I can draw a control volume that extends from one surface to any location  $x$  in the material, as shown in Figure 2.

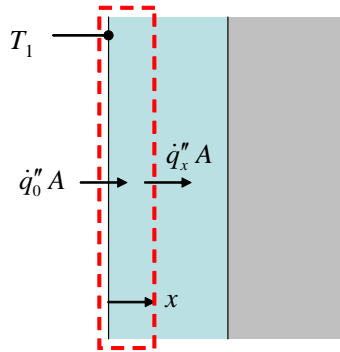

Figure 2: Control volume for solution

An energy balance on the control volume leads to:

$$\dot{q}_0'' A = \dot{q}_x'' A \quad (1)$$

Equation (1) shows that the heat flux at any location  $x$  must be constant. The heat flux associated with conduction is governed by Fourier's law:

$$\dot{q}_x'' = -k \frac{dT}{dx} \quad (2)$$

Solving Eq. (2) for the temperature gradient leads to:

$$\frac{dT}{dx} = -\frac{\dot{q}_x''}{k} \quad (3)$$

The numerator of Eq. (3), the heat flux, is constant while the denominator changes depending on whether you are in material 1 or material 2. In the low conductivity material 1, the temperature gradient will be higher than in the high conductivity material 2. Within each material, the temperature gradient must be constant (i.e., the temperature must be linear with  $x$ ). The solution is shown in Figure 3.

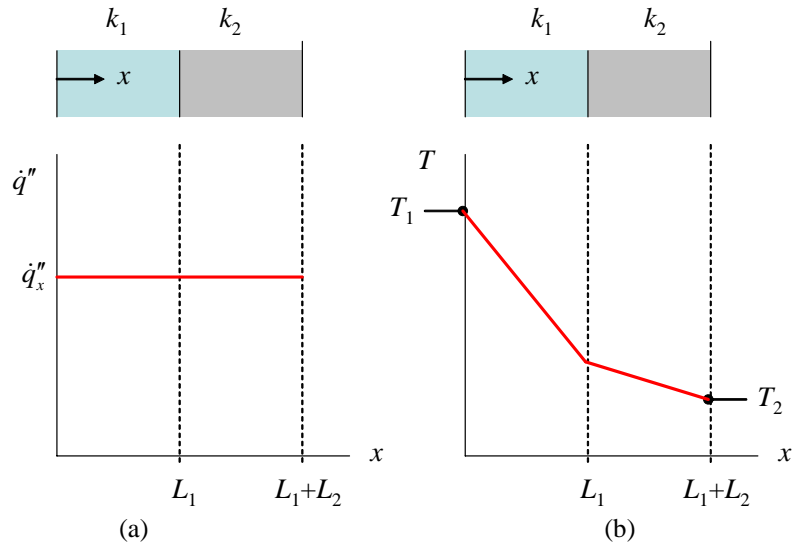

**Figure 3:** (a) Heat transfer rate and (b) temperature as a function of position within wall.

### Problem P1.2-2: Conduction Through a Shape with Varying Cross-sectional Area

The temperature distribution for the shape shown in Figure P1.2-2 can be assumed to be 1-D in the coordinate  $s$ . The problem is at steady state and the area available for conduction changes with  $s$  according to an arbitrary function,  $A(s)$ . The temperatures of the two ends of the shape are specified;  $T_H$  at  $s_1$  and  $T_C$  at  $s_2$ .

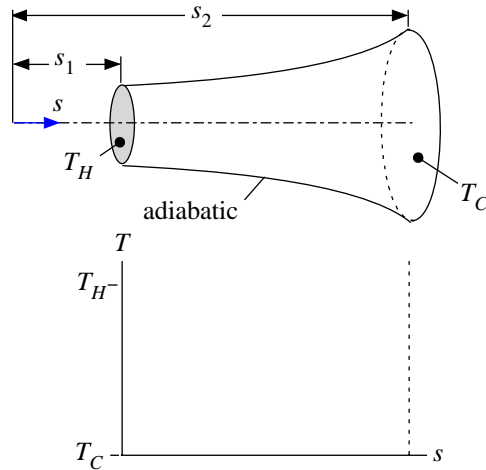

Figure P1.2-2: Conduction through a shape in which the cross-sectional area varies according to  $A(s)$ .

a.) Sketch the temperature distribution through the shape on the axes below the figure.

The rate of conductive heat transfer ( $\dot{q}$ ) at any position  $s$  is given by Fourier's law:

$$\dot{q} = -k A \frac{dT}{ds} \quad (1)$$

At steady state, the heat transfer rate must be constant with position and therefore the temperature gradient is inversely proportional to area:

$$\frac{dT}{ds} = -\frac{\dot{q}}{k A} \quad (2)$$

The temperature gradient will be steepest where the area is smallest, as shown in Figure 2.

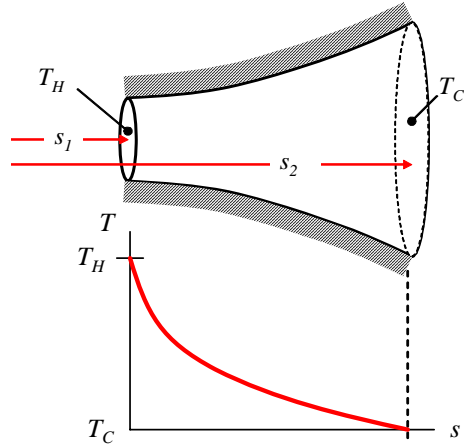

**Figure 2: Temperature distribution.**

- b.) Derive the governing differential equation for the problem; the governing differential equation should include only temperature  $T$  and its derivatives with respect to  $s$  as well as the area and its derivatives with respect to  $s$ .

A differentially small control volume is defined, as shown in Figure 3.

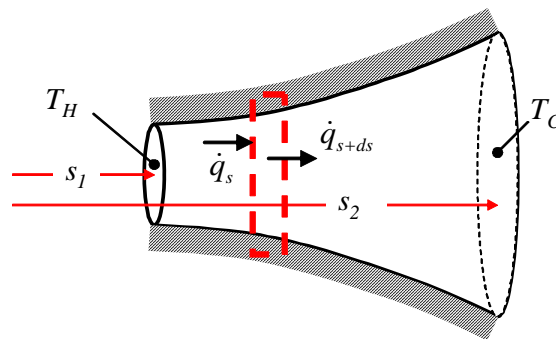

**Figure 3: Differential control volume.**

An energy balance on the control volume leads to:

$$\dot{q}_s = \dot{q}_{s+ds} \quad (3)$$

Expanding the  $s+ds$  term in Eq. (3) leads to:

$$\dot{q}_s = \dot{q}_s + \frac{d\dot{q}}{ds} ds \quad (4)$$

which can be simplified:

$$\frac{d\dot{q}}{ds} = 0 \quad (5)$$

Substituting in Fourier's law into Eq. (5) leads to:

$$\frac{d}{ds} \left[ -k A \frac{dT}{ds} \right] = 0 \quad (6)$$

You can divide through by  $-k$  to get the governing differential equation:

$$\boxed{\frac{d}{ds} \left[ A \frac{dT}{ds} \right] = 0} \quad \text{or} \quad \frac{dA}{ds} \frac{dT}{ds} + A \frac{d^2T}{ds^2} = 0 \quad (7)$$

**Problem 1.2-3 (1-2 in text): Conduction through a Wall**

Figure P1.2-3 illustrates a plane wall made of a very thin ( $th_w = 0.001$  m) and conductive ( $k = 100$  W/m-K) material that separates two fluids, A and fluid B. Fluid A is at  $T_A = 100^\circ\text{C}$  and the heat transfer coefficient between the fluid and the wall is  $\bar{h}_A = 10$  W/m<sup>2</sup>-K while fluid B is at  $T_B = 0^\circ\text{C}$  with  $\bar{h}_B = 100$  W/m<sup>2</sup>-K.

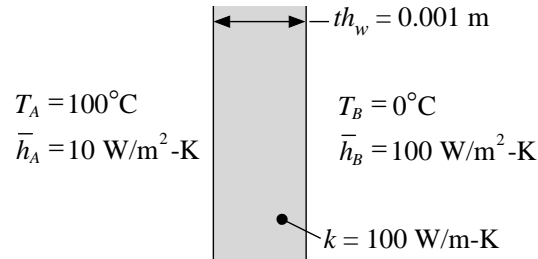

**Figure P1.2-3: Plane wall separating two fluids**

- a.) Draw a resistance network that represents this situation and calculate the value of each resistor (assuming a unit area for the wall,  $A = 1$  m<sup>2</sup>).

Heat flowing from fluid A to fluid B must pass through a fluid A-to-wall convective resistance ( $R_{conv,A}$ ), a resistance to conduction through the wall ( $R_{cond}$ ), and a wall-to-fluid B convective resistance ( $R_{conv,B}$ ). These resistors are in series. The network and values of the resistors are shown in Figure 2.

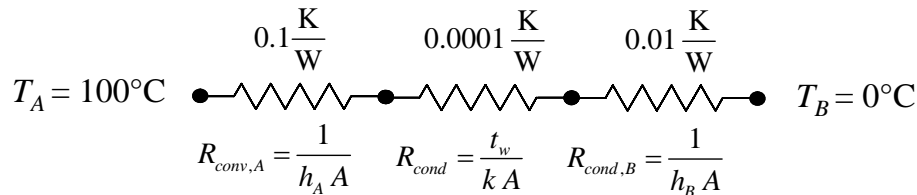

**Figure 2: Thermal resistance network representing the wall.**

- b.) If you wanted to predict the heat transfer rate from fluid A to B very accurately, then which parameter (e.g.,  $th_w$ ,  $k$ , etc.) would you try to understand/measure very carefully and which parameters are not very important? Justify your answer.

The largest resistance in a series network will control the heat transfer. For the wall above, the largest resistance is  $R_{conv,A}$ . Therefore, I would focus on predicting this resistance accurately. This would suggest that  $\bar{h}_A$  is the most important parameter and the others do not matter much.

**Problem 1.2-4 (1-4 in text): Resistance Network**

Figure P1.2-4 illustrates a plane wall that is composed of two materials, A and B. The interface between the materials is characterized by a contact resistance. The left surface of material A is held at  $T_H$  and the right surface of material B radiates to surroundings at  $T_C$  and is also exposed to convection to a fluid at  $T_C$ .

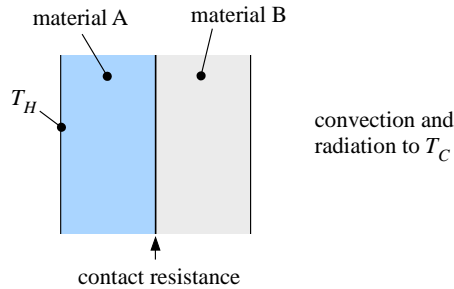

**Figure P1.2-4: Composite wall with contact resistance, convection and radiation**

The resistance network that represents the situation in Figure P1.2-4 should include five thermal resistors; their values are provided below:

$R_{cond,A} = 0.05$  K/W, resistance to conduction through material A

$R_{contact} = 0.01$  K/W, contact resistance

$R_{cond,B} = 0.05$  K/W, resistance to conduction through material B

$R_{conv} = 1.0$  K/W, resistance to convection

$R_{rad} = 10.0$  K/W, resistance to radiation

- a.) Draw a resistance network that represents the situation in Figure P1.2-4. Each resistance in the network should be labeled according to  $R_{cond,A}$ ,  $R_{contact}$ ,  $R_{cond,B}$ ,  $R_{conv}$ , and  $R_{rad}$ . Show where the temperatures  $T_H$  and  $T_C$  appear on your network.

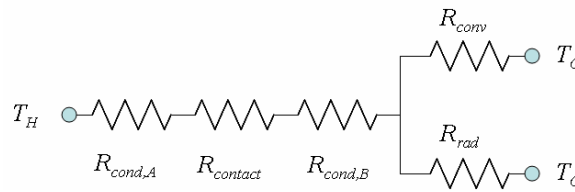

**Figure 2: Resistance network that represents Figure P1.2-4.**

- b.) What is the most important resistor in the network? That is, the heat transfer from  $T_H$  to  $T_C$  is most sensitive to which of the five resistances?

The most important resistor in a series combination is the largest. The largest resistance is the parallel combination of  $R_{conv}$  and  $R_{rad}$ . The most important resistance in a parallel combination is the smallest; the smallest of  $R_{conv}$  and  $R_{rad}$  is  $R_{conv}$ . Thus,  $R_{conv}$  is the most important resistance.

- c.) What is the least important resistor in the network?

The least important resistance is the contact resistance; it is the smallest in a series of resistors that are themselves unimportant relative to convection and radiation.

## Problem 1.2-5

Figure P1.2-5 illustrates a wafer that is being developed in an optical lithography process.

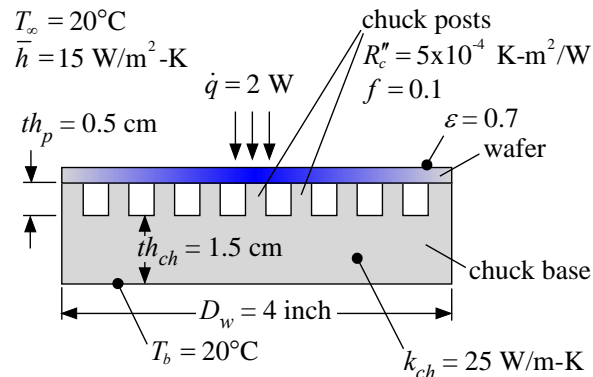

Figure P1.2-5: Wafer being developed in an optical lithography process.

The energy required to develop the resist is deposited at a rate of  $\dot{q} = 2 \text{ W}$  near the center of the upper side of the wafer. The wafer has diameter  $D_w = 4 \text{ inch}$  and is made of a conductive material; therefore, you may assume that the wafer is isothermal. The wafer is cooled by convection and radiation to the surroundings at  $T_\infty$  as well as conduction to the chuck. The surrounding air is at  $T_\infty = 20^\circ\text{C}$  and the heat transfer coefficient is  $\bar{h} = 15 \text{ W/m}^2\text{-K}$ . The emissivity of the wafer surface is  $\varepsilon = 0.7$ . The chuck is made out of a single piece of material with conductivity  $k_{ch} = 25 \text{ W/m-K}$  and consists of a base that is  $th_{ch} = 1.5 \text{ cm}$  thick and an array of posts that are  $th_p = 0.5 \text{ cm}$  tall. The area of the base of the chuck is the same as the area of the wafer. The posts occupy  $f = 10\%$  of the chuck area and the wafer rests on the top of the posts. There is an area specific contact resistance of  $R_c'' = 5 \times 10^{-4} \text{ K-m}^2/\text{W}$  between the bottom of the wafer and the top of the posts. The bottom surface of the chuck base is maintained at  $T_b = 20^\circ\text{C}$ .

a.) What is the temperature of the wafer at steady-state?

The inputs are entered in EES:

```
"Problem 1.2-5"
$UnitSystem SI MASS RAD PA K J
$TABSTOPS 0.2 0.4 0.6 0.8 3.5 in

"Inputs"
D_w=4.0 [inch]*convert(inch,m)
e=0.7 [-]
h_bar=15 [W/m^2-K]
q_dot=2 [W]
th_ch=1.5 [cm]*convert(cm,m)
k_ch=25 [W/m-K]
R_c''=5e-4 [K-m^2/W]
th_p=0.5 [cm]*convert(cm,m)
f = 0.1 [-]
T_infinity_C=20[C]
T_infinity=converttemp(C,K,T_infinity_C)
T_b_C=20 [C]
```

"diameter of wafer"  
"emissivity of wafer"  
"heat transfer coefficient"  
"power"  
"chuck base thickness"  
"chuck conductivity"  
"contact resistance"  
"post height"  
"fraction of post coverage"  
"ambient temperature in C"  
"ambient temperature"  
"chuck base temperature in C"

T\_b=converttemp(C,K,T\_b\_C)

"chuck base temperature"

Note that the inputs are converted to base SI units and the units for each variable are set in the Variables Information window.

The resistance network used to represent this problem is shown in Figure P1.2-5-2:

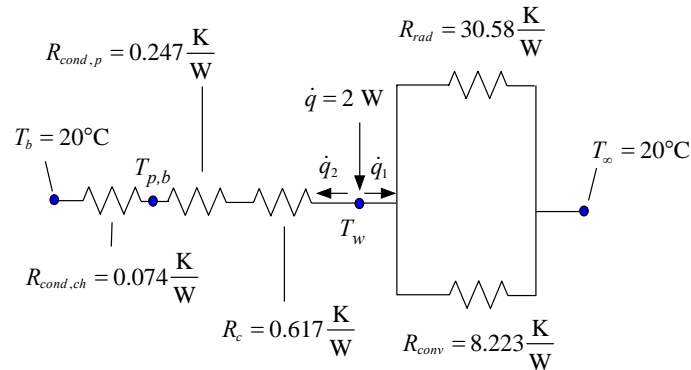

- The resistances include:
- $R_{cond,ch}$  = conduction through chuck base
  - $R_{cond,p}$  = conduction through posts
  - $R_c$  = contact resistance
  - $R_{rad}$  = radiation resistance
  - $R_{conv}$  = convection resistance

Figure P1.2-5-2: Resistance network.

In order to compute the resistance to radiation, it is necessary to guess a value of the wafer temperature ( $T_w$ ) and subsequently comment out this guess in order to close up the solution. A reasonable value is chosen:

T\_w=300 [K]

"guess for wafer temperature - will be commented out"

The cross-sectional area of the wafer is:

$$A_w = \frac{\pi D_w^2}{4} \quad (1)$$

The resistance to convection from the top surface of the wafer is:

$$R_{conv} = \frac{1}{A_w \bar{h}} \quad (2)$$

A\_w=pi\*D\_w^2/4

R\_conv=1/(A\_w\*h\_bar)

"wafer area"

"convection resistance"

The equations should be solved and the units set as you move through the problem (rather than at the end); this prevents the accumulation of small errors that are difficult to debug. The resistance to radiation is:

$$R_{rad} = \frac{1}{A_w \varepsilon (T_w^2 + T_\infty^2)(T_w + T_\infty)} \quad (3)$$

$R_{rad}=1/(A_w*\sigma#*e*(T_w^2+T_\infty^2)*(T_w+T_\infty))$  "radiation resistance"

The contact resistance is:

$$R_c = \frac{R_c''}{A_w f} \quad (4)$$

Notice that the factor  $f$  in the denominator accounts for the contact area between the posts and the wafer.

$R_c=R''_c/(A_w*f)$  "contact resistance"

The resistance to conduction through the posts is:

$$R_{cond,p} = \frac{th_p}{k_{ch} A_w f} \quad (5)$$

and the resistance to conduction through the base is:

$$R_{cond,ch} = \frac{th_{ch}}{k_{ch} A_w} \quad (6)$$

$R_{cond,p}=th_p/(k_{ch}*A_w*f)$

"resistance to conduction through posts"

$R_{cond,ch}=th_{ch}/(k_{ch}*A_w)$

"resistance to conduction through chuck"

The rate of heat transfer by radiation and convection ( $\dot{q}_1$ ) and through the chuck ( $\dot{q}_2$ ) are computed:

$$\dot{q}_1 = \frac{(T_w - T_\infty)}{\left( \frac{1}{R_{conv}} + \frac{1}{R_{rad}} \right)^{-1}} \quad (7)$$

$$\dot{q}_2 = \frac{(T_w - T_b)}{R_c + R_{cond,p} + R_{cond,ch}} \quad (8)$$

$q\_dot\_1=(T_w-T_\infty)/(1/R_{conv}+1/R_{rad})^{(-1)}$

"rate of heat transfer by convection and radiation"

$q\_dot\_2=(T_w-T_b)/(R_c+R_{cond,p}+R_{cond,ch})$

"rate of heat transfer to chuck"

Because we guessed a value for  $T_w$ , it is not likely that  $\dot{q}_1$  and  $\dot{q}_2$  sum to the applied power to the wafer, as required by an energy balance:

$$\dot{q} = \dot{q}_1 + \dot{q}_2 \quad (9)$$

In order to finish the solution it is necessary to vary  $T_w$  until an energy balance is satisfied. EES automates this process; however, it will work best if it starts from a good set of guess values. Therefore, select Update Guesses from the Calculate menu. Then comment out the assumed value of  $T_w$ :

```
{T_w=300 [K]} "guess for wafer temperature - will be commented out"
```

and enter the energy balance:

```
q_dot=q_dot_1+q_dot_2 "energy balance"
T_w_C=converttemp(K,C,T_w) "wafer temperature in C"
```

which leads to  $T_w = 294.8 \text{ K}$  ( $21.64^\circ\text{C}$ ).

b.) Prepare a plot showing the wafer temperature as a function of the applied power,  $\dot{q}$ .

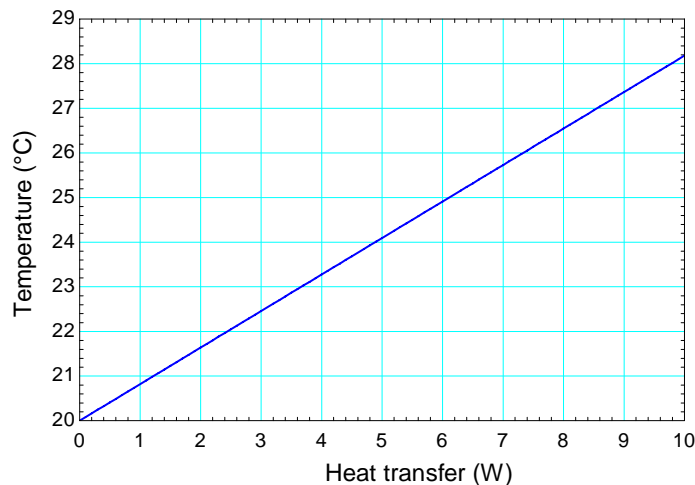

**Figure P1.2-5-3: Wafer temperature as a function of applied power.**

c.) What are the dominant heat transfer mechanisms for this problem? What aspects of the problem are least important?

The values of the resistances at the nominal conditions given in the problem statement are shown in Figure P1.2-5-2. The value of the radiation and convection resistances are both large relative to the sum of resistances between  $T_w$  and  $T_b$  and therefore these mechanisms are not likely to play an important role in the problem. The resistance to conduction through the base of the chuck is small relative to the resistance to conduction through the posts and the contact resistance; therefore, conduction through the chuck base is not very important. The dominant

resistance in the problem is the contact resistance and the resistance to conduction through the posts is also important.

d.) Radiation between the underside of the wafer and the top of the chuck base was ignored in the analysis; is this an important mechanism for heat transfer? Assume that the chuck surface is black and justify your answer.

The resistance network, modified to include the resistance to radiation from the bottom of the wafer to the top of the chuck, is shown in Figure P1.2-5-4.

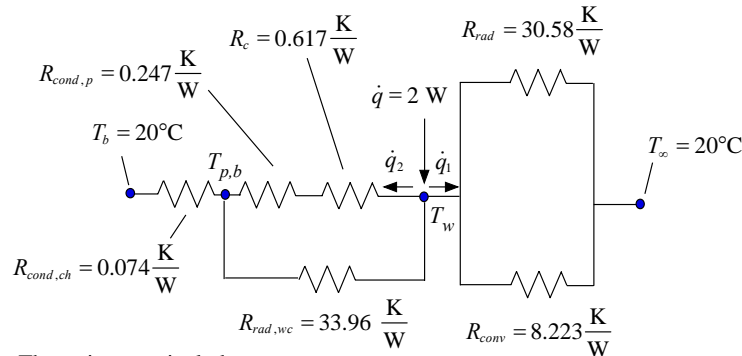

The resistances include:  
 $R_{cond,ch}$  = conduction through chuck base  
 $R_{cond,p}$  = conduction through posts  
 $R_c$  = contact resistance  
 $R_{rad}$  = radiation resistance  
 $R_{conv}$  = convection resistance  
 $R_{rad,wc}$  = radiation resistance from top of chuck to bottom of wafer

**Figure P1.2-5-4: Resistance network, including radiation from the wafer bottom.**

The temperature of the top of the chuck is estimated using our previous solution:

$$T_{p,b} = T_w - \dot{q}_1 (R_c + R_{cond,p}) \quad (10)$$

and used to estimate the resistance to radiation from the top of the chuck to the bottom of the wafer:

$$R_{rad,wc} = \frac{1}{(1-f) A_w \varepsilon (T_w^2 + T_{p,b}^2) (T_w + T_{p,b})} \quad (11)$$

$T_{p,b} = T_w - \dot{q}_1 (R_c + R_{cond,p})$  "temperature of the top surface of chuck"  
 $R_{rad,wc} = 1 / ((1-f) * A_w * \varepsilon * (T_w^2 + T_{p,b}^2) * (T_w + T_{p,b}))$   
 "radiation resistance between bottom of wafer and top of chuck"

which leads to  $R_{rad,wc} = 33.96 \text{ K/W}$ . Because  $R_{rad,wc}$  is in series with  $R_c$  and  $R_{cond,p}$  and much larger than the sum of these resistances it is not very important to the problem.

- e.) In an effort to maintain the wafer temperature at  $T_w = 20^\circ\text{C}$ , you decide to try to reduce and control the chuck base temperature,  $T_b$ . What temperature do you need to reduce  $T_b$  to in order that  $T_w = 20^\circ\text{C}$ ? If you can only control  $T_b$  to within  $\pm 0.5$  K then how well can you control  $T_w$ ?

The specified chuck temperature is commented out and instead the wafer temperature is specified:

```
{T_b_C=20 [C]}           "chuck base temperature in C"
T_w_C=20 [C]             "specified wafer temperature"
```

which leads to  $T_b = 291.3$  K ( $18.13^\circ\text{C}$ ). In order to evaluate the impact of a  $\pm 0.5$  K fluctuation of  $T_b$  on  $T_w$ , the required value of  $T_b$  is specified and the value of  $T_w$  is again commented out:

```
T_b_C=18.13 [C]         "chuck base temperature in C"
{T_w_C=20 [C]}          "specified wafer temperature"
```

which leads to  $T_w = 293.2$  K ( $20^\circ\text{C}$ ), as expected. Now the value of  $T_b$  is elevated by 0.5 K in order to determine the impact on  $T_w$ :

```
T_b_C=18.13 [C] + 0.5 [K]  "chuck base temperature in C"
```

which leads to  $T_w = 293.6$  K ( $20.44^\circ\text{C}$ ). Therefore, the  $\pm 0.5$  K uncertainty in  $T_b$  leads to a  $\pm 0.44$  K uncertainty in  $T_w$ .

- f.) Perform the same analysis you carried out in (e), but this time evaluate the merit of controlling the surrounding temperature,  $T_\infty$ , rather than the chuck temperature. What are the advantages and disadvantages associated with controlling  $T_\infty$ ?

The chuck temperature is returned to  $20^\circ\text{C}$ :

```
T_b_C=20 [C]           "chuck base temperature in C"
```

The specified surrounding temperature is commented out and instead the wafer temperature is specified:

```
{T_infinity_C=20[C]}     "ambient temperature in C"
T_w_C=20 [C]             "specified wafer temperature"
```

which leads to  $T_\infty = 280.0$  K ( $6.835^\circ\text{C}$ ); clearly the ambient temperature would need to be reduced by much more than the chuck temperature due to the weaker interaction between the wafer and the surroundings. This is a disadvantage of using the ambient temperature to control the wafer temperature.

In order to evaluate the impact of a  $\pm 0.5$  K fluctuation of  $T_\infty$  on  $T_w$ , the required value of  $T_\infty$  is specified and the value of  $T_w$  is again commented out:

```
T_infinity_C=6.835 [C]  "ambient temperature in C"
```

{T\_w\_C=20 [C] "specified wafer temperature"}

which leads to  $T_w = 293.2$  K (20°C), as expected. Now the value of  $T_\infty$  is elevated by 0.5 K in order to determine the impact on  $T_w$ :

T\_infinity\_C=6.835 [C]+0.5 [K] "ambient temperature in C"

which leads to  $T_w = 293.2$  K (20.06°C). Therefore, the  $\pm 0.5$  K uncertainty in  $T_\infty$  leads to a  $\pm 0.06$  K uncertainty in  $T_w$ . This is an advantage of using  $T_\infty$  to control the wafer temperature and is also related to the relatively weak thermal interaction between  $T_\infty$  and  $T_w$ .

### P1.2-6: Freezer Wall

You have designed a wall for a freezer. A cross-section of your freezer wall is shown in Figure P1.2-6. The wall separates the freezer air at  $T_f = -10^\circ\text{C}$  from air within the room at  $T_r = 20^\circ\text{C}$ . The heat transfer coefficient between the freezer air and the inner wall of the freezer is  $\bar{h}_f = 10 \text{ W/m}^2\text{-K}$  and the heat transfer coefficient between the room air and the outer wall of the freezer is  $\bar{h}_r = 10 \text{ W/m}^2\text{-K}$ . The wall is composed of a  $th_b = 1.0 \text{ cm}$  thick layer of fiberglass blanket sandwiched between two  $th_w = 5.0 \text{ mm}$  sheets of stainless steel. The thermal conductivity of fiberglass and stainless steel are  $k_b = 0.06 \text{ W/m-K}$  and  $k_w = 15 \text{ W/m-K}$ , respectively. Assume that the cross-sectional area of the wall is  $A_c = 1 \text{ m}^2$ . Neglect radiation from either the inner or outer walls.

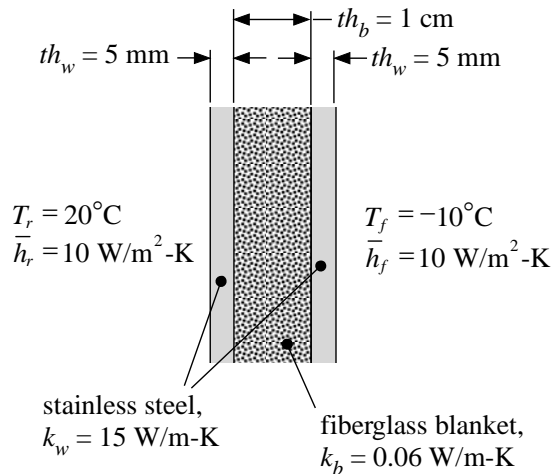

Figure P1.2-6: Freezer wall.

- a.) Draw a resistance network to illustrate this problem. Be sure to label the resistances in your network so that it is clear what each resistance is meant to represent.

There are five resistances associated with the problem; convection to the room and the freezer,  $R_{conv,r}$  and  $R_{conv,f}$ , and conduction through each of the stainless steel walls and the fiberglass blanket,  $R_{cond,w}$  and  $R_{cond,f}$ . These are placed in series since the heat transfer must pass through all of them, as shown in Figure P1.2-6-2.

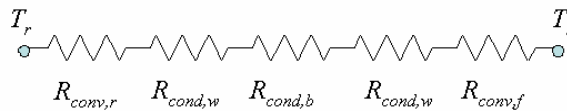

Figure P1.2-6-2: Thermal resistance network.

- b.) Enter all of the inputs in the problem into an EES program. Convert each input into the corresponding base SI unit (i.e., m, kg, K, W, N, etc.) and set the unit for each variable using the Variable Information window. Using comments, indicate what each variable means. Make sure that you set and check units of each variable that you use in the remainder of the solution process.

The inputs are entered in EES and converted to base SI:

```

$UnitSystem SI MASS RAD PA K J
$TABSTOPS 0.2 0.4 0.6 0.8 3.5 in

"Inputs"
t_w = 5.0 [mm]*convert(mm,m)           "SS wall thickness"
t_b = 1.0 [cm]*convert(cm,m)          "fiberglass thickness"
T_r = converttemp(C,K,20)             "room air temperature"
h_r = 10 [W/m^2-K]                    "room air to outer wall heat transfer coefficient"
k_w = 15 [W/m-K]                      "SS conductivity"
k_b = 0.06 [W/m-K]                   "fiberglass conductivity"
h_f = 10 [W/m^2-K]                   "freezer air to inner wall heat transfer coefficient"
T_f_C=-10 [C]                        "freezer temperature in C"
T_f = converttemp(C,K,T_f_C)         "freezer air temperature in K"
A = 1 [m^2]                          "freezer area"

```

The units for each variable are set in the Variable Information window (see Figure P1.2-6-3).

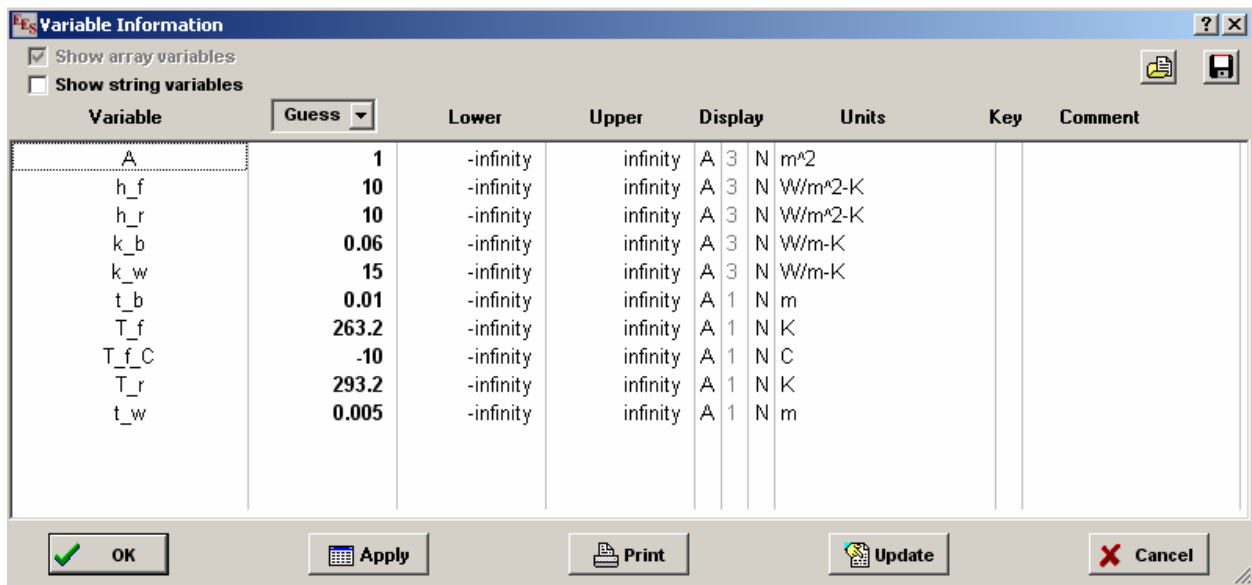

Figure P1.2-6-3: Variable Information window

c.) Calculate the net heat transfer to the freezer (W).

The values of each of the resistances in Figure P1.2-6-2 are calculated. The convection resistances between the room air and the outer wall of the freezer and the freezer air and the inner wall are:

$$R_{conv,r} = \frac{1}{h_r A} \quad (1)$$

$$R_{conv,f} = \frac{1}{h_f A} \quad (2)$$

R\_conv\_r = 1/(h\_r\*A)  
R\_conv\_f=1/(h\_f\*A)

"convection resistance with room air"  
"convection resistance with freezer air"

The units of the two resistances are set in the Variable Information window (to K/W) and the units are checked to ensure that the equations entered are dimensionally consistent.

The two conduction resistances are:

$$R_{cond,w} = \frac{t_w}{k_w A} \quad (3)$$

$$R_{cond,b} = \frac{t_b}{k_b A} \quad (4)$$

R\_cond\_w=t\_w/(k\_w\*A)  
R\_cond\_b=t\_b/(k\_b\*A)

"conduction resistance through SS wall"  
"conduction resistance through fiberglass wall"

The total heat transfer through the wall ( $\dot{q}$ ) is:

$$\dot{q} = \frac{(T_r - T_f)}{R_{conv,r} + 2R_{cond,w} + R_{cond,b} + R_{conv,f}} \quad (5)$$

q\_dot=(T\_r-T\_f)/(R\_conv\_r+R\_cond\_w+R\_cond\_b+R\_cond\_w+R\_conv\_f)  
"net heat transfer to freezer"

The Solution Window is shown in Figure P1.2-6-4, the heat load on the freezer is 81.7 W per m<sup>2</sup> of wall area.

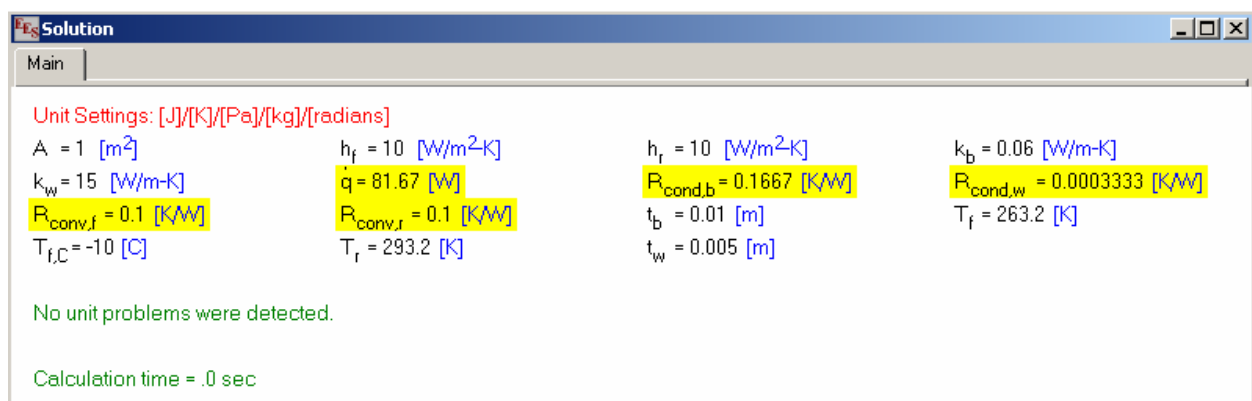

Figure P1.2-6-4: Solution window.

- d.) Your boss wants to make a more energy efficient freezer by reducing the rate of heat transfer to the freezer. He suggests that you increase the thickness of the stainless steel wall panels in order to accomplish this. Is this a good idea? Justify your answer briefly.

The value of the resistances are highlighted in Figure P1.2-6.4. Notice that  $R_{cond,w}$  is approximately 1000x less than the others. Your boss' idea is not so good because in a series combination of resistances, it is the large resistances that dominate the problem. The wall is not important from a heat transfer standpoint.

- e.) Prepare a plot showing the heat transfer to the freezer as a function of the thickness of the stainless steel walls. Prepare a second plot showing the heat transfer to the freezer as a function of the thickness of the fiberglass. Make sure that your plots are clear (axes are labeled, etc.)

A parametric table must be created to vary the thickness of the steel walls. Select New Parametric Table from the Tables menu (Figure P1.2-6-5) and place the variables  $q_{dot}$  and  $t_w$  in the table (highlight these variables from the list in the left hand box and select Add, then hit OK).

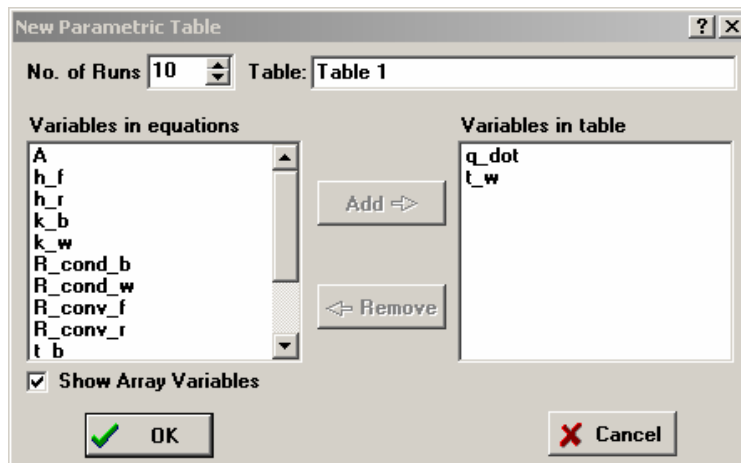

Figure P1.2-6-5: New Parametric Table dialog

Vary the thickness of the stainless steel walls from 0 to 2.0 cm (which corresponds to an extremely heavy freezer); right-click on the column of the parametric table that contains the variable  $t_w$  and select Alter Values (Figure P1.2-6-6).

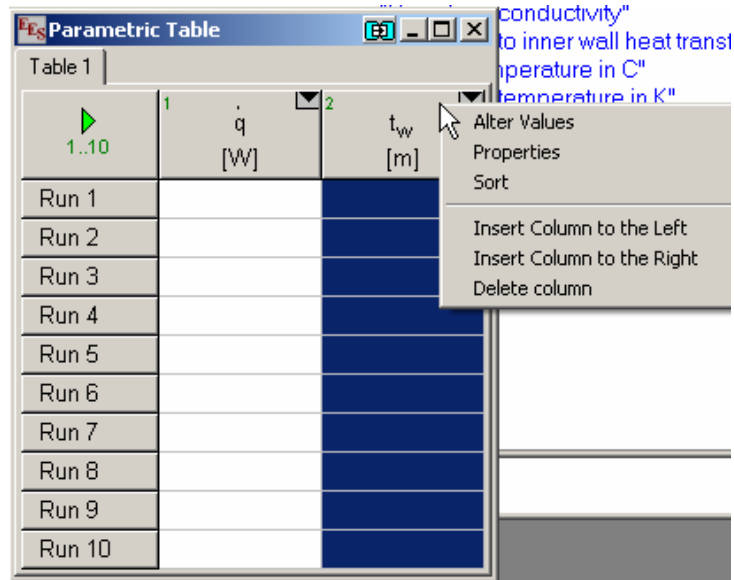

Figure P1.2-6-6: Alter values of  $t_w$  to carry out the parametric investigation.

A dialog window will open asking what range you would like to vary  $t_w$  over; select 0 to 0.02 m (Figure P1.2-6-7) and hit OK.

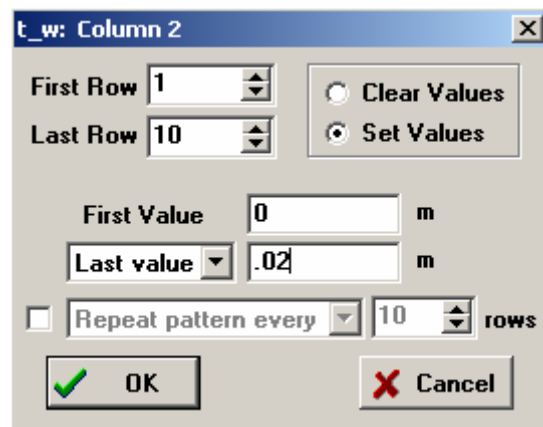
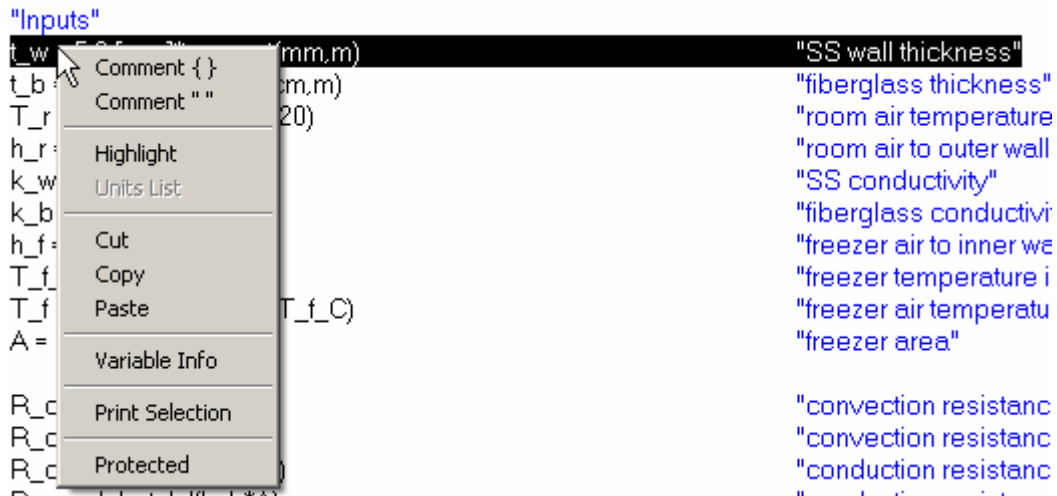

Figure P1.2-6-7: Vary  $t_w$  from 0 to 0.02 m.

The entries in the  $t_w$  column will be automatically filled in. Each time one row of the Table is solved, the corresponding value of  $t_w$  will be used in the Equations Window; therefore, it is necessary to remove the value of  $t_w$  from the Equations Window. In order to do this temporarily (you will want to go back to the value in the problem statement), you should highlight the section of the code that specifies the value and right click. Select Comment to temporarily remove the code (Figure P1.6-2-8); subsequently performing the same operation and selecting Undo Comment will remove the comment indicators and “reactivate” the assignment.



**Figure P1.2-6-8: Comment out the assignment of  $t_w$  in the Equation window**

Solve the table by selecting Solve Table from the Calculate menu; the corresponding value of  $q_{\text{dot}}$  will be entered in each row of the parametric table (Figure P1.2-6-9).

1	2	2
▶ 1..10	$\dot{q}$ [W]	$t_w$ [m]
Run 1	81.82	0
Run 2	81.75	0.002222
Run 3	81.69	0.004444
Run 4	81.62	0.006667
Run 5	81.55	0.008889
Run 6	81.49	0.01111
Run 7	81.42	0.01333
Run 8	81.36	0.01556
Run 9	81.29	0.01778
Run 10	81.23	0.02

**Figure P1.2-6-9: Parametric table with solution**

The solution can be plotted by selecting New Plot Window from the Plots menu and then X-Y plot to bring up the dialog shown in Figure P1.2-6-10. Select the source of the data (there is only one source in your EES file which is the single parametric table that exists) and specify that  $t_w$  will be on the x-axis and  $q_{\text{dot}}$  on the y-axis.

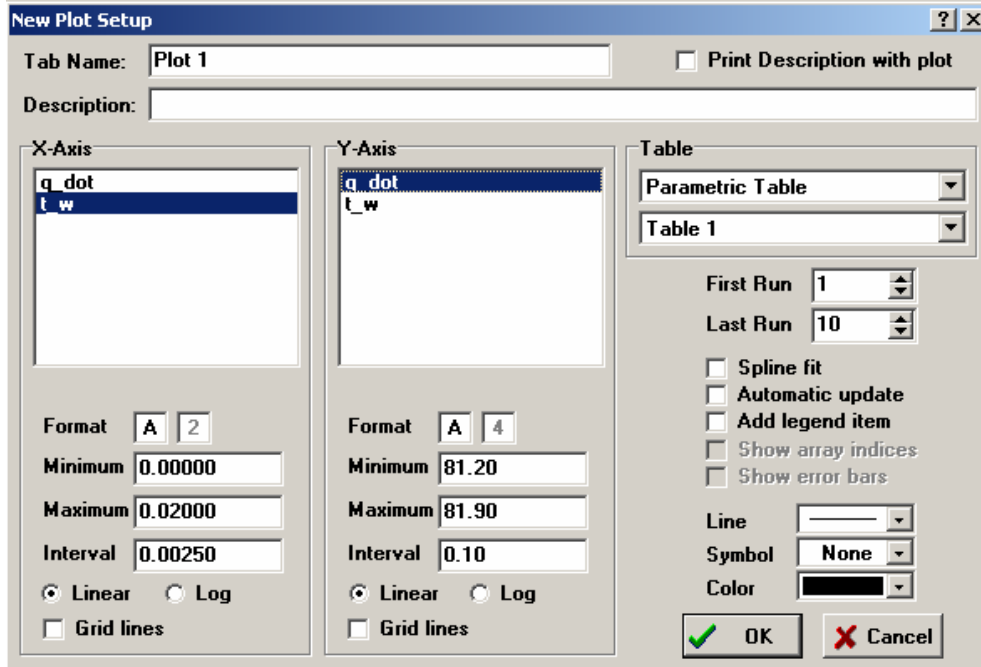

Figure P1.2-6-10: New Plot Setup window.

Select OK to create the plot and then edit it so that it looks good (include axes with descriptive names and units, grid line, etc.); the result should be similar to Figure P1.2-6-11.

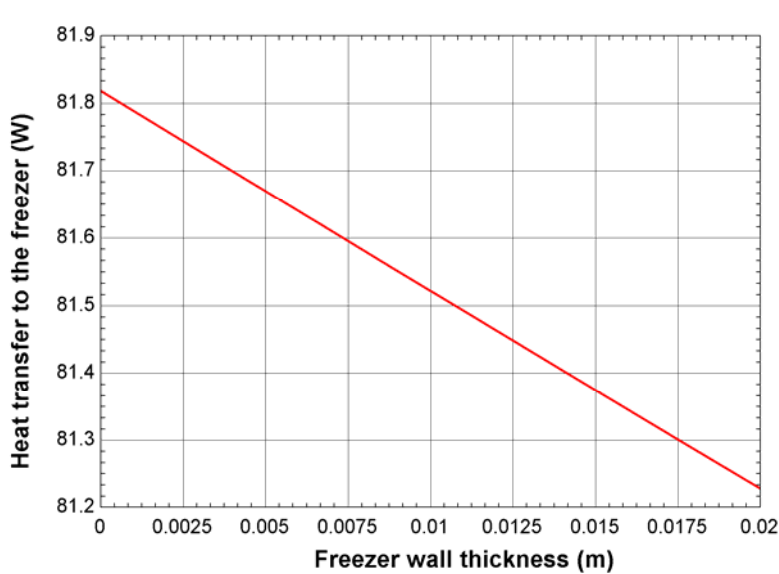

Figure P1.2-6-11: Heat transfer to the freezer as a function of the freezer wall thickness.

Follow the same steps to generate Figure P1.2-6-12, which shows the freezer load as a function of the fiberglass thickness. Note that you will need to un-comment the line in the code where you specify the wall thickness.

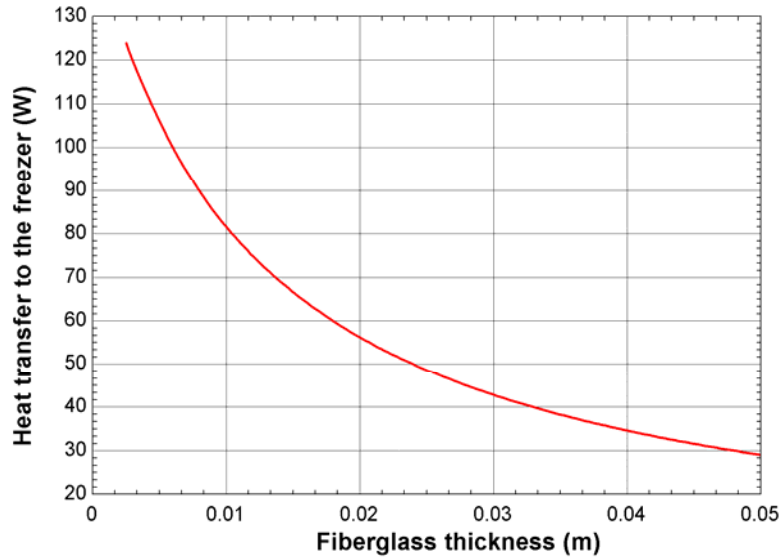

Figure P1.2-6-12: Heat transfer to the freezer as a function of the fiberglass thickness.

- f.) What design change to your wall would you suggest in order to improve the energy efficiency of the freezer.

The largest resistance in Figure P1.2-6-4 is the conduction resistance through the fiberglass; I suggest that the thickness be increased.

- g.) One of your design requirements is that no condensation must form on the external surface of your freezer wall, even if the relative humidity in the room reaches 75%. This implies that the temperature of the external surface of the freezer wall must be greater than 15°C. Does your freezer wall satisfy this requirement? Calculate the external surface temperature (°C).

The temperature at the surface of the freezer wall ( $T_s$ ) corresponds to the node between  $R_{conv,r}$  and  $R_{cond,w}$  in Figure P1.2-6-2; the value of this temperature can be calculated according to:

$$T_s = T_r - \dot{q} R_{conv,r} \quad (6)$$

```
T_s = T_r - q_dot*(R_conv_r + R_cond_w)           "surface temperature"
T_s_C = converttemp(K,C,T_s)                   "surface temperature in C"
```

The solution indicates that  $T_s = 11.8^\circ\text{C}$  which is less than  $15^\circ\text{C}$  and therefore condensation on the outside of the freezer is likely.

- h.) In order to prevent condensation, you suggest placing a heater between the outer stainless steel wall and the fiberglass. How much heat would be required to keep condensation from forming? Assume that the heater is very thin and conductive.

The addition of the heater provides an additional heat input ( $\dot{q}_w$ ) to the resistance network that enters between  $R_{cond,w}$  and  $R_{cond,b}$  on the air-side of the circuit, as shown in Figure P1.2-6-13.

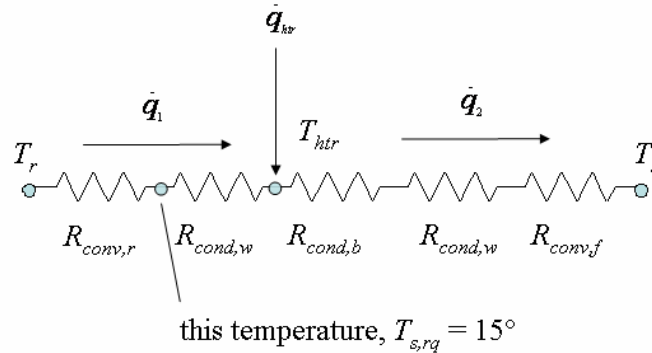

**Figure P1.2-6-13: Heater power added to the resistance network.**

The required surface temperature is  $T_{s,rq} = 15^\circ\text{C}$ . Therefore, the heat transfer through  $R_{conv,r}$  ( $\dot{q}_1$ ) is:

$$\dot{q}_1 = \frac{(T_r - T_{s,rq})}{R_{conv,r}} \quad (7)$$

"With the heater added"

`T_s_rq = converttemp(C,K,15)`  
`q_dot_1=(T_r-T_s_rq)/R_conv_r`

"required surface temperature"  
 "heat transfer from the room"

The heater temperature ( $T_{htr}$ ) is therefore:

$$T_{htr} = T_{s,rq} - \dot{q}_1 R_{cond,w} \quad (8)$$

and the heat transfer to the freezer space ( $\dot{q}_2$ ) is:

$$\dot{q}_2 = \frac{(T_{htr} - T_f)}{R_{cond,b} + R_{cond,w} + R_{conv,f}} \quad (9)$$

The heat transfer required by the heater ( $\dot{q}_{htr}$ ) is obtained by an energy balance on the heater node:

$$\dot{q}_{htr} = \dot{q}_2 - \dot{q}_1 \quad (10)$$

`T_htr=T_s_rq-q_dot_1*R_cond_w`

`q_dot_2=(T_htr-T_f)/(R_cond_b+R_cond_w+R_conv_f)`

`q_dot_htr=q_dot_2-q_dot_1`

"heater temperature"

"heat transfer to freezer space"

"heater power"

The solution indicates that  $\dot{q}_{htr} = 43.6 \text{ W}$ .

- i.) Prepare a plot showing the amount of heat required by the heater as a function of the freezer air temperature.

The plot is generated following essentially the same steps discussed in part (e) and shown in Figure P1.2-6-14.

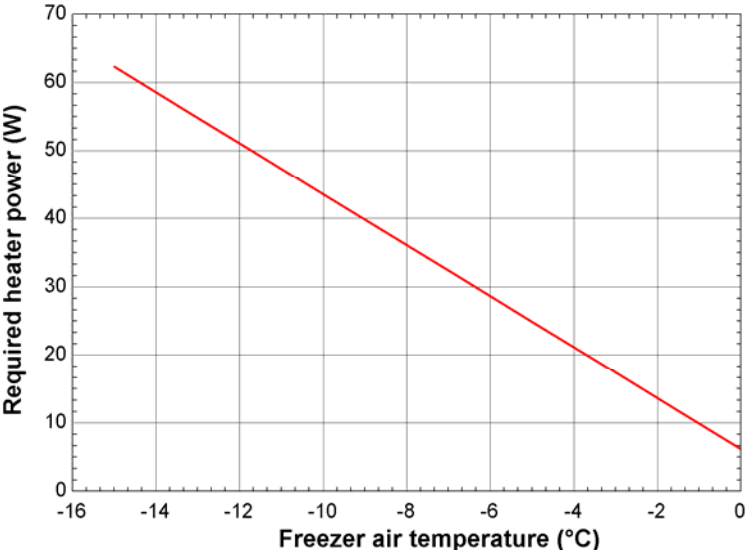

Figure P1.2-6-14: Heater power as a function of the freezer air temperature.

### Problem 1.2-7: Measuring Contact Resistance

You have designed the experimental apparatus shown in Figure P1.2-7 to measure contact resistance. Four thermocouples (labeled  $TC_1$  through  $TC_4$ ) are embedded in two sample blocks at precise locations. The thermocouples are placed  $L_1 = 0.25$  inch from the edges of the sample blocks and  $L_2 = 1.0$  inch apart, as shown. Heat is applied to the top of the apparatus and removed from the bottom using a flow of coolant. The sides of the sample blocks are insulated. The sample blocks are fabricated from an alloy with a precisely-known and nearly constant thermal conductivity,  $k_s = 2.5$  W/m-K. The apparatus is activated and allowed to reach steady state. The temperatures recorded by the thermocouples are  $TC_1 = 53.3^\circ\text{C}$ ,  $TC_2 = 43.1^\circ\text{C}$ ,  $TC_3 = 22.6^\circ\text{C}$ , and  $TC_4 = 12.3^\circ\text{C}$ . The contact resistance of interest is the interface between the sample blocks.

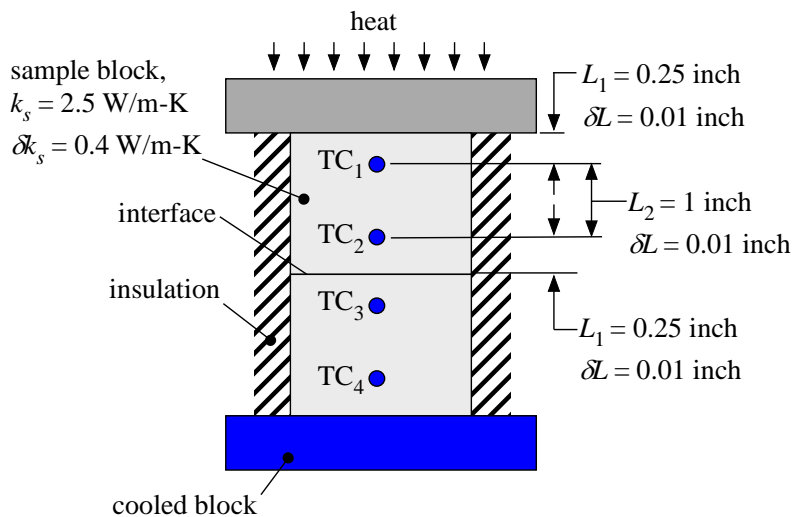

Figure P1.2-7: Experimental device to measure contact resistance.

- a.) Use the data provided above to compute the measured heat flux in the upper and lower sample blocks.

The input parameters are entered in EES:

```
"P1.2-7 "
$UnitSystem SI MASS RAD PA K J
$TABSTOPS 0.2 0.4 0.6 0.8 3.5 in

k_s=2.5 [W/m-K]                    "conductivity"
L_1=0.25 [inch]*convert(inch,m)    "distance between sensor and interface"
L_2=1.0 [inch]*convert(inch,m)     "distance between sensors"
TC_1=converttemp(C,K,53.3)         "thermocouple 1 measurement"
TC_2=converttemp(C,K,43.1)         "thermocouple 2 measurement"
TC_3=converttemp(C,K,22.6)         "thermocouple 3 measurement"
TC_4=converttemp(C,K,12.3)         "thermocouple 4 measurement"
```

The heat transfer through the sample blocks is one-dimensional, steady state conduction through a constant cross-sectional area and therefore the heat flux through the upper and lower sample blocks are given by:

$$\dot{q}_1'' = k_s \frac{(TC_1 - TC_2)}{L_2} \quad (1)$$

$$\dot{q}_2'' = k_s \frac{(TC_3 - TC_4)}{L_2} \quad (2)$$

q\_flux\_1=(TC\_1-TC\_2)\*k\_s/L\_2  
q\_flux\_2=(TC\_3-TC\_4)\*k\_s/L\_2

"heat flux in hot block"  
"heat flux in cold block"

The heat flux measurements are  $\dot{q}_1'' = 1004 \text{ W/m}^2$  and  $\dot{q}_2'' = 1014 \text{ W/m}^2$ . Note that these values should be the same but are different due to measurement uncertainty or heat loss through the insulation.

b.) Use the data to compute the temperature on the hot and cold sides of the interface.

Figure 2 illustrates the measured temperatures as a function of position; the temperatures on the hot and cold sides of the interface ( $T_h$  and  $T_c$ ) can be obtained by extrapolating the temperature gradient to the interface, as shown in Figure 2.

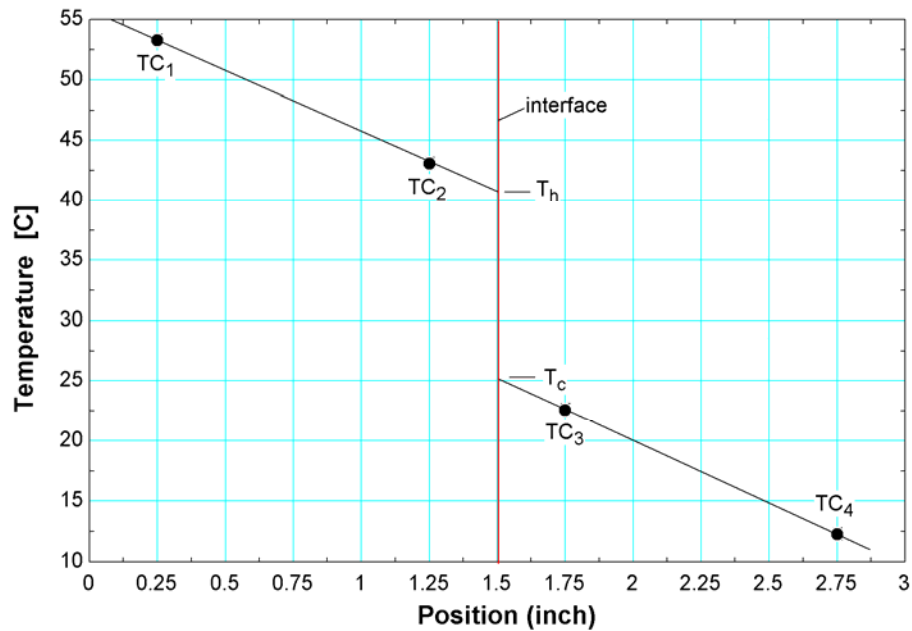

Figure 2: Measured temperatures as a function of position and extrapolated temperatures at the interface.

The temperatures at the hot and cold sides of the interface are estimated according to:

$$T_h = TC_2 - (TC_1 - TC_2) \frac{L_1}{L_2} \quad (3)$$

$$T_c = TC_3 + (TC_3 - TC_4) \frac{L_1}{L_2} \quad (4)$$

$T_h = TC_2 - (TC_1 - TC_2) * L_1 / L_2$	"extrapolated temperature at the hot interface"
$T_c = TC_3 + (TC_3 - TC_4) * L_1 / L_2$	"extrapolated temperature at the cold interface"

The extrapolated temperatures at the interface are  $T_h = 313.7$  K and  $T_c = 298.3$  K.

c.) Use the data to compute the measured contact resistance.

The average of the two heat flux measurements is:

$$\dot{q}'' = \frac{(\dot{q}_1'' + \dot{q}_2'')}{2} \quad (5)$$

The measured value of the contact resistance is therefore:

$$R_c'' = \frac{(T_h - T_c)}{\dot{q}''} \quad (6)$$

$q\_flux = (q\_flux\_1 + q\_flux\_2) / 2$	"average of heat flux calculations"
$R\_contact = (T\_h - T\_c) / q\_flux$	"measured contact resistance"

The measured contact resistance is  $R_c'' = 0.0152$  K-m<sup>2</sup>/W.

It is important to estimate the uncertainty in your measurement. The uncertainty in the distance measurements is  $\delta L = 0.01$  inch, the uncertainty in the conductivity of the sample blocks is  $\delta k_s = 0.4$  W/m-K, and the uncertainty in the temperature measurements is  $\delta T = 0.5$  K.

d.) Estimate the uncertainty in the measurement of the heat flux in the upper sample block, the answer for (a), manually; that is carry out the uncertainty propagation calculations explicitly.

The uncertainties are entered in EES:

$dk\_s = 0.1$ [W/m-K]	"uncertainty in conductivity"
$dL = 0.01$ [inch]*convert(inch,m)	"uncertainty in position measurements"
$dT = 0.5$ [K]	"uncertainty in temperature measurement"

The uncertainty in  $\dot{q}_1''$  is related to the uncertainty in the measured quantities used to calculate  $\dot{q}_1''$ :

$$\dot{q}_1'' = k_s \frac{(TC_1 - TC_2)}{L_2} \quad (7)$$

The uncertainty in  $\dot{q}_1''$  due to  $TC_1$  ( $\delta \dot{q}_{1,TC_1}''$ ) is obtained according to:

$$\delta \dot{q}_{1,TC_1}'' = \frac{\partial \dot{q}_1''}{\partial TC_1} \delta T = k_s \frac{\delta T}{L_2} \quad (8)$$

and the uncertainty in  $\dot{q}_1''$  due to  $TC_2$  ( $\delta \dot{q}_{1,TC_2}''$ ) is also:

$$\delta \dot{q}_{1,TC_2}'' = k_s \frac{\delta T}{L_2} \quad (9)$$

The uncertainty in  $\dot{q}_1''$  due to  $k_s$  ( $\delta \dot{q}_{1,k_s}''$ ) is:

$$\delta \dot{q}_{1,k_s}'' = (TC_1 - TC_2) \frac{\delta k_s}{L_2} \quad (10)$$

and the uncertainty in  $\dot{q}_1''$  due to  $L_2$  ( $\delta \dot{q}_{1,L_2}''$ ) is:

$$\delta \dot{q}_{1,L_2}'' = k_s (TC_1 - TC_2) \frac{\delta L}{L_2^2} \quad (11)$$

The total uncertainty in the heat flux is obtained by combining these contributions using the root-sum-square (RSS) technique:

$$\delta \dot{q}_1'' = \sqrt{\delta \dot{q}_{1,TC_1}''^2 + \delta \dot{q}_{1,TC_2}''^2 + \delta \dot{q}_{1,k_s}''^2 + \delta \dot{q}_{1,L_2}''^2} \quad (12)$$

"Manual calculation of the uncertainty"

dq\_flux\_1\_TC\_1=dT\*k\_s/L\_2

"uncertainty in heat flux 1 due to TC\_1"

dq\_flux\_1\_TC\_2=dT\*k\_s/L\_2

"uncertainty in heat flux 1 due to TC\_2"

dq\_flux\_1\_k\_s=(TC\_1-TC\_2)\*dk\_s/L\_2

"uncertainty in heat flux 1 due to k\_s"

dq\_flux\_1\_L\_2=(TC\_1-TC\_2)\*k\_s\*dL/L\_2^2

"uncertainty in heat flux 1 due to L\_2"

dq\_flux\_1=sqrt(dq\_flux\_1\_TC\_1^2+dq\_flux\_1\_TC\_2^2+dq\_flux\_1\_k\_s^2+dq\_flux\_1\_L\_2^2)

"uncertainty in heat flux 1 measurement"

The total uncertainty in the heat flux is  $\delta \dot{q}_1'' = 81.0 \text{ W/m}^2$ .

e.) Verify that EES' uncertainty propagation function provides the same answer obtained in (d).

The uncertainty propagation capability of EES is accessed by selecting Uncertainty Propagation from the Calculate menu (Figure 3).

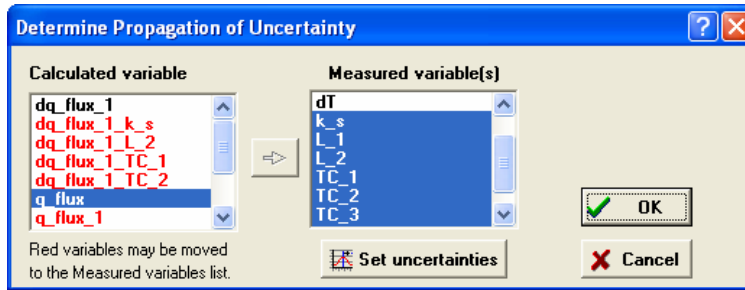

Figure 3: Uncertainty Propagation Window.

The calculated variable of interest is q\_flux\_1 and this should be selected from the Calculated variable list. The measured variables with uncertainty include the variables k\_s, L\_1, L\_2, TC\_1, TC\_2, TC\_3, and TC\_4; these should be selected from the Measured variable list. The uncertainty associated with these measured variables can be specified by selecting Set uncertainties (Figure 4).

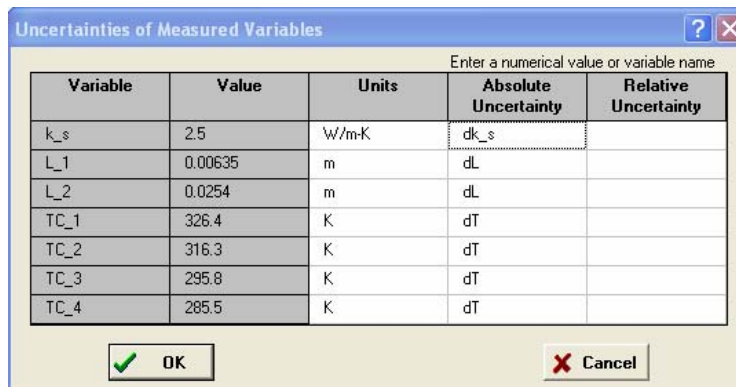

Figure 4: Uncertainties of Measured Variables Window.

The absolute uncertainties of each of the measured variables are assigned using the corresponding variable names (Figure 4). Select OK twice to see the results of the uncertainty propagation calculation (Figure 5).

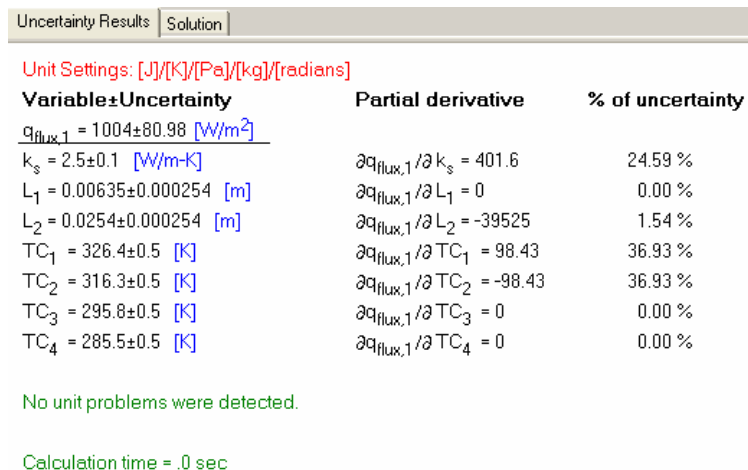
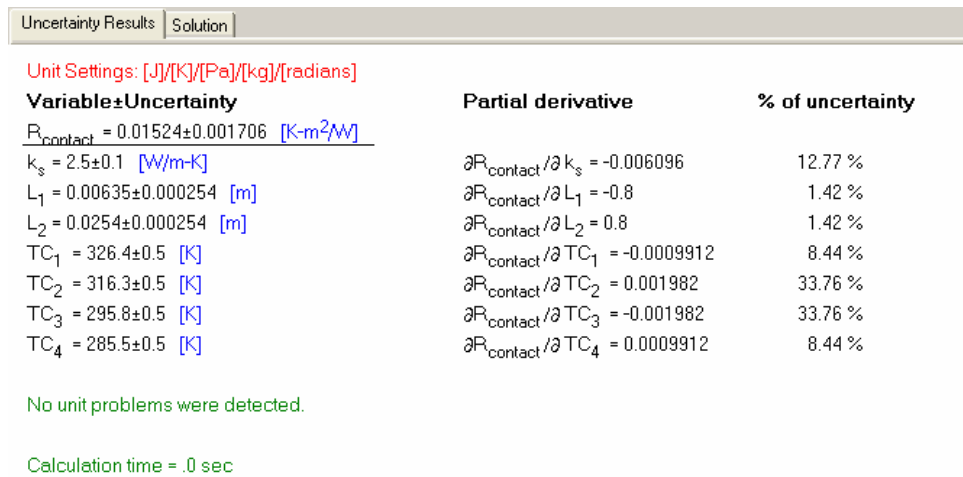

Figure 5: Uncertainty Results Window.

Notice that the heat flux uncertainty calculated by EES is also  $81.0 \text{ W/m}^2$ . The Uncertainty Results Window also delineates the sources of the uncertainty.

f.) Use EES' uncertainty propagation function to determine the uncertainty in the measured value of the contact resistance. What is the % uncertainty in your measurement?

Rather than the variable  $q_{\text{flux}_1}$ , the variable  $R_{\text{contact}}$  is selected in the Uncertainty of Measured Variables Window. The result of the calculation is shown in Figure 6.



**Figure 6: Uncertainty Results Window.**

The uncertainty in the contact resistance is  $0.0017 \text{ K-m}^2\text{/W}$  or 11%.

g.) Which of the fundamental measurements that are required by your test facility should be improved in order to improve your measurement of the contact resistance? That is, would you focus your attention on reducing  $\delta k_s$ ,  $\delta L$ , or  $\delta T$ ? Justify your answer.

Examination of Figure 6 suggests that the uncertainty in the contact resistance is due almost entirely to the temperature measurements. Therefore, I would focus my attention on reducing  $\delta T$ .

### Problem 1.2-8 (1-3 in text): Frozen Gutters

You have a problem with your house. Every spring at some point the snow immediately adjacent to your roof melts and runs along the roof line until it reaches the gutter. The water in the gutter is exposed to air at temperature less than  $0^{\circ}\text{C}$  and therefore freezes, blocking the gutter and causing water to run into your attic. The situation is shown in Figure P1.2-8.

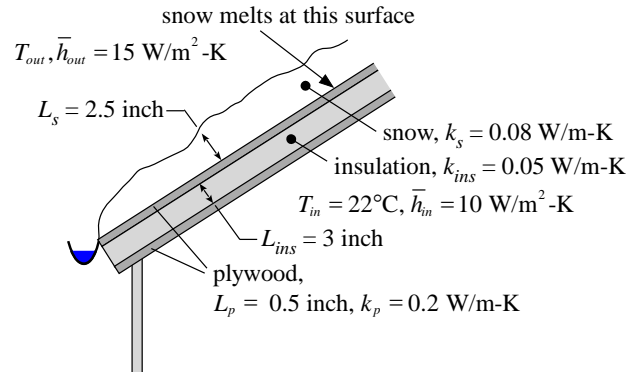

Figure P1.2-8: Roof of your house.

The air in the attic is at  $T_{in} = 22^{\circ}\text{C}$  and the heat transfer coefficient between the inside air and the inner surface of the roof is  $\bar{h}_{in} = 10 \text{ W/m}^2\text{-K}$ . The roof is composed of a  $L_{ins} = 3.0$  inch thick piece of insulation with conductivity  $k_{ins} = 0.05 \text{ W/m-K}$  that is sandwiched between two  $L_p = 0.5$  inch thick pieces of plywood with conductivity  $k_p = 0.2 \text{ W/m-K}$ . There is an  $L_s = 2.5$  inch thick layer of snow on the roof with conductivity  $k_s = 0.08 \text{ W/m-K}$ . The heat transfer coefficient between the outside air at temperature  $T_{out}$  and the surface of the snow is  $\bar{h}_{out} = 15 \text{ W/m}^2\text{-K}$ . Neglect radiation and contact resistances for part (a) of this problem.

a.) What is the range of outdoor air temperatures where you should be concerned that your gutters will become blocked by ice?

The input parameters are entered in EES and converted to base SI units (N, m, J, K) in order to eliminate any unit conversion errors; note that units should still be checked as you work the problem but that this is actually a check on the unit consistency of the equations.

#### "P1.2-8: Frozen Gutters"

\$UnitSystem SI MASS RAD PA K J

\$TABSTOPS 0.2 0.4 0.6 0.8 3.5 in

T\_in=converttemp(C,K,22)

"temperature in your attic"

L\_ins=3 [inch]\*convert(inch,m)

"insulation thickness"

L\_p=0.5 [inch]\*convert(inch,m)

"plywood thickness"

k\_ins=0.05 [W/m-K]

"insulation conductivity"

k\_p=0.2 [W/m-K]

"plywood conductivity"

k\_s=0.08 [W/m-K]

"snow conductivity"

L\_s=2.5 [inch]\*convert(inch,m)

"snow thickness"

h\_in=10 [W/m^2-K]

"heat transfer coefficient between attic air and inner surface of roof"

h\_out=15 [W/m^2-K]

"heat transfer coefficient between outside air and snow"

A=1 [m^2]

"per unit area"

The problem may be represented by the resistance network shown in Figure 2.

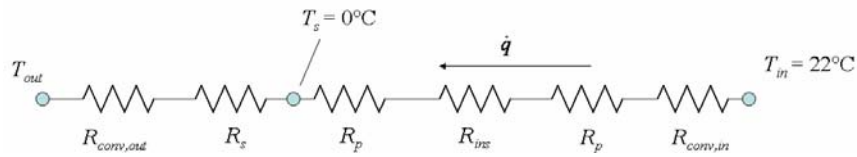

**Figure 2: Resistance network representing the roof of your house.**

The network includes resistances that correspond to convection with the inside and outside air:

$$R_{conv,out} = \frac{1}{h_{out} A} \quad (1)$$

$$R_{conv,in} = \frac{1}{h_{in} A} \quad (2)$$

where  $A$  is  $1 \text{ m}^2$  in order to accomplish the problem on a per unit area basis. There are also conduction resistances associated with the insulation, plywood and snow:

$$R_{ins} = \frac{L_{ins}}{k_{ins} A} \quad (3)$$

$$R_p = \frac{L_p}{k_p A} \quad (4)$$

$$R_s = \frac{L_s}{k_s A} \quad (5)$$

$R_{conv,out}=1/(h_{out}*A)$	"outer convection resistance"
$R_s=L_s/(k_s*A)$	"snow resistance"
$R_p=L_p/(k_p*A)$	"plywood resistance"
$R_{ins}=L_{ins}/(k_{ins}*A)$	"insulation resistance"
$R_{conv,in}=1/(h_{in}*A)$	"inner convection resistance"

Which leads to  $R_{conv,out} = 0.07 \text{ K/W}$ ,  $R_s = 0.79 \text{ K/W}$ ,  $R_p = 0.06 \text{ K/W}$ ,  $R_{ins} = 1.52 \text{ K/W}$  and  $R_{conv,in} = 0.10 \text{ K/W}$ . Therefore, the dominant effects for this problem are conduction through the insulation and the snow; the other effects (convection and the plywood conduction) are not terribly important since the largest resistances will dominate in a series network.

If the snow at the surface of the room is melting then the temperature at the connection between  $R_s$  and  $R_p$  must be  $T_s = 0^\circ\text{C}$  (see Figure 2). Therefore, the heat transferred through the roof ( $\dot{q}$  in Figure 2) must be:

$$\dot{q} = \frac{(T_{in} - T_s)}{R_{conv,in} + 2R_p + R_{ins}} \quad (6)$$

The temperature of the outside air must therefore be:

$$T_{out} = T_s - \dot{q}(R_s + R_{conv,out}) \quad (7)$$

```
T_s=converttemp(C,K,0)
"roof-to-snow interface temperature must be melting point of water"
q_dot=(T_in-T_s)/(R_conv_in+2*R_p+R_ins)
"heat transfer from the attic to the snow when melting point is reached"
T_out=T_s-q_dot*(R_s+R_conv_out)
"outside temperature required to reach melting point at roof surface"
T_out_C=converttemp(K,C,T_out) "outside temperature in C"
```

which leads to  $T_{out} = -10.8^\circ\text{C}$ . If the temperature is below this then the roof temperature will be below freezing and the snow will not melt. If the temperature is above  $0^\circ\text{C}$  then the water will not refreeze upon hitting the gutter. Therefore, the range of temperatures of concern are  $-10.8^\circ\text{C} < T_{out} < 0^\circ\text{C}$ .

b.) Would your answer change much if you considered radiation from the outside surface of the snow to surroundings at  $T_{out}$ ? Assume that the emissivity of snow is  $\epsilon_s = 0.82$ .

The modified resistance network that includes radiation is shown in Figure 3.

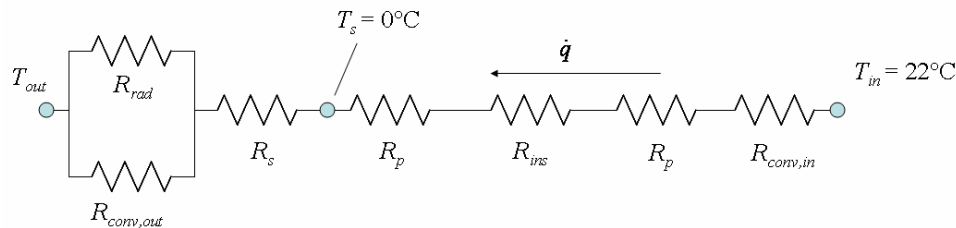

**Figure 3: Resistance network representing the roof of your house and including radiation.**

The additional resistance for radiation is in parallel with convection from the surface of the snow as heat is transferred from the surface by both mechanisms. The radiation resistance can be calculated approximately according to:

$$R_{rad} = \frac{1}{4\bar{T}^3 \epsilon_s \sigma A} \quad (8)$$

where  $\bar{T}$  is the average temperature of the surroundings and the snow surface. In order to get a quick idea of the magnitude of this resistance we can approximate  $\bar{T}$  with its largest possible value (which will result in the largest possible amount of radiation); the maximum temperature of the snow is  $0^\circ\text{C}$ :

```
e_s=0.82 [-] "emissivity of snow"
```

$$R_{rad} = 1 / (4 * T_s^3 * e_s * \sigma * A)$$

"radiation resistance"

which leads to  $R_{rad} = 0.26$  K/W. Notice that  $R_{rad}$  is much larger than  $R_{conv,out}$ ; the smallest resistance in a parallel combination dominates and therefore the impact of radiation will be minimal. Furthermore,  $R_{conv,out}$  is not even a very important resistance in the original series circuit shown in Figure 2.

### Problem 1.2-9: Computer Chip Cooling

Computer chips tend to work better if they are kept cold. You are examining the feasibility of maintaining the processor of a personal computer at the sub-ambient temperature of  $T_{chip} = 0^\circ\text{F}$ . Assume that the operation of the computer chip itself generates  $\dot{q}_{chip} = 10 \text{ W}$  of power. Model the processor unit as a box that is  $a = 2 \text{ inch} \times b = 6 \text{ inch} \times c = 4 \text{ inch}$ . Assume that all six sides of the box is exposed to air at  $T_{air} = 70^\circ\text{F}$  with a convection heat transfer coefficient of  $\bar{h} = 10 \text{ W/m}^2\text{-K}$ . The box experiences a radiation heat transfer with surroundings that are at  $T_{sur} = 70^\circ\text{F}$ . The emissivity of the processor surface is  $\varepsilon = 0.7$  and all six sides experience the radiation heat transfer. You are asked to size the refrigeration system required to maintain the temperature of the processor.

a.) What is the refrigeration load that your refrigeration system must be able to remove to maintain the processor at a steady-state temperature (W)?

The input parameters are entered in EES; notice that the units of each parameter are immediately converted into SI and the units of the associated variables are set (by you) in the Variable Information Window (Figure 2).

```

$UnitSystem SI MASS RAD PA K J
$TABSTOPS 0.2 0.4 0.6 0.8 3.5 in

"INPUTS"
T_chip = converttemp(F,K,0)
q_dot_chip = 10 [W]
a = 2 [inch]*convert(inch,m)
b = 6 [inch]*convert(inch,m)
c = 4 [inch]*convert(inch,m)
h = 10 [W/m^2-K]
T_air=converttemp(F,K,70)
T_sur=converttemp(F,K,70)
e = 0.7
    
```

"chip temperature"  
 "chip generation"  
 "dimensions of processor"  
  
 "heat transfer coefficient"  
 "air temperature"  
 "temperature of surroundings"  
 "emissivity of surface"

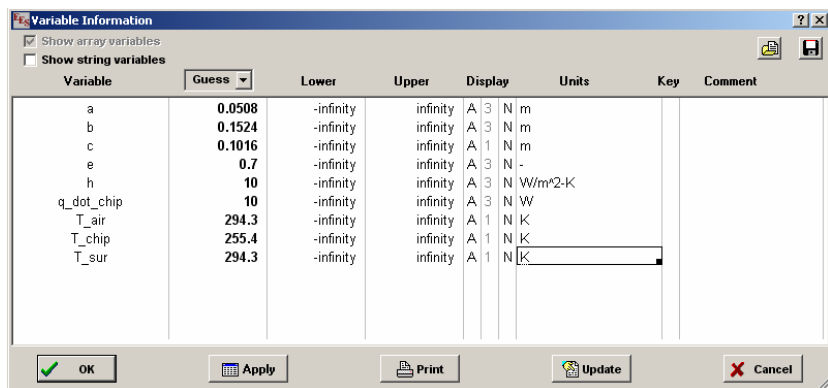

Figure 2: Variable Information window showing the units for each variable set.

A control volume encompasses just the processor and includes the internal generation from operating the chip ( $\dot{q}_{chip}$ ) as well as convection ( $\dot{q}_{conv}$ ) and radiation ( $\dot{q}_{rad}$ ) and the heat transfer removed by the refrigeration system ( $\dot{q}_{load}$ ). The energy balance is:

$$\dot{q}_{chip} + \dot{q}_{conv} + \dot{q}_{rad} = \dot{q}_{load} \quad (1)$$

The convection and radiation heat transfer rates may be evaluated using the associated rate equations:

$$\dot{q}_{conv} = h A_s (T_{air} - T_{chip}) \quad (2)$$

$$\dot{q}_{rad} = \sigma \varepsilon A_s (T_{sur}^4 - T_{chip}^4) \quad (3)$$

where  $\sigma$  is Stefan-Boltzmann's constant and  $A_s$  is the surface area of the processor:

$$A_s = 2(ab + bc + ac) \quad (4)$$

These equations are programmed in EES:

```
"part (a)"
A_s=2*(a*b+b*c+a*c)
q_dot_conv=h*A_s*(T_air-T_chip)
q_dot_rad=sigma#*e*A_s*(T_sur^4-T_chip^4)
q_dot_chip+q_dot_conv+q_dot_rad=q_dot_load
```

"surface area of processor"  
"convective heat transfer"  
"radiation heat transfer"  
"energy balance"

The units of the variables that have been added are also entered in the Variable Information window (Figure 3).

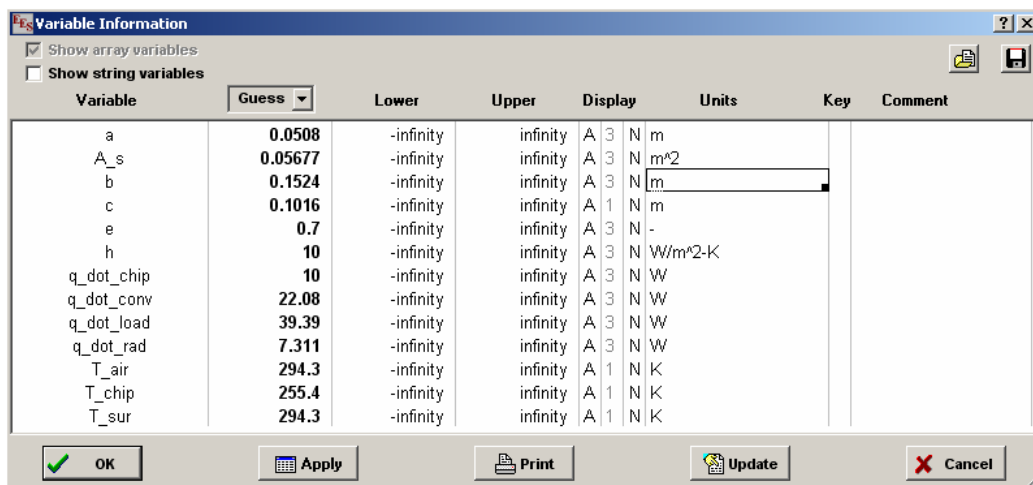

Figure 3: Variable Information window with additional units entered.

You can check that your solution is dimensionally consistent by selecting Check Units from the Calculate menu (Figure 4).

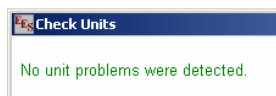

Figure 4: Check Units message

Solving the problem (Solve from the Calculate menu) will bring up the Solution Window (Figure 5) and shows that the refrigeration load is 39.4 W.

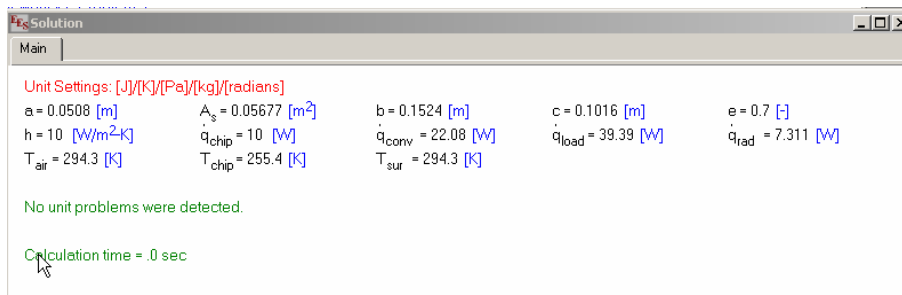

Figure 5: Solution Window

b.) If the coefficient of performance (COP) of the refrigeration system is nominally 3.5, then how much heat must be rejected to the ambient air (W)? Recall that COP is the ratio of the amount of refrigeration provided to the amount of input power required.

The definition of COP is:

$$\text{COP} = \frac{\dot{q}_{\text{load}}}{\dot{w}_{\text{ref}}} \quad (5)$$

which is programmed in EES:

```
"part (b)"
COP = 3.5                                "specified COP"
COP = q_dot_load/w_dot_ref               "refrigeration power"
```

and solved to show that the refrigeration power will be 11.3 W.

c.) If electricity costs 12¢/kW-hr, how much does it cost to run the refrigeration system for a year, assuming that the computer is never shut off.

The cost of electricity and time of operation are both converted to SI units and used to evaluate the cost per year.

```
"part (c)"
ecost = 12 [cents/kW-hr]*convert(cents/kW-hr,$/J)  "cost of electricity"
time=1 [year]*convert(year,s)                       "time of operation"
cost=time*ecost*w_dot_ref                            "cost of operating system for 1 year"
```

The cost of operating the system for 1 year is \$11.8.

### Problem 1.2-10: Insulation Conductivity Test

You have been contracted by ASHRAE (the American Society of Heating, Refrigeration, and Air-Conditioning Engineers) to measure the thermal conductivity of various, new materials for insulating pipes. Your contract specifies that you will measure the thermal conductivity to within 10%. Your initial design for the test setup is shown in Figure P1.2-10. The test facility consists of a pipe (with conductivity  $k_{pipe} = 120 \text{ W/m-K}$ ) with inner diameter,  $D_{i,pipe} = 6.0$  inch and thickness  $th_{pipe} = 0.5$  inch that carries a flow of chilled water,  $T_{water} = 10^\circ\text{C}$ . The heat transfer coefficient between the water and the internal surface of the pipe is  $\bar{h}_{water} = 300 \text{ W/m}^2\text{-K}$ . The pipe is covered by a  $th_{ins} = 2.0$  inch thick layer of the insulation (with conductivity  $k_{ins}$ ) that is being tested. Two thermocouples are embedded in the insulation, one connected to the outer surface ( $T_{ins,out}$ ) and the other to the inner surface ( $T_{ins,in}$ ). The insulation material is surrounded by a  $th_m = 3.0$  inch thick layer of a material with a well-known thermal conductivity,  $k_m = 2.0 \text{ W/m-K}$ . Two thermocouples are embedded in the material at its inner and outer surface ( $T_{m,in}$  and  $T_{m,out}$ , respectively). Finally, a band heater is wrapped around the outer surface of the material. Assume that the thickness of the band heater is negligibly small. The band heater provides  $\dot{q}_{band} = 3 \text{ kW/m}$ . The outer surface of the band heater is exposed to ambient air at  $T_{air} = 20^\circ\text{C}$  and has a heat transfer coefficient,  $\bar{h}_{air} = 10 \text{ W/m}^2\text{-K}$  and emissivity  $\varepsilon = 0.5$ . A contact resistance of  $R_c'' = 1 \times 10^{-4} \text{ m}^2\text{-K/W}$  is present at all 3 interfaces in the problem (i.e., between the pipe and the insulation, the insulation and the material, and the material and the band heater).

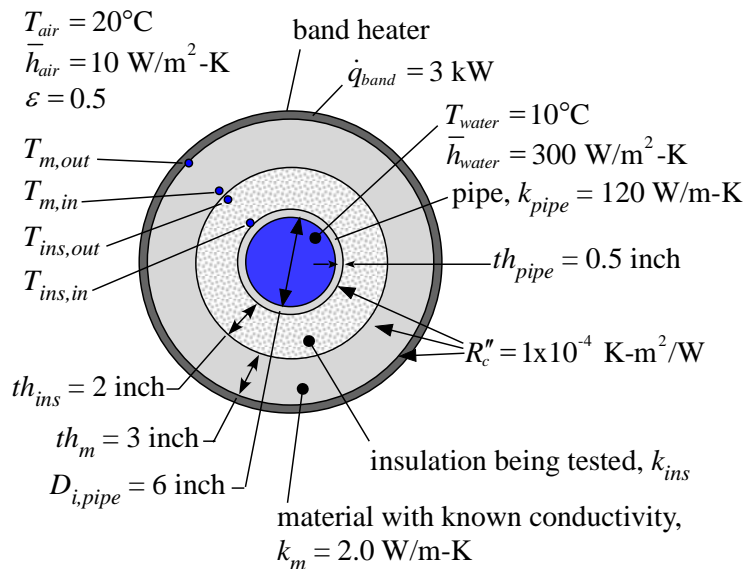

Figure P1.2-10: Test facility for measuring pipe insulation

You may assume that the problem is 1-D (i.e., there are no variations along the length or circumference of the pipe) and do the problem on a per unit length of pipe ( $L=1 \text{ m}$ ) basis.

- Draw a resistance network that represents the test facility. Clearly label each resistance and indicate what it represents. Be sure to indicate where in the network the heat input from the band heater will be applied and also the location of the thermocouples mentioned in the problem statement.

The resistance network is shown in Figure 2 and includes convection with the water and the air ( $R_{conv,w}$  and  $R_{air}$ ), conduction through the pipe, insulation, and material ( $R_{pipe}$ ,  $R_{cond,ins}$ , and  $R_{cond,m}$ ), contact resistances between the pipe and insulation ( $R_{c,1}$ ), the insulation and material ( $R_{c,2}$ ), and the material and the band heater ( $R_{c,3}$ ), and radiation ( $R_{rad}$ ).

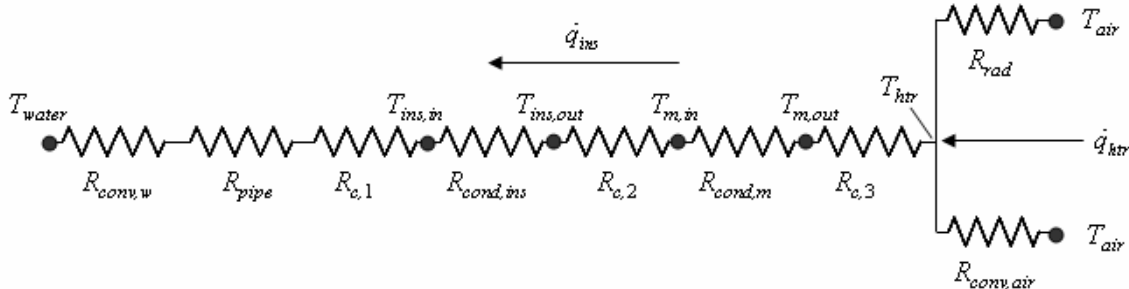

Figure 2: Resistance network representing the test facility.

- b.) If the coefficient of performance (COP) of the refrigeration system is nominally 3.5, then how much heat must be rejected to the ambient air (W)? Recall that COP is the ratio of the amount of refrigeration provided to the amount of input power required.

The known information is entered in EES:

```
$UnitSystem SI MASS RAD PA K J
$TABSTOPS 0.2 0.4 0.6 0.8 3.5 in
```

"Inputs"

```
k_pipe=120 [W/m-K]           "pipe conductivity"
D_i_pipe=6.0 [inch]*convert(inch,m) "pipe inner diameter"
th_pipe=0.5 [inch]*convert(inch,m) "pipe thickness"
T_water=converttemp(C,K,10 [C])    "water temperature"
h_water=300 [W/m^2-K]             "water to pipe heat transfer coefficient"
th_ins=2.0 [inch]*convert(inch,m)  "insulation thickness"
k_m=2.0 [W/m-K]                  "material thermal conductivity"
th_m=3.0 [inch]*convert(inch,m)    "material thickness"
T_air=converttemp(C,K,20 [C])     "air temperature"
h_air=10 [W/m^2-K]               "air to heater heat transfer coefficient"
e=0.5 [-]                        "emissivity of band heater surface"
R``_c=1e-4 [m^2-K/W]             "contact resistance"
L=1 [m]                           "length of pipe"
q_dot_htr=3 [kW]*convert(kW,W)    "heater power"
k_ins=1.0 [W/m-K]                 "insulation conductivity"
```

The values of the convection resistances are computed:

$$R_{conv,w} = \frac{1}{h_{water} \pi L D_{i,pipe}} \quad (1)$$

$$R_{conv,air} = \frac{1}{h_{air} \pi L (D_{i,pipe} + 2th_{pipe} + 2th_{ins} + 2th_m)} \quad (2)$$

$R_{conv,w} = 1/(h_{water} \cdot \pi \cdot L \cdot D_{i,pipe})$	"pipe-to-water convection"
$R_{conv,air} = 1/(h_{air} \cdot \pi \cdot L \cdot (D_{i,pipe} + 2 \cdot th_{pipe} + 2 \cdot th_{ins} + 2 \cdot th_m))$	"heater to air convection"

The conduction resistances are calculated according to:

$$R_{pipe} = \frac{\ln\left(\frac{D_{i,pipe} + 2th_{pipe}}{D_{i,pipe}}\right)}{2\pi L k_{pipe}} \quad (3)$$

$$R_{cond,ins} = \frac{\ln\left(\frac{D_{i,pipe} + 2th_{pipe} + 2th_{ins}}{D_{i,pipe} + 2th_{pipe}}\right)}{2\pi L k_{ins}} \quad (4)$$

$$R_{cond,m} = \frac{\ln\left(\frac{D_{i,pipe} + 2th_{pipe} + 2th_{ins} + 2th_m}{D_{i,pipe} + 2th_{pipe} + 2th_{ins}}\right)}{2\pi L k_m} \quad (5)$$

$R_{pipe} = \ln((D_{i,pipe}/2 + th_{pipe})/(D_{i,pipe}/2))/(2 \cdot \pi \cdot L \cdot k_{pipe})$	"pipe conduction resistance"
$R_{cond,ins} = \ln((D_{i,pipe}/2 + th_{pipe} + th_{ins})/(D_{i,pipe}/2 + th_{pipe}))/ (2 \cdot \pi \cdot L \cdot k_{ins})$	"insulation conduction resistance"
$R_{cond,m} = \ln((D_{i,pipe}/2 + th_{pipe} + th_{ins} + th_m)/(D_{i,pipe}/2 + th_{pipe} + th_{ins}))/ (2 \cdot \pi \cdot L \cdot k_m)$	"material conduction resistance"

The contact resistances are calculated according to:

$$R_{c,1} = \frac{R_c''}{\pi L (D_{i,pipe} + 2th_{pipe})} \quad (6)$$

$$R_{c,2} = \frac{R_c''}{\pi L (D_{i,pipe} + 2th_{pipe} + 2th_{ins})} \quad (7)$$

$$R_{c,3} = \frac{R_c''}{\pi L (D_{i,pipe} + 2th_{pipe} + 2th_{ins} + 2th_m)} \quad (8)$$

$R_{c,1} = R_c'' / (\pi \cdot (D_{i,pipe} + 2 \cdot th_{pipe}) \cdot L)$	"pipe-to-insulation contact resistance"
$R_{c,2} = R_c'' / (\pi \cdot (D_{i,pipe} + 2 \cdot th_{pipe} + 2 \cdot th_{ins}) \cdot L)$	"insulation-to-material contact resistance"
$R_{c,3} = R_c'' / (\pi \cdot (D_{i,pipe} + 2 \cdot th_{pipe} + 2 \cdot th_{ins} + 2 \cdot th_m) \cdot L)$	"material-to-heater contact resistance"

Finally, the radiation resistance is calculated according to:

$$R_{rad} = \frac{1}{\pi L (D_{i,pipe} + 2th_{pipe} + 2th_{ins} + 2th_m) \sigma \varepsilon (T_{htr}^2 + T_{air}^2) (T_{htr} + T_{air})} \quad (9)$$

but  $T_{htr}$  is not known in Eq. (9); therefore, a guess value of  $T_{htr}$  must be used to allow the calculation of the resistance. This guess value will be removed once a solution is obtained. A reasonable guess value for the heater temperature is something higher than the ambient temperature.

```
T_htr_g=500 [K]
    "this is a guess for the heater temperature - it allows me to calculate the radiation resistance"
    "this guess will be removed to complete the solution"
R_rad=1/(pi*(D_i_pipe+2*th_pipe+2*th_ins+2*th_m)*L*sigma#*e*(T_htr_g^2+T_air^2)*(T_htr_g+T_air))
    "radiation resistance"
```

The heat transferred to the heater must either pass inwards to the water or outwards to the ambient air.

$$\dot{q}_{htr} = \frac{(T_{htr} - T_{water})}{R_{conv,w} + R_{pipe} + R_{c,1} + R_{cond,ins} + R_{c,2} + R_{cond,m} + R_{c,3}} + \frac{(T_{htr} - T_{air})}{\left( \frac{1}{R_{conv,air}} + \frac{1}{R_{rad}} \right)^{-1}} \quad (10)$$

```
q_dot_htr=(T_htr-T_water)/(R_conv_w+R_pipe+R_c_1+R_cond_ins+R_c_2+R_cond_m+R_c_3)+(T_htr-
T_air)/((1/R_conv_air+1/R_rad)^(-1))    "heater power"
```

The calculated and guessed values of  $T_{htr}$  will not be the same (unless you are very lucky); update the guess values for the calculation (select Update Guesses from the Calculate menu) and then specify that  $T_{htr\_g}$  must equal  $T_{htr}$ . You will need to comment the assignment of  $T_{htr\_g}$  to avoid over-specifying the problem.

```
{T_htr_g=500 [K]    "this is a guess for the heater
temperature - it allows me to calculate the radiation resistance"
    "this guess will be removed to complete the solution"}
T_htr=T_htr_g
```

The heater temperature is found to be 394.6 K (about 120°C which is too hot to touch). The heat transferred through the insulation is:

$$\dot{q}_{ins} = \frac{(T_{htr} - T_{water})}{R_{conv,w} + R_{pipe} + R_{c,1} + R_{cond,ins} + R_{c,2} + R_{cond,m} + R_{c,3}} \quad (11)$$

```
q_dot_ins=(T_htr-T_water)/(R_conv_w+R_pipe+R_c_1+R_cond_ins+R_c_2+R_cond_m+R_c_3)
    "heat transferred through insulation"
```

which leads to  $\dot{q}_{ins} = 976.3$  W (most of the heat is transferred to the surrounding air).

When the test facility is operated, the heater power is not measured nor are the contact resistances, emissivity, or heat transfer coefficients known with any precision. Also, the insulation thermal conductivity is not known, but rather must be calculated from the measured temperatures. The heat transferred through the material with known thermal conductivity is the same as the heat transferred through the insulation that is being measured. Therefore:

$$\dot{q}_{ins} = \frac{T_{m,out} - T_{m,in}}{R_{cond,m}} = \frac{T_{ins,out} - T_{ins,in}}{R_{cond,ins}} \quad (12)$$

and so the resistance of the insulation can be calculated based on the ratio of the temperature differences:

$$R_{cond,ins} = \frac{(T_{ins,out} - T_{ins,in})}{(T_{m,out} - T_{m,in})} R_{cond,m} \quad (13)$$

Equation (13) indicates that the test facility relies on accurately measuring the temperature differences across the insulation and the temperature difference across the material.

c.) Using your model, predict the temperature difference across the insulation ( $\Delta T_{ins} = T_{ins,out} - T_{ins,in}$ ) and the material ( $\Delta T_m = T_{m,out} - T_{m,in}$ ).

Using Eq. (12), the two temperature differences are:

$$\Delta T_{ins} = \dot{q}_{ins} R_{cond,ins} \quad (14)$$

$$\Delta T_m = \dot{q}_{ins} R_{cond,m} \quad (15)$$

DeltaT_ins=q_dot_ins*R_cond_ins	"insulation temperature difference"
DeltaT_m=q_dot_ins*R_cond_m	"material temperature difference"

which leads to  $\Delta T_{ins} = 70.2$  K and  $\Delta T_m = 33.8$  K.

d.) Prepare a plot showing  $\Delta T_m$  as a function of the material thickness ( $th_m$ ) for thicknesses ranging from 5.0 mm to 50 cm. Explain the shape of your plot.

The plot requested by the problem statement is generated using a parametric table that include the variables  $th_m$  and  $\Delta T_m$ . The result is shown in Figure 3.

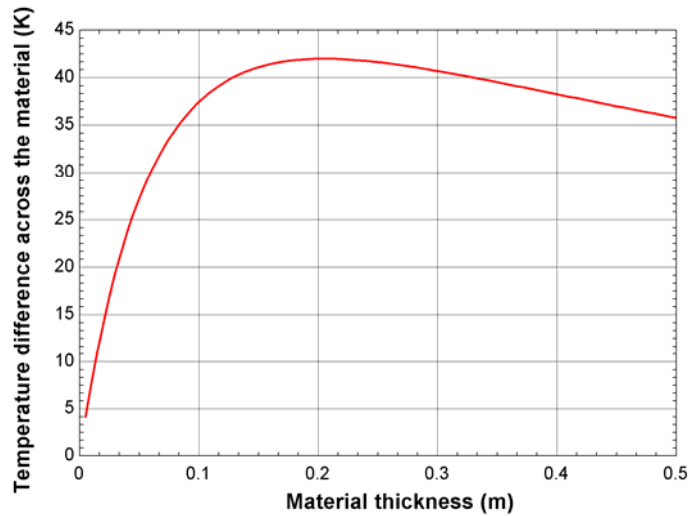

**Figure 3: Temperature difference across the material as a function of the material thickness.**

Notice that at low  $th_m$  the value of  $\Delta T_m$  is small because the resistance of the material is small. At high values of  $th_m$  the resistance of the material is large but the heat transferred through the material becomes small (more of the energy is transferred to the air) and so the value of  $\Delta T_m$  begins to decrease.

e.) Based on your plot from part (d), what is a reasonable value for  $th_m$ ? Remember that you need to measure the temperature difference and therefore you would like it to be large.

A value of  $th_m$  around 10 cm provides a large value of  $\Delta T_m$ ; further increases are probably not justified. A similar plot and design point could be obtained for  $\Delta T_{ins}$  by varying  $th_{ins}$ .