

GLOBAL  
EDITION



# Structural Analysis

Tenth Edition in SI Units

R. C. Hibbeler



# STRUCTURAL ANALYSIS

TENTH EDITION IN SI UNITS

---

**R. C. HIBBELER**

*SI Conversion by*

**Kai Beng Yap**

*With Additional SI Contributions by*

**Farid Abed**



Senior Vice President Courseware Portfolio Management:  
*Marcia J. Horton*  
Director, Portfolio Management: Engineering, Computer  
Science & Global Editions: *Julian Partridge*  
Specialist Portfolio Management: *Norrin Dias*  
Portfolio Management Assistant: *Michelle Bayman*  
Field Marketing Manager: *Demetrius Hall*  
Product Marketing Manager: *Yvonne Vannatta*  
Marketing Assistant: *Jon Bryant*  
Managing Producer, ECS and Math: *Scott Disanno*  
Content Producer: *Sandra L. Rodriguez*

Operations Specialist: *Maura Zaldivar-Garcia*  
Senior Manufacturing Controller, Global Edition:  
*Caterina Pellegrino*  
Project Manager: *Rose Kernan*  
Editor, Global Edition: *Subhasree Patra*  
Manager, Rights and Permissions: *Ben Ferrini*  
Composition: *Integra Software Services, Inc.*  
Printer/Binder: *Vivar*  
Cover Designer: *Lumina Datamatics Ltd.*  
Cover Photo: *Petruk Viktor/Shutterstock*

---

Pearson Education Limited  
KAO Two  
KAO Park  
Harlow  
CM17 9NA  
United Kingdom

and Associated Companies throughout the world

Visit us on the World Wide Web at:  
[www.pearsonglobaleditions.com](http://www.pearsonglobaleditions.com)

© 2020 by R. C. Hibbeler. Published by Pearson Education, Inc. or its affiliates.

The rights of R. C. Hibbeler to be identified as the author of this work have been asserted by him in accordance with the Copyright, Designs and Patents Act 1988.

*Authorized adaptation from the United States edition, entitled Structural Analysis, ISBN 978-0-13-461067-2, by R. C. Hibbeler, published by Pearson Education, Inc., © 2018, 2015, 2012, 2000.*

All rights reserved. No part of this publication may be reproduced, stored in a retrieval system, or transmitted in any form or by any means, electronic, mechanical, photocopying, recording or otherwise, without either the prior written permission of the publisher or a license permitting restricted copying in the United Kingdom issued by the Copyright Licensing Agency Ltd, Saffron House, 6–10 Kirby Street, London EC1N 8TS.

Many of the designations by manufacturers and seller to distinguish their products are claimed as trademarks. Where those designations appear in this book, and the publisher was aware of a trademark claim, the designations have been printed in initial caps or all caps. The author and publisher of this book have used their best efforts in preparing this book. These efforts include the development, research, and testing of theories and programs to determine their effectiveness.

The author and publisher make no warranty of any kind, expressed or implied, with regard to these programs or the documentation contained in this book. The author and publisher shall not be liable in any event for incidental or consequential damages with, or arising out of, the furnishing, performance, or use of these programs.

#### **British Library Cataloguing-in-Publication Data**

A catalogue record for this book is available from the British Library.

1 19

ISBN 10: 1-292-24713-4

ISBN 13: 978-1-292-24713-7

Printed in Malaysia (CTP-VVP)



## ***To The Student***

With the hope that this work will stimulate  
an interest in Structural Analysis  
and provide an acceptable guide to its understanding.

*This page intentionally left blank*



# PREFACE

---

This book is intended to provide the student with a clear and thorough presentation of the theory and application of structural analysis as it applies to trusses, beams, and frames. Emphasis is placed on developing the student's ability to both model and analyze a structure and to provide realistic applications encountered in professional practice.

For many years now, engineers have been using computer programs based on matrix methods to analyze structures. Although these methods are most efficient for a structural analysis, it is the author's opinion that students taking a first course in this subject should also be well versed in some of the more important classical methods of structural analysis. By applying these methods it is possible to obtain a better understanding of how loads are transmitted through a structure, and how the structure will deform under load. These skills are also important for selecting a model of the structure that provides an accurate description of its behaviour. Finally the classical methods can be used to check computer results, rather than simply relying on the generated output.

**New to this Edition.** Several important new features are included in this edition.

**Rewriting of Text Material.** Concepts have been clarified and further expanded.

**New Material Added Throughout.** Chapters have been expanded with the addition of new material, including a discussion of catenary cables and further clarification for drawing moment and deflection diagrams for beams and frames.

**New Problems.** There are many new problems that have been added to this edition, along with the addition of preliminary problems.

**Chapter Rearrangement.** The chapter on approximate analysis has been placed later in the book, after the coverage of statically indeterminate structures.

**Structural Modeling.** The importance of being able to model a structure for use as input for a computer analysis is discussed throughout the book, and more specifically in Chapter 17.

## ORGANIZATION AND APPROACH

The contents of each chapter are arranged into sections with specific topics categorized by title headings. Discussions relevant to a particular theory are succinct, yet thorough. In most cases, this is followed by a "procedure

for analysis” guide, which provides the student with a summary of the important concepts and a systematic approach for applying the theory. The example problems are solved using this outlined method in order to clarify its numerical application. Problems are given at the end of each chapter, and are arranged to cover the material in sequential order. Moreover, for any topic they are arranged in approximate order of increasing difficulty.

## HALLMARK ELEMENTS

- **Photographs.** Many photographs are used throughout the book to explain how the principles of structural analysis apply to real-world situations.
- **Problems.** Most of the problems in the book depict realistic situations encountered in practice. It is hoped that this realism will both stimulate the student’s interest in structural analysis and develop the skill to reduce any such problem from its physical description to a model or symbolic representation to which the appropriate theory can be applied. All problems are in SI units. The intent has been to provide problems that test the student’s ability to apply the theory, keeping in mind that more complicated problems requiring tedious calculations can be relegated to computer analysis.
- **Answers to Selected Problems.** The answers to all but every fourth problem, indicated by an asterisk in the text, are listed in the back of the book. Extra care has been taken in the presentation and solution of the problems, and all the problem sets have been reviewed and the solutions checked and rechecked to ensure both their clarity and numerical accuracy.
- **Example Problems.** All the example problems are presented in a concise manner and in a style that is easy to understand.
- **Illustrations.** Throughout the book, an increase in two-color art has been added, including many photorealistic illustrations that provide a three-dimensional view for better understanding.
- **Triple Accuracy Checking.** This edition has undergone rigorous accuracy checking and proofing of pages. Besides the author’s review of all the pages and problems, a recheck was provided by K. Norlin of the Bittner Development Group, the Competentum team, specifically Pavel Kolmakov and Daria Zamiusskaya, K.B. Yap, and J.H. Lee.
- **Preliminary and Fundamental Problems.** These problem sets are selectively located at the end of many chapters. They offer students simple applications of the concepts and, therefore, provide them with the chance to develop their problem-solving skills before attempting to solve any of the standard problems that follow. You might consider these problems as

extended examples since they *all have solutions and answers* that are given in the back of the book. Additionally, the fundamental problems offer students an excellent means of studying for exams, and they can be used at a later time to prepare for various engineering exams.

## CONTENTS

This book is divided into three parts. The first part covers the analysis for statically determinate structures. Chapter 1 provides a discussion of the various types of structural forms and loads. Chapter 2 discusses the determination of forces at the supports and connections of statically determinate beams and frames. The analysis of various types of statically determinate trusses is given in Chapter 3, and shear and bending-moment functions and diagrams for beams and frames are presented in Chapter 4. In Chapter 5, the analysis of simple cable and arch systems is presented, and in Chapter 6 influence lines for beams, girders, and trusses are discussed.

In the second part of the book, the analysis of statically indeterminate structures is considered. Geometrical methods for calculating deflections are discussed in Chapter 7. Energy methods for finding deflections are covered in Chapter 8. Chapter 9 covers the analysis of statically indeterminate structures using the force method of analysis, in addition to a discussion of influence lines for beams. Then the displacement methods consisting of the slope-deflection method in Chapter 10 and moment distribution in Chapter 11 are discussed. Using these methods, beams and frames having nonprismatic members are considered in Chapter 12. Finally, Chapter 13 discusses several common techniques that are used for an approximate analysis of a statically indeterminate structure.

The third part of the book treats the matrix analysis of structures using the stiffness method. Trusses are discussed in Chapter 14, beams in Chapter 15, and frames in Chapter 16. Finally, Chapter 17 provides some basic ideas as to how to model a structure, and for using available computer software for performing a structural analysis. A review of matrix algebra is given in Appendix A.

## RESOURCES FOR INSTRUCTORS

- **Mastering Engineering.** This online Tutorial Homework program allows you to integrate dynamic homework with automatic grading. Mastering Engineering allows you to easily track the performance of your entire class on an assignment-by-assignment basis, or the detailed work of an individual student.
- **Instructor's Solutions Manual.** An instructor's solutions manual was prepared by the author. The manual was also checked as part of the Triple Accuracy Checking program. You can find the Solutions Manual on the Instructor Resource Center website [www.pearsonglobaleditions.com](http://www.pearsonglobaleditions.com).

- **Presentation Resources.** All art from the text is available in PowerPoint slide and JPEG format. These files are available for download from the Instructor Resource Center at [www.pearsonglobaleditions.com](http://www.pearsonglobaleditions.com). If you are in need of a login and password for this site, please contact your local Pearson representative.
- **Video Solutions.** Video solutions offer step-by-step solution walkthroughs of representative homework problems from each chapter of the text. Make efficient use of class time and office hours by showing students the complete and concise problem solving approaches that they can access anytime and view at their own pace. The videos are designed to be a flexible resource to be used however each instructor and student prefers. A valuable tutorial resource, the videos are also helpful for student self-evaluation as students can pause the videos to check their understanding and work alongside the video. Access the videos at [www.pearsonglobaleditions.com](http://www.pearsonglobaleditions.com) and follow the links for the *Structural Analysis* text.

## RESOURCES FOR STUDENTS

- **Mastering Engineering.** Tutorial homework problems emulate the instructor's office-hour environment.
- **Companion Website.** The companion website, located at [www.pearsonglobaleditions.com](http://www.pearsonglobaleditions.com), includes opportunities for practice and review including video solutions, which provide complete, step-by-step solution walkthroughs of representative homework problems from each chapter. The videos offer:
  - **Fully-worked Solutions**—Showing every step of representative homework problems, to help students make vital connections between concepts.
  - **Self-paced Instruction**—Students can navigate each problem and select, play, rewind, fast-forward, stop, and jump-to-sections within each problem's solution.
  - **24/7 Access**—Help whenever students need it.

## ACKNOWLEDGMENTS

Through the years, over one hundred of my colleagues in the teaching profession and many of my students have made valuable suggestions that have helped in the development of this book, and I would like to hereby acknowledge all of their comments. I personally would like to thank the reviewers contracted by my editor for this new edition, namely:

S. Chao, *University of Texas, Arlington*  
P. Gardoni, *University of Illinois at Urbana-Champaign*  
J. Marshall, *Auburn University*  
V. May, *Dartmouth College*  
T. Miller, *Oregon State University*  
H. Najm, *Rutgers University*  
T. Ross, *University of New Mexico*  
S. Vukazich, *San Jose State University*

Also, the constructive comments from Kai Beng Yap, a practicing engineer, and Jun Hwa Lee are greatly appreciated. Finally, I would like to acknowledge the support I received from my wife Conny, who has always been very helpful in preparing the manuscript for publication.

I would greatly appreciate hearing from you if at any time you have any comments or suggestions regarding the contents of this edition.

Russell Charles Hibbeler  
*hibbeler@bellsouth.net*

## GLOBAL EDITION

The publishers would like to thank the following for their contribution to the Global Edition:

### **Contributor for the Ninth and Tenth Editions in SI Units**

**Kai Beng Yap** is currently a registered professional engineer who works in Malaysia. He has BS and MS degrees in civil engineering from the University of Louisiana, Lafayette, Louisiana; and has done further graduate work at Virginia Tech in Blacksburg, Virginia. He has taught at the University of Louisiana and worked as an engineering consultant in the areas of structural analysis and design, and the associated infrastructure.

### **Co-contributor for the Tenth Edition in SI Units**

**Farid Abed** is currently a faculty member in the Department of Civil Engineering at the American University of Sharjah, where he teaches undergraduate courses in structural analysis and mechanics and graduate courses in advanced structural analysis and computational mechanics to civil engineering students. He received his PhD degree in civil engineering from Louisiana State University, and his research interests include computational solid and structural mechanics, advanced mechanics of materials, nonlinear finite elements, and damage mechanics.

### **Reviewers for the Tenth Edition in SI Units**

**Farid Abed**, *American University of Sharjah*  
**Imad Abou-Hayt**, *University of Aalborg*  
**Samit Ray Chaudhuri**, *Indian Institute of Technology Kanpur*  
**Kevin Kuang Sze Chiang**, *National University of Singapore*

# your work...

PART B

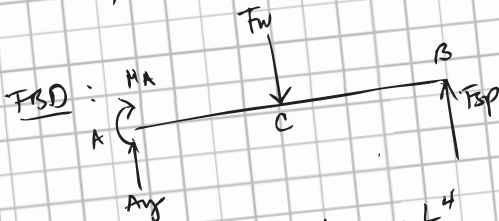
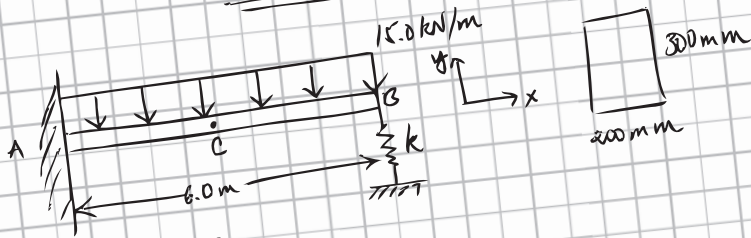

$$V_B = V_B' - V_B'' \quad V_B' = w \frac{L^4}{8EI} \quad V_B'' = \frac{-PL^3}{3EI}$$

$$F_{BP} = kV_B \Rightarrow F_{BP} = \frac{3wL^4}{8(3EI + kL^3)}$$

$$I = \frac{1}{12} (0.3\text{m})(0.2\text{m})^3 = 2 \times 10^{-4} \text{ m}^4$$

$$F_{BP} = \frac{3}{8} \left( \frac{15 \text{ kN}}{\text{m}} \right) (6.0\text{m})^4 \frac{15.0 \text{ kN/m}}{3(20067\text{N})(2 \times 10^{-4} \text{ m}^4) + \left( \frac{15.0 \text{ kN}}{\text{m}} \right) (6.0\text{m})^3}$$

$$F_{BP} = 15.99 \text{ kN}$$



# your answer **specific feedback**

## Part B - Spring force at B

Using the method of superposition, determine the force  $F_{sp}$  that the spring at B exerts on the bar. Assume that this force acts in the positive y direction.

Express your answer in kN to three significant figures.

kN

**Submit** [Hints](#) [My Answers](#) [Give Up](#) [Review Part](#)

**Incorrect; Try Again**

Review the equation used for the moment of inertia of the cross section.

# CONTENTS

## **1** Types of Structures and Loads **18**

- 1.1 Introduction 19
- 1.2 Classification of Structures 20
- 1.3 Loads 25
- 1.4 Structural Design 44  
Problems 45  
Chapter Review 49

## **2** Analysis of Statically Determinate Structures **50**

- 2.1 Idealized Structure 51
- 2.2 Load Path 64
- 2.3 Principle of Superposition 65
- 2.4 Equations of Equilibrium 66
- 2.5 Determinacy and Stability 67
- 2.6 Application of the Equations of Equilibrium 74  
Fundamental Problems 84  
Problems 86  
Project Problem 95  
Chapter Review 96

## **3** Analysis of Statically Determinate Trusses **98**

- 3.1 Common Types of Trusses 99
- 3.2 Classification of Coplanar Trusses 105
- 3.3 The Method of Joints 112
- 3.4 Zero-Force Members 116
- 3.5 The Method of Sections 118
- 3.6 Compound Trusses 124
- 3.7 Complex Trusses 128
- 3.8 Space Trusses 132  
Fundamental Problems 139  
Problems 141  
Project Problem 151  
Chapter Review 152

## **4** Internal Loadings Developed in Structural Members **154**

- 4.1 Internal Loadings at a Specified Point 155
- 4.2 Shear and Moment Functions 161
- 4.3 Shear and Moment Diagrams for a Beam 166
- 4.4 Shear and Moment Diagrams for a Frame 176
- 4.5 Moment Diagrams Constructed by the Method of Superposition 181  
Preliminary Problems 188  
Fundamental Problems 190  
Problems 194  
Project Problems 204  
Chapter Review 205

## **5** Cables and Arches **206**

- 5.1 Cables 207
- 5.2 Cable Subjected to Concentrated Loads 208
- 5.3 Cable Subjected to a Uniform Distributed Load 210
- 5.4 Cable Subjected to Its Own Weight 216
- 5.5 Arches 220
- 5.6 Three-Hinged Arch 221  
Problems 227  
Chapter Review 235

## 6 Influence Lines for Statically Determinate Structures 236

- 6.1 Influence Lines 237
- 6.2 Influence Lines for Beams 245
- 6.3 Qualitative Influence Lines 248
- 6.4 Influence Lines for Floor Girders 256
- 6.5 Influence Lines for Trusses 260
- 6.6 Maximum Influence at a Point due to a Series of Concentrated Loads 264
- 6.7 Absolute Maximum Shear and Moment 274
  - Fundamental Problems 279
  - Problems 280
  - Project Problems 291
  - Chapter Review 292

## 7 Deflections 294

- 7.1 Deflection Diagrams and the Elastic Curve 295
- 7.2 Elastic-Beam Theory 301
- 7.3 The Double Integration Method 303
- 7.4 Moment-Area Theorems 310
- 7.5 Conjugate-Beam Method 320
  - Preliminary Problems 328
  - Fundamental Problems 330
  - Problems 332
  - Chapter Review 336

## 8 Deflections Using Energy Methods 338

- 8.1 External Work and Strain Energy 339
- 8.2 Principle of Work and Energy 343
- 8.3 Principle of Virtual Work 344
- 8.4 Method of Virtual Work: Trusses 346
- 8.5 Castigliano's Theorem 353
- 8.6 Castigliano's Theorem for Trusses 354
- 8.7 Method of Virtual Work: Beams and Frames 360
- 8.8 Virtual Strain Energy Caused by Axial Load, Shear, Torsion, and Temperature 371
- 8.9 Castigliano's Theorem for Beams and Frames 377
  - Fundamental Problems 383
  - Problems 385
  - Chapter Review 392

## 9 Analysis of Statically Indeterminate Structures by the Force Method 394

- 9.1 Statically Indeterminate Structures 395
- 9.2 Force Method of Analysis: General Procedure 399
- 9.3 Maxwell's Theorem of Reciprocal Displacements 403
- 9.4 Force Method of Analysis: Beams 404
- 9.5 Force Method of Analysis: Frames 412
- 9.6 Force Method of Analysis: Trusses 416
- 9.7 Composite Structures 419
- 9.8 Symmetric Structures 421
- 9.9 Influence Lines for Statically Indeterminate Beams 423
- 9.10 Qualitative Influence Lines for Frames 427
  - Fundamental Problems 434
  - Problems 435
  - Chapter Review 446

## 10 Displacement Method of Analysis: Slope-Deflection Equations 448

- 10.1 Displacement Method of Analysis: General Procedures 449
- 10.2 Slope-Deflection Equations 451
- 10.3 Analysis of Beams 457
- 10.4 Analysis of Frames: No Sidesway 465
- 10.5 Analysis of Frames: Sidesway 470
  - Problems 478
  - Project Problem 483
  - Chapter Review 483

## 11 Displacement Method of Analysis: Moment Distribution 484

- 11.1 General Principles and Definitions 485
- 11.2 Moment Distribution for Beams 489
- 11.3 Stiffness-Factor Modifications 498
- 11.4 Moment Distribution for Frames: No Sidesway 504
- 11.5 Moment Distribution for Frames: Sidesway 506
  - Problems 514
  - Chapter Review 519

## 12 Approximate Analysis of Statically Indeterminate Structures 520

- 12.1 Use of Approximate Methods 521
- 12.2 Trusses 522
- 12.3 Vertical Loads on Building Frames 526
- 12.4 Portal Frames and Trusses 529
- 12.5 Lateral Loads on Building Frames: Portal Method 534
- 12.6 Lateral Loads on Building Frames: Cantilever Method 540
  - Problems 546
  - Chapter Review 554

## 13 Beams and Frames Having Nonprismatic Members 556

- 13.1 Introduction 557
- 13.2 Loading Properties of Nonprismatic Members 558
- 13.3 Moment Distribution for Structures Having Nonprismatic Members 562
- 13.4 Slope-Deflection Equations for Nonprismatic Members 568
  - Problems 570
  - Chapter Review 571

## 14 Truss Analysis Using the Stiffness Method 572

- 14.1 Fundamentals of the Stiffness Method 573
- 14.2 Member Stiffness Matrix 576
- 14.3 Displacement and Force Transformation Matrices 577
- 14.4 Member Global Stiffness Matrix 580
- 14.5 Truss Stiffness Matrix 581
- 14.6 Application of the Stiffness Method for Truss Analysis 586
- 14.7 Nodal Coordinates 594
- 14.8 Trusses Having Thermal Changes and Fabrication Errors 598
- 14.9 Space-Truss Analysis 604
  - Problems 606
  - Chapter Review 607

## 15 Beam Analysis Using the Stiffness Method 608

- 15.1 Preliminary Remarks 609
- 15.2 Beam-Member Stiffness Matrix 611
- 15.3 Beam-Structure Stiffness Matrix 613
- 15.4 Application of the Stiffness Method for Beam Analysis 613
  - Problems 626

## **16** Plane Frame Analysis Using the Stiffness Method **628**

- 16.1 Frame-Member Stiffness Matrix 629
- 16.2 Displacement and Force Transformation Matrices 631
- 16.3 Frame-Member Global Stiffness Matrix 633
- 16.4 Application of the Stiffness Method for Frame Analysis 634  
Problems 643

## **17** Structural Modeling and Computer Analysis **646**

- 17.1 General Structural Modeling 647
- 17.2 Modeling a Structure and its Members 649
- 17.3 General Application of a Structural Analysis Computer Program 654  
Computer Problems 659  
Project Problems 661

## **Appendix**

**A** Matrix Algebra for Structural Analysis 664

**Preliminary and Fundamental Problem Solutions** 677

**Answers to Selected Problems** 705

**Index** 723

*This page intentionally left blank*

# STRUCTURAL ANALYSIS

# CHAPTER 1



@ Carlo Allegri/GettyImages

Severe wind loadings caused by a hurricane have caused noticeable damage to the windows of this high-rise building.

# TYPES OF STRUCTURES AND LOADS

## CHAPTER OBJECTIVES

---

- To introduce the basic types of structures.
  - To provide a brief explanation of the various types of loads that must be considered for an appropriate analysis and design.
- 

## 1.1 INTRODUCTION

In this book we will present many of the different ways engineers model and then determine the loadings and deflections of various types of structures. Important examples related to civil engineering include buildings, bridges, and towers; and in other branches of engineering, ship and aircraft frames, mechanical systems, and electrical supporting structures are important.

Throughout this book, a *structure* refers to any system of connected parts used to support a load. When designing a structure to serve a specified function for public use, the engineer must account for its safety, esthetics, and serviceability, while taking into consideration economic and environmental constraints. For any project this often requires several independent studies, using different structural forms, before a final judgment can be made as to which form is most appropriate. This design process is both creative and technical and requires a fundamental knowledge of material properties and the laws of mechanics which govern material response. Once a preliminary design of a structure is

proposed, the structure must then be *analyzed* to ensure that it has its required stiffness, strength, and stability. To do this, an idealization must be made as to how all members are supported and connected together. Then the loadings are determined from codes and local specifications. Finally, the forces in the members and their displacements are found using the theory of structural analysis, which is the subject matter of this book.

## 1.2 CLASSIFICATION OF STRUCTURES

It is important for a structural engineer to recognize the various types of elements composing a structure and to be able to classify structures as to their form and function. We will introduce some of these aspects now and discuss others throughout the book.

**Structural Elements.** Some of the more common elements from which structures are composed are as follows.

**Tie Rods.** Structural members that are subjected to a *tensile force* are often referred to as *tie rods* or *bracing struts*. These members are rather slender, and are often chosen from rods, bars, angles, or channels, Fig. 1-1.



Tie rods are used for cross bracing to stiffen the roof of a building to resist wind loads.

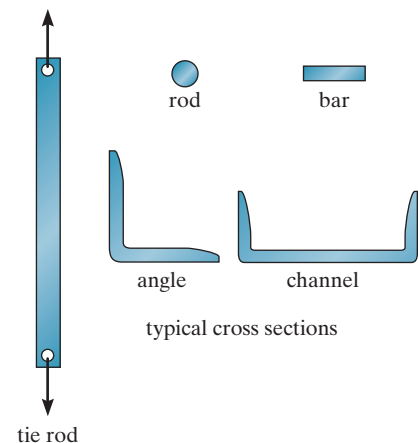

Fig. 1-1

**Beams.** *Beams* are usually straight horizontal members used primarily to carry vertical loads. Quite often they are classified according to the way they are supported, as indicated in Fig. 1–2. In particular, when the cross section varies the beam is referred to as a *tapered* or *haunched beam*. Beam cross sections may also be “built up” by adding plates to their top and bottom.

Beams are primarily designed to resist bending moment; however, if they are short and carry large loads, the internal shear force may become quite large and this force may govern their design. When the material used for a beam is a metal such as steel or aluminum, the cross section is most efficient when it is shaped as shown in Fig. 1–3. Here the forces developed in the top and bottom *flanges* of the beam form the necessary couple used to resist the applied moment  $M$ , whereas the *web* is effective in resisting the applied shear  $V$ . This cross section is commonly referred to as a *wide flange*, and it is normally formed as a single unit in a rolling mill in lengths up to 23 m. When the beam is required to have a very long span, and the loads applied are rather large, the cross section may take the form of a *plate girder*. This member is fabricated by using a large plate for the web and welding or bolting plates to its ends for flanges. The girder is often transported to the field in segments, and the segments are designed to be spliced or joined together at points where the girder carries a small internal moment.

**Concrete beams** generally have rectangular cross sections, since it is easy to construct this form directly on the job site. Because concrete is rather weak in resisting tension, steel “reinforcing rods” are cast into the beam within regions of the cross section subjected to tension. Precast concrete beams or girders have a variety of different cross sections, and so they are fabricated at a shop or yard and then transported to the job site.

Beams made from timber may be sawn from a solid piece of wood or laminated. **Laminated beams**, often called glulam beams, are constructed from strips of wood, which are fastened together using high-strength glues.

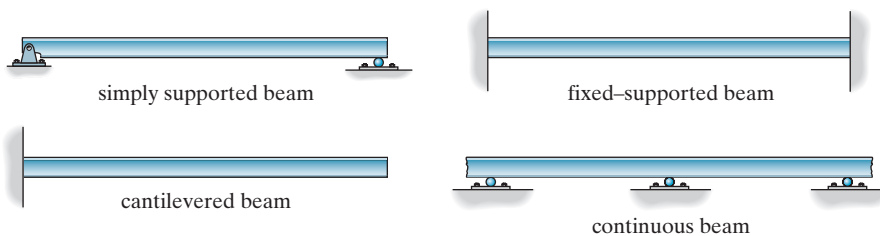
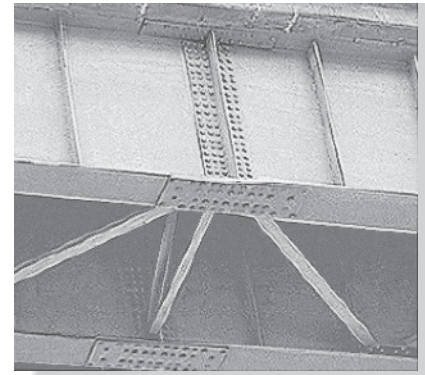

Fig. 1–2



Shown are typical splice plate joints used to connect the steel plate girders of a highway bridge.



The prestressed concrete girders are simply supported on the piers and are used for this highway bridge.

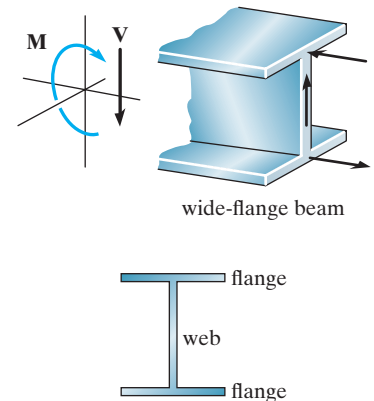

Fig. 1–3



Wide-flange members are often used for columns. Here is an example of a beam column.

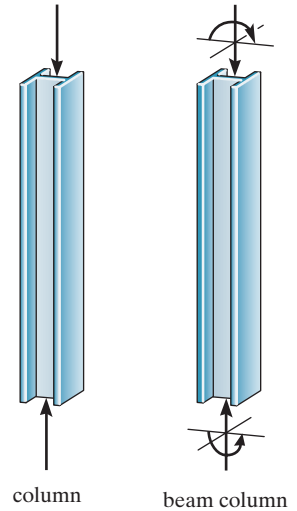

Fig. 1-4

**Columns.** Members that are generally vertical and resist axial compressive loads are referred to as **columns**, Fig. 1-4. Tubes and wide-flange cross sections are often used for metal columns, and circular and square cross sections with reinforcing rods are used for those made of concrete. Occasionally, columns are subjected to both an axial load and a bending moment as shown in the figure. These members are referred to as **beam columns**.

**Types of Structures.** A combination of structural elements is referred to as a **structural system**. Each system is constructed of one or more of four basic types of structures. Ranked in order of complexity of their force analysis, they are as follows.

**Trusses.** When the span of a structure is required to be long and its depth is not an important criterion for design, a truss may be selected. **Trusses** consist of slender elements, usually arranged as a series of triangular elements. **Planar trusses** are composed of members that lie in the same plane and are frequently used for bridge and roof support, whereas **space trusses** have members extending in three dimensions and are suitable for derricks and towers.

A truss supports its load through the tension and compression of its members, and as a result a truss uses less material than a solid beam to support a given load, Fig. 1-5. In general it is economically feasible to use a truss to cover spans ranging from 9 m to 122 m, although trusses have been used on occasion for spans of greater lengths.



An applied loading will cause bending of this truss, which develops compression in the top members and tension in the bottom members.

**Fig. 1-5**

**Cables and Arches.** Two other forms of structures used to span long distances are the cable and the arch. **Cables** are usually flexible and carry their loads in tension, Fig. 1-6a. They are commonly used to support bridges and building roofs. When used for these purposes, the cable has an advantage over the beam and the truss, especially for spans that are greater than 46 m. Because they are always in tension, cables will not become unstable and suddenly collapse or buckle, as may happen with beams or trusses. The use of cables, on the other hand, is limited only by their sag, weight, and methods of anchorage.

The **arch** achieves its strength in compression, since it has a reverse curvature to that of the cable. The arch must be rigid, however, in order to maintain its shape. Arches are frequently used in bridge structures, Fig. 1-6b, dome roofs, and for openings in masonry walls.



Cables support their loads in tension.

(a)



Arches support their loads in compression.

(b)

**Fig. 1-6**

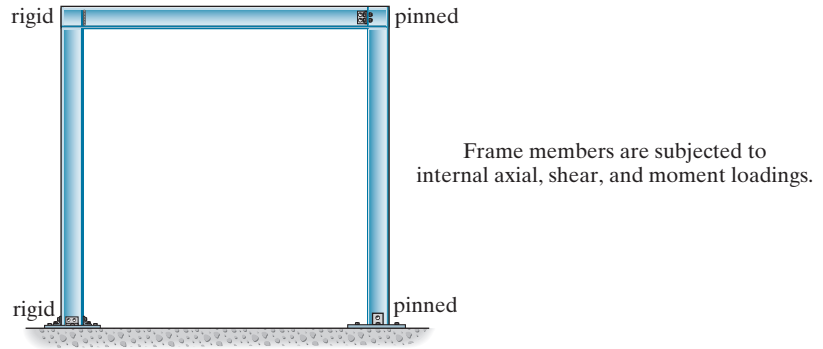

Fig. 1-7



Typical steel framework.

**Frames.** *Frames* are often used in buildings and are composed of beams and columns that are either pin or fixed connected, Fig. 1-7. Like trusses, frames extend in two or three dimensions.

**Surface Structures.** A *surface structure* is made of a material having a very small thickness compared to its other dimensions. Sometimes this material is very flexible and can take the form of a tent or air-inflated structure. In either case the material acts as a membrane that is subjected to pure tension.

Surface structures may also be made of rigid material such as reinforced concrete. As such they may be shaped as folded plates, cylinders, or hyperbolic paraboloids, and in any of these forms, they are referred to as *thin plates* or *shells*. In general, these types of structures are difficult to analyze, due to the three-dimensional geometry of their surface. Such an analysis is beyond the scope of this book and is instead covered in books devoted entirely to this subject.

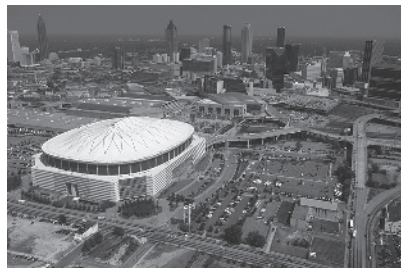

© Bob Krist/Documentary Value/Corbis/Alamy

The roof of the “Georgia Dome” in Atlanta, Georgia can be considered as a thin membrane.

## 1.3 LOADS

Once the dimensional requirements for a structure have been defined, it becomes necessary to determine the loads the structure must support. Often, it is the anticipation of the various loads that will be imposed on the structure that provides the basic type of structure that will be chosen for design. For example, high-rise structures must endure large lateral loadings caused by wind, and so shear walls and tubular frame systems are selected, whereas buildings located in areas prone to earthquakes must be designed having ductile frames and connections.

The actual design begins with those elements that are subjected to the primary loads the structure is intended to carry, and proceeds in sequence to the various supporting members until the foundation is reached. Thus, a building floor slab would be designed first, followed by the supporting beams, columns, and last, the foundation footings. In order to design a structure, it is therefore necessary to first specify the loads that act on it.

The design loading for a structure is often specified in codes. In general, the structural engineer works with two types of codes. **General building codes** specify the requirements of governmental bodies or organizations for minimum *design loads*, and **design codes** provide detailed technical standards that are used to establish the requirements for the actual structural design. Table 1.1 lists some of the important codes used in practice. It should be realized, however, that codes provide only a general guide for design. *The ultimate responsibility for the design lies with the structural engineer.*

Since a structure is generally subjected to several types of loads, a brief discussion of these loadings will now be presented to illustrate how one must consider their effects in practice.

**TABLE 1.1 Codes**

### General Building Codes

*Minimum Design Loads for Buildings and Other Structures*, ASCE/SEI 7-16,  
American Society of Civil Engineers

*International Building Code*

### Design Codes

*Building Code Requirements for Reinforced Concrete*, Am. Conc. Inst. (ACI)  
*Manual of Steel Construction*, American Institute of Steel Construction  
(AISC)

*Standard Specifications for Highway Bridges*, American Association of State  
Highway and Transportation Officials (AASHTO)

*National Design Specification for Wood Construction*, American Forest and  
Paper Association (AFPA)

*Manual for Railway Engineering*, American Railway Engineering and  
Maintenance-of-Way Association (AREMA)

**Dead Loads.** *Dead loads* consist of the weights of the various structural members and the weights of any objects that are *permanently attached* to the structure. Hence, for a building, the dead loads include the weights of the columns, beams, and girders, the floor slab, roofing, walls, windows, plumbing, electrical fixtures, and other miscellaneous attachments.

In some cases, a structural dead load can be estimated satisfactorily from simple formulas based on the weights and sizes of similar structures. Also, through experience one can sometimes derive a “feeling” for the magnitude of these loadings before doing any calculations to verify a result.

**TABLE 1.2 Minimum Densities for Design Loads from Materials\***

	kN/m <sup>3</sup>
Aluminum	27
Concrete, cinder	170
Concrete, stone	22.6
Clay, dry	9.9
Clay, damp	17.3
Sand and gravel, dry, loose	15.7
Sand and gravel, wet	18.9
Masonry, lightweight concrete	16.5
Masonry, normal weight units	21.2
Plywood	5.7
Steel, cold-drawn	77.3
Wood, Douglas Fir	5.3
Wood, Southern Pine	5.8
Wood, spruce	4.5

\*Minimum Densities for Design Loads from Materials. Reproduced with permission from American Society of Civil Engineers *Minimum Design Loads for Buildings and Other Structures*, ASCE/SEI 7-16. Copies of this standard may be purchased from ASCE at [www.asce.org/publications](http://www.asce.org/publications).

**TABLE 1.3 Minimum Design Dead Loads\***

<b>Walls</b>	kN/m <sup>2</sup>
102 mm clay brick	1.87
203 mm clay brick	3.78
305 mm clay brick	5.51
<b>Frame Partitions and Walls</b>	
Exterior stud walls with brick veneer	2.30
Windows, glass, frame and sash	0.38
Wood studs 51 × 102 mm, unplastered	0.19
Wood studs 51 × 102 mm, plastered one side	0.57
Wood studs 51 × 102 mm, plastered two sides	0.96
<b>Floor Fill</b>	
Cinder concrete, per mm	0.017
Lightweight concrete, plain, per mm	0.015
Stone concrete, per mm	0.023
<b>Ceilings</b>	
Acoustical fiberboard	0.05
Plaster on tile or concrete	0.24
Suspended metal lath and gypsum plaster	0.48
Asphalt shingles	0.10
Fiberboard, 13 mm	0.04

\*Minimum Design Dead Loads. Reproduced with permission from American Society of Civil Engineers *Minimum Design Loads for Buildings and Other Structures*, ASCE/SEI 7-16, American Society of Civil Engineers.





It is important to find the position of this moving load where it causes the largest compression in this bridge pier.

**Live Loads.** *Live loads* can vary both in their magnitude and location. They may be caused by the weights of objects temporarily placed on a structure, by moving vehicles, or by natural forces. The following are important examples of live loads that must be considered when designing a structure.

**Building Loads.** The floors of buildings are assumed to be subjected to *uniform live loads*, which depend on the purpose for which the building is designed. A representative sample of such *minimum live loadings*, taken from the ASCE 7-16 Standard, is shown in Table 1.4. The values are determined from a history of loading various buildings, and they include some protection against the possibility of overload, which can occur during construction or from vibrations while the building is in service. In addition to uniform distributed loads, some codes specify *minimum concentrated live loads*, caused by hand carts, automobiles, etc., which must also be applied to the floor system. For example, both uniform and concentrated live loads must be considered in the design of an automobile parking deck.

TABLE 1.4 Minimum Live Loads\*

Occupancy or Use	Live Load kN/m <sup>2</sup>	Occupancy or Use	Live Load kN/m <sup>2</sup>
Assembly areas and theaters		Residential	
Fixed seats	2.87	Dwellings (one- and two-family)	1.92
Movable seats	4.79	Hotels and multifamily houses	
Garages (passenger cars only)	1.92	Private rooms and corridors	1.92
Office buildings		Public rooms and corridors	4.79
Lobbies	4.79	Schools	
Offices	2.40	Classrooms	1.92
Storage warehouse		First-floor corridors	4.79
Light	6.00	Corridors above first floor	3.83
Heavy	11.97		

\*Minimum Live Loads. Reproduced with permission from American Society of Civil Engineers *Minimum Design Loads for Buildings and Other Structures*, ASCE/SEI 7-16, American Society of Civil Engineers.

For buildings having very large floor areas, many codes will allow a *reduction* in the uniform live load for the *floor*, since it is unlikely that the prescribed live load will occur simultaneously throughout the entire structure at any one time. For example, ASCE 7-16 allows a reduction of live load on a member having an *influence area* ( $K_{LL}A_T$ ) of 372 m<sup>2</sup> or more. This reduced live load is calculated using the following equation:

$$L = L_0 \left( 0.25 + \frac{4.57}{\sqrt{K_{LL}A_T}} \right) \quad (1-1)$$

where

$L$  = reduced design live load per square meter of floor area supported by the member.

$L_0$  = unreduced design live load per square meter of area supported by the member (see Table 1.4).

$K_{LL}$  = live load element factor. For interior columns  $K_{LL} = 4$ .

$A_T$  = tributary area in square meters.\*

The reduced live load defined by Eq. 1-1 is limited to not less than 50% of  $L_0$  for members supporting one floor, or not less than 40% of  $L_0$  for members supporting more than one floor. No reduction is allowed for loads exceeding 4.79 kN/m<sup>2</sup> on a member supporting one floor, or for a passenger vehicle garage.

\*Examples of tributary areas for beams and columns are given in Sec. 2.1.

## EXAMPLE 1.2

The office building shown in the photo has interior columns that are spaced 6 m apart in two perpendicular directions. Determine the reduced live load supported by a typical interior column located at ground level. The column only supports the floor above it.

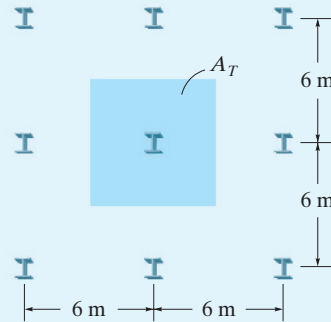

Fig. 1-9

### SOLUTION

As shown in Fig. 1-9, each interior column has a tributary area or effective loaded area of  $A_T = (6 \text{ m})(6 \text{ m}) = 36 \text{ m}^2$ . The live load is taken from Table 1.4:  $L_0 = 2.40 \text{ kN/m}^2 < 4.79 \text{ kN/m}^2$ . Since  $K_{LL} = 4$ , then  $4A_T = 4(36 \text{ m}^2) = 144 \text{ m}^2 > 37.2 \text{ m}^2$ . The live load can therefore be reduced using Eq. 1-1. Thus,

$$L = 2.40 \left( 0.25 + \frac{4.57}{\sqrt{144}} \right) = 1.514 \text{ kN/m}^2$$

The load reduction here is  $(1.514/2.40) 100\% = 63.1\% > 50\%$ . O.K. Therefore,

$$F_F = (1.514 \text{ kN/m}^2)(36 \text{ m}^2) = 54.50 \text{ kN} = 54.5 \text{ kN} \quad \text{Ans.}$$

**Highway Bridge Loads.** The primary live loads on bridge spans are those due to traffic, where the heaviest vehicle loading encountered is that caused by trucks. Specifications for truck loadings on highway bridges are reported in the *LRFD Bridge Design Specifications* of the American Association of State and Highway Transportation Officials (AASHTO). For two-axle trucks, these loads are designated with an H, followed by the weight of the truck in tons and another number which gives the year of the specifications in which the load was reported. H-series truck weights vary from 10 to 20 tons. However, bridges located on major highways, which carry a great deal of traffic, are designed for two-axle trucks plus a one-axle semitrailer as in Fig. 1–10. These are designated as HS loadings. In general, a truck loading selected for design depends upon the type of bridge, its location, and the type of traffic anticipated.

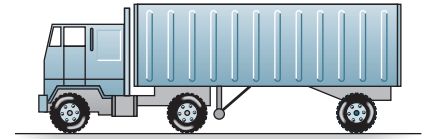

**Fig. 1–10**

**Railroad Bridge Loads.** The loadings on railroad bridges, as in Fig. 1–11, are tabulated in the *Specifications for Steel Railway Bridges* published by the American Railway Engineering and Maintenance-of-Way Association (AREMA). Since train loadings involve a complicated series of concentrated forces, to simplify hand calculations, tables and graphs are sometimes used in conjunction with influence lines, discussed in Chapter 6, to obtain their position on the bridge and the critical load.



**Fig. 1–11**

**Impact Loads.** Moving vehicles may bounce or sidesway as they move over a bridge, and therefore they impart an *impact* to the deck. The percentage increase of the live loads due to impact is called the **impact factor**,  $I$ . This factor is generally obtained from formulas developed from experimental evidence. For example, for highway bridges the AASHTO specifications require that

$$I = \frac{50}{3.2808L + 125} \quad \text{but not larger than } 0.3$$

where  $L$  is the length of the span in meters that is subjected to the live load.

In some cases, provisions for impact loading on building frames must also be taken into account. For example, the ASCE 7-16 Standard requires the weight of elevator machinery to be increased by 100%, and the loads on any hangers used to support floors and balconies to be increased by 33%.

**Wind Loads.** When the speed of the wind is very high, it can cause massive damage to a structure. The reason is that the pressure created by the wind is approximately proportional to the *square* of the wind speed. For example, in large *hurricanes* wind speeds can reach over 161 km/h, and in an F5 *tornado* (Fujita scale) the wind speeds can be over 483 km/h.

To understand the effect of a horizontal wind blowing over and around a building, consider the simple structure shown in Fig. 1–12. Here the positive pressure (pushing) on the front of the building is intensified, because the front will arrest the flow and redirect it over the roof and along the sides. Because air flows faster around these surfaces, by the Bernoulli effect, this higher velocity will cause a lower pressure (suction). This is especially true at the corners and at the ridge of the roof. Here the wind is redirected and the damage is the greatest. Behind the building there is also a suction, which produces a wake within the air stream.

The destruction due to the wind is increased if the building has an opening. If the opening is at the front, then the pressure within the building is increased, and this intensifies the external suction on the back, side walls, and the leeward side of the roof. If the opening is on a side wall, then the opposite effect occurs. Air will be sucked out of the building, lowering its inside pressure, and intensifying the pressure acting externally on the front of the building.

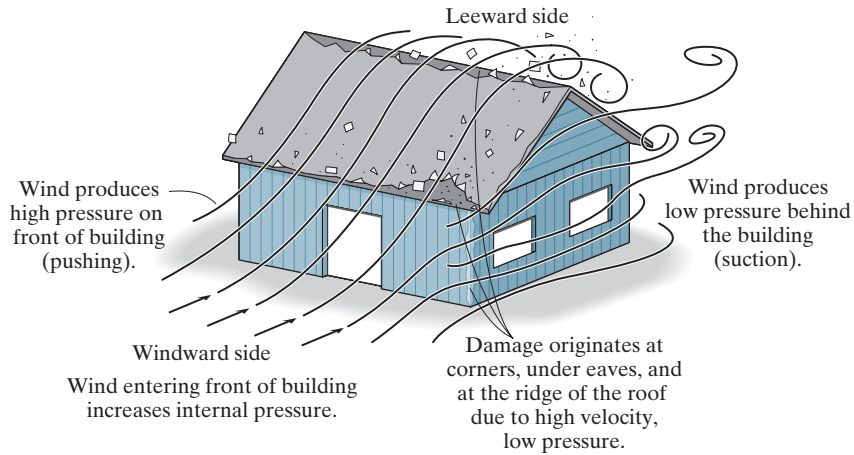

Fig. 1-12

For a high-rise building, the wind loading can be quite complex, and so these structures are often designed based on the behavior of a model of the building, tested in a wind tunnel. When doing so, it is important to consider the wind striking the structure from *any and all directions*.\*

The effects of lateral loadings developed by wind, can cause **racking**, or leaning of a building frame. To resist this effect, engineers often use cross bracing, knee or diagonal bracing, or shear walls. Examples that show the use of these members are indicated in the photos and in Fig. 17-9.



Cross bracing



Knee bracing



Shear walls

Diagonal bracing

\*You may want to investigate the case of the initial design of Citigroup Center. Construction of this skyscraper was completed in New York City in 1977, and only *afterwards* was it realized that the *quartering winds*, that is, those directed at the corners of the building, would produce enough force to actually collapse the building. Retrofits had to be made to the connections to provide the necessary strength to stiffen the structure. See [http://failures.wikispaces.com/Citicorp Center](http://failures.wikispaces.com/Citicorp+Center).

The effect of wind on a structure depends upon the density and velocity of the air, the angle of incidence of the wind, the shape and stiffness of the structure, and the roughness of its surface. For design purposes, wind loadings can be treated using either a static or a dynamic approach.

For the static approach, the fluctuating pressure caused by a constantly blowing wind is approximated by a mean velocity pressure that acts on the structure. This pressure  $q$  is defined by the air's kinetic energy per unit volume,  $q = \frac{1}{2}\rho V^2$ , where  $\rho$  is the density of the air and  $V$  is its velocity. According to the ASCE 7-16 Standard, this equation is modified to account for the structure's height and the terrain in which it is located. Also the importance of the structure is considered, as it relates to the risk to human life or the public welfare if it is damaged or loses its functionality. These modifications are represented by the following equation.



Hurricane winds caused this damage to a condominium in Miami, Florida.

© Jeff Greenberg 3 of 6/Alamy

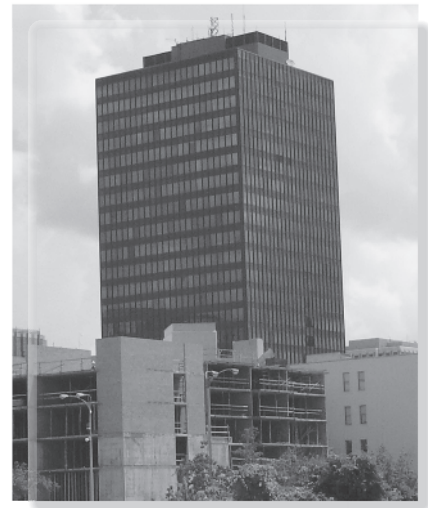

Some high-rise buildings must be able to resist hurricane winds having speeds of over 200 km/h.

$$q_z = 0.613K_z K_{zt} K_d K_e V^2 \text{ (N/m}^2\text{)} \quad (1-2)$$

Here

$V$  = the velocity in m/s of a 3-second gust of wind measured 10 m above the ground. Specific values depend upon the “risk category” of the structure obtained from a specified wind map. For example, if the structure is an agricultural or storage building, then it is of low risk to human life in the event of a failure. But if the structure is a hospital, then it is of high risk since its failure would cause substantial loss of human life.

$K_z$  = the velocity pressure exposure coefficient, which is a function of height and depends upon the ground terrain. Table 1.5 lists values for a structure which is located in open terrain with scattered low-lying obstructions.

$K_{zt}$  = a topographic factor that accounts for wind speed increases due to hills and escarpments. For flat ground  $K_{zt} = 1.0$ .

$K_d$  = a wind directionality factor that accounts for the direction of the wind. It is used when the structure is subjected to combinations of loads (see Sec. 1.4). For wind acting alone, we will take  $K_d = 1.0$ .

$K_e$  = a ground elevation factor; for a conservative design use  $K_e = 1.0$ .

**TABLE 1.5 Velocity Pressure Exposure Coefficient for Terrain with Low-Lying Obstructions**

$z$ (m)	$K_z$
0–4.6	0.85
6.1	0.90
7.6	0.94
9.1	0.98
12.2	1.04
15.2	1.09

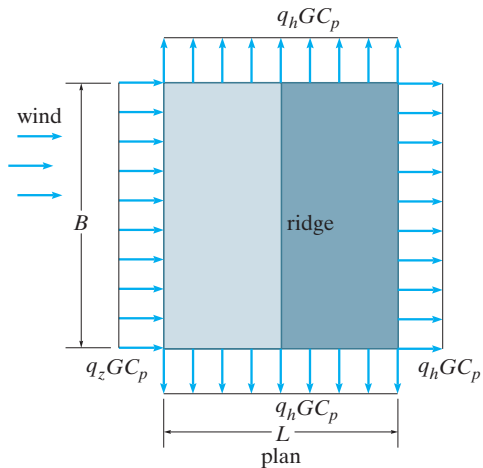

Surface	$L/B$	$C_p$	Use with
Windward wall	All values	0.8	$q_z$
Leeward wall	0–1	–0.5	$q_h$
	2	–0.3	
	$\geq 4$	–0.2	
Side walls	All values	–0.7	$q_h$

Wall pressure coefficients,  $C_p$

Fig. 1–13

**Design Wind Pressure for Enclosed Buildings.** Once the value for  $q_z$  is obtained from Eq. 1–2, the *design pressure* can be determined from a list of relevant equations listed in the ASCE 7-16 Standard. The choice depends upon the flexibility and height of the structure, and whether the design is for the main wind-force resisting system, or for the building’s components and cladding. For example, using a “directional procedure” the *wind-pressure* on an enclosed building of any height is determined using a two-termed equation resulting from both external and internal building pressures, namely,

$$p = qGC_p - q_h(GC_{pi}) \quad (1-3)$$

Here

$q = q_z$  for the windward wall at height  $z$  above the ground (Eq. 1–2), and  $q = q_h$  for the leeward wall, side walls, and roof, where  $z = h$ , the mean height of the roof.

$G$  = a wind-gust effect factor, which depends upon the exposure. For example, for a rigid structure,  $G = 0.85$ .

$C_p$  = a wall or roof pressure coefficient determined from a table. These tabular values for the walls and a roof pitch of  $\theta = 10^\circ$  are given in Fig. 1–13. Note in the elevation view that the pressure will vary with height on the windward side of the building, whereas on the remaining sides and on the roof the pressure is assumed to be constant. Negative values indicate pressures acting away from the surface (suction).

$(GC_{pi})$  = the internal pressure coefficient, which depends upon the type of openings in the building. For fully enclosed buildings  $(GC_{pi}) = \pm 0.18$ . Here the signs indicate that either positive or negative (suction) pressure can occur within the building.

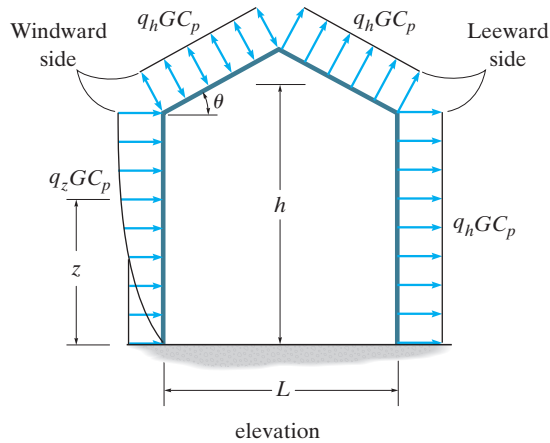

Wind direction	Windward angle $\theta$		Leeward angle
	$h/L$	$10^\circ$	$\theta = 10^\circ$
Normal to ridge	$\leq 0.25$	-0.7	-0.3
	0.5	-0.9	-0.5
	1.0	-1.3	-0.7

Maximum negative roof pressure coefficients,  $C_p$ , for use with  $q_h$

Fig. 1-13 (cont'd)

Application of Eq. 1-3 will involve calculations of wind pressures from each side of the building, with due considerations for the possibility of either positive or negative pressures acting on the building's interior.\*

For high-rise buildings or those having a shape or location that makes them wind sensitive, it is recommended that a *dynamic approach* be used to determine the wind loadings. The methodology for doing this is also outlined in the ASCE 7-16 Standard. It requires wind-tunnel tests to be performed on a scale model of the building and those surrounding it, in order to simulate the natural environment. Using proper scaling techniques, the pressure effects of the wind on the actual building can then be determined from data taken from pressure transducers attached to the model.

\*As with using any code, application of the requirements of the ASCE 7-16 Standard demands careful attention to details related to the use of formulas and graphs within the code. The recent failure of a fabric-covered steel truss structure, used by the Dallas Cowboys for football practice, was due to high winds. A review of the engineer's calculations, as recorded in *Civil Engineering*, April 2013, indicated a simple arithmetic error was made in calculating the slope angle  $\theta$  of the roof (see Fig. 1-13). Also, the internal pressure within the structure was not considered, along with other careless mistakes in modeling the structure for analysis. All this led to an underdesigned structure, which failed at a wind speed lower than the anticipated design speed. *The importance of a careful, accurate, and complete analysis cannot be overemphasized.*

### EXAMPLE 1.3

The enclosed building shown in the photo and in Fig. 1-14a is used for storage purposes, and is located on open flat terrain where the wind speed is  $V = 50$  m/s. When the wind is directed as shown, determine the design wind pressure acting on the roof and sides of the building using the ASCE 7-16 Specifications.

#### SOLUTION

First the wind pressure will be determined using Eq. 1-2. Also, for flat terrain,  $K_{zt} = 1.0$ . Since only wind loading is being considered, we will use  $K_d = 1.0$ , and  $K_e = 1.0$ . Therefore,

$$\begin{aligned} q_z &= 0.613 K_z K_{zt} K_d K_e V^2 \\ &= 0.613 K_z (1.0)(1.0)(1.0)(50)^2 \\ &= 1532.5 K_z \end{aligned}$$

From Fig. 1-14a,  $h' = 22.5 \tan 10^\circ = 3.967$  m so that the *mean* or average height of the roof is  $h = 7.5 + 3.967/2 = 9.48$  m. Using the values of  $K_z$  in Table 1.5, calculated values of the pressure profile are listed in the table in Fig. 1-14b. For  $z = h = 9.48$  m, the value of  $K_z$  was determined by linear interpolation, i.e.,  $(1.04 - 0.98)/(12.2 - 9.1) = (1.04 - K_z)/(12.2 - 9.48)$ , and so  $q_h = 1532.5(0.987) = 1513$  N/m<sup>2</sup>.

In order to apply Eq. 1-3 the gust factor is  $G = 0.85$  (rigid structure), and  $(GC_{pi}) = \pm 0.18$ . Thus,

$$\begin{aligned} p &= qGC_p - q_h(GC_{pi}) \\ &= q(0.85)C_p - 1513(\pm 0.18) \\ &= 0.85qC_p \mp 272.38 \end{aligned} \quad (1)$$

The pressure loadings are obtained from this equation using the calculated values for  $q_z$  listed in Fig. 1-14b in accordance with the wind-pressure profile in Fig. 1-13.

$z$ (m)	$K_z$	$q_z$ (N/m <sup>2</sup> )
0–4.6	0.85	1303
6.1	0.90	1379
7.6	0.94	1441
$h = 9.48$	0.987	1513

(b)

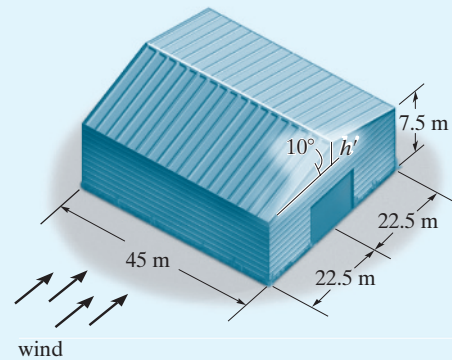

(a)

Fig. 1-14

**Windward Wall.** Here the pressure varies with height  $z$  since  $q_z G C_p$  must be used. For all values of  $L/B$ ,  $C_p = 0.8$ , so that from Eq. (1),

$$p_{0-4.6} = 0.85(1303)(0.8) \mp 272.38 = 613 \text{ N/m}^2 \text{ or } 1158 \text{ N/m}$$

$$p_{6.1} = 0.85(1379)(0.8) \mp 272.38 = 666 \text{ N/m}^2 \text{ or } 1210 \text{ N/m} \text{ Ans.}$$

$$p_{7.6} = 0.85(1441)(0.8) \mp 272.38 = 707 \text{ N/m}^2 \text{ or } 1252 \text{ N/m}$$

**Leeward Wall.** Here  $L/B = 2(22.5)/45 = 1$ , so that  $C_p = -0.5$ , Fig. 1-13. Also,  $q = q_h$  and so from Eq. (1),

$$p = 0.85(1513)(-0.5) \mp 272.38 = -916 \text{ N/m}^2 \text{ or } -371 \text{ N/m} \text{ Ans.}$$

**Side Walls.** For all values of  $L/B$ ,  $C_p = -0.7$ . and therefore since we must use  $q = q_h$  in Eq. (1), we have

$$p = 0.85(1513)(-0.7) \mp 272.38 = -1173 \text{ N/m}^2 \text{ or } -628 \text{ N/m}^2 \text{ Ans.}$$

**Windward Roof.** Here  $h/L = 9.48/2(22.5) = 0.211 < 0.25$ , so that  $C_p = -0.7$  and  $q = q_h$ . Thus,

$$p = 0.85(1513)(-0.7) \mp 272.38 = -1173 \text{ N/m}^2 \text{ or } -628 \text{ N/m}^2 \text{ Ans.}$$

**Leeward Roof.** In this case  $C_p = -0.3$ ; therefore with  $q = q_h$ , we get

$$p = 0.85(1513)(-0.3) \mp 272.38 = -658 \text{ N/m}^2 \text{ or } -113 \text{ N/m}^2 \text{ Ans.}$$

These two sets of loadings are shown on the elevation of the building, representing either positive or negative (suction) pressure, Fig. 1-14c. The main framing structure of the building must resist each of these loadings as well as separate loadings calculated from wind blowing on the front or rear of the building.

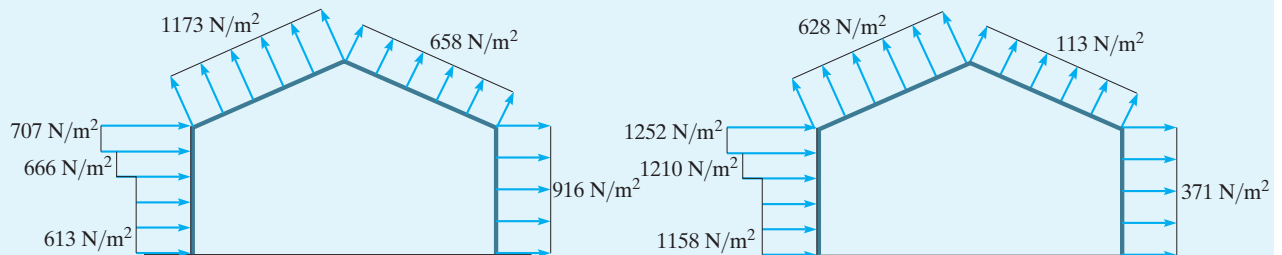

(c)

**Design Wind Pressure for Signs.** If the structure represents a sign, Fig. 1–15, the wind will produce a *resultant force* acting on the face of the sign which is determined from

$$F = q_h G C_f A_s \quad (1-4)$$

Here

$q_h$  = the wind pressure evaluated at the height  $h$ , measured from the ground to the top of the sign.

$G$  = the wind-gust effect factor defined previously.

$C_f$  = a force coefficient that depends upon the aspect ratio (width  $B$  of the sign to height  $s$  of the sign) and the clearance ratio (sign height  $s$  to the elevation  $h$ , measured from the ground to the top of the sign). For cases of wind directed normal to the sign and through its center, for  $B/s = 4$ , values are listed in Table 1.6.

$A_s$  = the area of the face of the sign in  $m^2$ .

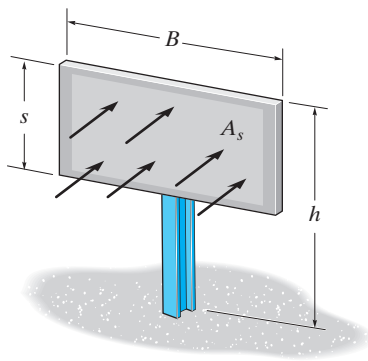

Fig. 1–15

TABLE 1.6 Force Coefficients for Above-Ground Solid Signs,  $C_f$

$s/h$	$C_f$
1	1.35
0.9	1.45
0.5	1.70
0.2	1.80
$\leq 0.16$	1.85

Hurricane-force winds acting on the face of this sign were strong enough to noticeably bend the two supporting arms, causing the material to yield. Proper design would have prevented this.



**Snow Loads.** In some parts of the country, roof loading due to snow can be quite severe, and therefore protection against possible failure is of primary concern. Design loadings typically depend on the building's general shape and roof geometry, wind exposure, location, its importance, and whether or not it is heated. Like wind, snow loads in the ASCE 7-16 Standard are generally determined from a zone map reporting 50-year recurrence intervals of an extreme snow depth. For example, on the relatively flat elevation throughout the mid-section of Illinois and Indiana, the ground snow loading is about  $0.96 \text{ kN/m}^2$ . However, for areas of Montana, specific case studies of ground snow loadings are needed due to the variable elevations throughout the state. Specifications for snow loads are covered in the ASCE 7-16 Standard, although no single code can cover all the implications of this type of loading.

If a roof is flat, defined as having a slope of less than 5%, then the pressure loading on the roof can be obtained by modifying the ground snow loading,  $p_g$ , by the following empirical formula

$$p_f = 0.7C_e C_t I_s p_g \quad (1-5)$$

Here

$C_e$  = an exposure factor which depends upon the terrain. For example, for a fully exposed roof in an unobstructed area,  $C_e = 0.8$ , whereas if the roof is sheltered and located in the center of a large city, then  $C_e = 1.2$ .

$C_t$  = a thermal factor which refers to the average temperature within the building. For unheated structures kept below freezing  $C_t = 1.2$ , whereas if the roof is supporting a normally heated structure, then  $C_t = 1.0$ .

$I_s$  = the importance factor as it relates to occupancy. For example,  $I_s = 0.80$  for agriculture and storage facilities, and  $I_s = 1.20$  for schools and hospitals.

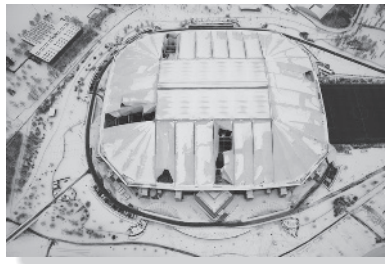

© Hans Blosssey/  
Imagebroker/SuperStock

Excessive snow and ice loadings acted on this roof and caused its collapse.