

Contents

1. Tension, Compression, and Shear	1
2. Axially Loaded Members	117
3. Torsion	283
4. Shear Forces and Bending Moments	385
5. Stresses in Beams (Basic Topics)	435
6. Stresses in Beams (Advanced Topics)	557
7. Analysis of Stress and Strain	637
8. Applications of Plane Stress (Pressure Vessels, Beams, and Combined Loadings)	725
9. Deflections of Beams	793
10. Statically Indeterminate Beams	885
11. Columns	943
12. Review of Centroids and Moments of Inertia	1025
Answers to Problems	1057
Appendix A: FE Exam Review Problems	1083

1

Tension, Compression, and Shear

Statics Review

Problem 1.2-1 Segments AB and BC of beam ABC are pin connected a small distance to the right of joint B (see figure). Axial loads act at A and at mid-span of AB . A concentrated moment is applied at joint B .

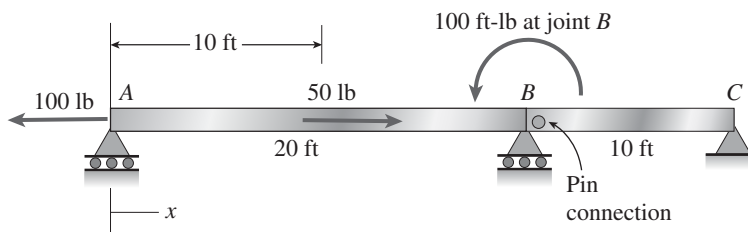

- Find reactions at supports A , B , and C .
- Find internal stress resultants N , V , and M at $x = 15$ ft.

Solution 1.2-1

(a) APPLY LAWS OF STATICS

$$\Sigma F_x = 0 \quad C_x = 100 \text{ lb} - 50 \text{ lb} = 50 \text{ lb}$$

$$\text{FBD of } BC \quad \Sigma M_B = 0 \quad C_y = \frac{1}{10 \text{ ft}}(0) = 0$$

$$\text{Entire FBD} \quad \Sigma M_A = 0 \quad B_y = \frac{1}{20 \text{ ft}}(-100 \text{ lb-ft}) = -5 \text{ lb}$$

$$\Sigma F_y = 0 \quad A_y = -B_y = 5 \text{ lb-ft}$$

$$\text{Reactions are } \boxed{A_y = 5 \text{ lb}} \quad \boxed{B_y = -5 \text{ lb}} \quad \boxed{C_x = 50 \text{ lb}} \quad \boxed{C_y = 0}$$

(b) INTERNAL STRESS RESULTANTS N , V , AND M AT $x = 15$ ft

Use FBD of segment from A to $x = 15$ ft

$$\Sigma F_x = 0 \quad \boxed{N = 100 \text{ lb} - 50 \text{ lb} = 50 \text{ lb}}$$

$$\Sigma F_y = 0 \quad \boxed{V = A_y = 5 \text{ lb}}$$

$$\Sigma M = 0 \quad \boxed{M = A_y 15 \text{ ft} = 75 \text{ lb-ft}}$$

Problem 1.2-2 Segments AB and BCD of beam $ABCD$ are pin connected at $x = 4$ m. The beam is supported by a sliding support at A and roller supports at C and D (see figure). A triangularly distributed load with peak intensity of 80 N/m acts on BC . A concentrated moment is applied at joint B .

- (a) Find reactions at supports A , C , and D .
- (b) Find internal stress resultants N , V , and M at $x = 5$ m.
- (c) Repeat parts (a) and (b) for the case of the roller support at C replaced by a linear spring of stiffness $k_y = 200$ kN/m.

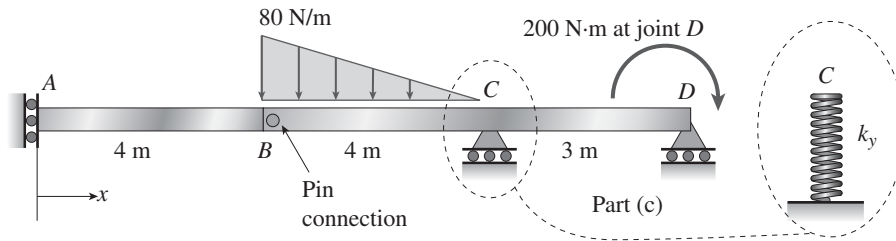

Solution 1.2-2

(a) APPLY LAWS OF STATICS

$$\Sigma F_x = 0 \quad A_x = 0$$

FBD of $AB \quad \Sigma M_B = 0 \quad M_A = 0$

Entire FBD $\Sigma M_C = 0 \quad D_y = \frac{1}{3 \text{ m}} \left[200 \text{ N}\cdot\text{m} - \frac{1}{2} (80 \text{ N/m}) 4 \text{ m} \left(\frac{2}{3} \right) 4 \text{ m} \right] = -75.556 \text{ N}$

$$\Sigma F_y = 0 \quad C_y = \frac{1}{2} (80 \text{ N/m}) 4 \text{ m} - D_y = 235.556 \text{ N}$$

Reactions are $M_A = 0 \quad A_x = 0 \quad C_y = 236 \text{ N} \quad D_y = -75.6 \text{ N}$

(b) INTERNAL STRESS RESULTANTS N , V , AND M AT $x = 5$ m

Use FBD of segment from A to $x = 5$ m; ordinate on triangular load at $x = 5$ m is $\frac{3}{4} (80 \text{ N/m}) = 60 \text{ N/m}$.

$$\Sigma F_x = 0 \quad N_x = -A_x = 0$$

$$\Sigma F_y = 0 \quad V = \frac{-1}{2} [(80 \text{ N/m} + 60 \text{ N/m}) 1 \text{ m}] = -70 \text{ N} \quad V = -70 \text{ N} \quad \text{Upward}$$

$$\Sigma M = 0 \quad M = -M_A - \frac{1}{2} (80 \text{ N/m}) 1 \text{ m} \left(\frac{2}{3} 1 \text{ m} \right) - \frac{1}{2} (60 \text{ N/m}) 1 \text{ m} \left(\frac{1}{3} 1 \text{ m} \right) = -36.667 \text{ N}\cdot\text{m}$$

(break trapezoidal load into two triangular loads in moment expression)

$$M = -36.7 \text{ N}\cdot\text{m} \quad \text{CW}$$

(c) REPLACE ROLLER SUPPORT AT C WITH SPRING SUPPORT

Structure remains statically determinate so all results above in (a) and (b) are unchanged.

Problem 1.2-3 Segments AB and BCD of beam $ABCD$ are pin connected at $x = 10$ ft. The beam is supported by a pin support at A and roller supports at C and D ; the roller at D is rotated by 30° from the x axis (see figure). A trapezoidal distributed load on BC varies in intensity from 5 lb/ft at B to 2.5 lb/ft at C . A concentrated moment is applied at joint A and a 40 lb inclined load is applied at mid-span of CD .

- Find reactions at supports A , C , and D .
- Find the resultant force in the pin connection at B .
- Repeat parts (a) and (b) if a rotational spring ($k_r = 50$ ft-lb/rad) is added at A and the roller at C is removed.

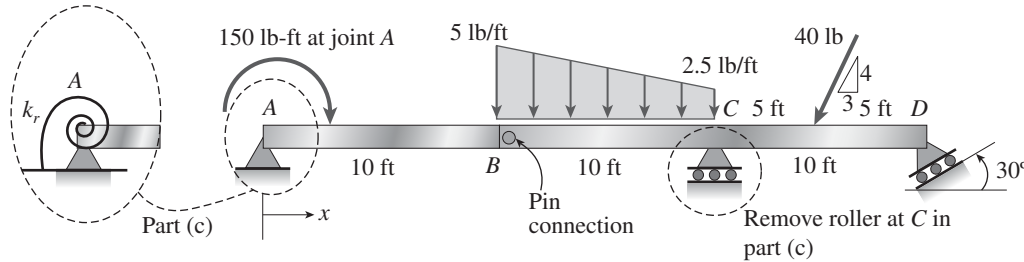

Solution 1.2-3

(a) STATICS

FBD of AB (cut through beam at pin): $\Sigma M_B = 0 \quad A_y = \frac{1}{10 \text{ ft}}(-150 \text{ lb-ft}) = -15 \text{ lb}$

Entire FBD: $\Sigma M_D = 0$

$$C_y = \frac{1}{10 \text{ ft}} \left[\frac{4}{5} 40 \text{ lb}(5 \text{ ft}) + \frac{1}{2} (2.5 \text{ lb/ft}) 10 \text{ ft} \left(10 \text{ ft} + \frac{10 \text{ ft}}{3} \right) + \frac{1}{2} (5 \text{ lb/ft}) 10 \text{ ft} \left(10 \text{ ft} + \frac{2}{3} 10 \text{ ft} \right) - 150 \text{ lb-ft} - A_y 30 \text{ ft} \right] = 104.333 \text{ lb}$$

$$\Sigma F_y = 0 \quad D_y = \frac{4}{5} 40 \text{ lb} + \frac{1}{2} (5 \text{ lb/ft} + 2.5 \text{ lb/ft}) 10 \text{ ft} - A_y - C_y = -19.833 \text{ lb} \quad \text{so} \quad D_x = \frac{-D_y}{\tan(60^\circ)} = 11.451 \text{ lb}$$

$$\Sigma F_x = 0 \quad A_x = \frac{3}{5} 40 \text{ lb} - D_x = 12.549 \text{ lb}$$

$$\boxed{A_x = 12.55 \text{ lb}, A_y = -15 \text{ lb}, C_y = 104.3 \text{ lb}, D_x = 11.45 \text{ lb}, D_y = -19.83 \text{ lb}}$$

(b) USE FBD OF AB ONLY; MOMENT AT PIN IS ZERO

$$F_{Bx} = -A_x \quad F_{Bx} = -12.55 \text{ lb} \quad F_{By} = -A_y \quad F_{By} = 15 \text{ lb} \quad \boxed{\text{Resultant}_B = \sqrt{F_{Bx}^2 + F_{By}^2} = 19.56 \text{ lb}}$$

(c) ADD ROTATIONAL SPRING AT A AND REMOVE ROLLER AT C ; APPLY EQUATIONS OF STATICAL EQUILIBRIUM

Use FBD of BCD $\Sigma M_B = 0$

$$D_y = \frac{1}{20 \text{ ft}} \left[\frac{1}{2} (2.5 \text{ lb/ft}) 10 \text{ ft} \left(\frac{2}{3} 10 \text{ ft} \right) + \frac{1}{2} (5 \text{ lb/ft}) 10 \text{ ft} \left(\frac{1}{3} 10 \text{ ft} \right) + \frac{4}{5} 40 \text{ lb} (15 \text{ ft}) \right] = 32.333 \text{ lb}$$

$$\text{so} \quad D_x = \frac{-D_y}{\tan(60^\circ)} = -18.668 \text{ lb}$$

Use entire FBD $\Sigma F_y = 0 \quad A_y = \frac{1}{2} (5 \text{ lb/ft} + 2.5 \text{ lb/ft}) 10 \text{ ft} + \frac{4}{5} (40 \text{ lb}) - D_y = 37.167 \text{ lb}$

$$\Sigma F_x = 0 \quad A_x = \frac{3}{5} (40 \text{ lb}) - D_x = 42.668 \text{ lb}$$

4 CHAPTER 1 Tension, Compression, and Shear

Use FBD of AB $\Sigma M_B = 0 \quad M_A = 150 \text{ lb-ft} + A_y(10 \text{ ft}) = 521.667 \text{ lb-ft}$

SO REACTIONS ARE $A_x = 42.7 \text{ lb}$ $A_y = 37.2 \text{ lb}$ $M_A = 522 \text{ lb-ft}$ $D_x = -18.67 \text{ lb}$ $D_y = 32.3 \text{ lb}$

RESULTANT FORCE IN PIN CONNECTION AT B

$F_{Bx} = -A_x \quad F_{By} = -A_y$ $\text{Resultant}_B = \sqrt{F_{Bx}^2 + F_{By}^2} = 56.6 \text{ lb}$

Problem 1.2-4 Consider the plane truss with a pin support at joint 3 and a vertical roller support at joint 5 (see figure).

- (a) Find reactions at support joints 3 and 5.
- (b) Find axial forces in truss members 11 and 13.

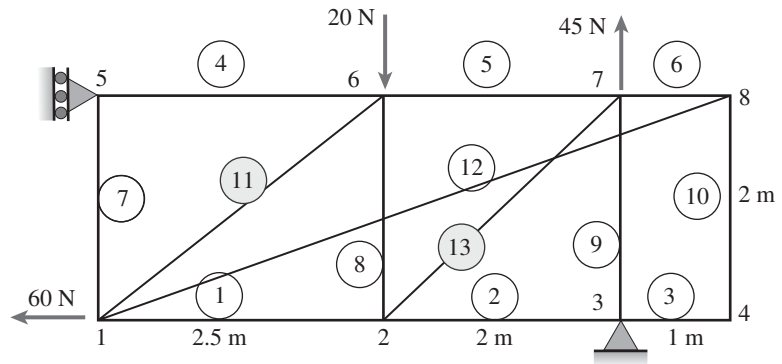

Solution 1.2-4

(a) STATICS

$\Sigma F_y = 0 \quad R_{3y} = 20 \text{ N} - 45 \text{ N} = -25 \text{ N}$

$\Sigma M_3 = 0 \quad R_{5x} = \frac{1}{2 \text{ m}} (20 \text{ N} \times 2 \text{ m}) = 20 \text{ N}$

$\Sigma F_x = 0 \quad R_{3x} = -R_{5x} + 60 \text{ N} = 40 \text{ N}$

(b) MEMBER FORCES IN MEMBERS 11 and 13

Number of unknowns: $m = 13 \quad r = 3 \quad m + r = 16$

Number of equations: $j = 8 \quad 2j = 16 \quad \text{So statically determinate}$

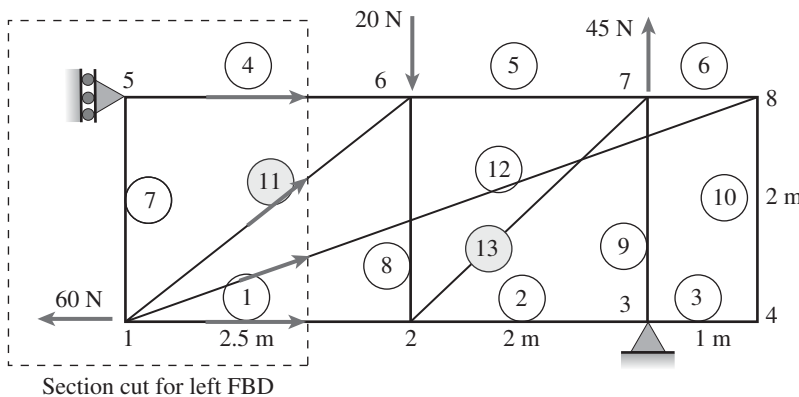

TRUSS ANALYSIS

- (1) $\Sigma F_V = 0$ at joint 4 so $F_{10} = 0$
- (2) $\Sigma F_V = 0$ at joint 8 so $F_{12} = 0$
- (3) $\Sigma F_H = 0$ at joint 5 so $F_4 = -R_{5x} = -20 \text{ N}$
- (4) Cut vertically through 4, 11, 12, and 1; use left FBD; sum moments about joint 2
 $F_{11V} = \frac{1}{2.5 \text{ m}} (R_{5x} - F_4)$ so $F_{11} = 0$
- (5) Sum vertical forces at joint 3; $F_9 = R_{3y}$
 $F_9 = 25 \text{ N}$

(6) Sum vertical forces at joint 7 $F_{13V} = 45 \text{ N} - F_9 = 20 \text{ N}$ $F_{13} = \sqrt{2} F_{13V} = 28.3 \text{ N}$

Problem 1.2-5 A plane truss has a pin support at A and a roller support at E (see figure).

- (a) Find reactions at all supports.
 (b) Find the axial force in truss member FE .

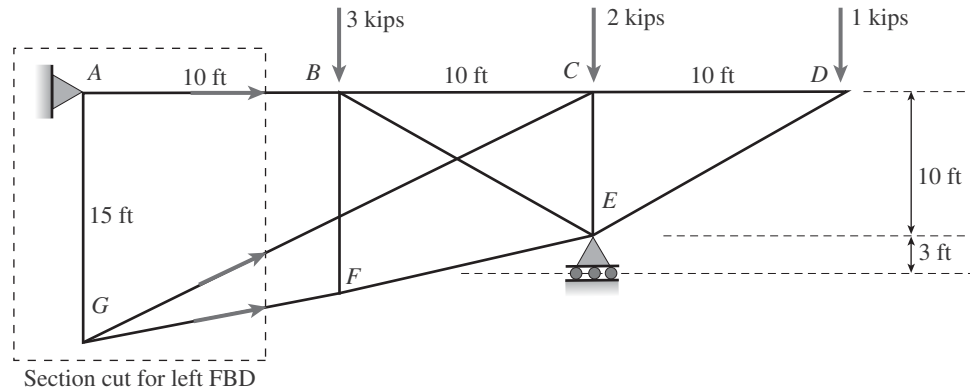

Solution 1.2-5

(a) STATICS

$$\Sigma F_x = 0 \quad A_x = 0$$

$$\Sigma M_A = 0 \quad E_y = \frac{1}{20 \text{ ft}}(3 \text{ k} \times 10 \text{ ft} + 2 \text{ k} \times 20 \text{ ft} + 1 \text{ k} \times 30 \text{ ft}) = 5 \text{ k}$$

$$\Sigma F_y = 0 \quad A_y = 3 \text{ k} + 2 \text{ k} + 1 \text{ k} - E_y = 1 \text{ k}$$

(b) MEMBER FORCE IN MEMBER FE

$$\text{Number of unknowns:} \quad m = 11 \quad r = 3 \quad m + r = 14$$

$$\text{Number of equations:} \quad j = 7 \quad 2j = 14 \quad \text{So statically determinate}$$

TRUSS ANALYSIS

(1) Cut vertically through AB , GC , and GF ; use left FBD; sum moments about C

$$F_{GFx}(15 \text{ ft}) - F_{GFy}(20 \text{ ft}) = A_y(20 \text{ ft}) = 20 \text{ ft-k} \quad F_{GFx} = F_{GF} \frac{10}{\sqrt{2^2 + 10^2}} \quad F_{GFy} = F_{GF} \frac{2}{\sqrt{2^2 + 10^2}}$$

$$\text{so } F_{GF} = \frac{A_y(20 \text{ ft})}{15 \text{ ft} \frac{10}{\sqrt{2^2 + 10^2}} - 20 \text{ ft} \frac{2}{\sqrt{2^2 + 10^2}}} = 1.854 \text{ k} \quad \text{and} \quad F_{GFx} = F_{GF} \frac{10}{\sqrt{2^2 + 10^2}} = 1.818 \text{ k}$$

$$(2) \text{ Sum horizontal forces at joint } F \quad F_{FE} = F_{GFx} = 1.818 \text{ k} \quad F_{FE} = \frac{\sqrt{10^2 + 3^2}}{10} F_{FE} = 1.898 \text{ k}$$

$$\boxed{F_{FE} = 1.898 \text{ k}}$$

Problem 1.2-6 A plane truss has a pin support at F and a roller support at D (see figure).

- (a) Find reactions at both supports.
- (b) Find the axial force in truss member FE .

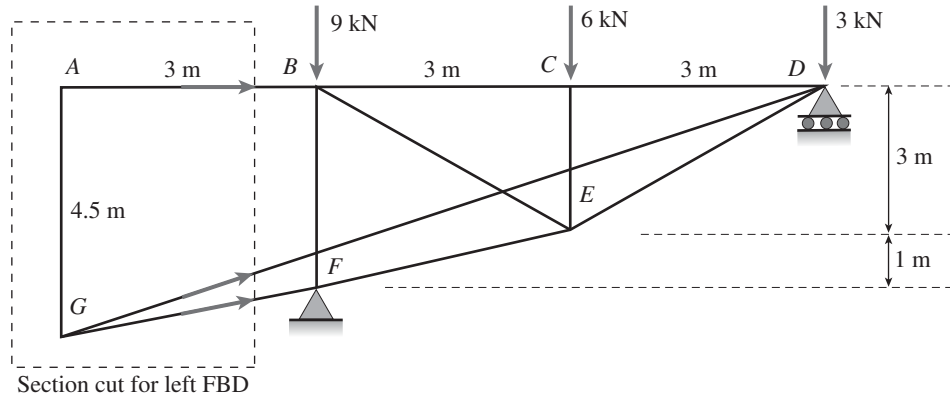

Solution 1.2-6

(a) STATICS

$$\begin{aligned} \Sigma F_x = 0 & \quad F_x = 0 \\ \Sigma M_F = 0 & \quad D_y = \frac{1}{6 \text{ m}} [3 \text{ kN}(6 \text{ m}) + 6 \text{ kN}(3 \text{ m})] = 6 \text{ kN} \\ \Sigma F_y = 0 & \quad F_y = 9 \text{ kN} + 6 \text{ kN} + 3 \text{ kN} - D_y = 12 \text{ kN} \end{aligned}$$

(b) MEMBER FORCE IN MEMBER FE

Number of unknowns: $m = 11$ $r = 3$ $m + r = 14$
 Number of equations: $j = 7$ $2j = 14$ So statically determinate

TRUSS ANALYSIS

- (1) Cut vertically through AB , GD , and GF ; use left FBD; sum moments about D to get $F_{GF} = 0$
- (2) Sum horizontal forces at joint F $F_{FE_x} = -F_x = 0$ so $F_{FE} = 0$

Problem 1.2-7 A space truss has three-dimensional pin supports at joints O , B , and C . Load P is applied at joint A and acts toward point Q . Coordinates of all joints are given in feet (see figure).

- (a) Find reaction force components B_x , B_z , and O_z .
- (b) Find the axial force in truss member AC .

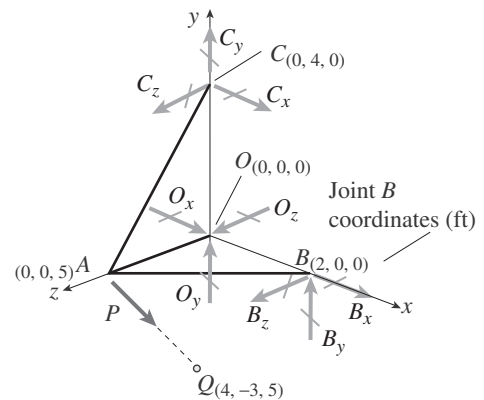

Solution 1.2-7

(a) FIND REACTIONS USING STATICS $m = 3$ $r = 9$ $m + r = 12$ $j = 4$ $3j = 12$
 $m + r = 3j$ So truss is statically determinate

$$r_{AQ} = \begin{pmatrix} 4 \\ -3 \\ 0 \end{pmatrix} \quad r_{OA} = \begin{pmatrix} 0 \\ 0 \\ 5 \end{pmatrix} \quad e_{AQ} = \frac{r_{AQ}}{|r_{AQ}|} = \begin{pmatrix} 0.8 \\ -0.6 \\ 0 \end{pmatrix} \quad P_A = P e_{AQ} = \begin{pmatrix} 0.8P \\ -0.6P \\ 0 \end{pmatrix} \quad r_{OC} = \begin{pmatrix} 0 \\ 4 \\ 0 \end{pmatrix} \quad r_{OB} = \begin{pmatrix} 2 \\ 0 \\ 0 \end{pmatrix}$$

$\Sigma M = 0$

$$M_O = r_{OA} \times P_A + r_{OC} \times \begin{pmatrix} C_x \\ C_y \\ C_z \end{pmatrix} + r_{OB} \times \begin{pmatrix} B_x \\ B_y \\ B_z \end{pmatrix} = \begin{pmatrix} 4C_z + 3.0P \\ 4.0P - 2B_z \\ 2B_y - 4C_x \end{pmatrix} \quad \text{so} \quad \Sigma M_x = 0 \quad \text{gives} \quad C_z = \frac{-3}{4}P$$

$$\Sigma M_y = 0 \quad \text{gives} \quad \boxed{B_z = 2P}$$

$\Sigma F = 0$

$$R_O = P_A + \begin{pmatrix} O_x \\ O_y \\ O_z \end{pmatrix} + \begin{pmatrix} B_x \\ B_y \\ B_z \end{pmatrix} + \begin{pmatrix} C_x \\ C_y \\ C_z \end{pmatrix} = \begin{pmatrix} B_x + C_x + O_x + 0.8P \\ B_y + C_y + O_y - 0.6P \\ O_z + \frac{5P}{4} \end{pmatrix} \quad \text{so} \quad \Sigma M_z = 0 \quad \text{gives} \quad \boxed{O_z = \frac{-5}{4}P}$$

METHOD OF JOINTS Joint O $\Sigma F_x = 0$ $O_x = 0$ $\Sigma F_y = 0$ $O_y = 0$

Joint B $\Sigma F_y = 0$ $B_y = 0$

Joint C $\Sigma F_x = 0$ $C_x = 0$

For entire structure $\Sigma F_x = 0$ gives $\boxed{B_x = -0.8P}$ $\Sigma F_y = 0$ $C_y = 0.6P - B_y = O_y$ $C_y = 0.6P$

(b) FORCE IN MEMBER AC

$$\Sigma F_z = 0 \quad \text{at joint C} \quad F_{AC} = \frac{\sqrt{4^2 + 5^2}}{5} |C_z| = \frac{3\sqrt{41}}{20} |P| \quad \boxed{F_{AC} = \frac{3\sqrt{41}}{20} P} \quad \text{tension} \quad \frac{3\sqrt{41}}{20} = 0.96$$

Problem 1.2-8 A space truss is restrained at joints O, A, B, and C, as shown in the figure. Load P is applied at joint A and load 2P acts downward at joint C.

- (a) Find reaction force components A_x , B_y , and B_z in terms of load variable P.
 (b) Find the axial force in truss member AB in terms of load variable P.

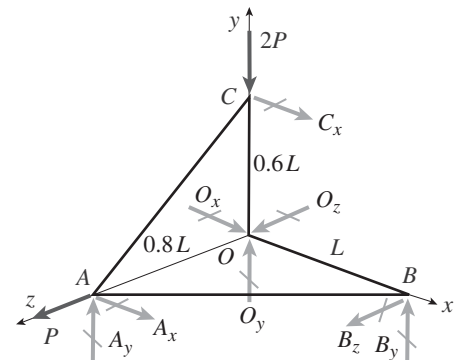

Solution 1.2-8

(a) FIND REACTIONS USING STATICS $m = 4$ $r = 8$ $m + r = 12$ $j = 4$ $3j = 12$

$m + r = 3j$ so truss is statically determinate

$$r_{OA} = \begin{pmatrix} 0 \\ 0 \\ 0.8L \end{pmatrix} \quad r_{OB} = \begin{pmatrix} L \\ 0 \\ 0 \end{pmatrix} \quad r_{OC} = \begin{pmatrix} 0 \\ 0.6L \\ 0 \end{pmatrix} \quad F_A = \begin{pmatrix} A_x \\ A_y \\ P \end{pmatrix} \quad F_B = \begin{pmatrix} 0 \\ B_y \\ B_z \end{pmatrix} \quad F_C = \begin{pmatrix} C_x \\ -2P \\ 0 \end{pmatrix} \quad F_O = \begin{pmatrix} O_x \\ O_y \\ O_z \end{pmatrix}$$

$\Sigma M = 0$

Resultant moment at O

$$M_O = r_{OA} \times F_A + r_{OB} \times F_B + r_{OC} \times F_C = \begin{pmatrix} -0.8A_yL \\ 0.8A_xL - B_zL \\ B_yL - 0.6C_xL \end{pmatrix} \quad \text{so} \quad \Sigma M_x = 0 \quad \text{gives} \quad A_y = 0$$

$\Sigma F = 0$

Resultant force at O

$$R_O = F_O + F_A + F_B + F_C = \begin{pmatrix} A_x + C_x + O_x \\ A_y + B_y + O_y - 2P \\ B_z + O_z + P \end{pmatrix}$$

METHOD OF JOINTS Joint O $\Sigma F_z = 0$ $O_z = 0$

so from $\Sigma F_z = 0$ $B_z = -P$ and $\Sigma M_y = 0$ $A_x = \frac{B_z}{0.8} = -1.25P$

Joint B $\Sigma F_y = 0$ $B_y = 0$

Joint C $\Sigma F_x = 0$ $C_x = 0$

(b) FORCE IN MEMBER AB

$\Sigma F_z = 0$ at joint B $F_{AB} = \frac{\sqrt{(0.8L)^2 + L^2}}{0.8L} |B_z|$ $|B_z| = |P|$ $\frac{\sqrt{(0.8L)^2 + L^2}}{0.8L} = 1.601$

$F_{AB} = 1.601P$ tension

Problem 1.2-9 A space truss is restrained at joints A , B , and C , as shown in the figure. Load $2P$ is applied at in the $-x$ direction at joint A , load $3P$ acts in the $+z$ direction at joint B and load P is applied in the $+z$ direction at joint C . Coordinates of all joints are given in terms of dimension variable L (see figure).

- (a) Find reaction force components A_y and A_z in terms of load variable P .
- (b) Find the axial force in truss member AB in terms of load variable P .

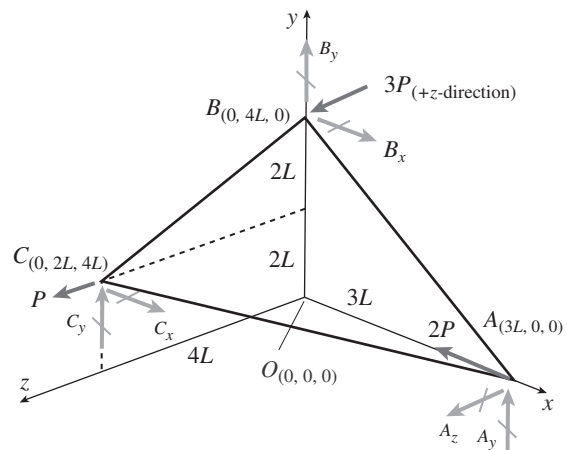

Solution 1.2-9(a) FIND REACTIONS USING STATICS $m = 3$ $r = 6$ $m + r = 9$ $j = 3$ $3j = 9$ $m + r = 3j$ So truss is statically determinate

$$r_{OA} = \begin{pmatrix} 3L \\ 0 \\ 0 \end{pmatrix} \quad r_{OB} = \begin{pmatrix} 0 \\ 4L \\ 0 \end{pmatrix} \quad r_{OC} = \begin{pmatrix} 0 \\ 2L \\ 4L \end{pmatrix} \quad F_A = \begin{pmatrix} -2P \\ A_y \\ A_z \end{pmatrix} \quad F_B = \begin{pmatrix} B_x \\ B_y \\ 3P \end{pmatrix} \quad F_C = \begin{pmatrix} C_x \\ C_y \\ P \end{pmatrix}$$

$\Sigma M = 0$

Resultant moment at O

$$M_O = r_{OA} \times F_A + r_{OB} \times F_B + r_{OC} \times F_C = \begin{pmatrix} 14LP - 4C_yL \\ 4C_xL - 3A_zL \\ 3A_yL - 4B_xL - 2C_xL \end{pmatrix} \quad \text{so} \quad \Sigma M_x = 0 \quad \text{gives} \quad C_y = \frac{14}{4}P$$

$\Sigma F = 0$

Resultant force at O

$$R_O = F_A + F_B + F_C = \begin{pmatrix} B_x + C_x - 2P \\ A_y + B_y + C_y \\ A_z + 4P \end{pmatrix} \quad \text{so} \quad \Sigma F_z = 0 \quad \text{gives} \quad \boxed{A_z = -4.0P}$$

METHOD OF JOINTS

$$\text{Joint A} \quad \Sigma F_z = 0 \quad F_{ACz} = -A_z = 4.0P \quad \text{so} \quad F_{ACy} = \frac{2}{4}F_{ACz} = 2.0P \quad F_{ACx} = \frac{3}{4}F_{ACz} = 3.0P$$

$$\Sigma F_x = 0 \quad F_{ABx} = -2P - F_{ACx} = -3.0P - 2P \quad \text{so} \quad F_{ABy} = \frac{4}{3}F_{ABx} = -4.0P - \frac{8P}{3}$$

$$\Sigma F_y = 0 \quad A_y = -(F_{ABy} + F_{ACy}) = \frac{8P}{3} + 4.0P + -2.0P \quad \boxed{A_y = 4.67P}$$

(b) FORCE IN MEMBER AB

$$F_{AB} = \sqrt{F_{ABx}^2 + F_{ABy}^2} \quad F_{AB} = -\sqrt{5^2 + \left(\frac{20}{3}\right)^2}P = -\frac{25P}{3} \quad \frac{25}{3} = 8.33$$

$$\boxed{F_{AB} = -8.33P} \quad \text{compression}$$

Problem 1.2-10 A space truss is restrained at joints A , B , and C , as shown in the figure. Load P acts in the $+z$ direction at joint B and in the $-z$ direction at joint C . Coordinates of all joints are given in terms of dimension variable L (see figure). Let $P = 5$ kN and $L = 2$ m.

- (a) Find the reaction force components A_z and B_x .
- (b) Find the axial force in truss member AB .

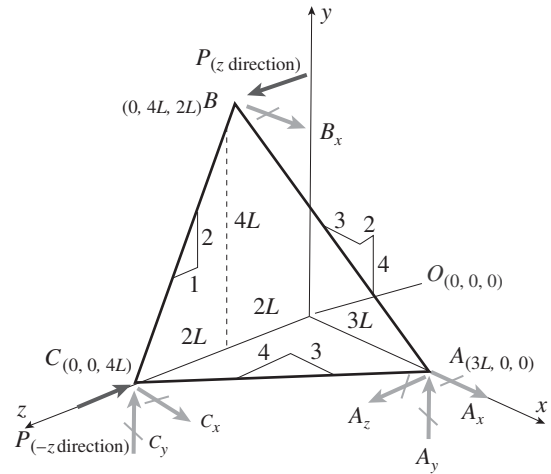

Solution 1.2-10

(a) FIND REACTIONS USING STATICS $m = 3$ $r = 6$ $m + r = 9$ $j = 3$ $3j = 9$
 $m + r = 3j$ so truss is statically determinate

$L = 2$ m $P = 5$ kN

$$r_{OA} = \begin{pmatrix} 3L \\ 0 \\ 0 \end{pmatrix} \quad r_{OB} = \begin{pmatrix} 0 \\ 4L \\ 2L \end{pmatrix} \quad r_{OC} = \begin{pmatrix} 0 \\ 0 \\ 4L \end{pmatrix} \quad F_A = \begin{pmatrix} A_x \\ A_y \\ A_z \end{pmatrix} \quad F_B = \begin{pmatrix} B_x \\ 0 \\ P \end{pmatrix} \quad F_C = \begin{pmatrix} C_x \\ C_y \\ -P \end{pmatrix}$$

$\Sigma F = 0$

Resultant force at O $R_O = F_A + F_B + F_C = \begin{pmatrix} A_x + B_x + C_x \\ A_y + C_y \\ A_z \end{pmatrix}$ so $\Sigma F_z = 0$ gives $A_z = 0$

RESULTANT MOMENT AT A

$$r_{AC} = \begin{pmatrix} -3L \\ 0 \\ 4L \end{pmatrix} \quad e_{AC} = \frac{r_{AC}}{|r_{AC}|} = \begin{pmatrix} -0.6 \\ 0 \\ 0.8 \end{pmatrix} \quad r_{AB} = \begin{pmatrix} -3L \\ 4L \\ 2L \end{pmatrix}$$

$$M_A = r_{AB} \times F_B + r_{AC} \times F_C = \begin{pmatrix} 120 \text{ kN} - 24C_y \\ 12B_x + 24C_x \\ -24B_x - 18C_y \end{pmatrix} \quad M_A e_{AC} = -19.2B_x - 72.0 \text{ kN} \quad \text{so } B_x = \frac{-72}{19.2} \text{ kN} = -3.75 \text{ kN}$$

(b) FORCE IN MEMBER AB

Method of joints at B $\Sigma F_x = 0$ $F_{ABx} = -B_x$ $F_{AB} = \frac{\sqrt{29}}{3} F_{ABx} = 6.73 \text{ kN}$

Problem 1.2-11 A stepped shaft ABC consisting of two solid, circular segments is subjected to torques T_1 and T_2 acting in opposite directions, as shown in the figure. The larger segment of the shaft has a diameter of $d_1 = 2.25$ in. and a length of $L_1 = 30$ in.; the smaller segment has a diameter $d_2 = 1.75$ in. and a length $L_2 = 20$ in. The torques are $T_1 = 21,000$ lb-in. and $T_2 = 10,000$ lb-in.

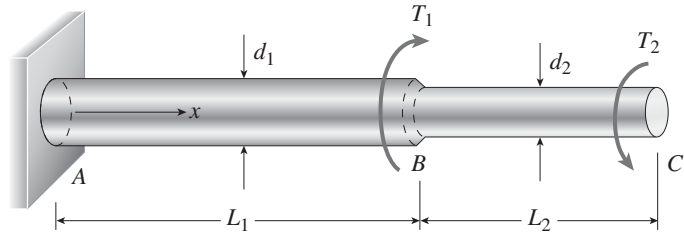

- (a) Find reaction torque T_A at support A.
- (b) Find the internal torque $T(x)$ at two locations: $x = L_1/2$ and $x = L_1 + L_2/2$. Show these internal torques on properly drawn free-body diagrams (FBDs).

Solution 1.2-11

(a) APPLY LAWS OF STATICS $L_1 = 30$ in. $L_2 = 20$ in. $T_1 = 21000$ lb-in. $T_2 = 10000$ lb-in.

$\Sigma M_x = 0$ $T_A = T_1 - T_2 = 11,000$ lb-in.

(b) INTERNAL STRESS RESULTANT T AT TWO LOCATIONS

Cut shaft at midpoint between A and B at $x = L_1/2$ $\Sigma M_x = 0$ $T_{AB} = -T_A = -11,000$ lb-in.
 (use left FBD)

Cut shaft at midpoint between B and C at $x = L_1 + L_2/2$ $\Sigma M_x = 0$ $T_{BC} = T_2 = 10,000$ lb-in.
 (use right FBD)

Problem 1.2-12 A stepped shaft ABC consisting of two solid, circular segments is subjected to uniformly distributed torque t_1 acting over segment 1 and concentrated torque T_2 applied at C, as shown in the figure. Segment 1 of the shaft has a diameter of $d_1 = 57$ mm and length of $L_1 = 0.75$ m; segment 2 has a diameter $d_2 = 44$ mm and length $L_2 = 0.5$ m. Torque intensity $t_1 = 3100$ N·m/m and $T_2 = 1100$ N·m.

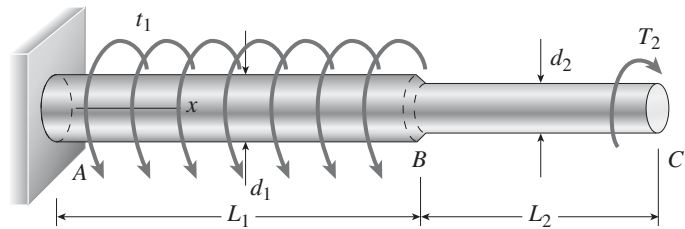

- (a) Find reaction torque T_A at support A.
- (b) Find the internal torque $T(x)$ at two locations: $x = L_1/2$ and $x = L_1 + L_2/2$. Show these internal torques on properly drawn free-body diagrams (FBDs).

Solution 1.2-12

(a) REACTION TORQUE AT A $L_1 = 0.75$ m $L_2 = 0.75$ m $t_1 = 3100$ N·m/m $T_2 = 1100$ N·m

Statics $\Sigma M_x = 0$ $T_A = -t_1 L_1 + T_2 = -1225$ N·m $T_A = -1225$ N·m

(b) INTERNAL TORSIONAL MOMENTS AT TWO LOCATIONS

Cut shaft between A and B $T_1(x) = -T_A - t_1 x$ $T_1\left(\frac{L_1}{2}\right) = 62.5$ N·m
 (use left FBD)

Cut shaft between B and C $T_2(x) = -T_A - t_1 L_1$ $T_2\left(L_1 + \frac{L_2}{2}\right) = -1100$ N·m
 (use left FBD)

Problem 1.2-13 A plane frame is restrained at joints A and C , as shown in the figure. Members AB and BC are pin connected at B . A triangularly distributed lateral load with peak intensity of 90 lb/ft acts on AB . A concentrated moment is applied at joint C .

- (a) Find reactions at supports A and C .
- (b) Find internal stress resultants N , V , and M at $x = 3 \text{ ft}$ on column AB .

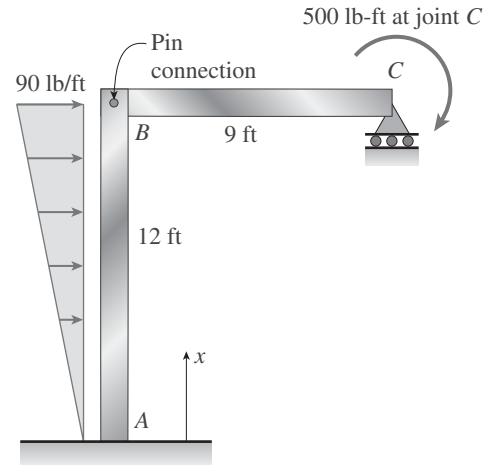

Solution 1.2-13

(a) STATICS

$$\Sigma F_H = 0 \quad A_x = \frac{-1}{2}(90 \text{ lb/ft}) 12 \text{ ft} = -540 \text{ lb}$$

$$\Sigma F_V = 0 \quad A_y + C_y = 0$$

$$\Sigma M_{FBD BC} = 0 \quad C_y = \frac{500 \text{ lb-ft}}{9 \text{ ft}} = 55.6 \text{ lb} \quad A_y = -C_y = -55.6 \text{ lb}$$

$$\Sigma M_A = 0 \quad M_A = 500 \text{ lb-ft} + \frac{1}{2}(90 \text{ lb/ft}) 12 \text{ ft} \left(\frac{2}{3} 12 \text{ ft}\right) - C_y 9 \text{ ft} = 4320 \text{ lb-ft}$$

(b) INTERNAL STRESS RESULTANTS

$$N = -A_y = 55.6 \text{ lb}$$

$$V = -A_x - \frac{1}{2} \left(\frac{3}{12} 90 \text{ lb/ft}\right) 3 \text{ ft} = 506 \text{ lb}$$

$$M = -M_A - A_x 3 \text{ ft} - \frac{1}{2} \left(\frac{3}{12} 90 \text{ lb/ft}\right) 3 \text{ ft} \left(\frac{1}{3} 3 \text{ ft}\right) = -2734 \text{ lb-ft}$$

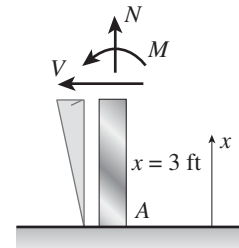

Problem 1.2-14 A plane frame is restrained at joints *A* and *D*, as shown in the figure. Members *AB* and *BCD* are pin connected at *B*. A triangularly distributed lateral load with peak intensity of 80 N/m acts on *CD*. An inclined concentrated force of 200 N acts at the mid-span of *BC*. An inclined concentrated force of 200 N acts at the mid-span of *BC*.

- (a) Find reactions at supports *A* and *D*.
- (b) Find resultant forces in the pins at *B* and *C*.

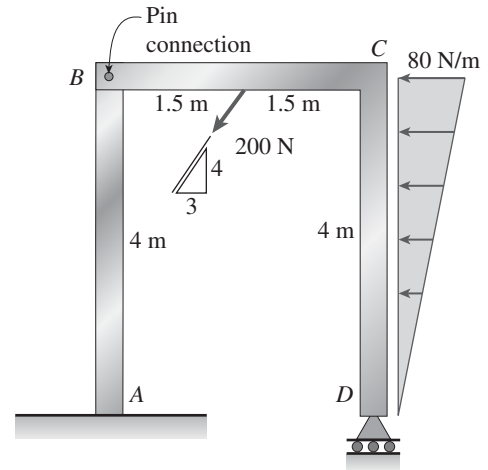

Solution 1.2-14

(a) STATICS

$$\Sigma F_x = 0 \quad A_x = \frac{3}{5}(200 \text{ N}) + \frac{1}{2}(80 \text{ N/m})4 \text{ m} = 280 \text{ N}$$

$$\Sigma M_{BRHFB} = 0 \quad D_y = \frac{1}{3 \text{ m}} \left[\frac{4}{5}(200 \text{ N})(1.5 \text{ m}) + \frac{1}{2}(80 \text{ N/m})4 \text{ m} \left(\frac{1}{3}4 \text{ m} \right) \right]$$

$$= 151.1 \text{ N} < \text{ use right hand FBD (BCD only)}$$

$$\Sigma F_y = 0 \quad A_y = -D_y + \frac{4}{5}(200 \text{ N}) = 8.89 \text{ N}$$

$$\Sigma M_A = 0 \quad M_A = \frac{4}{5}(200 \text{ N})(1.5 \text{ m}) - \frac{3}{5}(200 \text{ N})(4 \text{ m}) - D_y 3 \text{ m} - \frac{1}{2}(80 \text{ N/m})4 \text{ m} \left(\frac{2}{3}4 \text{ m} \right) = -1120 \text{ N}\cdot\text{m}$$

(b) RESULTANT FORCE IN PIN AT *B*

LEFT HAND FBD (SEE FIGURE)

$$F_{Bx} = -A_x = -280 \text{ N} \quad F_{By} = -A_y = -8.89 \text{ N}$$

RIGHT HAND FBD

$$F_{Bx} = \frac{3}{5}(200 \text{ N}) + \frac{1}{2}(80 \text{ N/m})4 \text{ m} = 280 \text{ N}$$

$$F_{By} = \frac{4}{5}(200 \text{ N}) - D_y = 8.89 \text{ N}$$

$$\text{Resultant}_B = \sqrt{F_{Bx}^2 + F_{By}^2} = 280 \text{ N}$$

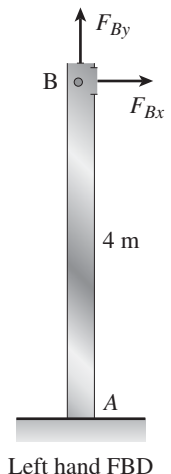

Problem 1.2-15 A 200 lb trap door (AB) is supported by a strut (BC) which is pin connected to the door at B (see figure).

- (a) Find reactions at supports A and C .
- (b) Find internal stress resultants N , V , and M on the trap door at 20 in. from A .

$$L_{BC} = \frac{\frac{4}{5} \cdot 30 \text{ in.}}{\frac{2}{\sqrt{5}}} = 26.833 \text{ in.}$$

$$L_{AC} = \frac{3}{5}(30 \text{ in.}) + \frac{1}{\sqrt{5}} L_{BC} = 30 \text{ in.}$$

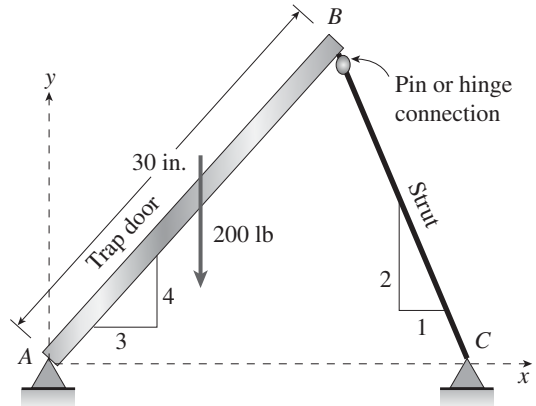

Solution 1.2-15

(a) STATICS

$$\begin{aligned} \Sigma M_A = 0 \quad C_y &= \frac{1}{L_{AC}} \left[200 \text{ lb} \left(\frac{1}{2} \right) \left(\frac{3}{5} \right) 30 \text{ in.} \right] = 60 \text{ lb} & C_x &= \frac{-1}{2} C_y = -30 \text{ lb} \\ \Sigma F_x = 0 \quad A_x &= -C_x = 30 \text{ lb} & & \text{(resultant of } C_x \text{ and } C_y \text{ acts along line of strut)} \\ \Sigma F_y = 0 \quad A_y &= 200 \text{ lb} - C_y = 140 \text{ lb} \end{aligned}$$

(b) INTERNAL STRESS RESULTANTS N , V , M (SEE FIGURE)

Distributed weight of door in $-y$ direction $w = \frac{200 \text{ lb}}{30 \text{ in.}} = 6.667 \text{ lb/in.}$

Components of w along and perpendicular to door

$$w_a = \frac{4}{5} w = 5.333 \text{ lb/in.} \quad w_p = \frac{3}{5} w = 4 \text{ lb/in.}$$

$$N = w_a(20 \text{ in.}) - \frac{3}{5} A_x - \frac{4}{5} A_y = -23.333 \text{ lb}$$

$$V = -w_p(20 \text{ in.}) - \frac{4}{5} A_x + \frac{3}{5} A_y = -20 \text{ lb}$$

$$M = -w_p(20 \text{ in.}) \frac{20 \text{ in.}}{2} - \frac{4}{5} A_x(20 \text{ in.}) + \frac{3}{5} A_y(20 \text{ in.}) = 33.333 \text{ lb-ft}$$

$N = -23.3 \text{ lb}$ $V = -20 \text{ lb}$ $M = 33.3 \text{ lb-ft}$

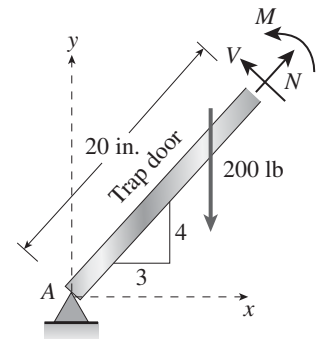

Problem 1.2-16 A plane frame is constructed by using a pin connection between segments *ABC* and *CDE*. The frame has pin supports at *A* and *E* and has joint loads at *B* and *D* (see figure).

- (a) Find reactions at supports *A* and *E*.
- (b) Find resultant force in the pin at *C*.

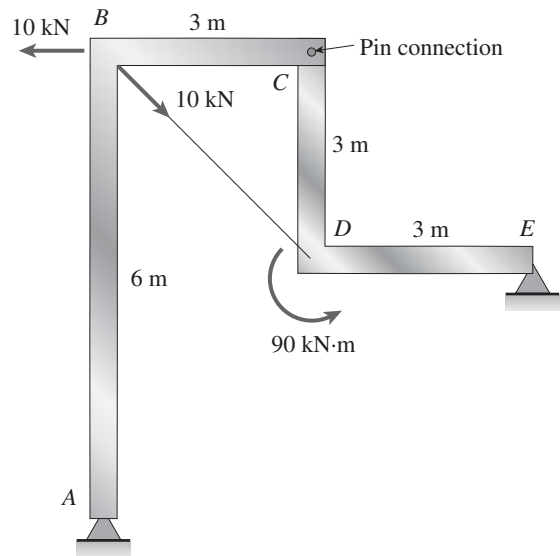

Solution 1.2-16

(a) STATICS

$$\Sigma M_A = 0$$

$$10 \text{ kN}(6 \text{ m}) - 10 \text{ kN}\left(\frac{1}{\sqrt{2}}\right)(6 \text{ m}) + 90 \text{ kN}\cdot\text{m} + E_y(6 \text{ m}) - E_x(3 \text{ m}) = 6E_y \text{ m} - 3E_x \text{ m} + 150 \text{ kN}\cdot\text{m} - 30\sqrt{2} \text{ kN}\cdot\text{m}$$

$$\text{so } 6E_y \text{ m} - 3E_x \text{ m} + 150 \text{ kN}\cdot\text{m} - 30\sqrt{2} \text{ kN}\cdot\text{m} = 0$$

$$\text{or } -E_x + 2E_y = \frac{-(150 \text{ kN}\cdot\text{m} - 30\sqrt{2} \text{ kN}\cdot\text{m})}{3 \text{ m}} = -35.858 \text{ kN}$$

$\Sigma M_{CRHFB} = 0$ < right hand FBD (*CDE*) - see figure.

$$(E_x + E_y) 3 \text{ m} = -90 \text{ kN}\cdot\text{m} \quad E_x + E_y = \frac{-90 \text{ kN}\cdot\text{m}}{3 \text{ m}} = -30 \text{ kN}$$

Solving $\begin{pmatrix} E_x \\ E_y \end{pmatrix} = \begin{pmatrix} -1 & 2 \\ 1 & 1 \end{pmatrix}^{-1} \begin{pmatrix} -35.858 \text{ kN} \\ -30 \text{ kN} \end{pmatrix} = \begin{pmatrix} -8.05 \\ -21.95 \end{pmatrix} \text{ kN}$

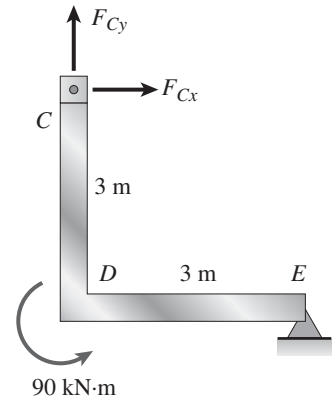

$$E_x = -8.05 \text{ kN} \quad E_y = -22 \text{ kN}$$

$$\Sigma F_x = 0 \quad A_x = -E_x + 10 \text{ kN} - 10 \text{ kN}\left(\frac{1}{\sqrt{2}}\right) = 10.98 \text{ kN} \quad A_x = 10.98 \text{ kN}$$

$$\Sigma F_y = 0 \quad A_y = -E_y + 10 \text{ kN}\left(\frac{1}{\sqrt{2}}\right) = 29.07 \text{ kN} \quad A_y = 29.1 \text{ kN}$$

(b) RIGHT HAND FBD $C_x = -E_x = 8.05 \text{ kN} \quad C_y = -E_y = 22 \text{ kN}$

$$\text{Resultant}_C = \sqrt{C_x^2 + C_y^2} = 23.4 \text{ kN}$$

Problem 1.2-17 A plane frame with pin supports at A and E has a cable attached at C , which runs over a frictionless pulley at F (see figure). The cable force is known to be 500 lb.

- (a) Find reactions at supports A and E .
- (b) Find internal stress resultants, N , V , and M at point H .

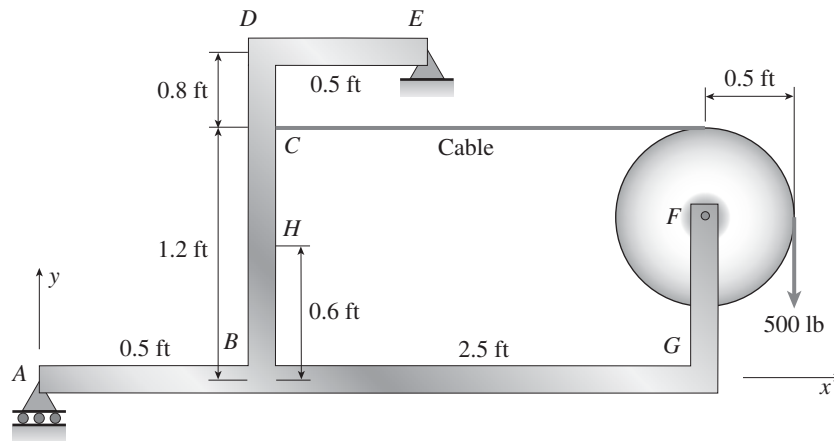

Solution 1.2-17

(a) STATICS

$$\Sigma F_x = 0 \quad E_x = 0$$

$$\Sigma M_E = 0 \quad A_y = \frac{1}{1 \text{ ft}}(-500 \text{ lb} \times 2.5 \text{ ft}) = -1250 \text{ lb}$$

$$\Sigma F_y = 0 \quad E_y = 500 \text{ lb} - A_y = 1750 \text{ lb}$$

(b) USE UPPER (SEE FIGURE BELOW) OR LOWER FBD TO FIND STRESS RESULTANTS N , V , AND M AT H

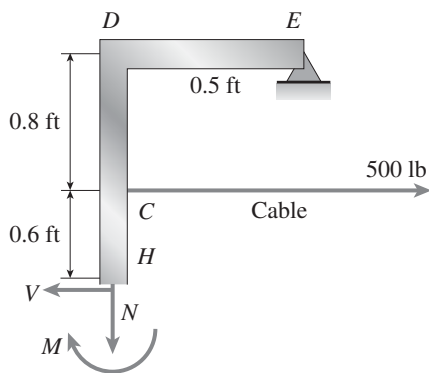

$$\Sigma F_x = 0 \quad V = E_x + 500 \text{ lb} = 500 \text{ lb}$$

$$\Sigma F_y = 0 \quad N = E_y = 1750 \text{ lb}$$

$$\Sigma M_H = 0$$

$$M = -0.6 \text{ ft}(500 \text{ lb}) - E_x 1.4 \text{ ft} + E_y 0.5 \text{ ft} = 575 \text{ lb-ft}$$

Problem 1.2-18 A plane frame with a pin support at A and roller supports at C and E has a cable attached at E , which runs over frictionless pulleys at D and B (see figure). The cable force is known to be 400 N. There is a pin connection just to the left of joint C .

- Find reactions at supports A , C , and E .
- Find internal stress resultants N , V , and M just to the right of joint C .
- Find resultant force in the pin near C .

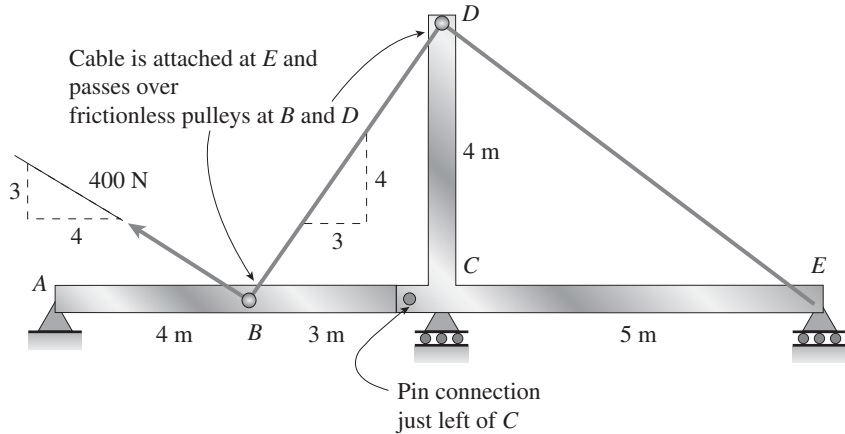

Solution 1.2-18

(a) STATICS

$$\sum F_x = 0 \quad A_x = \frac{4}{5}(400 \text{ N}) = 320 \text{ N} \quad \boxed{A_x = 320 \text{ N}}$$

Use left hand FBD (cut through pin just left of C)

$$\sum M_C = 0 \quad A_y = \frac{1}{7 \text{ m}} \left[\left[\frac{-3}{5}(400 \text{ N}) - \frac{4}{5}(400 \text{ N}) \right] (3 \text{ m}) \right] = -240 \text{ N} \quad \boxed{A_y = -240 \text{ N}}$$

Use entire FBD $\sum M_C = 0 \quad E_y = \frac{1}{5 \text{ m}} \left[A_y(7 \text{ m}) + \left(\frac{3}{5} 400 \text{ N} \right) (3 \text{ m}) \right] = -192 \text{ N} \quad \boxed{E_y = -192 \text{ N}}$

$$\sum F_y = 0 \quad C_y = -A_y - E_y - \frac{3}{5}(400 \text{ N}) = 192 \text{ N} \quad \boxed{C_y = 192 \text{ N}}$$

(b) N , V , AND M JUST RIGHT OF C ; USE RIGHT HAND FBD

$$F_{\text{cable}X} = 400 \text{ N} \left(\frac{5}{\sqrt{4^2 + 5^2}} \right) = 312.348 \text{ N}$$

$$F_{\text{cable}Y} = \frac{4}{5} F_{\text{cable}X} = 249.878 \text{ N}$$

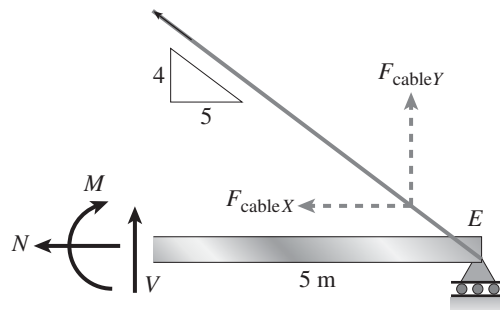

$$\sum F_x = 0 \quad \boxed{N_x = -F_{\text{cable}X} = -312 \text{ N}}$$

$$\sum F_y = 0 \quad \boxed{V = -F_{\text{cable}Y} - E_y = -57.9 \text{ N}}$$

$$\sum M_C = 0 \quad M = (F_{\text{cable}Y} + E_y)(5 \text{ m}) = \boxed{289 \text{ N}\cdot\text{m}}$$

(c) RESULTANT FORCE IN PIN JUST LEFT OF C ; USE LEFT HAND FBD $A_x = 320 \text{ N}$

$$F_{Cx} = -A_x + \left(\frac{4}{5} - \frac{3}{5} \right) 400 \text{ N} = -240 \text{ N} \quad F_{Cy} = -A_y - \left(\frac{3}{5} + \frac{4}{5} \right) 400 \text{ N} = -320 \text{ N}$$

$$\boxed{\text{Res}_C = \sqrt{F_{Cx}^2 + F_{Cy}^2} = 400 \text{ N}}$$

Problem 1.2-19 A 150-lb rigid bar AB , with frictionless rollers at each end, is held in the position shown in the figure by a continuous cable CAD . The cable is pinned at C and D and runs over a pulley at A .

- (a) Find reactions at supports A and B .
- (b) Find the force in the cable.

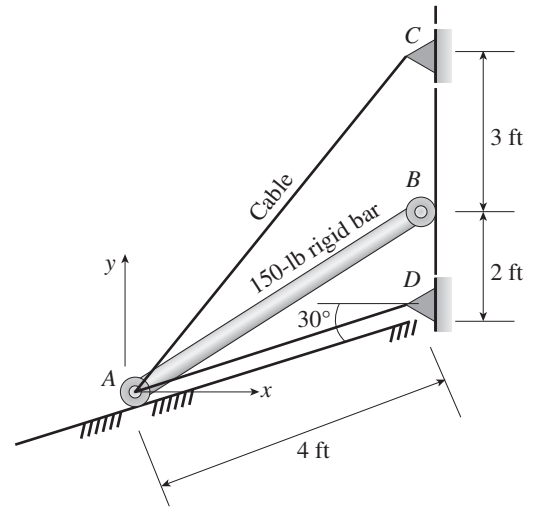

Solution 1.2-19

(a) STATICS $W = 150$ lb

$$\sum M_A = 0 \quad B_x(4) + W\left(\frac{2\sqrt{3}}{2}\right) = 0 \text{ solve, } B_x = -\frac{75\sqrt{3}}{2}$$

$$\text{so } B_x = -\frac{75\sqrt{3}}{2} = -64.952$$

$$\sum F_x = 0 \quad -A \sin(30^\circ) + B_x + T \cos(30^\circ) + T \cos\left(\arctan\left(\frac{7}{2\sqrt{3}}\right)\right) = 0$$

$$\sum F_y = 0 \quad A \cos(30^\circ) + T \sin(30^\circ) + T \sin\left(\arctan\left(\frac{7}{2\sqrt{3}}\right)\right) = W$$

$$\begin{pmatrix} A \\ T \end{pmatrix} = \begin{pmatrix} -\sin(30^\circ) & \cos(30^\circ) + \cos\left(\arctan\left(\frac{7}{2\sqrt{3}}\right)\right) \\ \cos(30^\circ) & \sin(30^\circ) + \sin\left(\arctan\left(\frac{7}{2\sqrt{3}}\right)\right) \end{pmatrix}^{-1} \begin{pmatrix} -B_x \\ W \end{pmatrix} \quad \begin{pmatrix} A \\ T \end{pmatrix} = \begin{pmatrix} 57.713 \\ 71.634 \end{pmatrix} \text{ lb}$$

SUPPORT REACTIONS

$$\boxed{B_x = -65} \quad \boxed{A = 57.7} \quad \text{Units} = \text{lbs}$$

$$A_x = -A \sin(30^\circ) = -28.9 \text{ lb} \quad A_y = A \cos(30^\circ) = 50 \text{ lb}$$

$$\sqrt{A_x^2 + A_y^2} = 57.713$$

(b) CABLE FORCE IS T (LBS) FROM ABOVE SOLUTION

$$\boxed{T = 71.6 \text{ lb}}$$

Problem 1.2-20 A plane frame has a pin support at A and roller supports at C and E (see figure). Frame segments ABD and $CDEF$ are joined just left of joint D by a pin connection.

- Find reactions at supports A , C , and E .
- Find the resultant force in the pin just left of D .

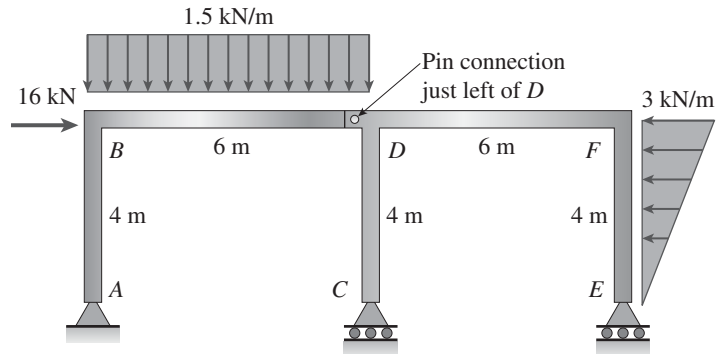

Solution 1.2-20

(a) STATICS

RIGHT-HAND FBD

$$\Sigma M_{\text{pin}} = 0 \quad E_y = \frac{1}{6 \text{ m}} \left[\frac{1}{2} (3 \text{ kN/m}) 4 \text{ m} \left(\frac{1}{3} 4 \text{ m} \right) \right] = 1.333 \text{ kN} \quad \boxed{E_y = 1.333 \text{ kN}}$$

ENTIRE FBD

$$\Sigma M_A = 0 \quad C_y = \frac{1}{6 \text{ m}} \left[-E_y 12 \text{ m} + (16 \text{ kN}) 4 \text{ m} + (1.5 \text{ kN/m}) 6 \text{ m} (3 \text{ m}) - \frac{1}{2} (3 \text{ kN/m}) 4 \text{ m} \left(\frac{2}{3} 4 \text{ m} \right) \right] = 9.833 \text{ kN}$$

$$\boxed{C_y = 9.83 \text{ kN}}$$

$$\Sigma F_y = 0 \quad A_y = -C_y - E_y + (1.5 \text{ kN/m}) 6 \text{ m} = -2.167 \text{ kN} \quad \boxed{A_y = -2.17 \text{ kN}}$$

$$\Sigma F_x = 0 \quad A_x = -16 \text{ kN} + \frac{1}{2} (3 \text{ kN/m}) 4 \text{ m} = -10 \text{ kN} \quad \boxed{A_x = -10 \text{ kN}}$$

(b) RESULTANT FORCE IN PIN; USE EITHER RIGHT HAND OR LEFT HAND FBD (CUT THROUGH PIN EXPOSING PIN FORCES F_{Dx} AND F_{Dy}) THEN SUM FORCES IN x AND y DIRECTIONS FOR EITHER FBD

LHFB:

$$F_{Dx} = -16 \text{ kN} - A_x = -6 \text{ kN}$$

$$F_{Dy} = -A_y + (1.5 \text{ kN/m}) 6 \text{ m} = 11.167 \text{ kN}$$

$$\text{Resultant}_D = \sqrt{F_{Dx}^2 + F_{Dy}^2} = 12.68 \text{ kN}$$

RHFB:

$$F_{Dx} = \frac{1}{2} (3 \text{ kN/m}) 4 \text{ m} = 6 \text{ kN}$$

$$F_{Dy} = -C_y - E_y = -11.167 \text{ kN}$$

$$\boxed{\text{Resultant}_D = 12.68 \text{ kN}}$$

Problem 1.2-21 A special vehicle brake is clamped at O , (when the brake force P_1 is applied—see figure). Force $P_1 = 50$ lb and lies in a plane which is parallel to the xz plane and is applied at C normal to line BC . Force $P_2 = 40$ lb and is applied at B in the $-y$ direction.

- (a) Find reactions at support O .
- (b) Find internal stress resultants N , V , T , and M at the midpoint of segment OA .

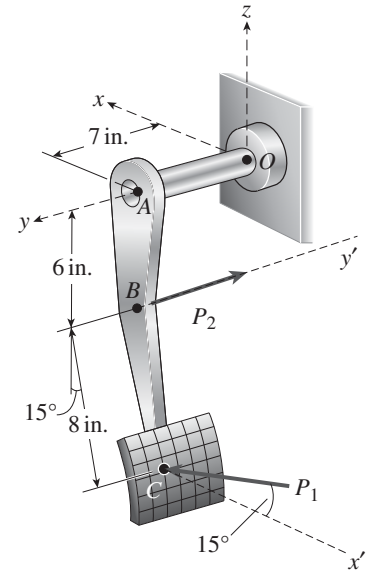

Solution 1.2-21

(a) STATICS $P_1 = 50$ lb $P_2 = 40$ lb

$$\Sigma F_x = 0 \quad O_x = -P_1 \cos(15^\circ) = -48.3 \text{ lb} \quad \Sigma F_y = 0 \quad O_y = P_2 = 40 \text{ lb}$$

$$\Sigma F_z = 0 \quad O_z = P_1 \sin(15^\circ) = 12.94 \text{ lb}$$

$$\Sigma M_x = 0 \quad M_{Ox} = P_2(6 \text{ in.}) + P_1 \sin(15^\circ)(7 \text{ in.}) = 331 \text{ lb-in.}$$

$$\Sigma M_y = 0 \quad M_{Oy} = P_1 \sin(15^\circ)(8 \text{ in.} \sin(15^\circ)) + P_1 \cos(15^\circ)(6 \text{ in.} + 8 \text{ in.} \cos(15^\circ))$$

$$M_{Oy} = 690 \text{ lb-in.}$$

$$\Sigma M_z = 0 \quad M_{Oz} = -P_1 \cos(15^\circ)(7 \text{ in.}) = -338 \text{ lb-in.}$$

- (b) INTERNAL STRESS RESULTANTS AT MIDPOINT OF OA

$$N = -O_y = -40 \text{ lb}$$

$$V_x = -O_x = 48.3 \text{ lb} \quad V_z = -O_z = -12.94 \text{ lb} \quad V = \sqrt{V_x^2 + V_z^2} = 50 \text{ lb}$$

$$T = -M_{Oy} = -690 \text{ lb-in.}$$

$$M_x = -M_{Ox} = -330.59 \text{ lb-in.} \quad M_z = -M_{Oz} = 338.07 \text{ lb-in.} \quad M = \sqrt{M_x^2 + M_z^2} = 473 \text{ lb-in.}$$

Problem 1.2-22 Space frame $ABCD$ is clamped at A , except it is free to translate in the x -direction. There is also a roller support at D , which is normal to line CDE . A triangularly distributed force with peak intensity $q_0 = 75 \text{ N/m}$ acts along AB in the positive z direction. Forces $P_x = 60 \text{ N}$ and $P_z = -45 \text{ N}$ are applied at joint C and a concentrated moment $M_y = 120 \text{ N}\cdot\text{m}$ acts at the mid-span of member BC .

- (a) Find reactions at supports A and D .
 (b) Find internal stress resultants N , V , T , and M at the mid-height of segment AB .

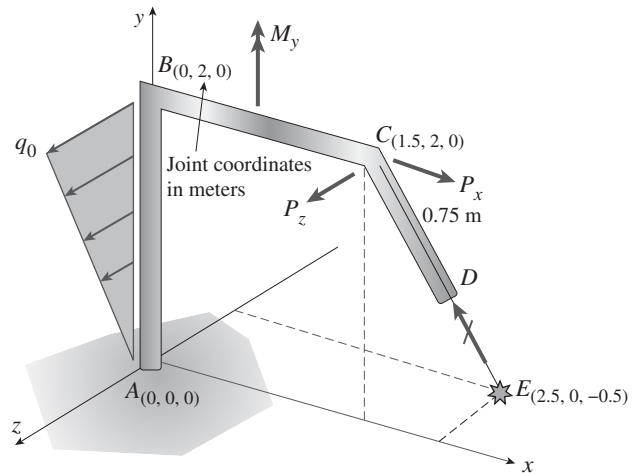

Solution 1.2-22

FORCES

$$P_x = 60 \text{ N} \quad P_z = -45 \text{ N} \quad M_y = 120 \text{ N}\cdot\text{m} \quad q_0 = 75 \text{ N/m}$$

$$F_C = \begin{pmatrix} P_x \\ 0 \\ P_z \end{pmatrix} = \begin{pmatrix} 60 \\ 0 \\ -45 \end{pmatrix} \text{ N} \quad R_A = \begin{pmatrix} 0 \\ A_y \\ A_z \end{pmatrix}$$

VECTOR ALONG MEMBER CD

$$r_{EC} = \begin{bmatrix} 1.5 - 2.5 \\ 2 - 0 \\ 0 - (-0.5) \end{bmatrix} = \begin{bmatrix} -1 \\ 2 \\ 0.5 \end{bmatrix} \quad |r_{EC}| = 2.291 \quad e_{EC} = \frac{r_{EC}}{|r_{EC}|} = \begin{pmatrix} -0.436 \\ 0.873 \\ 0.218 \end{pmatrix}$$

(a) STATICS (FORCE AND MOMENT EQUILIBRIUM)

$$\Sigma F = 0 \quad \begin{pmatrix} 0 \\ A_y \\ A_z \end{pmatrix} + \begin{pmatrix} 0 \\ 0 \\ R_T \end{pmatrix} + \begin{pmatrix} P_x \\ 0 \\ P_z \end{pmatrix} + \begin{pmatrix} D_x \\ D_y \\ D_z \end{pmatrix} = 0 \quad \text{resultant of triangular load: } R_T = \frac{1}{2} q_0 (2 \text{ m}) = 75 \text{ N}$$

$$\text{where } \begin{pmatrix} D_x \\ D_y \\ D_z \end{pmatrix} = D e_{EC}$$

SOLVING ABOVE THREE EQUATIONS:

$$\Sigma F_x = 0 \quad D_x = -P_x \quad \text{so} \quad D = \frac{-P_x}{e_{EC1}}$$

$$D = 137.477 \text{ N} \quad \boxed{D_x = -60 \text{ N}}$$

$$\Sigma F_y = 0 \quad D_y = e_{EC2} D$$

$$\boxed{D_y = 120 \text{ N}}$$

$$\boxed{A_y = -D_y = -120 \text{ N}}$$

$$\Sigma F_z = 0 \quad D_z = e_{EC3} D$$

$$\boxed{D_z = 30 \text{ N}}$$

$$\sqrt{D_x^2 + D_y^2 + D_z^2} = 137.477 \text{ N}$$

$$\text{so } A_z = -D_z - R_T - P_z$$

$$\boxed{A_z = -60 \text{ N}}$$

$$\Sigma M_A = 0$$

$$\begin{pmatrix} M_{Ax} \\ M_{Ay} \\ M_{Az} \end{pmatrix} + r_{AE} \times D + r_{AC} \times \begin{pmatrix} P_x \\ 0 \\ P_z \end{pmatrix} + \begin{pmatrix} 0 \\ M_y \\ 0 \end{pmatrix} + r_{cg} \times \begin{pmatrix} 0 \\ 0 \\ R_T \end{pmatrix} = 0$$

$$r_{AE} = \begin{pmatrix} 2.5 - 0 \\ 0 - 0 \\ -0.5 - 0 \end{pmatrix} \text{ m} \quad D = \begin{pmatrix} D_x \\ D_y \\ D_z \end{pmatrix} \quad D = \begin{pmatrix} -60 \\ 120 \\ 30 \end{pmatrix} \text{ N} \quad |D| = 137.477 \text{ N} \quad r_{AE} \times D = \begin{pmatrix} 60 \\ -45 \\ 300 \end{pmatrix} \text{ N}\cdot\text{m}$$

$$r_{AC} = \begin{pmatrix} 1.5 - 0 \\ 2 - 0 \\ 0 - 0 \end{pmatrix} \text{ m} \quad r_{AC} \times \begin{pmatrix} P_x \\ 0 \\ P_z \end{pmatrix} = \begin{pmatrix} -90 \\ 67.5 \\ -120 \end{pmatrix} \text{ J} \quad r_{cg} = \begin{pmatrix} 0 \\ \frac{2}{3}(2 \text{ m}) \\ 0 \end{pmatrix} \quad r_{cg} \times \begin{pmatrix} 0 \\ 0 \\ R_T \end{pmatrix} = \begin{pmatrix} 100 \\ 0 \\ 0 \end{pmatrix} \text{ N}\cdot\text{m}$$

$$\begin{pmatrix} M_{Ax} \\ M_{Ay} \\ M_{Az} \end{pmatrix} = - \left[r_{AE} \times D + r_{AC} \times \begin{pmatrix} P_x \\ 0 \\ P_z \end{pmatrix} + \begin{pmatrix} 0 \\ M_y \\ 0 \end{pmatrix} + r_{cg} \times \begin{pmatrix} 0 \\ 0 \\ R_T \end{pmatrix} \right] = \begin{pmatrix} -70 \\ -142.5 \\ -180 \end{pmatrix} \text{ N}\cdot\text{m} \quad \boxed{\begin{pmatrix} M_{Ax} \\ M_{Ay} \\ M_{Az} \end{pmatrix} = \begin{pmatrix} -70 \\ -142.5 \\ -80 \end{pmatrix} \text{ N}\cdot\text{m}}$$

(b) RESULTANTS AT MID-HEIGHT OF AB (SEE FBD IN FIGURE BELOW)

$$\boxed{N = -A_y = 120 \text{ N}} \quad V_x = -D_x - P_x = 0 \text{ N} \quad V_z = -A_z - \frac{1}{2} \frac{q_0}{2} (2\text{m})/2 = 41.25 \text{ N} \quad \boxed{V = V_z = 41.3 \text{ N}}$$

$$\boxed{T = -M_{Ay} = 142.5 \text{ N}\cdot\text{m}} \quad M_x = -M_{Ax} + A_z(1 \text{ m}) + \frac{1}{2} \frac{q_0}{2} 1 \text{ m} \left(\frac{1}{3} 1 \text{ m} \right) = 16.25 \text{ N}\cdot\text{m}$$

$$M_z = -M_{Az} = 180 \text{ N}\cdot\text{m}$$

$$M_{\text{resultant}} = \sqrt{M_x^2 + M_z^2} = 180.732 \text{ N}\cdot\text{m}$$

$$\boxed{M_{\text{resultant}} = 180.7 \text{ N}\cdot\text{m}}$$

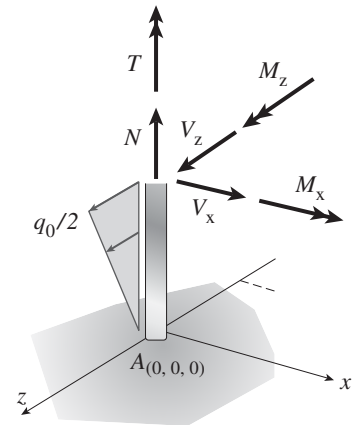

Problem 1.2-23 Space frame ABC is clamped at A except it is free to rotate at A about the x and y axes. Cables DC and EC support the frame at C . Forces $P_y = -50$ lb is applied at mid-span of AB and a concentrated moment $M_x = -20$ in-lb acts at joint B .

- (a) Find reactions at supports A .
 (b) Find cable tension forces.

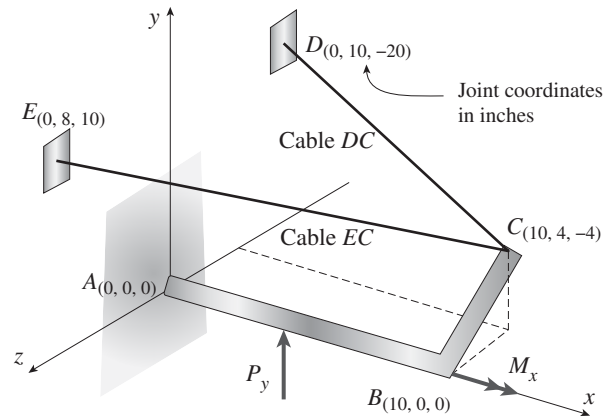

Solution 1.2-23

POSITION AND UNIT VECTORS

$$r_{AB} = \begin{pmatrix} 10 \\ 0 \\ 0 \end{pmatrix} \quad r_{AP} = \begin{pmatrix} 5 \\ 0 \\ 0 \end{pmatrix} \quad r_{AC} = \begin{pmatrix} 10 \\ 4 \\ -4 \end{pmatrix} \quad r_{CD} = \begin{bmatrix} 0 - 10 \\ 10 - 4 \\ -20 - (-4) \end{bmatrix} = \begin{pmatrix} -10 \\ 6 \\ -16 \end{pmatrix} \quad e_{CD} = \frac{r_{CD}}{|r_{CD}|} = \begin{pmatrix} -0.505 \\ 0.303 \\ -0.808 \end{pmatrix}$$

APPLIED FORCE AND MOMENT

$$r_{CE} = \begin{bmatrix} 0 - 10 \\ 8 - 4 \\ 10 - (-4) \end{bmatrix} = \begin{pmatrix} -10 \\ 4 \\ 14 \end{pmatrix} \quad e_{CE} = \frac{r_{CE}}{|r_{CE}|} = \begin{pmatrix} -0.566 \\ 0.226 \\ 0.793 \end{pmatrix}$$

$$P_y = -50 \text{ lb} \quad M_x = -20 \text{ lb-in.}$$

STATICS FORCE AND MOMENT EQUILIBRIUM

First sum moment about point A

$$\sum M_A = 0$$

$$M_A = \begin{pmatrix} 0 \\ 0 \\ M_{Az} \end{pmatrix} + r_{AP} \times \begin{pmatrix} 0 \\ P_y \\ 0 \end{pmatrix} + \begin{pmatrix} M_x \\ 0 \\ 0 \end{pmatrix} + r_{AC} \times (T_D e_{CD} + T_E e_{CE}) = \begin{pmatrix} -2.0203 T_D + 4.0762 T_E - 20.0 \\ 10.102 T_D + -5.6614 T_E \\ M_{Az} + 5.0508 T_D + 4.5291 T_E - 250.0 \end{pmatrix}$$

Solve moment equilibrium equations for moments about x and y axes to get cable tension forces

$$\begin{pmatrix} T_D \\ T_E \end{pmatrix} = \begin{pmatrix} -2.0203 & 4.0762 \\ 10.102 & -5.6614 \end{pmatrix}^{-1} \begin{pmatrix} 20 \\ 0 \end{pmatrix} = \begin{pmatrix} 3.81 \\ 6.79 \end{pmatrix} \text{ lb} \quad (\text{b})$$

Next, solve moment equilibrium equation about z axis now that cable forces are known

$$M_{Az} = -(5.0508 T_D + 4.5291 T_E - 250.0) = 200 \text{ lb-in.} \quad (\text{a})$$

Finally, use force equilibrium to find reaction forces at point A

$$\sum F = 0 \quad \begin{pmatrix} A_x \\ A_y \\ A_z \end{pmatrix} = - \begin{pmatrix} 0 \\ P_y \\ 0 \end{pmatrix} - (T_D e_{CD} + T_E e_{CE}) = \begin{pmatrix} 5.77 \\ 47.31 \\ -2.31 \end{pmatrix} \text{ lb}$$

Problem 1.2-24 A soccer goal is subjected to gravity loads (in the $-z$ direction, $w = 73 \text{ N/m}$ for DG , BG , and BC ; $w = 29 \text{ N/m}$ for all other members; see figure) and a force $F = 200 \text{ N}$ applied eccentrically at mid-height of member DG . Find reactions at supports C , D , and H .

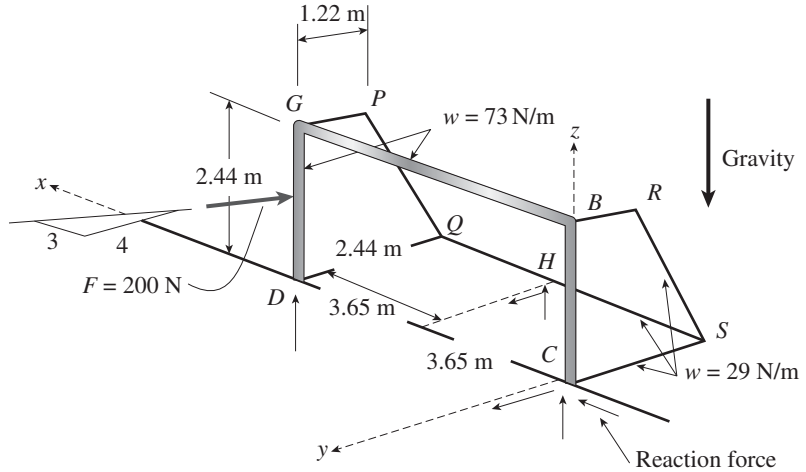

Solution 1.2-24

FIND MEMBER LENGTHS

$$L_{QS} = 2(3.65 \text{ m}) = 7.3 \text{ m} \quad L_{RS} = \sqrt{(2.44 \text{ m})^2 + (2.44 \text{ m} - 1.22 \text{ m})^2} = 2.728 \text{ m} \quad L_{PQ} = L_{RS}$$

Assume that soccer goal is supported only at points C , H , and D (see reaction force components in figure)

STATICS SUM MOMENT ABOUT EACH AXIS AND FORCES IN EACH AXIS DIRECTION $F = 200 \text{ N}$

$\Sigma M_x = 0$ TO FIND REACTION COMPONENT H_y :

Find moments about x due to for component F_y and also for distributed weight of each frame component

$$M_{xGP} = \frac{(1.22 \text{ m})^2}{2} (29 \text{ N/m}) \quad M_{xBR} = M_{xGP} \quad M_{xDQ} = \frac{(2.44 \text{ m})^2}{2} (29 \text{ N/m}) \quad M_{xCS} = M_{xDQ}$$

$$M_{xRS} = L_{RS}(29 \text{ N/m}) \left(1.22 \text{ m} + \frac{1.22 \text{ m}}{2} \right) \quad M_{xPQ} = M_{xRS} \quad M_{xQS} = L_{QS}(29 \text{ N/m})(2.44 \text{ m})$$

$$H_z = \frac{1}{2.44 \text{ m}} \left[\frac{4}{5} F \left(\frac{2.44 \text{ m}}{2} \right) + 2M_{xGP} + 2M_{xDQ} + 2M_{xPQ} + M_{xQS} \right] = 498.818 \text{ N} \quad \boxed{H_z = 499 \text{ N}}$$

$\Sigma M_y = 0$ TO FIND REACTION FORCE D_z :

$$M_{yGD} = 2.44 \text{ m} (73 \text{ N/m}) L_{QS} \quad M_{yGP} = 1.22 \text{ m} (29 \text{ N/m}) L_{QS} \quad M_{yDQ} = 2.44 \text{ m} (29 \text{ N/m}) L_{QS}$$

$$M_{yPQ} = L_{RS}(29 \text{ N/m}) L_{QS} \quad M_{yBG} = L_{QS}(73 \text{ N/m}) \frac{L_{QS}}{2} \quad M_{yQS} = L_{QS}(29 \text{ N/m}) \frac{L_{QS}}{2}$$

$$D_z = \frac{1}{L_{QS}} \left[M_{yGD} + M_{yGP} + M_{yDQ} + M_{yPQ} + M_{yBG} + M_{yQS} - H_z \frac{L_{QS}}{2} - \frac{3}{5} F \left(\frac{2.44 \text{ m}}{2} \right) \right] = 466.208 \text{ N}$$

$$\boxed{D_z = 466 \text{ N}}$$

$\Sigma M_z = 0$ TO FIND REACTION FORCE H_y :

$$H_y = \frac{1}{3.65 \text{ m}} \left(\frac{4}{5} F L_{QS} \right) = 320 \text{ N} \quad \boxed{H_y = 320 \text{ N}}$$

$$\Sigma F_x = 0 \text{ TO FIND REACTION FORCE } C_x: \quad C_x = \frac{3}{5}F = 120 \text{ N}$$

$$\Sigma F_y = 0 \text{ TO FIND REACTION FORCE } C_y: \quad C_y = -H_y + \frac{4}{5}F = -160 \text{ N} \quad C_y = -160 \text{ N}$$

$$\Sigma F_z = 0 \text{ TO FIND REACTION FORCE } C_z:$$

$$C_z = -D_z - H_z + (29 \text{ N/m})(21.22 \text{ m} + 22.44 \text{ m} + 2L_{RS} + L_{QS}) \\ + (73 \text{ N/m})(22.44 \text{ m} + L_{QS}) = 506.318 \text{ N} \quad C_z = 506 \text{ N}$$

Problem 1.2-25 An elliptical exerciser machine (see figure part a) is composed of front and back rails. A simplified plane frame model of the back rail is shown in figure part b. Analyze the plane frame model to find reaction forces at supports A, B, and C for the position and applied loads given in figure part b. Note that there are axial and moment releases at the base of member 2 so that member 2 can lengthen and shorten as the roller support at B moves along the 30° incline. (These releases indicate that the internal axial force N and moment M must be zero at this location.)

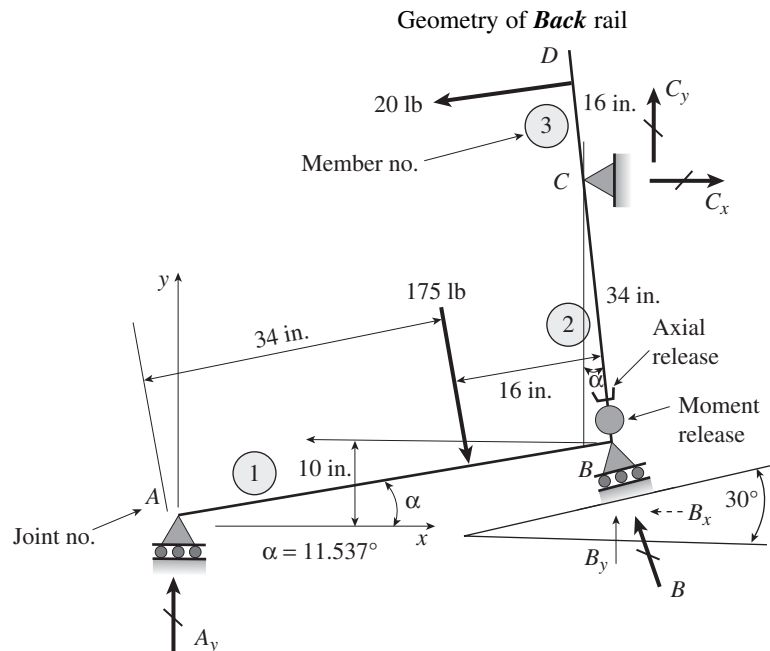

Solution 1.2-25

$$\alpha = \arcsin\left(\frac{10}{50}\right) = 11.537^\circ \quad \text{Analysis pertains to this position of exerciser only}$$

STATICS UFBFD (CUT AT AXIAL AND MOMENT RELEASES JUST ABOVE B)

Inclined vertical component of reaction at C = 0 (due to axial release)

Sum moments about moment release to get inclined normal reaction at C

$$C = \frac{20 \text{ lb}(34 \text{ in.} + 16 \text{ in.})}{34 \text{ in.}} = 29.412 \text{ lb} \quad C_x = C \cos(\alpha) = 28.8 \text{ lb}$$

$$C_y = C \sin(\alpha) = 5.88 \text{ lb} \quad \sqrt{C_x^2 + C_y^2} = 29.412 \text{ lb}$$

STATICS LFBFD (CUT THROUGH AXIAL AND MOMENT RELEASES)

Sum moments to find reaction A_y

$$A_y = \frac{175 \text{ lb}(16 \text{ in.})}{(34 \text{ in.} + 16 \text{ in.}) \cos(\alpha)} = 57.2 \text{ lb}$$

STATICS SUM FORCES FOR ENTIRE FBD TO FIND REACTION AT *B*

Sum forces in *x*-direction: $B_x = C_x + 175\text{lb}(\sin(\alpha)) - 20\text{lb}(\cos(\alpha)) = 44.2\text{lb} <$ acts leftward

Sum forces in *y*-direction: $B_y = -A_y - C_y + 175\text{lb}(\cos(\alpha)) + 20\text{lb}(\sin(\alpha)) = 112.4\text{lb}$

$B_x = 44.2\text{ lb}$ $B_y = 112.4\text{ lb}$

Resultant reaction force at *B*: $B = \sqrt{B_x^2 + B_y^2} = 120.8\text{ lb}$

Problem 1.2-26 A mountain bike is moving along a flat path at constant velocity. At some instant, the rider (weight = 670 N) applies pedal and hand forces, as shown in the figure part a.

- (a) Find reactions forces at the front and rear hubs. (Assume that the bike is pin supported at the rear hub and roller supported at the front hub).
- (b) Find internal stress resultants *N*, *V*, and *M* in the inclined seat post (see figure part b).

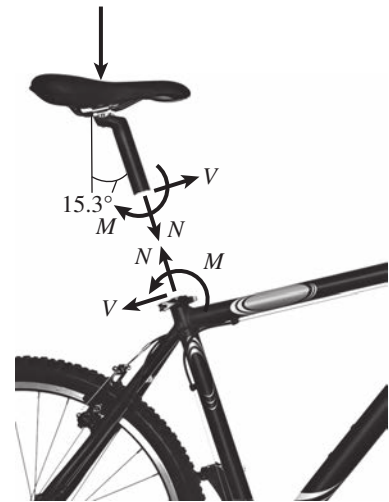

Solution 1.2-26

(a) REACTIONS: SUM MOMENTS ABOUT REAR HUB TO FIND VERTICAL REACTION AT FRONT HUB (FIG. 1)

$$\Sigma M_B = 0$$

$$V_F = \frac{1}{1130} [670(241) - 90(\cos(5^\circ))254 + 200\cos(15^\circ)660 + 2(45)\cos(30^\circ)1021 + 2(45)\sin(30^\circ)752]$$

$$V_F = 335.945\text{ N}$$

Sum forces to get force components at rear hub

$$\Sigma F_{\text{vert}} = 0 \quad V_B = 670 - 90 \cos(5^\circ) + 200 \cos(15^\circ) + 2(45) \cos(30^\circ) - V_F = 515.525 \text{ N}$$

$$\Sigma F_{\text{horiz}} = 0 \quad H_B = -90 \sin(5^\circ) - 200 \sin(15^\circ) - 2(45) \sin(30^\circ) = -104.608 \text{ N}$$

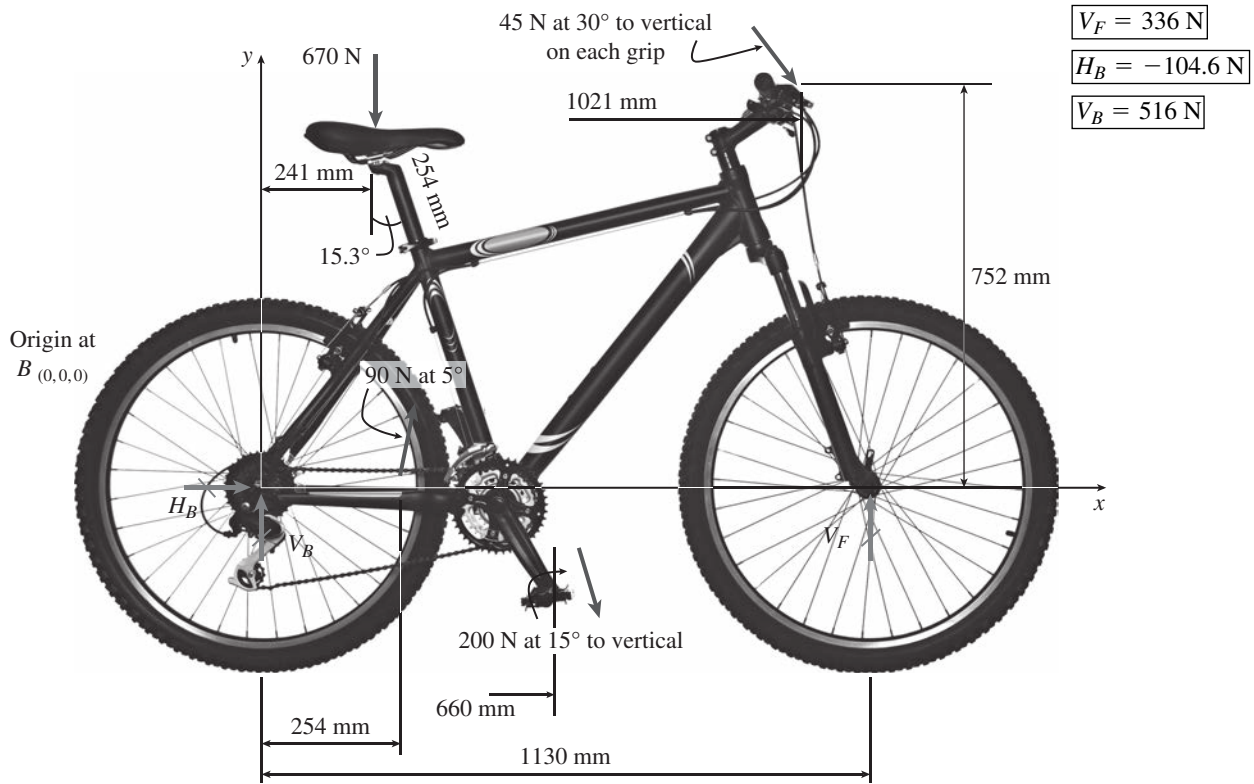

(b) STRESS RESULTANTS N , V , AND M IN SEAT POST (Fig. 2)

SEAT POST RESULTANTS (FIG. 2)

$$N = -670 \cos(15.3^\circ) = -646.253 \text{ N}$$

$$N = -646 \text{ N}$$

$$V = 670 \sin(15.3^\circ) = 176.795 \text{ N}$$

$$V = 176.8 \text{ N}$$

$$M = 670 \sin(15.3^\circ) 254 = 44,905.916 \text{ N}\cdot\text{mm}$$

$$M = 44.9 \text{ N}\cdot\text{m}$$

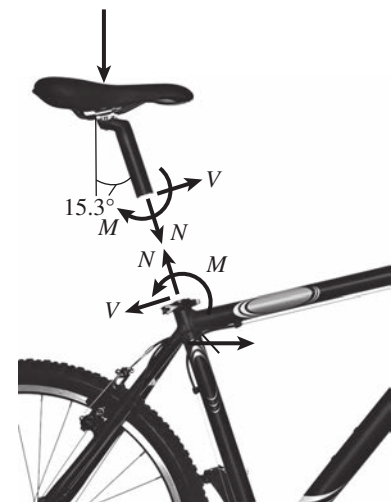

Normal Stress and Strain

Problem 1.3-1 A hollow circular post *ABC* (see figure) supports a load $P_1 = 1700$ lb acting at the top. A second load P_2 is uniformly distributed around the cap plate at *B*. The diameters and thicknesses of the upper and lower parts of the post are $d_{AB} = 1.25$ in., $t_{AB} = 0.5$ in., $d_{BC} = 2.25$ in., and $t_{BC} = 0.375$ in., respectively.

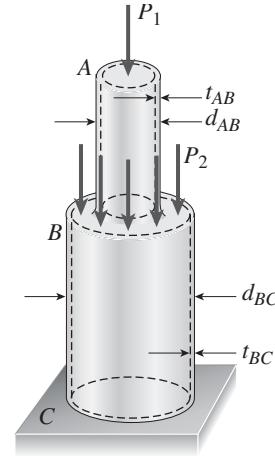

- (a) Calculate the normal stress σ_{AB} in the upper part of the post.
- (b) If it is desired that the lower part of the post have the same compressive stress as the upper part, what should be the magnitude of the load P_2 ?
- (c) If P_1 remains at 1700 lb and P_2 is now set at 2260 lb, what new thickness of *BC* will result in the same compressive stress in both parts?

Solution 1.3-1

PART (a)

$$P_1 = 1700 \text{ lb} \quad d_{AB} = 1.25 \text{ in.} \quad t_{AB} = 0.5 \text{ in.}$$

$$d_{BC} = 2.25 \text{ in.} \quad t_{BC} = 0.375 \text{ in.}$$

$$A_{AB} = \frac{\pi [d_{AB}^2 - (d_{AB} - 2t_{AB})^2]}{4}$$

$$A_{AB} = 1.178 \text{ in.}^2 \quad \sigma_{AB} = \frac{P_1}{A_{AB}}$$

$$\sigma_{AB} = 1443 \text{ psi} \quad \leftarrow$$

PART (c)

$$P_2 = 2260 \quad \frac{P_1 + P_2}{\sigma_{AB}} = A_{BC}$$

$$\frac{P_1 + P_2}{\sigma_{AB}} = 2.744$$

$$(d_{BC} - 2t_{BC})^2 = d_{BC}^2 - \frac{4}{\pi} \left(\frac{P_1 + P_2}{\sigma_{AB}} \right)$$

PART (b)

$$A_{BC} = \frac{\pi [d_{BC}^2 - (d_{BC} - 2t_{BC})^2]}{4}$$

$$A_{BC} = 2.209 \text{ in.}^2 \quad P_2 = \sigma_{AB} A_{BC} - P_1$$

$$P_2 = 1488 \text{ lbs} \quad \leftarrow$$

CHECK: $\frac{P_1 + P_2}{A_{BC}} = 1443 \text{ psi}$

$$d_{BC} - 2t_{BC} = \sqrt{d_{BC}^2 - \frac{4}{\pi} \left(\frac{P_1 + P_2}{\sigma_{AB}} \right)}$$

$$t_{BC} = \frac{d_{BC} - \sqrt{d_{BC}^2 - \frac{4}{\pi} \left(\frac{P_1 + P_2}{\sigma_{AB}} \right)}}{2}$$

$$t_{BC} = 0.499 \text{ in.} \quad \leftarrow$$

Problem 1.3-2 A force P of 70 N is applied by a rider to the front hand brake of a bicycle (P is the resultant of an evenly distributed pressure). As the hand brake pivots at A , a tension T develops in the 460-mm long brake cable ($A_e = 1.075 \text{ mm}^2$) which elongates by $\delta = 0.214 \text{ mm}$. Find normal stress σ and strain ε in the brake cable.

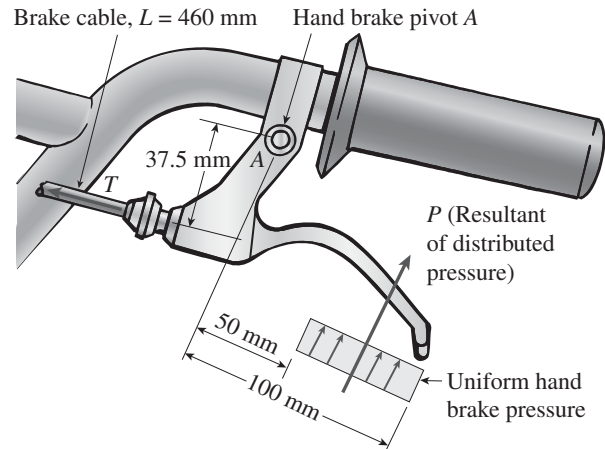

Solution 1.3-2

$$P = 70 \text{ N} \quad A_e = 1.075 \text{ mm}^2$$

$$L = 460 \text{ mm} \quad \delta = 0.214 \text{ mm}$$

Statics: sum moments about A to get $T = 2P$

$$\sigma = \frac{T}{A_e} \quad \sigma = 103.2 \text{ MPa} \quad \leftarrow$$

$$\varepsilon = \frac{\delta}{L} \quad \varepsilon = 4.65 \times 10^{-4} \quad \leftarrow$$

$$E = \frac{\sigma}{\varepsilon} = 1.4 \times 10^5 \text{ MPa}$$

NOTE: (E for cables is approximately 140 GPa)