

CHAPTER 1

MECHANISMS

1.1 Determine the degree of freedom for the linkages in Figure P1.1, which of these linkages represents mechanisms.

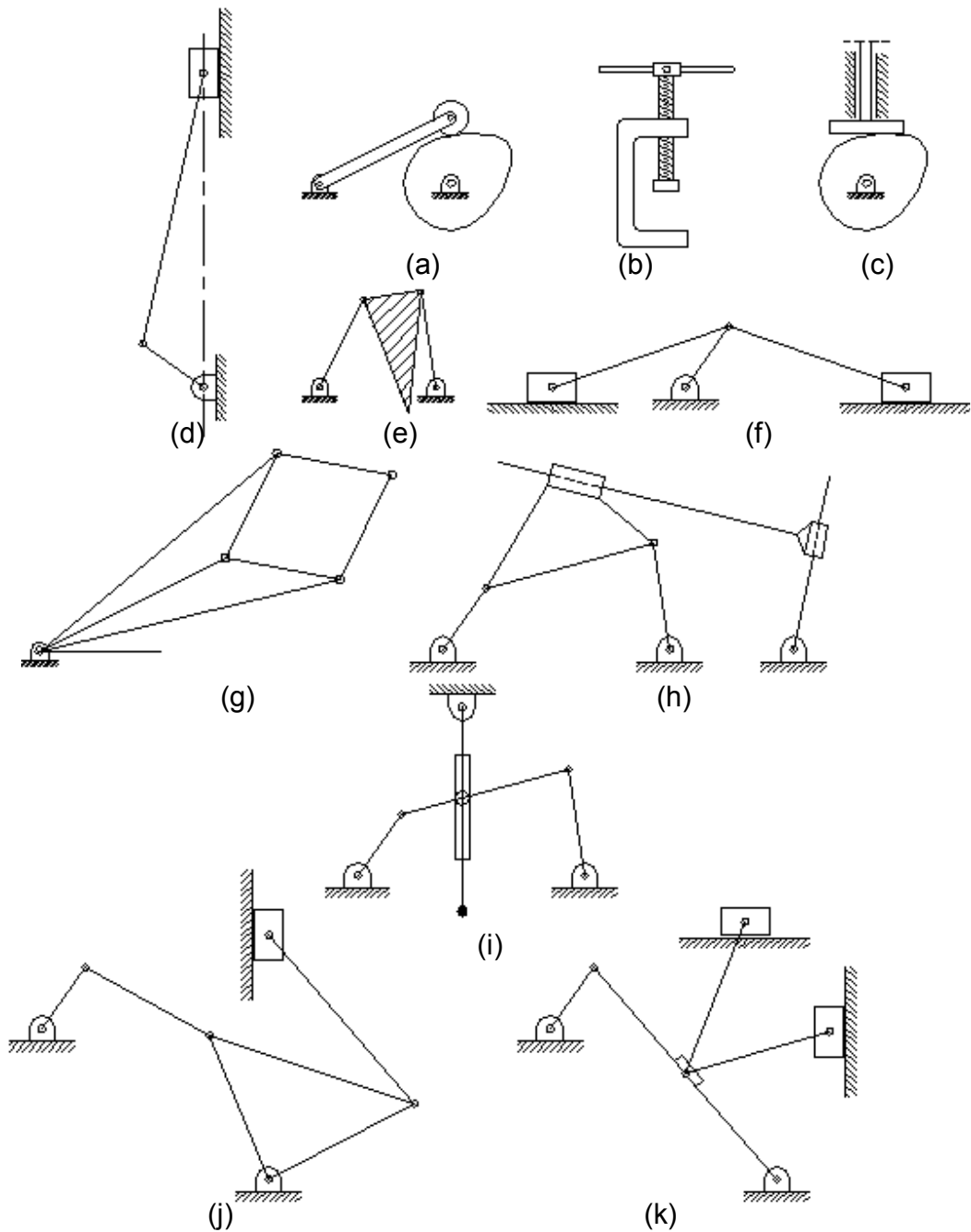

Figure P1.1

Solution

$$\text{DOF} = 3(n - 1) - 2l - h$$

Where,

DOF is the number of degrees of freedom in the mechanism.

n is the number of links including the fixed link.

l is number of lower pairs.

h is the number of higher pairs.

(a) $n = 4$
 $l = 4$
 $h = 0$
 $\text{DOF} = 1$

(b) $n = 4$
 $l = 3$
 $h = 1$
 $\text{DOF} = 1$

(c) $n = 4$
 $l = 4$
 $h = 0$
 $\text{DOF} = 1$

(d) $n = 4$
 $l = 4$
 $h = 0$
 $\text{DOF} = 1$

(e) $n = 4$
 $l = 4$
 $h = 0$
 $\text{DOF} = 1$

(f) $n = 4$
 $l = 4$
 $h = 0$
 $\text{DOF} = 1$

(g) $n = 4$
 $l = 4$
 $h = 0$

$$\text{DOF} = 1$$

$$\begin{aligned} \text{(h)} \quad n &= 4 \\ l &= 4 \\ h &= 0 \\ \text{DOF} &= 1 \end{aligned}$$

$$\begin{aligned} \text{(i)} \quad n &= 4 \\ l &= 4 \\ h &= 0 \\ \text{DOF} &= 1 \end{aligned}$$

$$\begin{aligned} \text{(j)} \quad n &= 4 \\ l &= 4 \\ h &= 0 \\ \text{DOF} &= 1 \end{aligned}$$

$$\begin{aligned} \text{(k)} \quad n &= 4 \\ l &= 4 \\ h &= 0 \\ \text{DOF} &= 1 \end{aligned}$$

1.2 The lengths of the consequent links of a four bar chain are 40, 120, 100, and 140 mm. Different motions are obtained by fixing one of the links at a time. Plot the relation between the output motion and input motion in all possible cases.

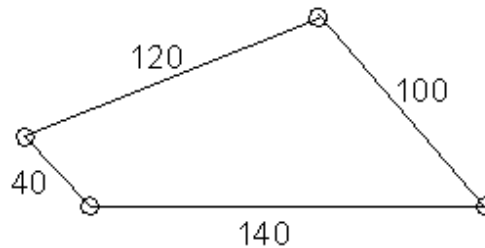

Solution

The relations should be traced manually as explained in Sec 1.3.1.1. However, the results are indicated below.

Case 1: link of length 140 mm is fixed

6

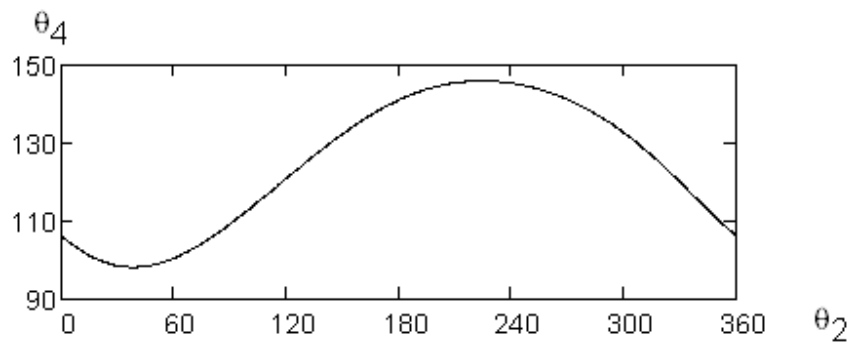
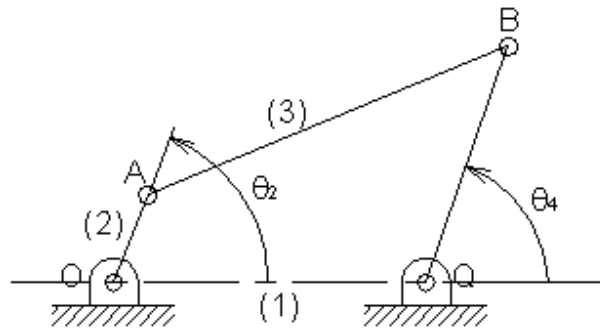

Case 2: link of length 40 mm is fixed

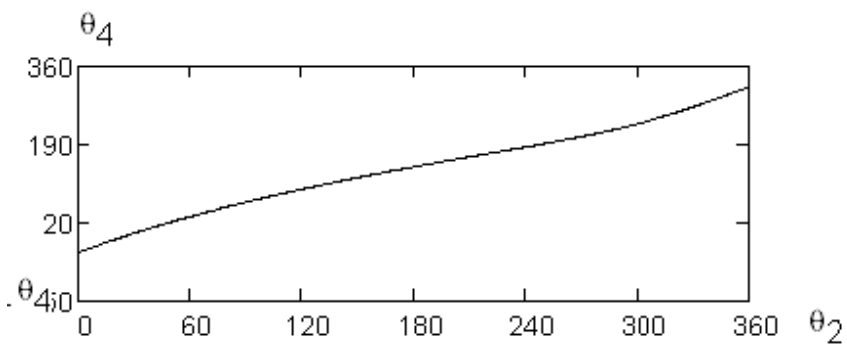
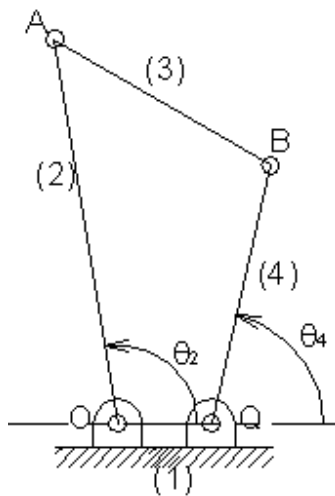

Case 3: link of length 120 mm is fixed.

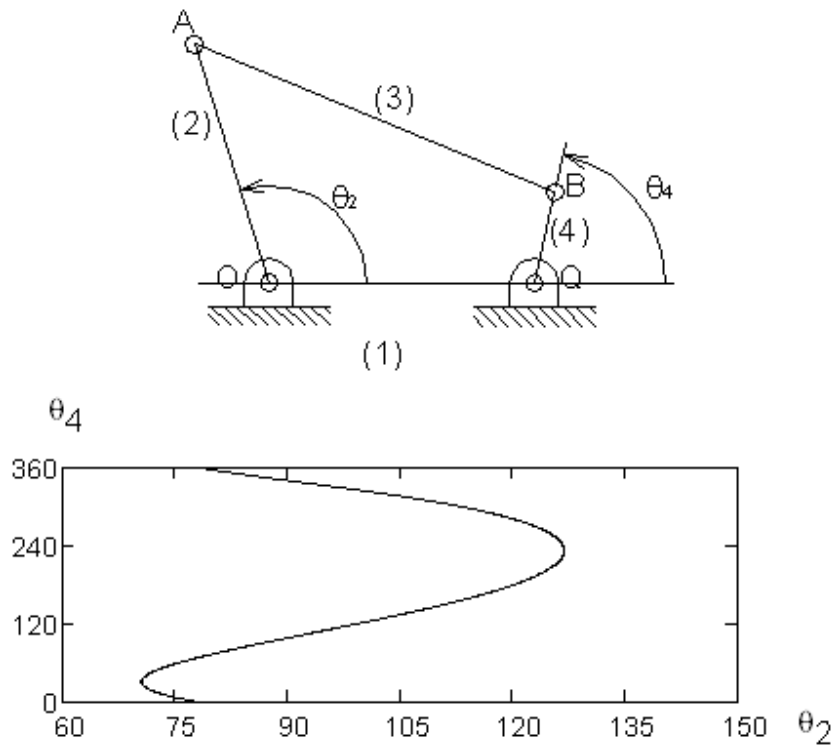

Case 4: link of length 100 mm is fixed

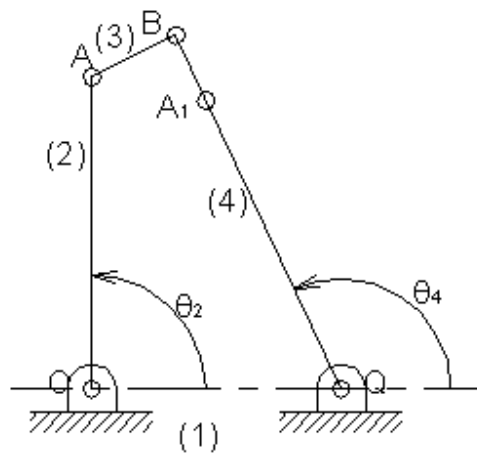

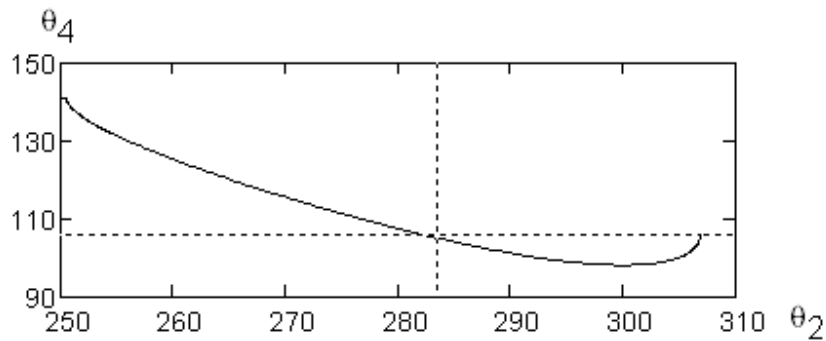

1.3 If the largest link is fixed in the previous chain, trace the path of a point on the middle of the coupler link. Also trace the path of a point on the middle of the rocker on a plane rotating with the crank.

Solution

The trace is shown in the figure.

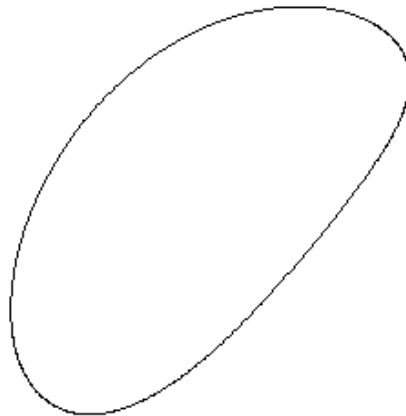

The trace of the path of a point on the middle of the rocker on a plane rotating with the crank is easily done by fixing the crank as in case (2). The trace is a circle with radius 60.

1.4 The lengths of the crank and the connecting rod in a single slider crank chain are 60 and 150 mm respectively. For all possible inversions, plot the output motion against the input motion.

9

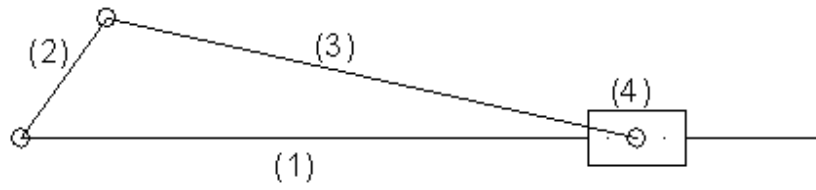

Solution

Case 1: link (1) is fixed

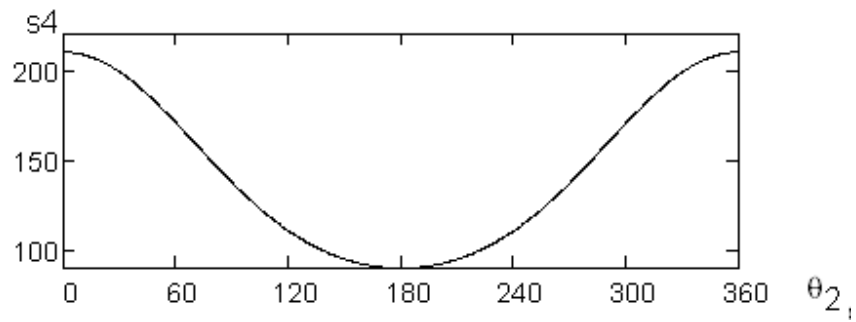
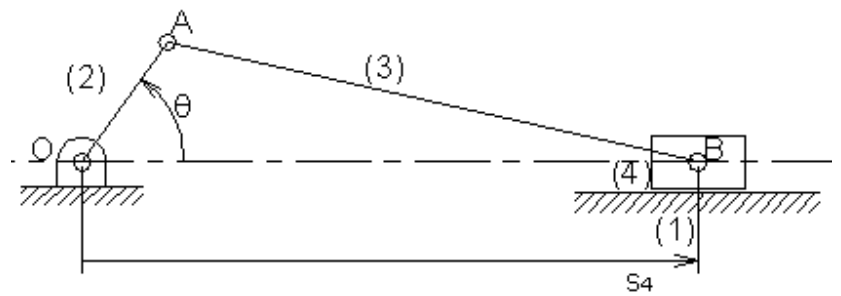

Case 2: link (2) is fixed

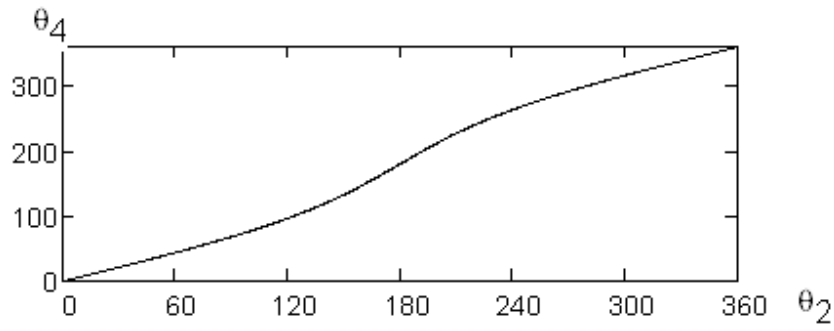
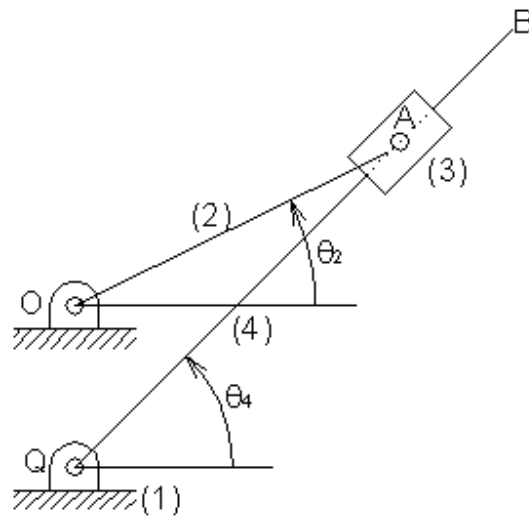

Case 3: link (3) is fixed

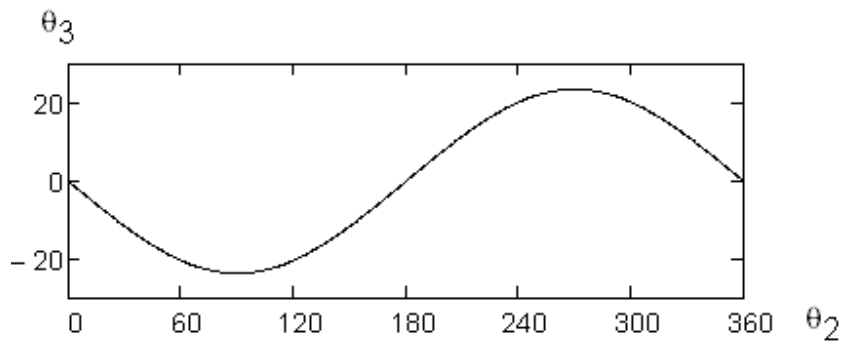
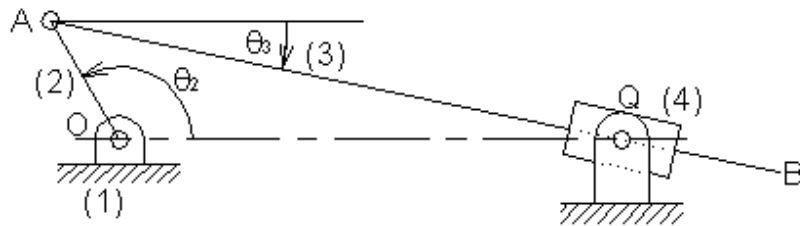

Case 4: link (3) is fixed

We get the shaper mechanism.

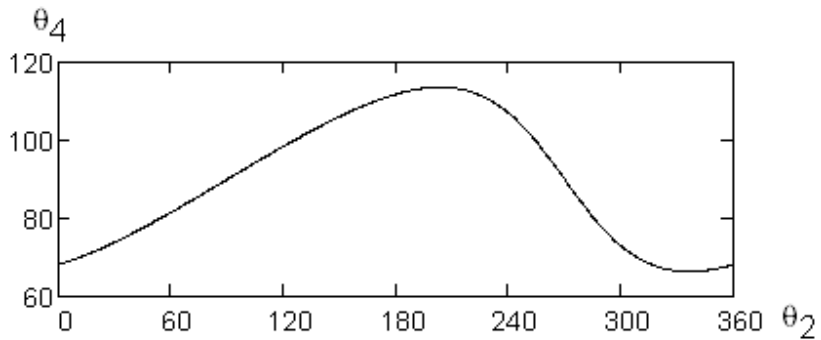
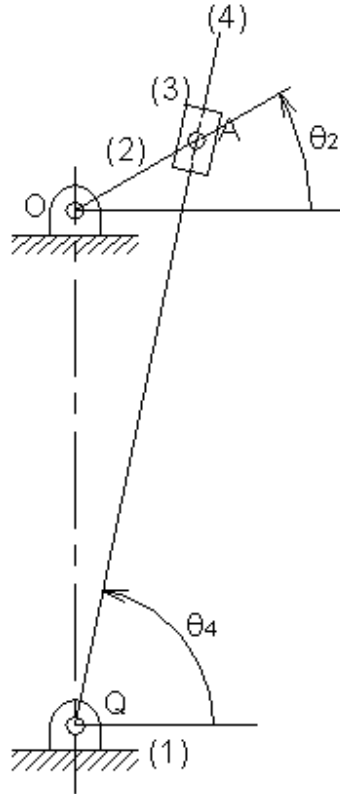

1.5 The distance between the centers of the two blocks of an ellipse trammel is 75 mm. Plot the path of a point on the coupling link 75 mm away from the nearest block. Also, trace the path of a point half way the distance between the centers of the two blocks.

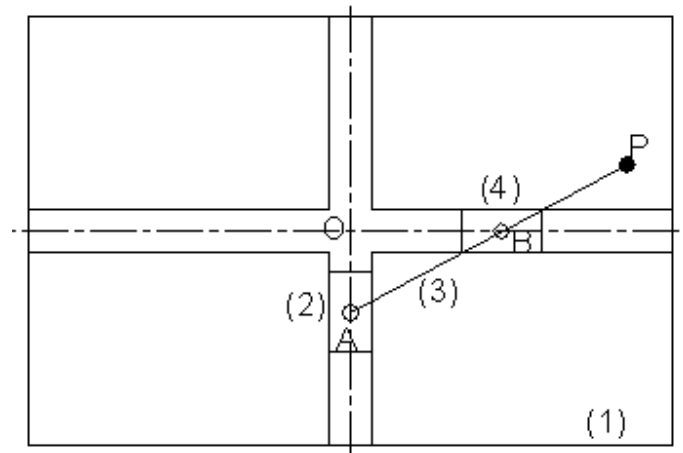
Solution

$AB = 75$ and $BP = 75$. The trace is shown in the figure.

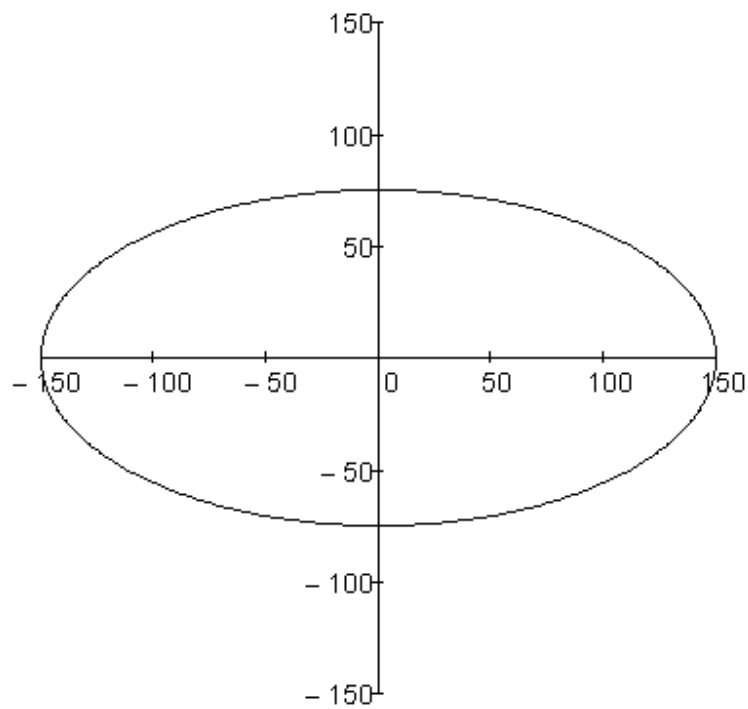

1.6 For the shaper mechanism shown in Figure P1.6, plot the motion of the ram R with the crank rotational angle θ . Also, plot the path of point P on the middle of link BR.

$OA = 30$ mm, $QB = 200$ mm, $BR = 150$ mm, $BP = 75$ mm.

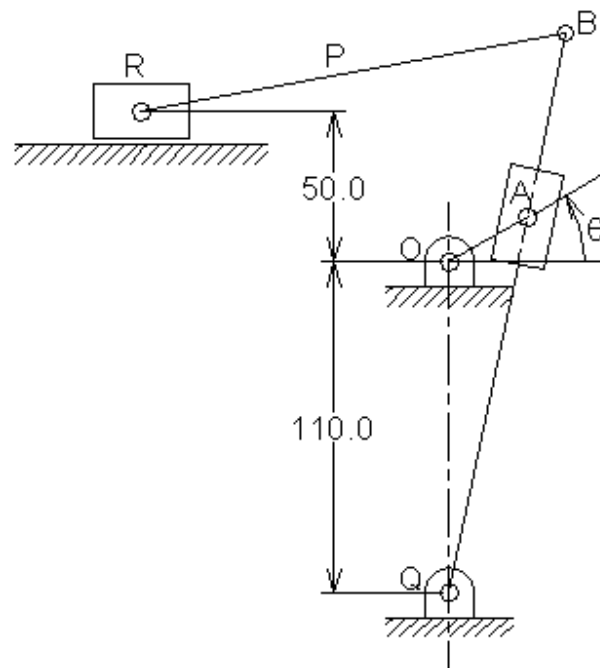
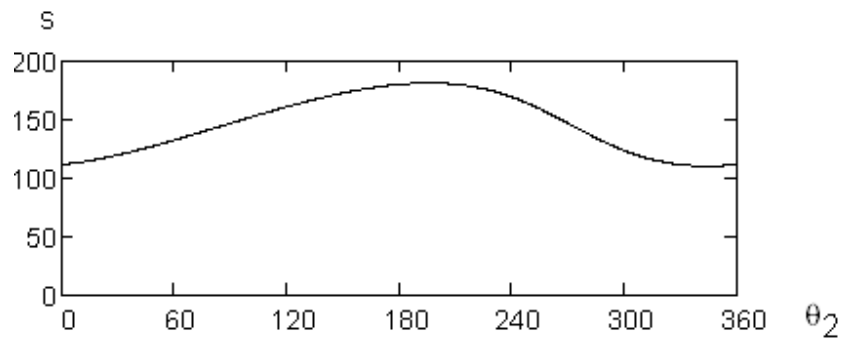
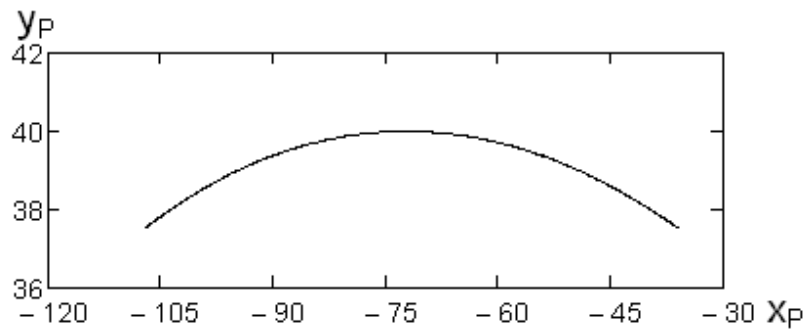

Figure P1.6

Solution



“s” is the horizontal distance from point O. For the path of point P,



1.7 Draw the outline skeleton of the mechanism used in the head of a sewing machine to the needle bar Figure P1.7. Plot the path of point N on the needle bar starting from the lowest position and using 16 divisions. Trace also the path of point P on the middle of link CN.

OA = 40 mm, AB = 120 mm, QB = 80 mm, QC = 50 mm, CN = 150 mm, CP = 75 mm

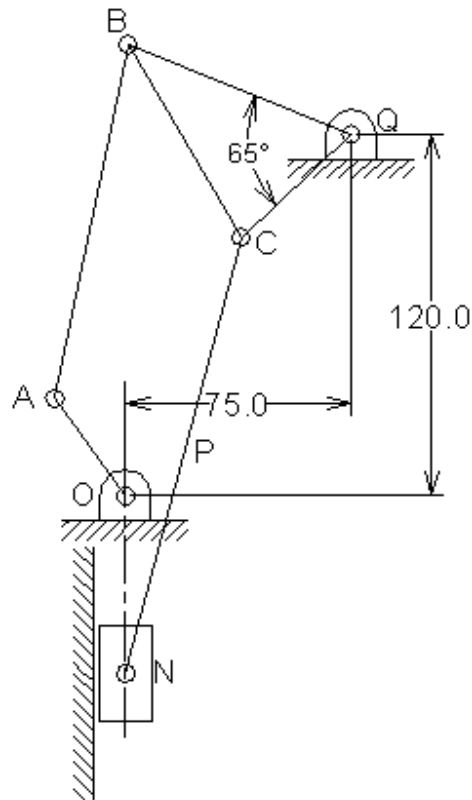
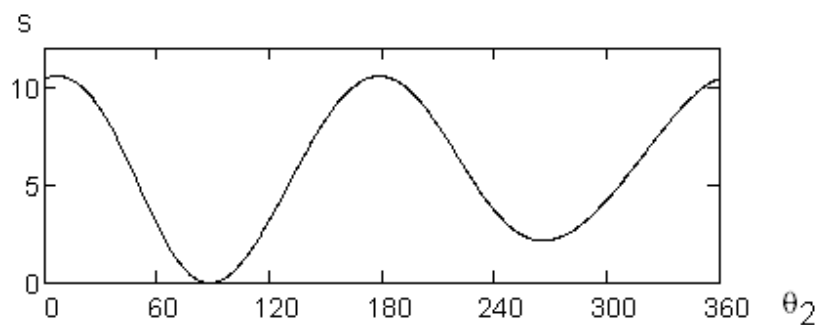

Figure P1.7

Solution

The motion of point N is shown in the figure.



The path of point P is shown in the figure.

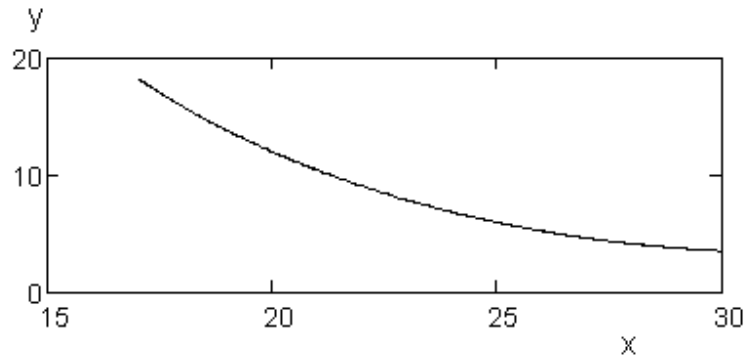

1.8 Design a four-bar mechanism such that $r_1 = 100$ mm, $r_3 = 80$ mm, the rocker angle is 60° , and the time ratio is 1.

Solution

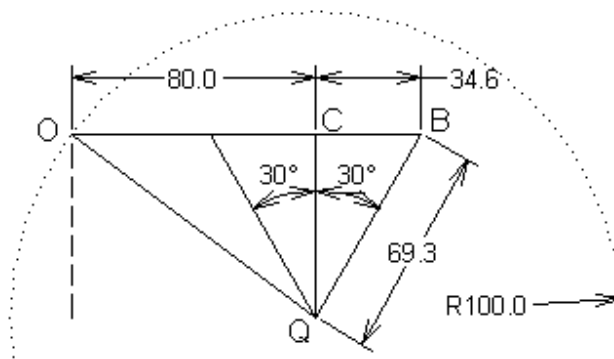

For a time ratio 1, $\alpha = 180^\circ$.

- Draw a circle with radius $QO = 100$ mm.
- From point Q, draw a vertical line with a horizontal distance 80 mm from point Q to intersect the circle at point O.
- From point Q, draw two lines which incline 30° with the vertical.

$$CB = r_2 = 34.6 \text{ mm}$$

$$QB = r_3 = 69.3 \text{ mm}$$

1.9 Design a four-bar mechanism such that $r_2 = 30$ mm, $r_3 = 70$ mm, the rocker angle is 90° , and the time ratio is 1.2.

Solution

$$\lambda = \frac{2\pi - \alpha}{\alpha} = 1.2$$

$$\alpha = 163.6^\circ$$

The angle between the rocker at the two extreme positions is $180 - 163.6 = 16.4^\circ$.

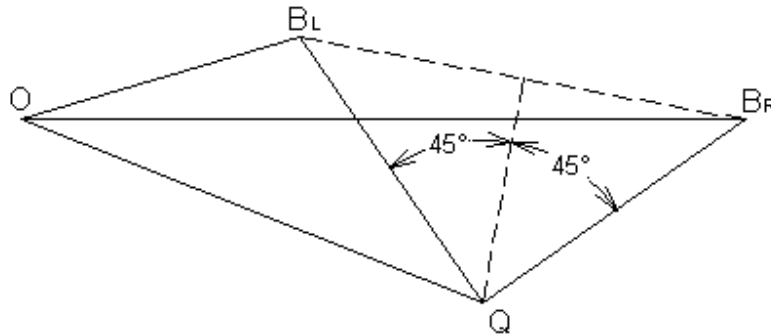

- Draw line OB_R with length of 100 mm ($r_2 + r_3$).
- Draw line OB_L with length of 40 mm ($r_3 - r_2$), with an angle 16.4° with OB_R .
- Bisect line $B_R B_L$, draw two lines from points B_R and B_L , each makes an angle 45° with the bisector.

$$r_3 = 44.3 \text{ mm}$$

$$r_2 = 68.33 \text{ mm}$$

1.10 Design a four-bar mechanism such that $r_1 = 100 \text{ mm}$, $r_2 = 30 \text{ mm}$, $r_3 = 70 \text{ mm}$, and the time ratio is 1.2.

Solution

The same steps of the previous problem are followed, except, we draw a circle of radius 100 mm from point O to intersect the bisector at point Q.

$$R_4 = 97.4 \text{ mm}$$

$$\phi = 37^\circ$$

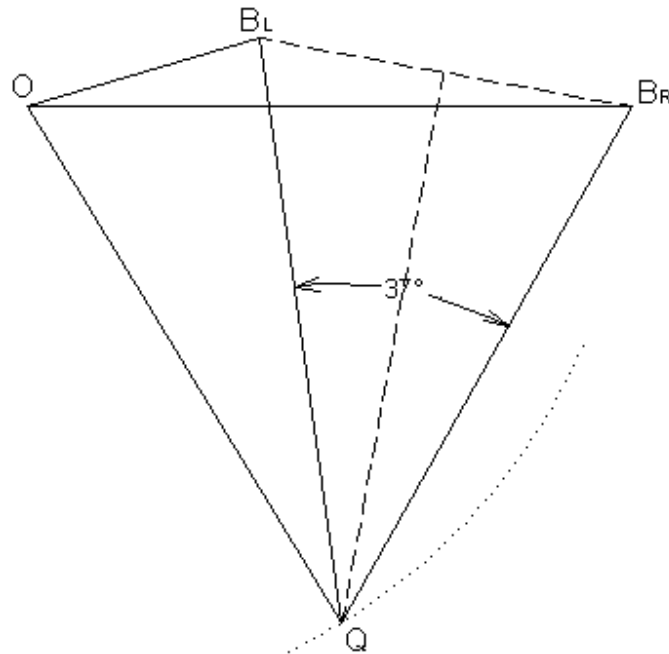

1.11 For the shaper mechanism of Problem 1.6, obtain the time ratio. When the crank makes 30° with the horizontal datum, point C is a point on the oscillatory link under point A. Trace the path of C on a plane rotating with the crank.

Solution

When link (4) is at the extreme position, it makes an angle $= \cos^{-1} (OA/OQ) = 74.173^\circ$. Thus, the time ratio is,

$$\lambda = (360.2 \cdot 74.173) / 74.173 \cdot 2 = 1.427$$

At this position, $OC = 127.7$ mm. To trace the path of C on a plane rotating with the crank, we fix the crank and rotate OQ about point O at the different positions. At each position we locate a point at a distance 127.7 mm from point Q. The trace is shown in the figure.

