

CHAPTER 1

Problem 1.1

Starting from the basic definition of stiffness, determine the effective stiffness of the combined spring and write the equation of motion for the spring–mass systems shown in Fig. P1.1.

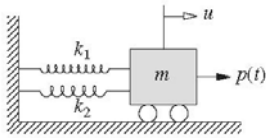
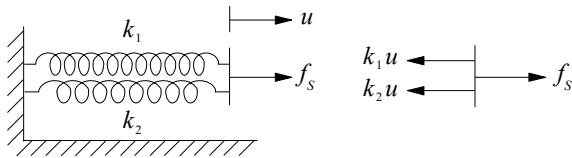

Figure P1.1

Solution:

If k_e is the effective stiffness,

$$f_S = k_e u$$



Equilibrium of forces: $f_S = (k_1 + k_2) u$

Effective stiffness: $k_e = f_S/u = k_1 + k_2$

Equation of motion: $m\ddot{u} + k_e u = p(t)$

Problem 1.2

Starting from the basic definition of stiffness, determine the effective stiffness of the combined spring and write the equation of motion for the spring–mass systems shown in Fig. P1.2.

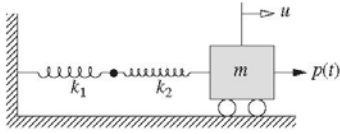
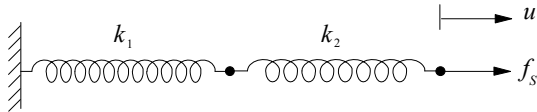

Figure P1.2

Solution:

If k_e is the effective stiffness,

$$f_S = k_e u \quad (a)$$



If the elongations of the two springs are u_1 and u_2 ,

$$u = u_1 + u_2 \quad (b)$$

Because the force in each spring is f_S ,

$$f_S = k_1 u_1 \quad f_S = k_2 u_2 \quad (c)$$

Solving for u_1 and u_2 and substituting in Eq. (b) gives

$$\begin{aligned} \frac{f_S}{k_e} &= \frac{f_S}{k_1} + \frac{f_S}{k_2} \Rightarrow \frac{1}{k_e} = \frac{1}{k_1} + \frac{1}{k_2} \Rightarrow \\ k_e &= \frac{k_1 k_2}{k_1 + k_2} \end{aligned}$$

Equation of motion: $m\ddot{u} + k_e u = p(t)$.

Problem 1.3

Starting from the basic definition of stiffness, determine the effective stiffness of the combined spring and write the equation of motion for the spring–mass systems shown in Fig. P1.3.

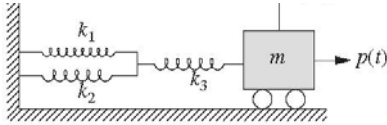

Figure P1.3

Solution:

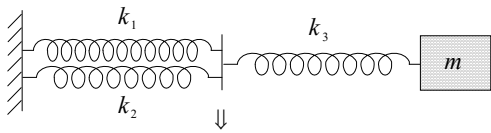

Figure P1.3a

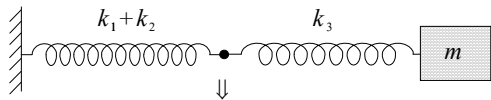

Figure P1.3b

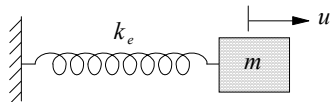

Figure P1.3c

This problem can be solved either by starting from the definition of stiffness or by using the results of Problems P1.1 and P1.2. We adopt the latter approach to illustrate the procedure of reducing a system with several springs to a single equivalent spring.

First, using Problem 1.1, the parallel arrangement of k_1 and k_2 is replaced by a single spring, as shown in Fig. 1.3b. Second, using the result of Problem 1.2, the series arrangement of springs in Fig. 1.3b is replaced by a single spring, as shown in Fig. 1.3c:

$$\frac{1}{k_e} = \frac{1}{k_1 + k_2} + \frac{1}{k_3}$$

Therefore the effective stiffness is

$$k_e = \frac{(k_1 + k_2)k_3}{k_1 + k_2 + k_3}$$

The equation of motion is $m\ddot{u} + k_e u = p(t)$.

Problem 1.4

Derive the equation governing the free motion of a simple pendulum that consists of a rigid massless rod pivoted at point O with a mass m attached at the tip (Fig. P1.4). Linearize the equation, for small oscillations, and determine the natural frequency of oscillation.

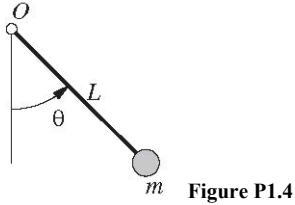

4. Determine natural frequency.

$$\omega_n = \sqrt{\frac{g}{L}}$$

Solution:

1. Draw a free body diagram of the mass.

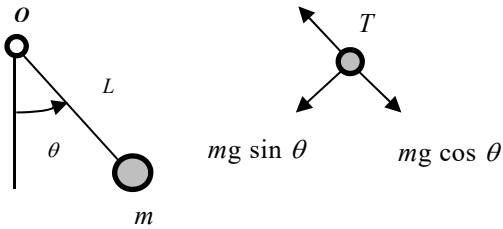

2. Write equation of motion in tangential direction.

Method 1: By Newton's law.

$$\begin{aligned} -mg \sin \theta &= ma \\ -mg \sin \theta &= mL\ddot{\theta} \\ mL\ddot{\theta} + mg \sin \theta &= 0 \end{aligned} \tag{a}$$

This nonlinear differential equation governs the motion for any rotation θ .

Method 2: Equilibrium of moments about O yields

$$mL^2\ddot{\theta} = -mgL \sin \theta$$

or

$$mL\ddot{\theta} + mg \sin \theta = 0$$

3. Linearize for small θ .

For small θ , $\sin \theta \approx \theta$, and Eq. (a) becomes

$$\begin{aligned} mL\ddot{\theta} + mg\theta &= 0 \\ \ddot{\theta} + \left(\frac{g}{L}\right)\theta &= 0 \end{aligned} \tag{b}$$

Problem 1.5

Consider the free motion in the xy plane of a compound pendulum that consists of a rigid rod suspended from a point (Fig. P1.5). The length of the rod is L , and its mass m is uniformly distributed. The width of the uniform rod is b and the thickness is t . The angular displacement of the centerline of the pendulum measured from the y -axis is denoted by $\theta(t)$.

- Derive the equation governing $\theta(t)$.
- Linearize the equation for small θ .
- Determine the natural frequency of small oscillations.

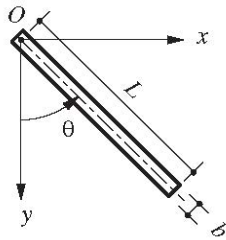

Figure P1.5

Solution:

- Find the moment of inertia about O .

From Appendix 8,

$$I_0 = \frac{1}{12} mL^2 + m \left(\frac{L}{2} \right)^2 = \frac{1}{3} mL^2$$

- Draw a free body diagram of the body in an arbitrary displaced position.

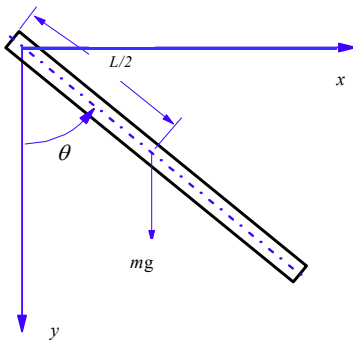

- Write the equation of motion using Newton's second law of motion.

$$\sum M_0 = I_0 \ddot{\theta}$$

$$-mg \frac{L}{2} \sin \theta = \frac{1}{3} mL^2 \ddot{\theta}$$

$$\frac{mL^2}{3} \ddot{\theta} + \frac{mgL}{2} \sin \theta = 0 \quad (a)$$

- Specialize for small θ .

For small θ , $\sin \theta \cong \theta$ and Eq. (a) becomes

$$\frac{mL^2}{3} \ddot{\theta} + \frac{mgL}{2} \theta = 0$$

$$\ddot{\theta} + \frac{3g}{2L} \theta = 0 \quad (b)$$

- Determine natural frequency.

$$\omega_n = \sqrt{\frac{3g}{2L}}$$

Problem 1.6

Repeat Problem 1.5 for the system shown in Fig. P1.6, which differs in only one sense: its width varies from zero at O to b at the free end.

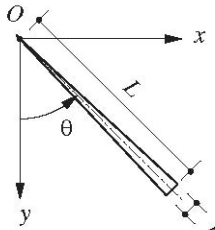

Figure P1.6

Solution:

1. Find the moment of inertia about O .

$$\begin{aligned}
 I_0 &= \rho \int_0^L r^2 dA \\
 &= \rho \int_0^L r^2 (r \alpha dr) \\
 &= \frac{\rho}{4} L^4 \alpha \\
 &= \frac{1}{2} mL^2
 \end{aligned}$$

2. Draw a free body diagram of the body in an arbitrary displaced position.

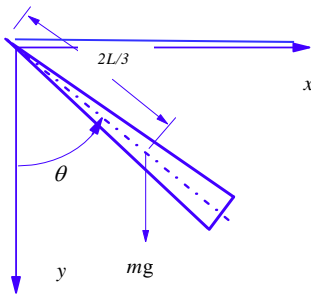

3. Write the equation of motion using Newton's second law of motion.

$$\begin{aligned}
 \sum M_0 &= I_0 \ddot{\theta} \\
 -mg \frac{2L}{3} \sin \theta &= \frac{1}{2} mL^2 \ddot{\theta} \\
 \frac{mL^2}{2} \ddot{\theta} + \frac{2mgL}{3} \sin \theta &= 0 \tag{a}
 \end{aligned}$$

4. Specialize for small θ .

For small θ , $\sin \theta \cong \theta$, and Eq. (a) becomes

$$\frac{mL^2}{2} \ddot{\theta} + \frac{2mgL}{3} \theta = 0$$

or

$$\ddot{\theta} + \frac{4g}{3L} \theta = 0 \tag{b}$$

5. Determine natural frequency.

$$\omega_n = \sqrt{\frac{4g}{3L}}$$

In each case the system is equivalent to the spring-mass system shown for which the equation of motion is

$$\left(\frac{w}{g} \right) \ddot{u} + ku = 0$$

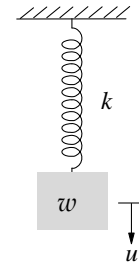

The spring stiffness is determined from the deflection u under a vertical force f_s applied at the location of the lumped weight:

Simply-supported beam: $u = \frac{f_s L^3}{48EI} \Rightarrow k = \frac{48EI}{L^3}$

Cantilever beam: $u = \frac{f_s L^3}{3EI} \Rightarrow k = \frac{3EI}{L^3}$

Clamped beam: $u = \frac{f_s L^3}{192EI} \Rightarrow k = \frac{192EI}{L^3}$

Problem 1.7

Develop the equation governing the longitudinal motion of the system of Fig. P1.7. The rod is made of an elastic material with elastic modulus E ; its cross-sectional area is A and its length is L . Ignore the mass of the rod and measure u from the static equilibrium position.

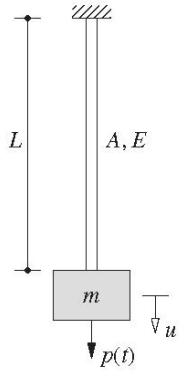
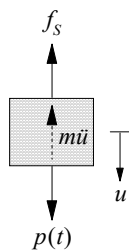

Figure P1.7

Solution:

Draw a free body diagram of the mass:



Write equation of dynamic equilibrium:

$$m\ddot{u} + f_s = p(t) \quad (a)$$

Write the force-displacement relation:

$$f_s = \left(\frac{AE}{L}\right)u \quad (b)$$

Substitute Eq. (b) into Eq. (a) to obtain the equation of motion:

$$m\ddot{u} + \left(\frac{AE}{L}\right)u = p(t)$$

Problem 1.8

A rigid disk of mass m is mounted at the end of a flexible shaft (Fig. P1.8). Neglecting the weight of the shaft and neglecting damping, derive the equation of free torsional vibration of the disk. The shear modulus (of rigidity) of the shaft is G .

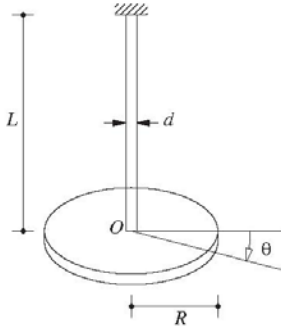
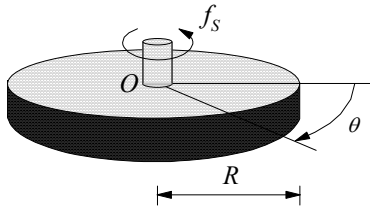

Figure P1.8

Solution:

Show forces on the disk:



Write the equation of motion using Newton's second law of motion:

$$-f_s = I_o \ddot{\theta} \quad \text{where} \quad I_o = \frac{mR^2}{2} \quad (\text{a})$$

Write the torque-twist relation:

$$f_s = \left(\frac{GJ}{L} \right) \theta \quad \text{where} \quad J = \frac{\pi d^4}{32} \quad (\text{b})$$

Substitute Eq. (b) into Eq. (a):

$$I_o \ddot{\theta} + \left(\frac{GJ}{L} \right) \theta = 0$$

or,

$$\left(\frac{mR^2}{2} \right) \ddot{\theta} + \left(\frac{\pi d^4 G}{32L} \right) \theta = 0$$

Problems 1.9 through 1.11

Write the equation governing the free vibration of the systems shown in Figs. P1.9 to P1.11. Assuming the beam to be massless, each system has a single DOF defined as the vertical deflection under the weight w . The flexural rigidity of the beam is EI and the length is L .

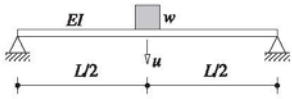

Figure P1.9

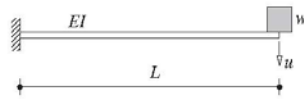

Figure P1.10

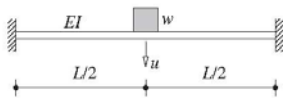
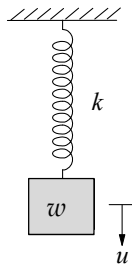

Figure P1.11

Solution:

In each case the system is equivalent to the spring-mass system shown for which the equation of motion is

$$\left(\frac{w}{g}\right)\ddot{u} + ku = 0$$



The spring stiffness is determined from the deflection u under a vertical force f_s applied at the location of the lumped weight:

$$\text{Simply-supported beam: } u = \frac{f_s L^3}{48EI} \Rightarrow k = \frac{48EI}{L^3}$$

$$\text{Cantilever beam: } u = \frac{f_s L^3}{3EI} \Rightarrow k = \frac{3EI}{L^3}$$

$$\text{Clamped beam: } u = \frac{f_s L^3}{192EI} \Rightarrow k = \frac{192EI}{L^3}$$

Problem 1.12

Determine the natural frequency of a weight w suspended from a spring at the midpoint of a simply supported beam (Fig. P1.12). The length of the beam is L , and its flexural rigidity is EI . The spring stiffness is k . Assume the beam to be massless.

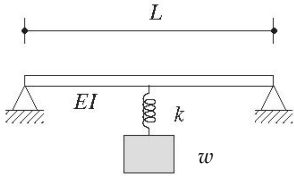

Figure P1.12

Solution:

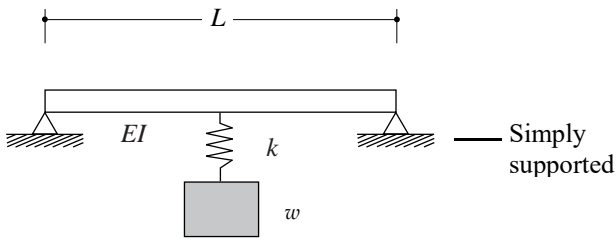

Figure 1.12a

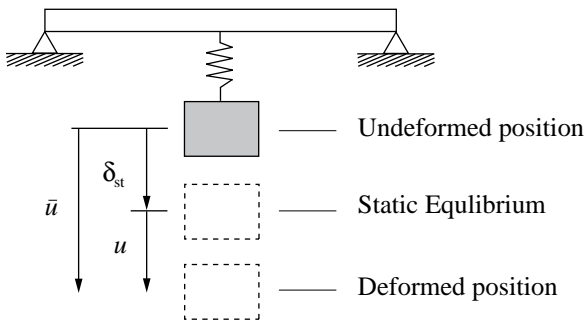

Figure 1.12b

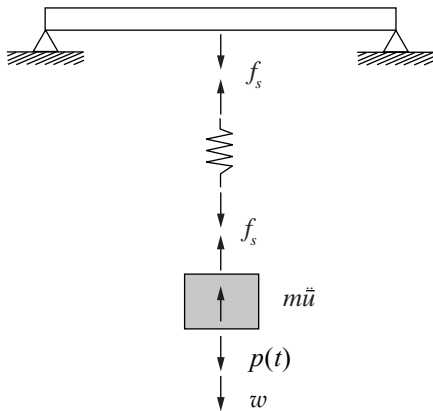

Figure 1.12c

1. Write the equation of motion.

Equilibrium of forces in Fig. 1.12c gives

$$m\ddot{u} + f_s = w + p(t) \tag{a}$$

where

$$f_s = k_e \bar{u} \tag{b}$$

The equation of motion is:

$$m\ddot{u} + k_e \bar{u} = w + p(t) \tag{c}$$

2. Determine the effective stiffness.

$$f_s = k_e \bar{u} \tag{d}$$

where

$$\bar{u} = \delta_{\text{spring}} + \delta_{\text{beam}} \tag{e}$$

$$f_s = k \delta_{\text{spring}} = k_{\text{beam}} \delta_{\text{beam}} \tag{f}$$

Substitute for the δ 's from Eq. (f) and for \bar{u} from Eq. (d):

$$\frac{f_s}{k_e} = \frac{f_s}{k} + \frac{f_s}{k_{\text{beam}}}$$

$$k_e = \frac{kk_{\text{beam}}}{k + k_{\text{beam}}}$$

$$k_e = \frac{k(48EI/L^3)}{k + \frac{48EI}{L^3}}$$

3. Determine the natural frequency.

$$\omega_n = \sqrt{\frac{k_e}{m}}$$

Problem 1.13

Derive the equation of motion for the frame shown in Fig. P1.13. The flexural rigidity of the beam and columns is as noted. The mass lumped at the beam is m ; otherwise, assume the frame to be massless and neglect damping. By comparing the result with Eq. (1.3.2), comment on the effect of base fixity.

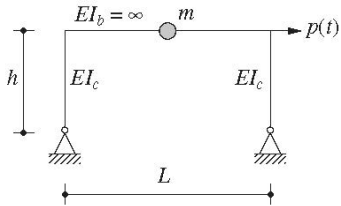
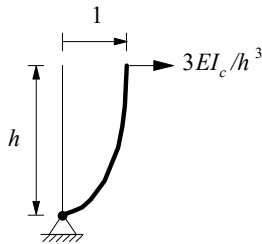

Figure P1.13

Solution:

Compute lateral stiffness:



$$k = 2 \times k_{\text{column}} = 2 \times \frac{3EI_c}{h^3} = \frac{6EI_c}{h^3}$$

Equation of motion:

$$m\ddot{u} + ku = p(t)$$

Base fixity increases k by a factor of 4.

Problem 1.14

Write the equation of motion for the one-story, one-bay frame shown in Fig. P1.14. The flexural rigidity of the beam and columns is as noted. The mass lumped at the beam is m ; otherwise, assume the frame to be massless and neglect damping. By comparing this equation of motion with the one for Example 1.1, comment on the effect of base fixity.

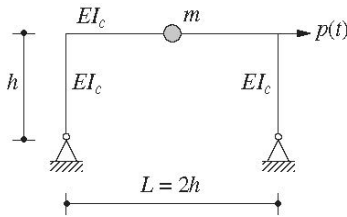

Figure P1.14

Solution:

1. Define degrees-of-freedom (DOF).



2. Reduced stiffness coefficients.

Since there are no external moments applied at the pinned supports, the following reduced stiffness coefficients are used for the columns.

Joint rotation:

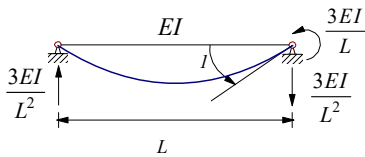

Joint translation:

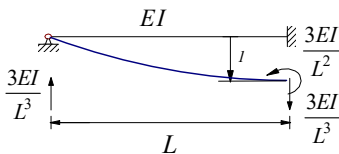

3. Form structural stiffness matrix.

$$u_1 = 1, u_2 = u_3 = 0$$

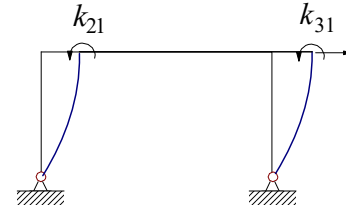

$$u_2 = 1, u_1 = u_3 = 0$$

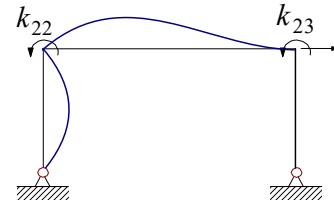

$$k_{22} = \frac{3EI_c}{h} + \frac{4EI_c}{(2h)} = \frac{5EI_c}{h}$$

$$k_{32} = \frac{2EI_c}{(2h)} = \frac{EI_c}{h}$$

$$k_{12} = \frac{3EI_c}{h^2}$$

$$u_3 = 1, u_1 = u_2 = 0$$

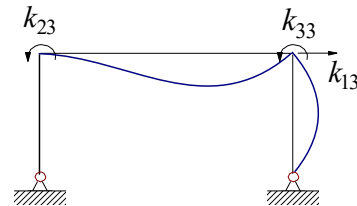

$$k_{33} = \frac{3EI_c}{h} + \frac{4EI_c}{(2h)} = \frac{5EI_c}{h}$$

$$k_{23} = \frac{2EI_c}{(2h)} = \frac{EI_c}{h}$$

$$k_{13} = \frac{3EI_c}{h^2}$$

Hence

$$\mathbf{k} = \frac{EI_c}{h^3} \begin{bmatrix} 6 & 3h & 3h \\ 3h & 5h^2 & h^2 \\ 3h & h^2 & 5h^2 \end{bmatrix}$$

4. Determine lateral stiffness.

The lateral stiffness k of the frame can be obtained by static condensation since there is no force acting on DOF 2 and 3:

$$\frac{EI_c}{h^3} \begin{bmatrix} 6 & 3h & 3h \\ 3h & 5h^2 & h^2 \\ 3h & h^2 & 5h^2 \end{bmatrix} \begin{Bmatrix} u_1 \\ u_2 \\ u_3 \end{Bmatrix} = \begin{Bmatrix} f_S \\ 0 \\ 0 \end{Bmatrix}$$

First partition \mathbf{k} as

$$\mathbf{k} = \frac{EI_c}{h^3} \begin{bmatrix} 6 & 3h & 3h \\ 3h & 5h^2 & h^2 \\ 3h & h^2 & 5h^2 \end{bmatrix} = \begin{bmatrix} \mathbf{k}_{tt} & \mathbf{k}_{t0} \\ \mathbf{k}_{t0} & \mathbf{k}_{00} \end{bmatrix}$$

where

$$\begin{aligned} \mathbf{k}_{tt} &= \frac{EI_c}{h^3} [6] \\ \mathbf{k}_{t0} &= \frac{EI_c}{h^3} [3h \quad 3h] \\ \mathbf{k}_{00} &= \frac{EI_c}{h^3} \begin{bmatrix} 5h^2 & h^2 \\ h^2 & 5h^2 \end{bmatrix} \end{aligned}$$

Then compute the lateral stiffness k from

$$k = \mathbf{k}_{tt} - \mathbf{k}_{t0} \mathbf{k}_{00}^{-1} \mathbf{k}_{t0}^T$$

Since

$$\mathbf{k}_{00}^{-1} = \frac{h}{24EI_c} \begin{bmatrix} 5 & -1 \\ -1 & 5 \end{bmatrix}$$

we get

$$\begin{aligned} k &= \frac{6EI_c}{h^3} - \frac{EI_c}{h^3} [3h \quad 3h] \cdot \frac{h}{24EI_c} \begin{bmatrix} 5 & -1 \\ -1 & 5 \end{bmatrix} \cdot \frac{EI_c}{h^3} \begin{bmatrix} 3h \\ 3h \end{bmatrix} \\ k &= \frac{EI_c}{h^3} [6 - 3] \\ k &= \frac{3EI_c}{h^3} \end{aligned}$$

5. Equation of motion.

$$m\ddot{u} + \frac{3EI_c}{h^3}u = p(t)$$

Problem 1.15

Write the equation of motion of the one-story, one-bay frame shown in Fig. P1.15. The flexural rigidity of the beam and columns is as noted. The mass lumped at the beam is m ; otherwise, assume the frame to be massless and neglect damping. Check your result from Problem 1.15 against Eq. (1.3.5). Comment on the effect of base fixity by comparing the two equations of motion.

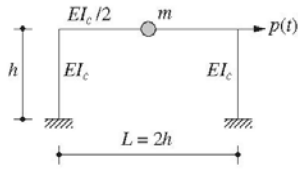
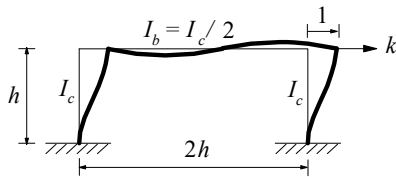

Figure P1.15

Solution:



Define degrees-of-freedom (DOF):



Form structural stiffness matrix:

$$u_1 = 1, \quad u_2 = u_3 = 0$$

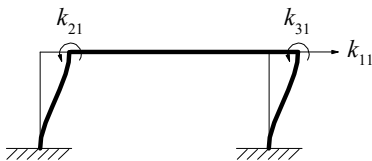

$$k_{11} = 2 \frac{12EI_c}{h^3} = \frac{24EI_c}{h^3}$$

$$k_{21} = k_{31} = \frac{6EI_c}{h^2}$$

$$u_2 = 1, \quad u_1 = u_3 = 0$$

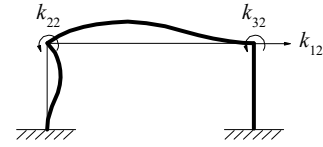

$$k_{22} = \frac{4EI_c}{h} + \frac{4EI_b}{(2h)} = \frac{4EI_c}{h} + \frac{EI_c}{h} = \frac{5EI_c}{h}$$

$$k_{32} = \frac{2EI_b}{(2h)} = \frac{EI_c}{2h}$$

$$k_{12} = \frac{6EI_c}{h^2}$$

$$u_3 = 1, \quad u_1 = u_2 = 0$$

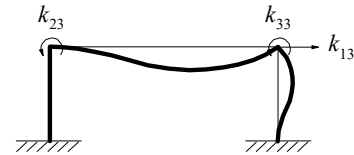

$$k_{33} = \frac{4EI_c}{h} + \frac{4EI_b}{(2h)} = \frac{4EI_c}{h} + \frac{EI_c}{h} = \frac{5EI_c}{h}$$

$$k_{23} = \frac{2EI_b}{(2h)} = \frac{EI_c}{2h}$$

$$k_{13} = \frac{6EI_c}{h^2}$$

Hence

$$\mathbf{k} = \frac{EI_c}{h^3} \begin{bmatrix} 24 & 6h & 6h \\ 6h & 5h^2 & \frac{1}{2}h^2 \\ 6h & \frac{1}{2}h^2 & 5h^2 \end{bmatrix}$$

The lateral stiffness k of the frame can be obtained by static condensation since there is no force acting on DOF 2 and 3:

$$\frac{EI_c}{h^3} \begin{bmatrix} 24 & 6h & 6h \\ 6h & 5h^2 & \frac{1}{2}h^2 \\ 6h & \frac{1}{2}h^2 & 5h^2 \end{bmatrix} \begin{Bmatrix} u_1 \\ u_2 \\ u_3 \end{Bmatrix} = \begin{Bmatrix} f_S \\ 0 \\ 0 \end{Bmatrix}$$

First partition \mathbf{k} as

$$\mathbf{k} = \frac{EI_c}{h^3} \begin{bmatrix} 24 & 6h & 6h \\ 6h & 5h^2 & \frac{1}{2}h^2 \\ 6h & \frac{1}{2}h^2 & 5h^2 \end{bmatrix} = \begin{bmatrix} \mathbf{k}_{tt} & \mathbf{k}_{t0} \\ \mathbf{k}_{t0}^T & \mathbf{k}_{00} \end{bmatrix}$$

where

$$\mathbf{k}_{tt} = \frac{EI_c}{h^3} [24]$$

$$\mathbf{k}_{t0} = \frac{EI_c}{h^3} [6h \quad 6h]$$

$$\mathbf{k}_{00} = \frac{EI_c}{h^3} \begin{bmatrix} 5h^2 & \frac{1}{2}h^2 \\ \frac{1}{2}h^2 & 5h^2 \end{bmatrix}$$

Then compute the lateral stiffness k from

$$k = \mathbf{k}_{tt} - \mathbf{k}_{t0} \mathbf{k}_{00}^{-1} \mathbf{k}_{t0}^T$$

Since

$$\mathbf{k}_{00}^{-1} = \frac{4h}{99EI_c} \begin{bmatrix} 5 & -\frac{1}{2} \\ -\frac{1}{2} & 5 \end{bmatrix}$$

we get

$$\begin{aligned} k &= \frac{24EI_c}{h^3} - \frac{EI_c}{h^3} [6h \quad 6h] \cdot \frac{4h}{99EI_c} \begin{bmatrix} 5 & -\frac{1}{2} \\ -\frac{1}{2} & 5 \end{bmatrix} \cdot \frac{EI_c}{h^3} \begin{bmatrix} 6h \\ 6h \end{bmatrix} \\ &= \frac{EI_c}{h^3} \left(24 - \frac{144}{11} \right) \\ &= \frac{120}{11} \frac{EI_c}{h^3} \end{aligned}$$

This result can be checked against Eq. 1.3.5:

$$k = \frac{24EI_c}{h^3} \left(\frac{12\rho+1}{12\rho+4} \right)$$

Substituting $\rho = I_b/4I_c = 1/8$ gives

$$k = \frac{24EI_c}{h^3} \left(\frac{12\frac{1}{8}+1}{12\frac{1}{8}+4} \right) = \frac{24EI_c}{h^3} \left(\frac{5}{11} \right) = \frac{120}{11} \frac{EI_c}{h^3}$$

Equation of motion:

$$m \ddot{u} + \left(\frac{120}{11} \frac{EI_c}{h^3} \right) u = p(t)$$

Problem 1.16

Write the equation of motion of the one-story, one-bay frame shown in Fig. P1.16. The flexural rigidity of the beam and columns is as noted. The mass lumped at the beam is m ; otherwise, assume the frame to be massless and neglect damping.

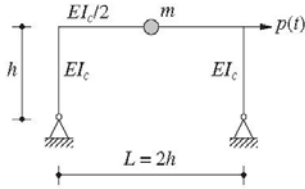
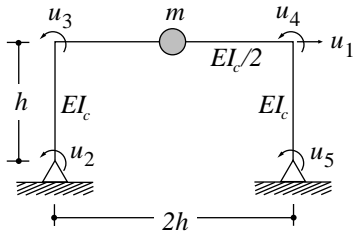

Figure P1.16

Solution:

1. Define degrees-of-freedom (DOF).



2. Form the structural stiffness matrix.

$$u_1 = 1, \quad u_2 = u_3 = u_4 = u_5 = 0$$

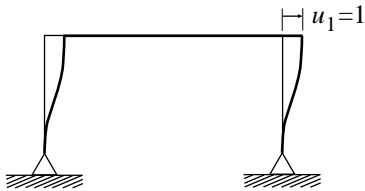

$$k_{11} = 2 \frac{12EI_c}{h^3} = \frac{24EI_c}{h^3}$$

$$k_{21} = k_{31} = k_{41} = k_{51} = \frac{6EI_c}{h^2}$$

$$u_2 = 1, \quad u_1 = u_3 = u_4 = u_5 = 0$$



$$k_{22} = \frac{4EI_c}{h}$$

$$k_{12} = \frac{6EI_c}{h^2}$$

$$k_{32} = \frac{2EI_c}{h}$$

$$k_{42} = k_{52} = 0$$

$$u_3 = 1, \quad u_1 = u_2 = u_4 = u_5 = 0$$

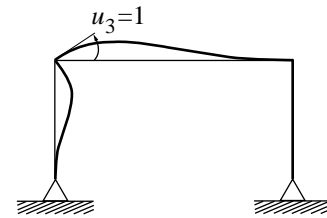

$$k_{33} = \frac{4EI_c}{h} + \frac{4EI_c}{2(2h)} = \frac{5EI_c}{h}$$

$$k_{13} = \frac{6EI_c}{h^2}, \quad k_{23} = \frac{2EI_c}{h}$$

$$k_{43} = \frac{2EI_c}{2(2h)} = \frac{EI_c}{2h}, \quad k_{53} = 0$$

$$u_4 = 1, \quad u_1 = u_2 = u_3 = u_5 = 0$$

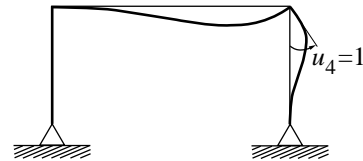

$$k_{44} = \frac{4EI_c}{h} + \frac{4EI_c}{2(2h)} = \frac{5EI_c}{h}$$

$$k_{14} = \frac{6EI_c}{h^2}, \quad k_{24} = 0$$

$$k_{34} = \frac{2EI_c}{2(2h)} = \frac{EI_c}{2h}, \quad k_{54} = \frac{2EI_c}{h}$$

$$u_5 = 1, \quad u_1 = u_2 = u_3 = u_4 = 0$$



$$k_{55} = \frac{4EI_c}{h} \quad k_{15} = \frac{6EI_c}{h^2}$$

$$k_{45} = \frac{2EI_c}{h} \quad k_{25} = k_{35} = 0$$

Assemble the stiffness coefficients:

$$k = \frac{EI_c}{h^3} \begin{bmatrix} 24 & 6h & 6h & 6h & 6h \\ 6h & 4h^2 & 2h^2 & 0 & 0 \\ 6h & 2h^2 & 5h^2 & \frac{1}{2}h^2 & 0 \\ 6h & 0 & \frac{1}{2}h^2 & 5h^2 & 2h^2 \\ 6h & 0 & 0 & 2h^2 & 4h^2 \end{bmatrix}$$

3. Determine the lateral stiffness of the frame.

First partition \mathbf{k} .

$$k = \frac{EI_c}{h^3} \begin{bmatrix} 24 & 6h & 6h & 6h & 6h \\ 6h & 4h^2 & 2h^2 & 0 & 0 \\ 6h & 2h^2 & 5h^2 & \frac{1}{2}h^2 & 0 \\ 6h & 0 & \frac{1}{2}h^2 & 5h^2 & 2h^2 \\ 6h & 0 & 0 & 2h^2 & 4h^2 \end{bmatrix} = \begin{bmatrix} \mathbf{k}_{tt} & \mathbf{k}_{t0} \\ \mathbf{k}_{t0}^T & \mathbf{k}_{00} \end{bmatrix}$$

Compute the lateral stiffness.

$$k = \mathbf{k}_{tt} - \mathbf{k}_{t0} \mathbf{k}_{00}^{-1} \mathbf{k}_{t0}^T$$

$$k = \frac{24EI_c}{h^3} - \frac{22EI_c}{h^3} = \frac{2EI_c}{h^3}$$

4. Write the equation of motion.

$$m\ddot{u} + ku = p(t)$$

$$m\ddot{u} + \left(\frac{2EI_c}{h^3} \right) u = p(t)$$

Problem 1.17

A heavy rigid platform of weight w is supported by four columns, hinged at the top and the bottom, and braced laterally in each side panel by two diagonal steel wires as shown in Fig. P1.17. Each diagonal wire is pretensioned to a high stress; its cross-sectional area is A and elastic modulus is E . Neglecting the mass of the columns and wires, derive the equation of motion governing free vibration in (a) the x -direction, and (b) the y -direction. (*Hint: Because of high pretension, all wires contribute to the structural stiffness, unlike Example 1.2, where the braces in compression do not provide stiffness.*)

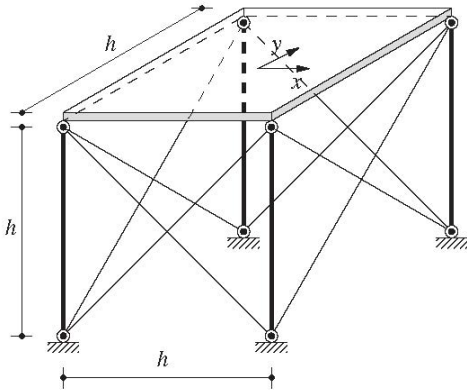

Figure P1.17

Solution:

(a) *Equation of motion in the x-direction.*

The lateral stiffness of each wire is the same as the lateral stiffness of a brace derived in Eq. (c) of Example 1.2:

$$k_w = \left(\frac{AE}{L} \right) \cos^2 \theta$$

$$= \left(\frac{AE}{h\sqrt{2}} \right) \cos^2 45^\circ = \frac{1}{2\sqrt{2}} \frac{AE}{h}$$

Each of the four sides of the structure includes two wires. If they were not pretensioned, under lateral displacement, only the wire in tension will provide lateral resistance and the one in compression will go slack and will not contribute to the lateral stiffness. However, the wires are pretensioned to a high stress; therefore, under lateral displacement the tension will increase in one wire, but decrease in the other; and both wires will contribute to the lateral direction. Consequently, four wires contribute to the stiffness in the x -direction:

$$k_x = 4k_w = \sqrt{2} \frac{AE}{h}$$

Then the equation of motion in the x -direction is

$$m\ddot{u}_x + k_x u_x = 0$$

(b) *Equation of motion in the y-direction.*

The lateral stiffness in the y -direction, $k_y = k_x$, and the same equation applies for motion in the y -direction:

$$m\ddot{u}_y + k_y u_y = 0$$

Problem 1.18

Derive the equation of motion governing the torsional vibration of the system of Fig. P1.17 about the vertical axis passing through the center of the platform.

Solution:

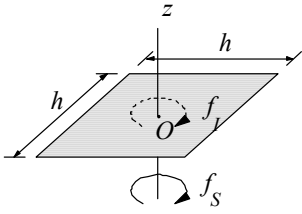

Figure P1.18a

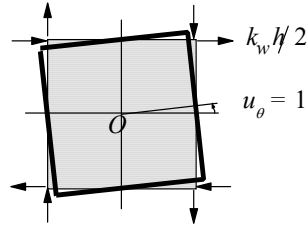

Figure P1.18b

1. Set up equation of motion.

The elastic resisting torque f_s and inertia force f_i are shown in Fig. 1.18a. The equation of dynamic equilibrium is

$$f_i + f_s = 0 \quad \text{or} \quad I_O \ddot{u}_\theta + f_s = 0 \quad (\text{a})$$

where

$$I_O = m \frac{h^2 + h^2}{12} = \frac{mh^2}{6} \quad (\text{b})$$

2. Determine torsional stiffness, k_θ .

$$f_s = k_\theta u_\theta \quad (\text{c})$$

Introduce $u_\theta = 1$ in Fig. 1.18b and identify the resisting forces due to each wire. All the eight forces are the same; each is $k_w h/2$, where, from Problem 1.17,

$$k_w = \frac{1}{2\sqrt{2}} \frac{AE}{h}$$

The torque required to equilibrate these resisting forces is

$$\begin{aligned} k_\theta &= 8k_w \frac{h}{2} \frac{h}{2} = 2k_w h^2 = \frac{2}{2\sqrt{2}} \left(\frac{AE}{h} \right) h^2 \\ &= \frac{AEh}{\sqrt{2}} \quad (\text{d}) \end{aligned}$$

3. Set up equation of motion.

Substituting Eq. (d) in (c) and then Eqs. (c) and (b) in (a) gives the equation of motion:

$$\frac{mh^2}{6} \ddot{u}_\theta + \frac{AEh}{\sqrt{2}} u_\theta = 0$$

Problem 1.19

An automobile is crudely idealized as a lumped mass m supported on a spring-damper system as shown in Fig. P1.19. The automobile travels at constant speed v over a road whose roughness is known as a function of position along the road. Derive the equation of motion.

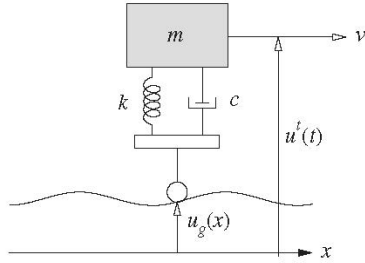

Figure P1.19

Solution:

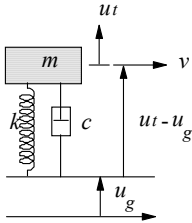

Figure P1.19a

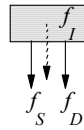

Figure P1.19b

Displacement u^t is measured from the static equilibrium position under the weight mg .

From the free-body diagram in Fig. 1.19(b)

$$f_I + f_D + f_S = 0 \quad (a)$$

where

$$f_I = m\ddot{u}^t$$

$$f_D = c(\dot{u}^t - \dot{u}_g) \quad (b)$$

$$f_S = k(u^t - u_g)$$

Substituting Eqs. (b) in Eq. (a) gives

$$m\ddot{u}^t + c(\dot{u}^t - \dot{u}_g) + k(u^t - u_g) = 0$$

Noting that $x = vt$ and transferring the excitation terms to the right side gives the equation of motion:

$$m\ddot{u}^t + c\dot{u}^t + ku^t = c\dot{u}_g(vt) + ku_g(vt)$$