

1.1 A 2-kHz sound wave traveling in the x -direction in air was observed to have a differential pressure $p(x, t) = 10 \text{ N/m}^2$ at $x = 0$ and $t = 50 \mu\text{s}$. If the reference phase of $p(x, t)$ is 36° , find a complete expression for $p(x, t)$. The velocity of sound in air is 330 m/s .

Solution: The general form is given by Eq. (1.17),

$$p(x, t) = A \cos\left(\frac{2\pi t}{T} - \frac{2\pi x}{\lambda} + \phi_0\right),$$

where it is given that $\phi_0 = 36^\circ$. From Eq. (1.26), $T = 1/f = 1/(2 \times 10^3) = 0.5 \text{ ms}$. From Eq. (1.27),

$$\lambda = \frac{u_p}{f} = \frac{330}{2 \times 10^3} = 0.165 \text{ m}.$$

Also, since

$$\begin{aligned} p(x = 0, t = 50 \mu\text{s}) &= 10 \text{ (N/m}^2\text{)} = A \cos\left(\frac{2\pi \times 50 \times 10^{-6}}{5 \times 10^{-4}} + 36^\circ \frac{\pi \text{ rad}}{180^\circ}\right) \\ &= A \cos(1.26 \text{ rad}) = 0.31A, \end{aligned}$$

it follows that $A = 10/0.31 = 32.36 \text{ N/m}^2$. So, with t in (s) and x in (m),

$$\begin{aligned} p(x, t) &= 32.36 \cos\left(2\pi \times 10^6 \frac{t}{500} - 2\pi \times 10^3 \frac{x}{165} + 36^\circ\right) \quad (\text{N/m}^2) \\ &= 32.36 \cos(4\pi \times 10^3 t - 12.12\pi x + 36^\circ) \quad (\text{N/m}^2). \end{aligned}$$

1.2 For the pressure wave described in Example 1-1, plot

(a) $p(x,t)$ versus x at $t = 0$,

(b) $p(x,t)$ versus t at $x = 0$.

Be sure to use appropriate scales for x and t so that each of your plots covers at least two cycles.

Solution: Refer to Fig. P1.2(a) and Fig. P1.2(b).

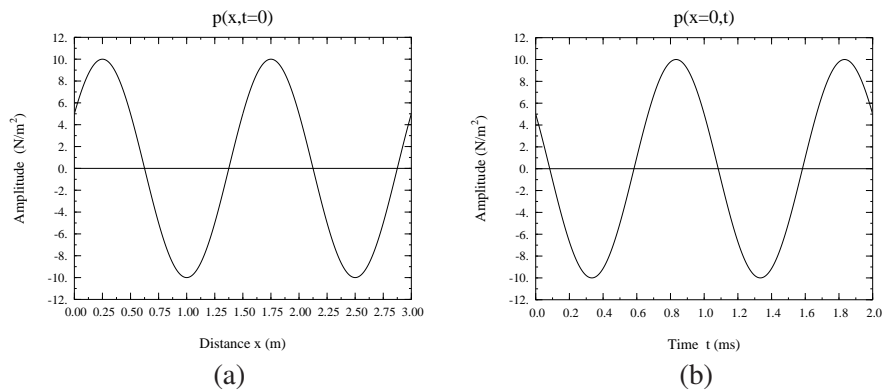

Figure P1.2 (a) Pressure wave as a function of distance at $t = 0$ and (b) pressure wave as a function of time at $x = 0$.

1.3 A harmonic wave traveling along a string is generated by an oscillator that completes 180 vibrations per minute. If it is observed that a given crest, or maximum, travels 300 cm in 10 s, what is the wavelength?

Solution:

$$f = \frac{180}{60} = 3 \text{ Hz.}$$

$$u_p = \frac{300 \text{ cm}}{10 \text{ s}} = 0.3 \text{ m/s.}$$

$$\lambda = \frac{u_p}{f} = \frac{0.3}{3} = 0.1 \text{ m} = 10 \text{ cm.}$$

1.4 A wave traveling along a string is given by

$$y(x,t) = 2 \sin(4\pi t + 10\pi x) \quad (\text{cm}),$$

where x is the distance along the string in meters and y is the vertical displacement. Determine: (a) the direction of wave travel, (b) the reference phase ϕ_0 , (c) the frequency, (d) the wavelength, and (e) the phase velocity.

Solution:

(a) We start by converting the given expression into a cosine function of the form given by (1.17):

$$y(x,t) = 2 \cos\left(4\pi t + 10\pi x - \frac{\pi}{2}\right) \quad (\text{cm}).$$

Since the coefficients of t and x both have the same sign, the wave is traveling in the negative x -direction.

(b) From the cosine expression, $\phi_0 = -\pi/2$.

(c) $\omega = 2\pi f = 4\pi$,

$$f = 4\pi/2\pi = 2 \text{ Hz}.$$

(d) $2\pi/\lambda = 10\pi$,

$$\lambda = 2\pi/10\pi = 0.2 \text{ m}.$$

(e) $u_p = f\lambda = 2 \times 0.2 = 0.4 \text{ (m/s)}$.

1.5 Two waves, $y_1(t)$ and $y_2(t)$, have identical amplitudes and oscillate at the same frequency, but $y_2(t)$ leads $y_1(t)$ by a phase angle of 60° . If

$$y_1(t) = 4 \cos(2\pi \times 10^3 t),$$

write the expression appropriate for $y_2(t)$ and plot both functions over the time span from 0 to 2 ms.

Solution:

$$y_2(t) = 4 \cos(2\pi \times 10^3 t + 60^\circ).$$

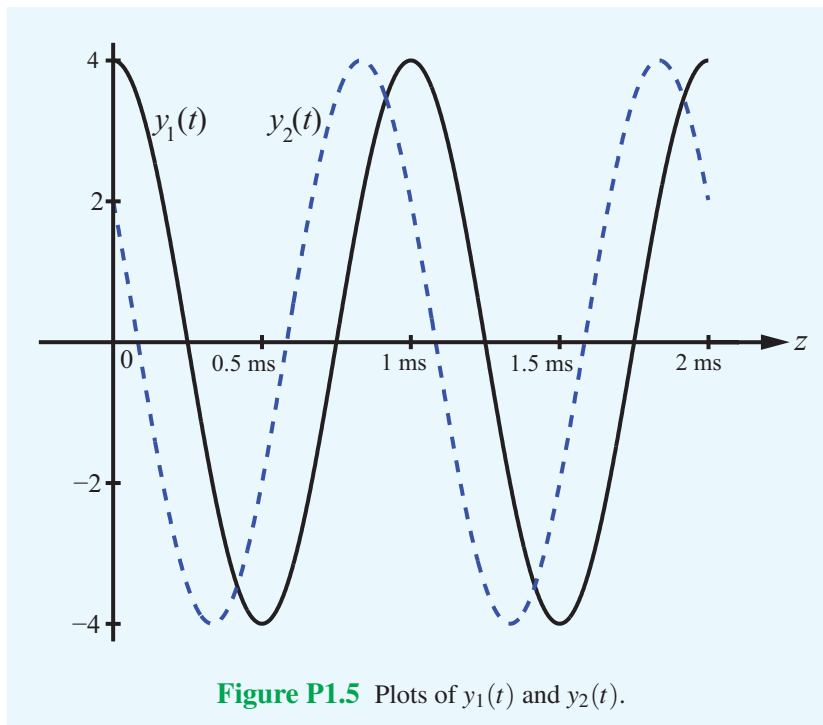

1.6 The height of an ocean wave is described by the function

$$y(x, t) = 1.5 \sin(0.5t - 0.6x) \quad (\text{m}).$$

Determine the phase velocity and the wavelength, and then sketch $y(x, t)$ at $t = 2$ s over the range from $x = 0$ to $x = 2\lambda$.

Solution: The given wave may be rewritten as a cosine function:

$$y(x, t) = 1.5 \cos(0.5t - 0.6x - \pi/2).$$

By comparison of this wave with Eq. (1.32),

$$y(x, t) = A \cos(\omega t - \beta x + \phi_0),$$

we deduce that

$$\begin{aligned} \omega = 2\pi f = 0.5 \text{ rad/s}, & \quad \beta = \frac{2\pi}{\lambda} = 0.6 \text{ rad/m}, \\ u_p = \frac{\omega}{\beta} = \frac{0.5}{0.6} = 0.83 \text{ m/s}, & \quad \lambda = \frac{2\pi}{\beta} = \frac{2\pi}{0.6} = 10.47 \text{ m}. \end{aligned}$$

At $t = 2$ s, $y(x, 2) = 1.5 \sin(1 - 0.6x)$ (m), with the argument of the cosine function given in radians. Plot is shown in **Fig. .**

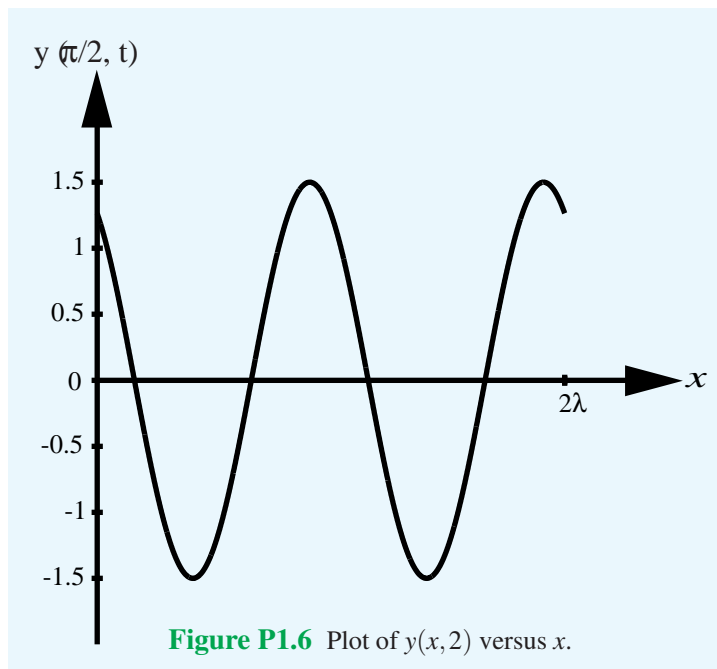

1.7 A wave traveling along a string in the $+x$ direction is given by

$$y_1(x,t) = A \cos(\omega t - \beta x),$$

where $x = 0$ is the end of the string, which is tied rigidly to a wall, as shown in Fig. P1.7. When wave $y_1(x,t)$ arrives at the wall, a reflected wave $y_2(x,t)$ is generated. Hence, at any location on the string, the vertical displacement y_s is the sum of the incident and reflected waves:

$$y_s(x,t) = y_1(x,t) + y_2(x,t).$$

- (a) Write an expression for $y_2(x,t)$, keeping in mind its direction of travel and the fact that the end of the string cannot move.
- (b) Generate plots of $y_1(x,t)$, $y_2(x,t)$ and $y_s(x,t)$ versus x over the range $-2\lambda \leq x \leq 0$ at $\omega t = \pi/4$ and at $\omega t = \pi/2$.

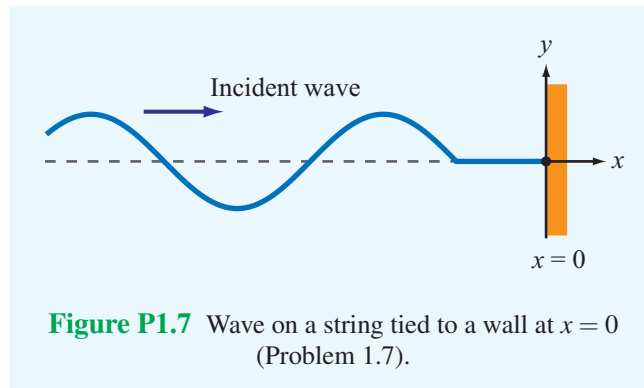

Solution:

(a) Since wave $y_2(x,t)$ was caused by wave $y_1(x,t)$, the two waves must have the same angular frequency ω , and since $y_2(x,t)$ is traveling on the same string as $y_1(x,t)$, the two waves must have the same phase constant β . Hence, with its direction being in the negative x -direction, $y_2(x,t)$ is given by the general form

$$y_2(x,t) = B \cos(\omega t + \beta x + \phi_0), \quad (1)$$

where B and ϕ_0 are yet-to-be-determined constants. The total displacement is

$$y_s(x,t) = y_1(x,t) + y_2(x,t) = A \cos(\omega t - \beta x) + B \cos(\omega t + \beta x + \phi_0).$$

Since the string cannot move at $x = 0$, the point at which it is attached to the wall, $y_s(0,t) = 0$ for all t . Thus,

$$y_s(0,t) = A \cos \omega t + B \cos(\omega t + \phi_0) = 0. \quad (2)$$

(i) Easy Solution: The physics of the problem suggests that a possible solution for (2) is $B = -A$ and $\phi_0 = 0$, in which case we have

$$y_2(x, t) = -A \cos(\omega t + \beta x). \quad (3)$$

(ii) Rigorous Solution: By expanding the second term in (2), we have

$$A \cos \omega t + B(\cos \omega t \cos \phi_0 - \sin \omega t \sin \phi_0) = 0,$$

or

$$(A + B \cos \phi_0) \cos \omega t - (B \sin \phi_0) \sin \omega t = 0. \quad (4)$$

This equation has to be satisfied for all values of t . At $t = 0$, it gives

$$A + B \cos \phi_0 = 0, \quad (5)$$

and at $\omega t = \pi/2$, (4) gives

$$B \sin \phi_0 = 0. \quad (6)$$

Equations (5) and (6) can be satisfied simultaneously only if

$$A = B = 0 \quad (7)$$

or

$$A = -B \quad \text{and} \quad \phi_0 = 0. \quad (8)$$

Clearly (7) is not an acceptable solution because it means that $y_1(x, t) = 0$, which is contrary to the statement of the problem. The solution given by (8) leads to (3).

(b) At $\omega t = \pi/4$,

$$y_1(x, t) = A \cos(\pi/4 - \beta x) = A \cos\left(\frac{\pi}{4} - \frac{2\pi x}{\lambda}\right),$$

$$y_2(x, t) = -A \cos(\omega t + \beta x) = -A \cos\left(\frac{\pi}{4} + \frac{2\pi x}{\lambda}\right).$$

Plots of y_1 , y_2 , and y_3 are shown in Fig. P1.7(b).

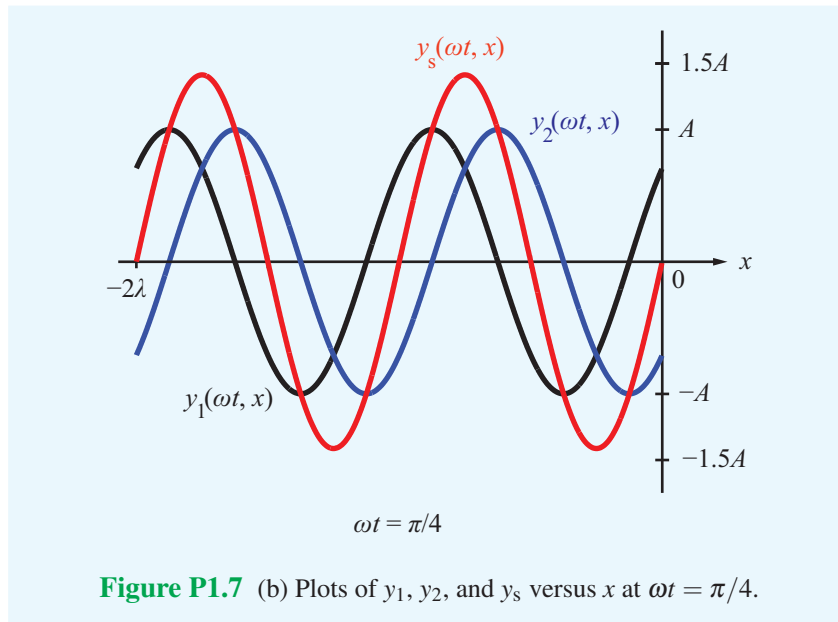

At $\omega t = \pi/2$,

$$y_1(x, t) = A \cos(\pi/2 - \beta x) = A \sin \beta x = A \sin \frac{2\pi x}{\lambda},$$

$$y_2(x, t) = -A \cos(\pi/2 + \beta x) = A \sin \beta x = A \sin \frac{2\pi x}{\lambda}.$$

Plots of y_1 , y_2 , and y_3 are shown in Fig. P1.7(c).

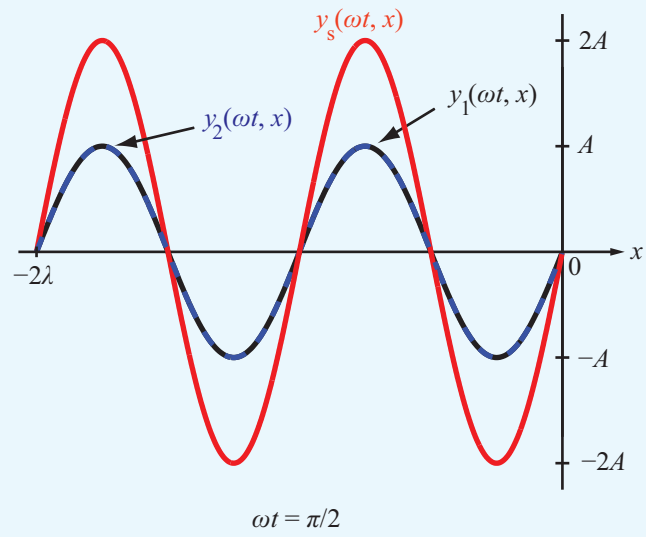

Figure P1.7 (c) Plots of y_1 , y_2 , and y_s versus x at $\omega t = \pi/2$.

1.8 Two waves on a string are given by the following functions:

$$y_1(x, t) = 4 \cos(20t - 30x) \quad (\text{cm})$$

$$y_2(x, t) = -4 \cos(20t + 30x) \quad (\text{cm})$$

where x is in centimeters. The waves are said to interfere constructively when their superposition $|y_s| = |y_1 + y_2|$ is a maximum, and they interfere destructively when $|y_s|$ is a minimum.

- (a) What are the directions of propagation of waves $y_1(x, t)$ and $y_2(x, t)$?
- (b) At $t = (\pi/50)$ s, at what location x do the two waves interfere constructively, and what is the corresponding value of $|y_s|$?
- (c) At $t = (\pi/50)$ s, at what location x do the two waves interfere destructively, and what is the corresponding value of $|y_s|$?

Solution:

(a) $y_1(x, t)$ is traveling in positive x -direction. $y_2(x, t)$ is traveling in negative x -direction.

(b) At $t = (\pi/50)$ s, $y_s = y_1 + y_2 = 4[\cos(0.4\pi - 30x) - \cos(0.4\pi + 3x)]$. Using the formulas from Appendix C,

$$2 \sin x \sin y = \cos(x - y) - \cos(x + y),$$

we have

$$y_s = 8 \sin(0.4\pi) \sin 30x = 7.61 \sin 30x.$$

Hence,

$$|y_s|_{\max} = 7.61$$

and it occurs when $|\sin 30x| = 1$, or $30x = \frac{\pi}{2} + n\pi$, or $x = \left(\frac{\pi}{60} + \frac{n\pi}{30}\right)$ cm, where $n = 0, 1, 2, \dots$.

- (c) $|y_s|_{\min} = 0$ and it occurs when $30x = n\pi$, or $x = \frac{n\pi}{30}$ cm.
-

1.9 Give expressions for $y(x,t)$ for a sinusoidal wave traveling along a string in the negative x -direction, given that $y_{\max} = 40$ cm, $\lambda = 30$ cm, $f = 10$ Hz, and

- (a) $y(x,0) = 0$ at $x = 0$,
- (b) $y(x,0) = 0$ at $x = 3.75$ cm.

Solution: For a wave traveling in the negative x -direction, we use Eq. (1.17) with $\omega = 2\pi f = 20\pi$ (rad/s), $\beta = 2\pi/\lambda = 2\pi/0.3 = 20\pi/3$ (rad/s), $A = 40$ cm, and x assigned a positive sign:

$$y(x,t) = 40 \cos \left(20\pi t + \frac{20\pi}{3}x + \phi_0 \right) \quad (\text{cm}),$$

with x in meters.

- (a) $y(0,0) = 0 = 40 \cos \phi_0$. Hence, $\phi_0 = \pm\pi/2$, and

$$\begin{aligned} y(x,t) &= 40 \cos \left(20\pi t + \frac{20\pi}{3}x \pm \frac{\pi}{2} \right) \\ &= \begin{cases} -40 \sin \left(20\pi t + \frac{20\pi}{3}x \right) \text{ (cm),} & \text{if } \phi_0 = \pi/2, \\ 40 \sin \left(20\pi t + \frac{20\pi}{3}x \right) \text{ (cm),} & \text{if } \phi_0 = -\pi/2. \end{cases} \end{aligned}$$

- (b) At $x = 3.75$ cm $= 3.75 \times 10^{-2}$ m, $y = 0 = 40 \cos(\pi/4 + \phi_0)$. Hence, $\phi_0 = \pi/4$ or $5\pi/4$, and

$$y(x,t) = \begin{cases} 40 \cos \left(20\pi t + \frac{20\pi}{3}x + \frac{\pi}{4} \right) \text{ (cm),} & \text{if } \phi_0 = \pi/4, \\ 40 \cos \left(20\pi t + \frac{20\pi}{3}x + \frac{5\pi}{4} \right) \text{ (cm),} & \text{if } \phi_0 = 5\pi/4. \end{cases}$$

1.10 An oscillator that generates a sinusoidal wave on a string completes 20 vibrations in 50 s. The wave peak is observed to travel a distance of 2.8 m along the string in 5 s. What is the wavelength?

Solution:

$$T = \frac{50}{20} = 2.5 \text{ s}, \quad u_p = \frac{2.8}{5} = 0.56 \text{ m/s},$$
$$\lambda = u_p T = 0.56 \times 2.5 = 1.4 \text{ m}.$$

1.11 The vertical displacement of a string is given by the harmonic function

$$y(x, t) = 2 \cos(16\pi t - 20\pi x) \quad (\text{m}),$$

where x is the horizontal distance along the string in meters. Suppose a tiny particle were attached to the string at $x = 5$ cm. Obtain an expression for the vertical velocity of the particle as a function of time.

Solution:

$$y(x, t) = 2 \cos(16\pi t - 20\pi x) \quad (\text{m}).$$

$$\begin{aligned} u(0.05, t) &= \left. \frac{dy(x, t)}{dt} \right|_{x=0.05} \\ &= -32\pi \sin(16\pi t - 20\pi x) \Big|_{x=0.05} \\ &= -32\pi \sin(16\pi t - \pi) \\ &= 32\pi \sin(16\pi t) \quad (\text{m/s}). \end{aligned}$$

1.12 Given two waves characterized by

$$y_1(t) = 3 \cos \omega t$$

$$y_2(t) = 3 \sin(\omega t + 60^\circ),$$

does $y_2(t)$ lead or lag $y_1(t)$ and by what phase angle?

Solution: We need to express $y_2(t)$ in terms of a cosine function:

$$\begin{aligned} y_2(t) &= 3 \sin(\omega t + 60^\circ) \\ &= 3 \cos\left(\frac{\pi}{2} - \omega t - 60^\circ\right) = 3 \cos(30^\circ - \omega t) = 3 \cos(\omega t - 30^\circ). \end{aligned}$$

Hence, $y_2(t)$ lags $y_1(t)$ by 30° .

1.13 The voltage of an electromagnetic wave traveling on a transmission line is given by $v(z,t) = 5e^{-\alpha z} \sin(4\pi \times 10^9 t - 20\pi z)$ (V), where z is the distance in meters from the generator.

(a) Find the frequency, wavelength, and phase velocity of the wave.

(b) At $z = 2$ m, the amplitude of the wave was measured to be 2 V. Find α .

Solution:

(a) This equation is similar to that of Eq. (1.28) with $\omega = 4\pi \times 10^9$ rad/s and $\beta = 20\pi$ rad/m. From Eq. (1.29a), $f = \omega/2\pi = 2 \times 10^9$ Hz = 2 GHz; from Eq. (1.29b), $\lambda = 2\pi/\beta = 0.1$ m. From Eq. (1.30),

$$u_p = \omega/\beta = 2 \times 10^8 \text{ m/s.}$$

(b) Using just the amplitude of the wave,

$$2 = 5 \exp -\alpha 2, \quad \alpha = \frac{-1}{2 \text{ m}} \ln \left(\frac{2}{5} \right) = 0.46 \text{ Np/m.}$$

1.14 A certain electromagnetic wave traveling in seawater was observed to have an amplitude of 98.02 (V/m) at a depth of 10 m, and an amplitude of 81.87 (V/m) at a depth of 100 m. What is the attenuation constant of seawater?

Solution: The amplitude has the form $Ae^{\alpha z}$. At $z = 10$ m,

$$Ae^{-10\alpha} = 98.02$$

and at $z = 100$ m,

$$Ae^{-100\alpha} = 81.87$$

The ratio gives

$$\frac{e^{-10\alpha}}{e^{-100\alpha}} = \frac{98.02}{81.87} = 1.20$$

or

$$e^{-10\alpha} = 1.2e^{-100\alpha}.$$

Taking the natural log of both sides gives

$$\begin{aligned}\ln(e^{-10\alpha}) &= \ln(1.2e^{-100\alpha}), \\ -10\alpha &= \ln(1.2) - 100\alpha, \\ 90\alpha &= \ln(1.2) = 0.18.\end{aligned}$$

Hence,

$$\alpha = \frac{0.18}{90} = 2 \times 10^{-3} \quad (\text{Np/m}).$$

1.15 A laser beam traveling through fog was observed to have an intensity of 1 ($\mu\text{W}/\text{m}^2$) at a distance of 2 m from the laser gun and an intensity of 0.2 ($\mu\text{W}/\text{m}^2$) at a distance of 3 m. Given that the intensity of an electromagnetic wave is proportional to the square of its electric-field amplitude, find the attenuation constant α of fog.

Solution: If the electric field is of the form

$$E(x, t) = E_0 e^{-\alpha x} \cos(\omega t - \beta x),$$

then the intensity must have a form

$$\begin{aligned} I(x, t) &\approx [E_0 e^{-\alpha x} \cos(\omega t - \beta x)]^2 \\ &\approx E_0^2 e^{-2\alpha x} \cos^2(\omega t - \beta x) \end{aligned}$$

or

$$I(x, t) = I_0 e^{-2\alpha x} \cos^2(\omega t - \beta x)$$

where we define $I_0 \approx E_0^2$. We observe that the magnitude of the intensity varies as $I_0 e^{-2\alpha x}$. Hence,

$$\text{at } x = 2 \text{ m, } \quad I_0 e^{-4\alpha} = 1 \times 10^{-6} \quad (\text{W}/\text{m}^2),$$

$$\text{at } x = 3 \text{ m, } \quad I_0 e^{-6\alpha} = 0.2 \times 10^{-6} \quad (\text{W}/\text{m}^2).$$

$$\frac{I_0 e^{-4\alpha}}{I_0 e^{-6\alpha}} = \frac{10^{-6}}{0.2 \times 10^{-6}} = 5$$

$$e^{-4\alpha} \cdot e^{6\alpha} = e^{2\alpha} = 5$$

$$\alpha = 0.8 \quad (\text{NP}/\text{m}).$$

1.16 Evaluate each of the following complex numbers and express the result in rectangular form:

(a) $z_1 = 8e^{j\pi/3}$

(b) $z_2 = \sqrt{3} e^{j3\pi/4}$

(c) $z_3 = 2e^{-j\pi/2}$

(d) $z_4 = j^3$

(e) $z_5 = j^{-4}$

(f) $z_6 = (1 - j)^3$

(g) $z_7 = (1 - j)^{1/2}$

Solution: (Note: In the following solutions, numbers are expressed to only two decimal places, but the final answers are found using a calculator with 10 decimal places.)

(a) $z_1 = 8e^{j\pi/3} = 8(\cos \pi/3 + j \sin \pi/3) = 4.0 + j6.93.$

(b)

$$z_2 = \sqrt{3} e^{j3\pi/4} = \sqrt{3} \left[\cos \left(\frac{3\pi}{4} \right) + j \sin \left(\frac{3\pi}{4} \right) \right] = -1.22 + j1.22 = 1.22(-1 + j).$$

(c) $z_3 = 2e^{-j\pi/2} = 2[\cos(-\pi/2) + j \sin(-\pi/2)] = -j2.$

(d) $z_4 = j^3 = j \cdot j^2 = -j, \text{ or}$

$$z_4 = j^3 = (e^{j\pi/2})^3 = e^{j3\pi/2} = \cos(3\pi/2) + j \sin(3\pi/2) = -j.$$

(e) $z_5 = j^{-4} = (e^{j\pi/2})^{-4} = e^{-j2\pi} = 1.$

(f)

$$\begin{aligned} z_6 &= (1 - j)^3 = (\sqrt{2} e^{-j\pi/4})^3 = (\sqrt{2})^3 e^{-j3\pi/4} \\ &= (\sqrt{2})^3 [\cos(3\pi/4) - j \sin(3\pi/4)] \\ &= -2 - j2 = -2(1 + j). \end{aligned}$$

(g)

$$\begin{aligned} z_7 &= (1 - j)^{1/2} = (\sqrt{2} e^{-j\pi/4})^{1/2} = \pm 2^{1/4} e^{-j\pi/8} = \pm 1.19(0.92 - j0.38) \\ &= \pm(1.10 - j0.45). \end{aligned}$$

1.17 Complex numbers z_1 and z_2 are given by

$$z_1 = 3 - j2$$

$$z_2 = -4 + j3$$

- (a) Express z_1 and z_2 in polar form.
- (b) Find $|z_1|$ by first applying Eq. (1.41) and then by applying Eq. (1.43).
- (c) Determine the product $z_1 z_2$ in polar form.
- (d) Determine the ratio z_1/z_2 in polar form.
- (e) Determine z_1^3 in polar form.

Solution:

- (a) Using Eq. (1.41),

$$z_1 = 3 - j2 = 3.6 \exp -j33.7^\circ,$$

$$z_2 = -4 + j3 = 5 \exp j143.1^\circ.$$

- (b) By Eq. (1.41) and Eq. (1.43), respectively,

$$|z_1| = |3 - j2| = \sqrt{3^2 + (-2)^2} = \sqrt{13} = 3.60,$$

$$|z_1| = \sqrt{(3 - j2)(3 + j2)} = \sqrt{13} = 3.60.$$

- (c) By applying Eq. (1.47b) to the results of part (a),

$$z_1 z_2 = 3.6 \exp -j33.7^\circ \times 5 \exp j143.1^\circ = 18 \exp j109.4^\circ.$$

- (d) By applying Eq. (1.48b) to the results of part (a),

$$\frac{z_1}{z_2} = \frac{3.6 \exp -j33.7^\circ}{5 \exp j143.1^\circ} = 0.72 \exp -j176.8^\circ.$$

- (e) By applying Eq. (1.49) to the results of part (a),

$$z_1^3 = (3.6 \exp -j33.7^\circ)^3 = (3.6)^3 \exp -j3 \times 33.7^\circ = 46.66 \exp -j101.1^\circ.$$

1.18 Complex numbers z_1 and z_2 are given by

$$z_1 = -3 + j2$$

$$z_2 = 1 - j2$$

Determine (a) $z_1 z_2$, (b) z_1/z_2^* , (c) z_1^2 , and (d) $z_1 z_1^*$, all in polar form.

Solution:

(a) We first convert z_1 and z_2 to polar form:

$$\begin{aligned} z_1 &= -(3 - j2) = -\left(\sqrt{3^2 + 2^2} e^{-j \tan^{-1} 2/3}\right) \\ &= -\sqrt{13} e^{-j33.7^\circ} \\ &= \sqrt{13} e^{j(180^\circ - 33.7^\circ)} \\ &= \sqrt{13} e^{j146.3^\circ}. \end{aligned}$$

$$\begin{aligned} z_2 &= 1 - j2 = \sqrt{1+4} e^{-j \tan^{-1} 2} \\ &= \sqrt{5} e^{-j63.4^\circ}. \end{aligned}$$

$$\begin{aligned} z_1 z_2 &= \sqrt{13} e^{j146.3^\circ} \times \sqrt{5} e^{-j63.4^\circ} \\ &= \sqrt{65} e^{j82.9^\circ}. \end{aligned}$$

(b)

$$\frac{z_1}{z_2^*} = \frac{\sqrt{13} e^{j146.3^\circ}}{\sqrt{5} e^{j63.4^\circ}} = \sqrt{\frac{13}{5}} e^{j82.9^\circ}.$$

(c)

$$\begin{aligned} z_1^2 &= (\sqrt{13})^2 (e^{j146.3^\circ})^2 = 13 e^{j292.6^\circ} \\ &= 13 e^{-j360^\circ} e^{j292.6^\circ} \\ &= 13 e^{-j67.4^\circ}. \end{aligned}$$

(d)

$$\begin{aligned} z_1 z_1^* &= \sqrt{13} e^{j146.3^\circ} \times \sqrt{13} e^{-j146.3^\circ} \\ &= 13. \end{aligned}$$

1.19 If $z = -2 + j4$, determine the following quantities in polar form:

- (a) $1/z$,
- (b) z^3 ,
- (c) $|z|^2$,
- (d) $\Im\{z\}$,
- (e) $\Im\{z^*\}$.

Solution: (Note: In the following solutions, numbers are expressed to only two decimal places, but the final answers are found using a calculator with 10 decimal places.)

(a)

$$\frac{1}{z} = \frac{1}{-2 + j4} = (-2 + j4)^{-1} = (4.47 e^{j116.6^\circ})^{-1} = (4.47)^{-1} e^{-j116.6^\circ} = 0.22 e^{-j116.6^\circ}.$$

$$(b) z^3 = (-2 + j4)^3 = (4.47 e^{j116.6^\circ})^3 = (4.47)^3 e^{j350.0^\circ} = 89.44 e^{-j10^\circ}.$$

$$(c) |z|^2 = z \cdot z^* = (-2 + j4)(-2 - j4) = 4 + 16 = 20.$$

$$(d) \Im\{z\} = \Im\{-2 + j4\} = 4.$$

$$(e) \Im\{z^*\} = \Im\{-2 - j4\} = -4 = 4e^{j\pi}.$$

1.20 Find complex numbers $t = z_1 + z_2$ and $s = z_1 - z_2$, both in polar form, for each of the following pairs:

(a) $z_1 = 2 + j3$ and $z_2 = 1 - j2$,

(b) $z_1 = 3$ and $z_2 = -j3$,

(c) $z_1 = 3\angle 30^\circ$ and $z_2 = 3\angle -30^\circ$,

(d) $z_1 = 3\angle 30^\circ$ and $z_2 = 3\angle -150^\circ$.

Solution:

(a)

$$t = z_1 + z_2 = (2 + j3) + (1 - j2) = 3 + j1,$$

$$s = z_1 - z_2 = (2 + j3) - (1 - j2) = 1 + j5 = 5.1 e^{j78.7^\circ}.$$

(b)

$$t = z_1 + z_2 = 3 - j3 = 4.24 e^{-j45^\circ},$$

$$s = z_1 - z_2 = 3 + j3 = 4.24 e^{j45^\circ}.$$

(c)

$$t = z_1 + z_2 = 3\angle 30^\circ + 3\angle -30^\circ$$

$$= 3e^{j30^\circ} + 3e^{-j30^\circ} = (2.6 + j1.5) + (2.6 - j1.5) = 5.2,$$

$$s = z_1 - z_2 = 3e^{j30^\circ} - 3e^{-j30^\circ} = (2.6 + j1.5) - (2.6 - j1.5) = j3 = 3e^{j90^\circ}.$$

(d)

$$t = z_1 + z_2 = 3\angle 30^\circ + 3\angle -150^\circ = (2.6 + j1.5) + (-2.6 - j1.5) = 0,$$

$$s = z_1 - z_2 = (2.6 + j1.5) - (-2.6 - j1.5) = 5.2 + j3 = 6e^{j30^\circ}.$$

1.21 Complex numbers z_1 and z_2 are given by

$$z_1 = 5\angle -60^\circ$$

$$z_2 = 4\angle 45^\circ.$$

- (a) Determine the product $z_1 z_2$ in polar form.
- (b) Determine the product $z_1 z_2^*$ in polar form.
- (c) Determine the ratio z_1/z_2 in polar form.
- (d) Determine the ratio z_1^*/z_2^* in polar form.
- (e) Determine $\sqrt{z_1}$ in polar form.

Solution:

(a) $z_1 z_2 = 5e^{-j60^\circ} \times 4e^{j45^\circ} = 20e^{-j15^\circ}.$

(b) $z_1 z_2^* = 5e^{-j60^\circ} \times 4e^{-j45^\circ} = 20e^{-j105^\circ}.$

(c) $\frac{z_1}{z_2} = \frac{5e^{-j60^\circ}}{4e^{j45^\circ}} = 1.25e^{-j105^\circ}.$

(d) $\frac{z_1^*}{z_2^*} = \left(\frac{z_1}{z_2}\right)^* = 1.25e^{j105^\circ}.$

(e) $\sqrt{z_1} = \sqrt{5e^{-j60^\circ}} = \pm\sqrt{5}e^{-j30^\circ}.$

1.22 If $z = 3 - j5$, find the value of $\ln(z)$.

Solution:

$$|z| = +\sqrt{3^2 + 5^2} = 5.83, \quad \theta = \tan^{-1}\left(\frac{-5}{3}\right) = -59^\circ,$$

$$z = |z|e^{j\theta} = 5.83e^{-j59^\circ},$$

$$\ln(z) = \ln(5.83e^{-j59^\circ})$$

$$= \ln(5.83) + \ln(e^{-j59^\circ})$$

$$= 1.76 - j59^\circ = 1.76 - j\frac{59^\circ\pi}{180^\circ} = 1.76 - j1.03.$$

1.23 If $z = 3 - j4$, find the value of e^z .

Solution:

$$e^z = e^{3-j4} = e^3 \cdot e^{-j4} = e^3(\cos 4 - j \sin 4),$$
$$e^3 = 20.09, \quad \text{and} \quad 4 \text{ rad} = \frac{4}{\pi} \times 180^\circ = 229.18^\circ.$$

Hence, $e^z = 20.08(\cos 229.18^\circ - j \sin 229.18^\circ) = -13.13 + j15.20$.

1.24 If $z = 3e^{j\pi/6}$, find the value of e^z .

Solution:

$$\begin{aligned}z &= 3e^{j\pi/6} = 3 \cos \pi/6 + j3 \sin \pi/6 \\ &= 2.6 + j1.5\end{aligned}$$

$$\begin{aligned}e^z &= e^{2.6+j1.5} = e^{2.6} \times e^{j1.5} \\ &= e^{2.6}(\cos 1.5 + j \sin 1.5) \\ &= 13.46(0.07 + j0.98) \\ &= 0.95 + j13.43.\end{aligned}$$

1.25 A voltage source given by

$$v_s(t) = 25 \cos(2\pi \times 10^3 t - 30^\circ) \quad (\text{V})$$

is connected to a series RC load as shown in Fig. 1-20. If $R = 1 \text{ M}\Omega$ and $C = 200 \text{ pF}$, obtain an expression for $v_c(t)$, the voltage across the capacitor.

Solution: In the phasor domain, the circuit is a voltage divider, and

$$\tilde{V}_c = \tilde{V}_s \frac{1/j\omega C}{R + 1/j\omega C} = \frac{\tilde{V}_s}{(1 + j\omega RC)}.$$

Now $\tilde{V}_s = 25 \exp -j30^\circ \text{ V}$ with $\omega = 2\pi \times 10^3 \text{ rad/s}$, so

$$\begin{aligned} \tilde{V}_c &= \frac{25 \exp -j30^\circ \text{ V}}{1 + j((2\pi \times 10^3 \text{ rad/s}) \times (10^6 \Omega) \times (200 \times 10^{-12} \text{ F}))} \\ &= \frac{25 \exp -j30^\circ \text{ V}}{1 + j2\pi/5} = 15.57 \exp -j81.5^\circ \text{ V}. \end{aligned}$$

Converting back to an instantaneous value,

$$v_c(t) = \Re \tilde{V}_c \exp j\omega t = \Re 15.57 \exp j(\omega t - 81.5^\circ) \text{ V} = 15.57 \cos(2\pi \times 10^3 t - 81.5^\circ) \text{ V},$$

where t is expressed in seconds.

1.26 Find the phasors of the following time functions:

- (a) $v(t) = 9 \cos(\omega t - \pi/3)$ (V)
- (b) $v(t) = 12 \sin(\omega t + \pi/4)$ (V)
- (c) $i(x, t) = 5e^{-3x} \sin(\omega t + \pi/6)$ (A)
- (d) $i(t) = -2 \cos(\omega t + 3\pi/4)$ (A)
- (e) $i(t) = 4 \sin(\omega t + \pi/3) + 3 \cos(\omega t - \pi/6)$ (A)

Solution:

(a) $\tilde{V} = 9 \exp -j\pi/3$ V.

(b) $v(t) = 12 \sin(\omega t + \pi/4) = 12 \cos(\pi/2 - (\omega t + \pi/4)) = 12 \cos(\omega t - \pi/4)$ V,
 $\tilde{V} = 12 \exp -j\pi/4$ V.

(c)

$$\begin{aligned} i(t) &= 5 \exp -3x \sin(\omega t + \pi/6) \text{ A} = 5 \exp -3x \cos[\pi/2 - (\omega t + \pi/6)] \text{ A} \\ &= 5 \exp -3x \cos(\omega t - \pi/3) \text{ A}, \\ \tilde{I} &= 5 \exp -3x \exp -j\pi/3 \text{ A}. \end{aligned}$$

(d)

$$\begin{aligned} i(t) &= -2 \cos(\omega t + 3\pi/4), \\ \tilde{I} &= -2e^{j3\pi/4} = 2e^{-j\pi} e^{j3\pi/4} = 2e^{-j\pi/4} \text{ A}. \end{aligned}$$

(e)

$$\begin{aligned} i(t) &= 4 \sin(\omega t + \pi/3) + 3 \cos(\omega t - \pi/6) \\ &= 4 \cos[\pi/2 - (\omega t + \pi/3)] + 3 \cos(\omega t - \pi/6) \\ &= 4 \cos(-\omega t + \pi/6) + 3 \cos(\omega t - \pi/6) \\ &= 4 \cos(\omega t - \pi/6) + 3 \cos(\omega t - \pi/6) = 7 \cos(\omega t - \pi/6), \\ \tilde{I} &= 7e^{-j\pi/6} \text{ A}. \end{aligned}$$

1.27 Find the instantaneous time sinusoidal functions corresponding to the following phasors:

- (a) $\tilde{V} = -5e^{j\pi/3}$ (V)
- (b) $\tilde{V} = j6e^{-j\pi/4}$ (V)
- (c) $\tilde{I} = (6 + j8)$ (A)
- (d) $\tilde{I} = -3 + j2$ (A)
- (e) $\tilde{I} = j$ (A)
- (f) $\tilde{I} = 2e^{j\pi/6}$ (A)

Solution:

(a)

$$\begin{aligned}\tilde{V} &= -5 \exp j\pi/3 \text{ V} = 5 \exp j(\pi/3 - \pi) \text{ V} = 5 \exp -j2\pi/3 \text{ V}, \\ v(t) &= 5 \cos(\omega t - 2\pi/3) \text{ V}.\end{aligned}$$

(b)

$$\begin{aligned}\tilde{V} &= j6 \exp -j\pi/4 \text{ V} = 6 \exp j(-\pi/4 + \pi/2) \text{ V} = 6 \exp j\pi/4 \text{ V}, \\ v(t) &= 6 \cos(\omega t + \pi/4) \text{ V}.\end{aligned}$$

(c)

$$\begin{aligned}\tilde{I} &= (6 + j8) \text{ A} = 10 \exp j53.1^\circ \text{ A}, \\ i(t) &= 10 \cos(\omega t + 53.1^\circ) \text{ A}.\end{aligned}$$

(d)

$$\begin{aligned}\tilde{I} &= -3 + j2 = 3.61 e^{j146.31^\circ}, \\ i(t) &= \Re\{3.61 e^{j146.31^\circ} e^{j\omega t}\} = 3.61 \cos(\omega t + 146.31^\circ) \text{ A}.\end{aligned}$$

(e)

$$\begin{aligned}\tilde{I} &= j = e^{j\pi/2}, \\ i(t) &= \Re\{e^{j\pi/2} e^{j\omega t}\} = \cos(\omega t + \pi/2) = -\sin \omega t \text{ A}.\end{aligned}$$

(f)

$$\begin{aligned}\tilde{I} &= 2e^{j\pi/6}, \\ i(t) &= \Re\{2e^{j\pi/6} e^{j\omega t}\} = 2 \cos(\omega t + \pi/6) \text{ A}.\end{aligned}$$

1.28 A series RLC circuit is connected to a generator with a voltage $v_s(t) = V_0 \cos(\omega t + \pi/3)$ (V).

- (a) Write the voltage loop equation in terms of the current $i(t)$, R , L , C , and $v_s(t)$.
- (b) Obtain the corresponding phasor-domain equation.
- (c) Solve the equation to obtain an expression for the phasor current \tilde{I} .

Solution:

(a) $v_s(t) = Ri + L \frac{di}{dt} + \frac{1}{C} \int i dt.$

(b) In phasor domain: $\tilde{V}_s = R\tilde{I} + j\omega L\tilde{I} + \frac{\tilde{I}}{j\omega C}.$

(c) $\tilde{I} = \frac{\tilde{V}_s}{R + j(\omega L - 1/\omega C)} = \frac{V_0 e^{j\pi/3}}{R + j(\omega L - 1/\omega C)} = \frac{\omega C V_0 e^{j\pi/3}}{\omega RC + j(\omega^2 LC - 1)}.$

1.29 The voltage source of the circuit shown in Fig. P1.29 is given by

$$v_s(t) = 25 \cos(4 \times 10^4 t - 45^\circ) \quad (\text{V}).$$

Obtain an expression for $i_L(t)$, the current flowing through the inductor.

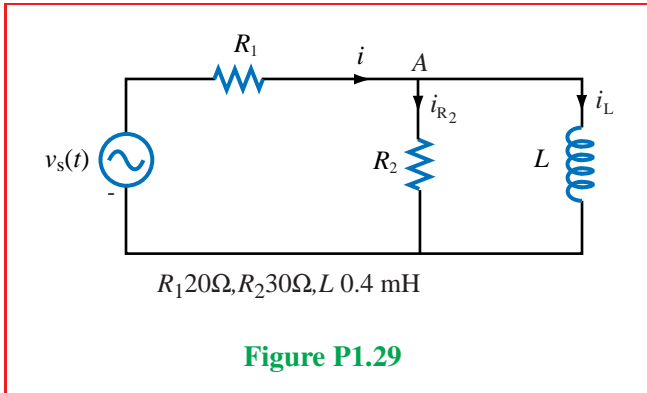

Solution: Based on the given voltage expression, the phasor source voltage is

$$\tilde{V}_s = 25e^{-j45^\circ} \quad (\text{V}). \quad (9)$$

The voltage equation for the left-hand side loop is

$$R_1 i + R_2 i_{R_2} = v_s \quad (10)$$

For the right-hand loop,

$$R_2 i_{R_2} = L \frac{di_L}{dt}, \quad (11)$$

and at node A,

$$i = i_{R_2} + i_L. \quad (12)$$

Next, we convert Eqs. (2)–(4) into phasor form:

$$R_1 \tilde{I} + R_2 \tilde{I}_{R_2} = \tilde{V}_s \quad (13)$$

$$R_2 \tilde{I}_{R_2} = j\omega L \tilde{I}_L \quad (14)$$

$$\tilde{I} = \tilde{I}_{R_2} + \tilde{I}_L \quad (15)$$

Upon combining (6) and (7) to solve for \tilde{I}_{R_2} in terms of \tilde{I} , we have:

$$\tilde{I}_{R_2} = \frac{j\omega L}{R_2 + j\omega L} \tilde{I}. \quad (16)$$

Substituting (8) in (5) and then solving for \tilde{I} leads to:

$$\begin{aligned}
 R_1\tilde{I} + \frac{jR_2\omega L}{R_2 + j\omega L}\tilde{I} &= \tilde{V}_s \\
 \tilde{I}\left(R_1 + \frac{jR_2\omega L}{R_2 + j\omega L}\right) &= \tilde{V}_s \\
 \tilde{I}\left(\frac{R_1R_2 + jR_1\omega L + jR_2\omega L}{R_2 + j\omega L}\right) &= \tilde{V}_s \\
 \tilde{I} &= \left(\frac{R_2 + j\omega L}{R_1R_2 + j\omega L(R_1 + R_2)}\right)\tilde{V}_s.
 \end{aligned} \tag{17}$$

Combining (6) and (7) to solve for \tilde{I}_L in terms of \tilde{I} gives

$$\tilde{I}_L = \frac{R_2}{R_2 + j\omega L}\tilde{I}. \tag{18}$$

Combining (9) and (10) leads to

$$\begin{aligned}
 \tilde{I}_L &= \left(\frac{R_2}{R_2 + j\omega L}\right)\left(\frac{R_2 + j\omega L}{R_1R_2 + j\omega L(R_1 + R_2)}\right)\tilde{V}_s \\
 &= \frac{R_2}{R_1R_2 + j\omega L(R_1 + R_2)}\tilde{V}_s.
 \end{aligned}$$

Using (1) for \tilde{V}_s and replacing R_1 , R_2 , L and ω with their numerical values, we have

$$\begin{aligned}
 \tilde{I}_L &= \frac{30}{20 \times 30 + j4 \times 10^4 \times 0.4 \times 10^{-3}(20 + 30)} 25e^{-j45^\circ} \\
 &= \frac{30 \times 25}{600 + j800} e^{-j45^\circ} \\
 &= \frac{7.5}{6 + j8} e^{-j45^\circ} = \frac{7.5e^{-j45^\circ}}{10e^{j53.1^\circ}} = 0.75e^{-j98.1^\circ} \quad (\text{A}).
 \end{aligned}$$

Finally,

$$\begin{aligned}
 i_L(t) &= \Re\{[\tilde{I}_L e^{j\omega t}]\} \\
 &= 0.75 \cos(4 \times 10^4 t - 98.1^\circ) \quad (\text{A}).
 \end{aligned}$$