

## Sections 1.2-1.3: Charge, Current, and Kirchhoff's Current Law; Voltage and Kirchhoff's Voltage Law

### Problem 1.1

A free electron has an initial potential energy per unit charge (voltage) of 17 kJ/C and a velocity of 93 Mm/s. Later, its potential energy per unit charge is 6 kJ/C. Determine the change in velocity of the electron.

#### Solution:

#### Known quantities:

Initial Coulombic potential energy,  $V_i = 17 \text{ kJ/C}$ ; initial velocity,  $U_i = 93 \text{ M} \frac{\text{m}}{\text{s}}$ ; final Coulombic potential energy,  $V_f = 6 \text{ kJ/C}$ .

#### Find:

The change in velocity of the electron.

#### Assumptions:

$$\Delta PE_g \ll \Delta PE_c$$

#### Analysis:

Using the first law of thermodynamics, we obtain the final velocity of the electron:

$$Q_{\text{heat}} - W = \Delta KE + \Delta PE_c + \Delta PE_g + \dots$$

Heat is not applicable to a single particle.  $W=0$  since no external forces are applied.

$$\Delta KE = -\Delta PE_c$$

$$\frac{1}{2} m_e (U_f^2 - U_i^2) = -Q_e (V_f - V_i)$$

$$U_f^2 = U_i^2 - \frac{2Q_e}{m_e} (V_f - V_i)$$

$$= \left( 93 \text{ M} \frac{\text{m}}{\text{s}} \right)^2 - \frac{2(-1.6 \times 10^{-19} \text{ C})}{9.11 \times 10^{-37} \text{ g}} (6 \text{ kV} - 17 \text{ kV})$$

$$= 8.649 \times 10^{15} \frac{\text{m}^2}{\text{s}^2} - 3.864 \times 10^{15} \frac{\text{m}^2}{\text{s}^2}$$

$$U_f = 6.917 \times 10^7 \frac{\text{m}}{\text{s}}$$

$$|U_f - U_i| = 93 \text{ M} \frac{\text{m}}{\text{s}} - 69.17 \text{ M} \frac{\text{m}}{\text{s}} = 23.83 \text{ M} \frac{\text{m}}{\text{s}}$$

## Problem 1.2

The units for voltage, current, and resistance are the volt (V), the ampere (A), and the ohm ( $\Omega$ ), respectively. Express each unit in fundamental MKS units.

### **Solution:**

#### **Known quantities:**

MKSQ units.

#### **Find:**

Equivalent units of volt, ampere and ohm.

#### **Analysis:**

$$\text{Voltage} = \text{Volt} = \frac{\text{Joule}}{\text{Coulomb}} \quad V = \frac{J}{C}$$

$$\text{Current} = \text{Ampere} = \frac{\text{Coulomb}}{\text{second}} \quad a = \frac{C}{s}$$

$$\text{Resistance} = \text{Ohm} = \frac{\text{Volt}}{\text{Ampere}} = \frac{\text{Joule} \times \text{second}}{\text{Coulomb}^2} \quad \Omega = \frac{J \cdot s}{C^2}$$

$$\text{Conductance} = \text{Siemens or Mho} = \frac{\text{Ampere}}{\text{Volt}} = \frac{C^2}{J \cdot s}$$

---

## Problem 1.3

A particular fully charged battery can deliver  $2.7 \times 10^6$  coulombs of charge.

- What is the capacity of the battery in ampere-hours?
- How many electrons can be delivered?

### **Solution:**

#### **Known quantities:**

$$q_{\text{Battery}} = 2.7 \cdot 10^6 \text{ C.}$$

#### **Find:**

The current capacity of the battery in ampere-hours

The number of electrons that can be delivered.

#### **Analysis:**

There are 3600 seconds in one hour. Amperage is defined as 1 Coulomb per second and is directly proportional to ampere-hours.

$$2.7 \cdot 10^6 \text{ C} \cdot \frac{1 \text{ hr}}{3600 \text{ s}} = 750 \text{ AH}$$

- a) The charge of a single electron is  $-1.602 \cdot 10^{-19}$  C. The negative sign is negligible. Simple division gives the solution:

$$2.7 \cdot 10^6 \text{ C} / \frac{1.602 \cdot 10^{-19} \text{ C}}{1 \text{ electron}} = 1.685 \cdot 10^{25} \text{ electrons}$$

---

## Problem 1.4

The charge cycle shown in Figure P1.4 is an example of a three-rate charge. The current is held constant at 30 mA for 6 h. Then it is switched to 20 mA for the next 3 h. Find:

- The total charge transferred to the battery.
- The energy transferred to the battery.

Hint: Recall that energy  $w$  is the integral of power, or  $P = dw/dt$ .

### Solution:

#### Known quantities:

See Figure P1.4

#### Find:

- The total charge transferred to the battery.
- The energy transferred to the battery.

#### Analysis:

Current is equal to  $\frac{\text{Coulombs}}{\text{Second}}$ , therefore given the current and a duration of that current, the transferred charge can be calculated by the following equation:

$$A \cdot t = C$$

The two durations should be calculated independently and then added together.

$$0.030A \cdot 21600s = 648C$$

$$0.020A \cdot 10800s = 216C$$

$$648C + 216C = \mathbf{864C}$$

$P=V \cdot I$ , therefore, an equation for power can be found by multiplying the two graphs together.

First separate the voltage graph into three equations:

$$0 \text{ h} \rightarrow 3 \text{ h} : V = 9.26 \cdot 10^{-6}t + 0.5$$

$$3 \text{ h} \rightarrow 6 \text{ h} : V = 5.55 \cdot 10^{-5}t$$

$$6 \text{ h} \rightarrow 9 \text{ h} : V = 1.11 \cdot 10^{-4}t - 1.6$$

Next, multiply the first two equations by 0.03A and the third by 0.02A.

$$0 \text{ h} \rightarrow 3 \text{ h} : P = 2.77 \cdot 10^{-7}t + 0.015$$

$$3 \text{ h} \rightarrow 6 \text{ h} : P = 1.66 \cdot 10^{-6}t$$

$$6 \text{ h} \rightarrow 9 \text{ h} : P = 2.22 \cdot 10^{-6}t - 0.032$$

Finally, since Energy is equal to the integral of power, take the integral of each of the equations for their specified times and add them together.

$$0 \text{ h} \rightarrow 3 \text{ h} : E = \left[ \frac{2.77 \cdot 10^{-7}t^2}{2} + 0.015t \right] \Big|_0^{10800} = 178.2 \text{ J}$$

$$3 \text{ h} \rightarrow 6 \text{ h} : E = \left[ \frac{1.66 \cdot 10^{-6}t^2}{2} \right] \Big|_{10800}^{21600} = 290.43 \text{ J}$$

$$6 \text{ h} \rightarrow 9 \text{ h} : E = \left[ \frac{2.22 \cdot 10^{-6}t^2}{2} + 0.032t \right] \Big|_{21600}^{32400} = 992.95 \text{ J}$$

$$E_{\text{Total}} = \mathbf{1462 \text{ J}}$$

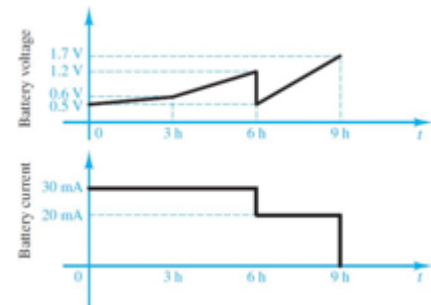

---

## Problem 1.5

Batteries (e.g., lead-acid batteries) store chemical energy and convert it to electric energy on demand. Batteries do not store electric charge or charge carriers. Charge carriers (electrons) enter one terminal of the battery, acquire electrical potential energy, and exit from the other terminal at a lower voltage. Remember the electron has a negative charge! It is convenient to think of positive carriers flowing in the opposite direction, that is, conventional current, and exiting at a higher voltage. All currents in this course, unless otherwise stated, are conventional current. (Benjamin Franklin caused this mess!) For a battery with a rated voltage = 12 V and a rated capacity = 350 A-h, determine

- The rated chemical energy stored in the battery.
- The total charge that can be supplied at the rated

### **Solution:**

#### **Known quantities:**

Rated voltage of the battery; rated capacity of the battery.

#### **Find:**

The rated chemical energy stored in the battery  
The total charge that can be supplied at the rated voltage.

#### **Analysis:**

a)

$$\Delta V \equiv \frac{\Delta PE_c}{\Delta Q} \quad I = \frac{\Delta Q}{\Delta t}$$

$$\text{Chemical energy} = \Delta PE_c = \Delta V \cdot \Delta Q = \Delta V \cdot (I \cdot \Delta t)$$

$$= 12 \text{ V} \cdot 350 \text{ A} \cdot \text{hr} \cdot 3600 \frac{\text{s}}{\text{hr}} = 15.12 \text{ MJ.}$$

As the battery discharges, the voltage will decrease below the rated voltage. The remaining chemical energy stored in the battery is less useful or not useful.

b)  $\Delta Q$  is the total charge passing through the battery and gaining 12 J/C of electrical energy.

$$\Delta Q = I \cdot \Delta t = 350 \text{ A} \cdot \text{hr} = 350 \frac{\text{C}}{\text{s}} \cdot \text{hr} \cdot 3600 \frac{\text{s}}{\text{hr}} = 1.26 \text{ MC.}$$

---

## Problem 1.6

What determines:

- The current through an ideal voltage source?
- The voltage across an ideal current source?

**Solution:****Known quantities:**

Resistance of external circuit.

**Find:**

Current supplied by an ideal voltage source

Voltage supplied by an ideal current source.

**Assumptions:**

Ideal voltage and current sources.

**Analysis:**

a) An ideal voltage source produces a constant voltage at or below its rated current. Current is determined by the power required by the external circuit (modeled as R).

$$I = \frac{V_s}{R} \quad P = V_s \cdot I$$

b) An ideal current source produces a constant current at or below its rated voltage. Voltage is determined by the power demanded by the external circuit (modeled as R).

$$V = I_s \cdot R \quad P = V \cdot I_s$$

A real source will overheat and, perhaps, burn up if its rated power is exceeded.

**Problem 1.7**

An automotive battery is rated at 120 A-h. This means that under certain test conditions it can output 1 A at 12 V for 120 h (under other test conditions, the battery may have other ratings).

a. How much total energy is stored in the battery?

b. If the headlights are left on overnight (8 h), how much energy will still be stored in the battery in the morning? (Assume a 150-W total power rating for both headlights together.)

**Solution:****Known quantities:**

Rated discharge current of the battery; rated voltage of the battery; rated discharge time of the battery.

**Find:**

Energy stored in the battery when fully recharging

Energy stored in the battery after discharging

**Analysis:**

$$\text{Energy} = \text{Power} \times \text{time} = (1A)(12V)(120\text{hr}) \left( \frac{60 \text{ min}}{\text{hr}} \right) \left( \frac{60 \text{ sec}}{\text{min}} \right)$$

a)

$$w = 5.184 \times 10^6 \text{ J}$$

b) Assume that 150 W is the combined power rating of both lights; then,

$$w_{\text{used}} = (150W)(8\text{hrs}) \left( \frac{3600 \text{ sec}}{\text{hr}} \right) = 4.32 \times 10^6 \text{ J}$$

$$w_{\text{stored}} = w - w_{\text{used}} = 864 \times 10^3 \text{ J}$$

### Problem 1.8

A car battery kept in storage in the basement needs recharging. If the voltage and the current provided by the charger during a charge cycle are shown in Figure P1.8,

- Find the total charge transferred to the battery.
- Find the total energy transferred to the battery.

#### Solution:

#### Known quantities:

Recharging current and recharging voltage

#### Find:

Total transferred charge  
Total transferred energy

#### Analysis:

a)

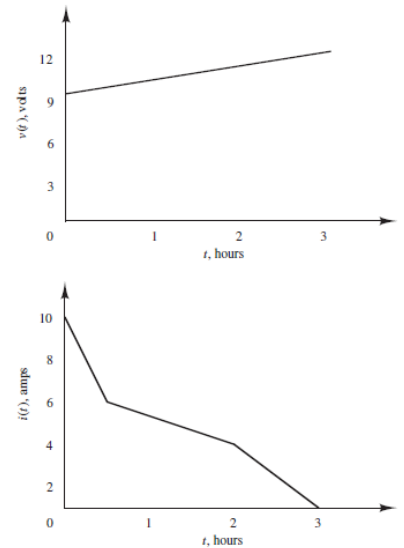

$Q = \text{area under the current - time curve} = \int I dt$

$$= \frac{1}{2} (4)(30)(60) + 6(30)(60) + \frac{1}{2} (2)(90)(60) + 4(90)(60) + \frac{1}{2} (4)(60)(60) = 48,600 \text{ C}$$

$$\boxed{Q = 48,600 \text{ C}}$$

b)  $\frac{dw}{dt} = p$  so  $w = \int p dt = \int v i dt$

$$v = 9 + \frac{3}{10800} t \quad \text{V, } 0 \leq t \leq 10800 \text{ s}$$

$$i_1 = 10 - \frac{4}{1800} t \quad \text{A, } 0 \leq t \leq 1800 \text{ s}$$

$$i_2 = 6 - \frac{2}{5400} t \quad \text{A, } 1800 \leq t \leq 7200 \text{ s}$$

$$i_3 = 12 - \frac{4}{3600} t \quad \text{A, } 7200 \leq t \leq 10800 \text{ s}$$

where  $i = i_1 + i_2 + i_3$

Therefore,

$$\begin{aligned}
w &= \int_0^{1800} v_1 i_1 dt + \int_{1800}^{7200} v_2 i_2 dt + \int_{7200}^{10800} v_3 i_3 dt \\
&= \left( 90t + \frac{t^2}{720} - \frac{t^2}{100} - \frac{t^3}{4.86 \times 10^6} \right) \Bigg|_0^{1800} \\
&+ \left( 60t + \frac{t^2}{1080} - \frac{t^2}{600} - \frac{t^3}{29.16 \times 10^6} \right) \Bigg|_{1800}^{7200} \\
&+ \left( 108t + \frac{t^2}{600} - \frac{t^2}{200} - \frac{t^3}{9.72 \times 10^6} \right) \Bigg|_{7200}^{10800} \\
&= 132.9 \times 10^3 + 380.8 \times 10^3 - 105.4 \times 10^3 + 648 \times 10^3 - 566.4 \times 10^3 \\
&\boxed{\text{Energy} = 489.9 \text{ kJ}}
\end{aligned}$$

---

### Problem 1.9

Suppose the current through a wire is given by the curve shown in Figure P1.9.

- Find the amount of charge,  $q$ , that flows through the wire between  $t_1 = 0$  and  $t_2 = 1$  s.
- Repeat part a for  $t_2 = 2, 3, 4, 5, 6, 7, 8, 9,$  and  $10$  s.
- Sketch  $q(t)$  for  $0 \leq t \leq 10$  s.

**Solution:**

**Known quantities:**

Current-time curve

**Find:**

Amount of charge during 1<sup>st</sup> second

Amount of charge for 2 to 10 seconds

Sketch charge-time curve

**Analysis:**

$$a) \quad i = \frac{4 \times 10^{-3} t}{1}$$

$$Q_1 = \int_0^1 i dt = \int_0^1 4 \times 10^{-3} t dt = 4 \times 10^{-3} \frac{t^2}{2} \Bigg|_0^1 = 2 \times 10^{-3} \frac{\text{amp}}{\text{sec}} = 2 \times 10^{-3} \text{ Coulombs}$$

b) The charge transferred from  $t=1$  to  $t=2$  is the same as from  $t=0$  to  $t=1$ .

$$Q_2 = 4 \times 10^{-3} \text{ Coulombs}$$

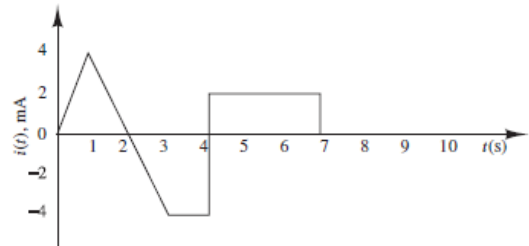

The charge transferred from  $t = 2$  to  $t = 3$  is the same in magnitude and opposite in direction to that from  $t = 1$  to  $t = 2$ .  $Q_3 = 2 \times 10^{-3}$  Coulombs

$$t = 4$$

$$Q_4 = 2 \times 10^{-3} - \int_3^4 4 \times 10^{-3} dt = 2 \times 10^{-3} - 4 \times 10^{-3} = -2 \times 10^{-3} \text{ Coulombs}$$

$$t = 5, 6, 7$$

$$Q_5 = -2 \times 10^{-3} + \int_4^5 2 \times 10^{-3} dt = 0$$

$$Q_6 = 0 + \int_5^6 2 \times 10^{-3} dt = 2 \times 10^{-3} \text{ Coulombs}$$

$$Q_7 = 2 \times 10^{-3} + \int_6^7 2 \times 10^{-3} dt = 4 \times 10^{-3} \text{ Coulombs}$$

$$t = 8, 9, 10s$$

$$Q = 4 \times 10^{-3} \text{ Coulombs}$$

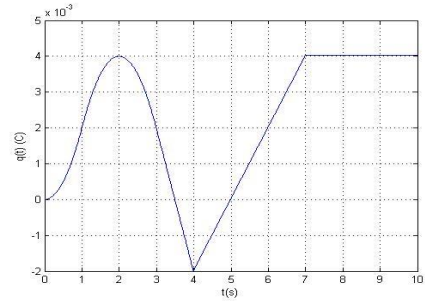

## Problem 1.10

The charge cycle shown in Figure P2.10 is an example of a two-rate charge. The current is held constant at 70 mA for 1 h. Then it is switched to 60 mA for the next 1 h. Find:

a. The total charge transferred to the battery.

b. The total energy transferred to the battery.

Hint: Recall that energy  $w$  is the integral of power, or  $P = dw/dt$ . Let:

$$v_1 = 5 + e^{t/5194.8} \text{ V}$$

$$v_2 = \left(6 - \frac{4}{e^1 - 1}\right) + \frac{4}{e^2 - e^1} * e^t \text{ V}$$

### Solution:

#### Known quantities:

See Figure P1.10

#### Find:

- The total charge transferred to the battery.
- The energy transferred to the battery.

#### Analysis:

Current is equal to  $\frac{\text{Coulombs}}{\text{Second}}$ , therefore given the current and a duration of that current, the transferred charge can be calculated by the following equation:

$$A \cdot t = C$$

The two durations should be calculated independently and then added together.

$$0.070A \cdot 3600s = 252C$$

$$0.060A \cdot 3600s = 216C$$

$$648C + 216C = \mathbf{468C}$$

$P = V \cdot I$ , therefore, an equation for power can be found by multiplying the two graphs together.

First separate the voltage graph into three equations:

$$0 \text{ h} \rightarrow 1 \text{ h} : V = 5 + e^{t/5194.8} \text{ V}$$

$$1 \text{ h} \rightarrow 2 \text{ h} : V = \left(6 - \frac{4}{e^1 - 1}\right) + \frac{4}{e^2 - e^1} * e^t \text{ V}$$

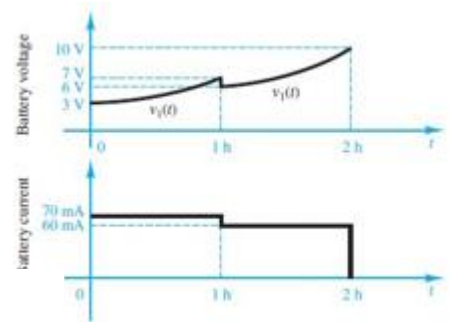

Next, multiply the first equation by 0.07A and the second by 0.06A.

$$0 \text{ h} \rightarrow 1 \text{ h} : P = 0.35 + 0.07e^{t/5194.8}$$

$$1 \text{ h} \rightarrow 2 \text{ h} : P = 0.06 \left( 6 - \frac{4}{e^{1h}-1} \right) + 0.06 \frac{4}{e^{2h}-e^{1h}} * e^{tV}$$

Finally, since Energy is equal to the integral of power, take the integral of each of the equations for their specified times and add them together.

$$0 \text{ h} \rightarrow 1 \text{ h} : E = \left[ 0.35t + 363.64e^{t/5194.8} \right] \Big|_0^{3600} = 1623.53 \text{ J}$$

$$1 \text{ h} \rightarrow 2 \text{ h} : E = \left[ 0.36t + 2.88 * 10^{-3128} * 2.72^t \right] \Big|_{3600}^{7200} = 1296.24 \text{ J}$$

$$E_{Total} = 2919.77 \text{ J}$$

## Problem 1.11

The charging scheme used in Figure P1.11 is an example of a constant-current charge cycle. The charger voltage is controlled such that the current into the battery is held constant at 40 mA, as shown in Figure P1.11. The battery is charged for 6 h. Find:

- The total charge delivered to the battery.
  - The energy transferred to the battery during the charging cycle.
- Hint: Recall that the energy,  $w$ , is the integral of power, or  $P = dw/dt$ .

### Solution:

#### Known quantities:

Current-time curve and voltage-time curve of battery recharging

#### Find:

Total transferred charge  
Total transferred energy

#### Analysis:

a)  $40 \text{ mA} = 0.04 \text{ A}$

$$Q = \text{area under the current - time curve} = \int I dt = (0.04)(6)(3600) = 864 \text{ C}$$

$$Q = 864 \text{ C}$$

b)  $\frac{dw}{dt} = P$  so

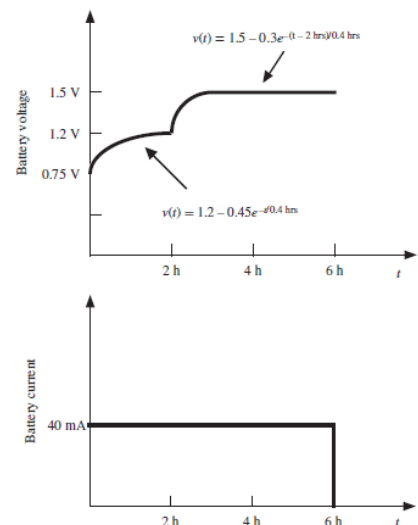

$$\begin{aligned}
 w &= \int_0^2 P dt = \int_0^2 v i dt = (3600) \int_0^2 v i dt + (3600) \int_2^4 v i dt \\
 &= (3600) \int_0^2 (1.2 - 0.45e^{-t/0.4})(0.04) dt + (3600) \int_2^4 (1.5 - 0.3e^{-(t-2)/0.4})(0.04) dt \\
 &= 1,167 J \\
 \boxed{\text{Energy} = 1,167 J}
 \end{aligned}$$

### Problem 1.12

The charging scheme used in Figure P1.12 is called a tapered-current charge cycle. The current starts at the highest level and then decreases with time for the entire charge cycle, as shown. The battery is charged for 12 h. Find:

- The total charge delivered to the battery.
  - The energy transferred to the battery during the charging cycle.
- Hint: Recall that the energy,  $w$ , is the integral of power, or  $P = dw/dt$ .

#### Solution:

#### Known quantities:

Current-time curve and voltage-time curve of battery recharging

#### Find:

Total transferred charge  
Total transferred energy

#### Analysis:

$$Q = \text{area under the current - time curve} = \int I dt = (3600) \int_0^{12} e^{-5t/12} dt = 8,564 \text{ C}$$

a)

$$\boxed{Q = 8,564 \text{ C}}$$

b)  $\frac{dw}{dt} = P$  so

$$w = \int_0^2 P dt = \int_0^2 v i dt = (3600) \int_0^2 (12 - 3e^{-5t/12})(e^{-5t/12}) dt$$

$$= 8,986 J$$

$$\boxed{\text{Energy} = 8,986 J}$$

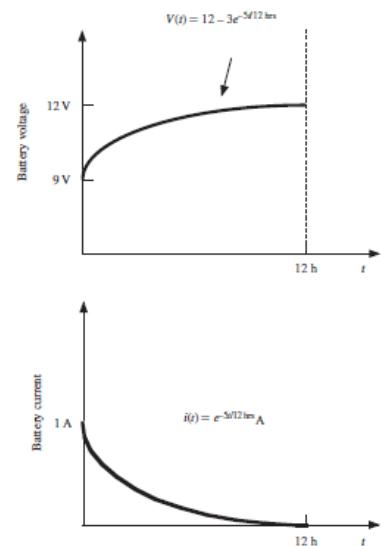

### Problem 1.13

Use KCL to determine the unknown currents in Figure P1.13.

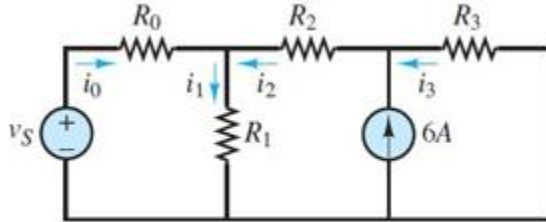

**Solution:**

**Known quantities:**

$$i_0 = 2 \text{ A}, \quad i_2 = -7 \text{ A}$$

**Find:**

$$i_1$$

$$i_3$$

**Analysis:**

- a) Use KCL at the node between  $R_0$ ,  $R_1$ , and  $R_2$ .

$$i_0 - i_1 + i_2 = 0$$

$$i_1 = i_0 + i_2$$

$$i_1 = -5 \text{ A}$$

- b) Use KCL at the node between  $R_2$ ,  $R_3$ , and the current source.

$$6 \text{ A} + i_3 - i_2 = 0$$

$$i_3 = i_2 - 6 \text{ A}$$

$$i_3 = -13 \text{ A}$$

### Problem 1.14

Use KCL to find the currents  $i_1$  and  $i_2$  in Figure P1.14.

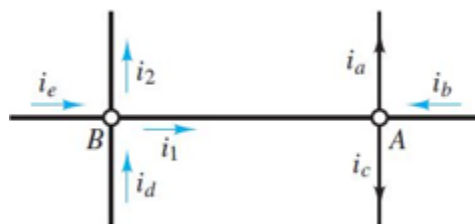

**Solution:**

**Known quantities:**

$$i_a = 3 \text{ A}, \quad i_b = -2 \text{ A}, \quad i_c = 1 \text{ A}, \quad i_d = 6 \text{ A}, \quad i_e = -4 \text{ A}$$

**Find:**

$$i_1$$

$$i_2$$

**Analysis:**

a) Use KCL at Node A.

$$i_1 + i_b - i_a - i_c = 0$$

$$i_1 = i_a - i_b + i_c$$

$$i_1 = 6 \text{ A}$$

b) Use KCL at Node B.

$$i_e + i_d - i_1 - i_2 = 0$$

$$i_2 = i_e + i_d - i_1$$

$$i_2 = -4 \text{ A}$$

**Problem 1.15**

Use KCL to find the current  $i_1$ ,  $i_2$ , and  $i_3$  in the circuit of Figure P1.15.

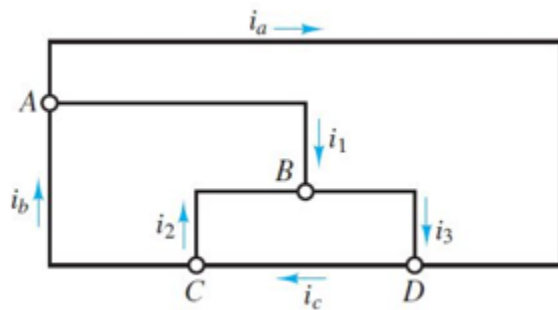

**Solution:**

**Known quantities:**

$$i_a = 2 \text{ mA}, \quad i_b = 7 \text{ mA}, \quad i_c = 4 \text{ mA}$$

**Find:**

$$i_1$$

$$i_2$$

$$i_3$$

### Analysis:

- a) Use KCL at Node A.

$$i_b - i_a - i_1 = 0$$

$$i_1 = i_b - i_a$$

$$i_1 = 5\text{mA}$$

- b) Use KCL at Node C.

$$i_c - i_2 - i_b = 0$$

$$i_2 = i_c - i_b$$

$$i_2 = -3\text{mA}$$

- c) Use KCL at Node D.

$$i_3 + i_a - i_c = 0$$

$$i_3 = i_c - i_a$$

$$i_3 = 2\text{mA}$$

### Problem 1.16

Use KVL to find the voltages  $v_1, v_2,$  and  $v_3$  in Figure P1.16.

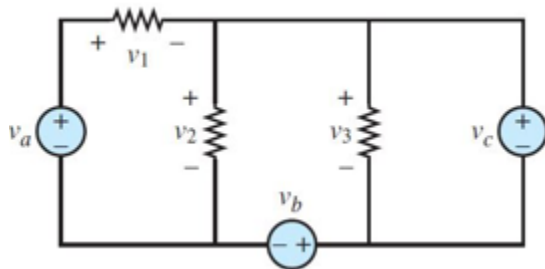

### Solution:

#### Known quantities:

$$V_a = 2\text{ V}, \quad V_b = 4\text{ V}, \quad V_c = 5\text{ V}$$

#### Find:

$$V_1$$

$$V_2$$

$$V_3$$

### Analysis:

- a) Use KVL at the third loop.

$$V_3 - V_c = 0$$

$$V_3 = V_c$$

$$V_3 = 5\text{V}$$

- b) Use KVL at the second loop.

$$V_2 - V_3 - V_b = 0$$

$$V_2 = V_3 + V_b$$

$$1.15$$

$$V_2 = 9V$$

c) Use KCL at the first loop.

$$\begin{aligned}V_a - V_1 - V_2 &= 0 \\V_1 &= V_a - V_2 \\V_1 &= -7V\end{aligned}$$

---

## Problem 1.17

Use KCL to determine the current  $i_1$ ,  $i_2$ ,  $i_3$ , and  $i_4$  in the circuit of Figure P1.17.

### Solution:

#### Known quantities:

$$i_a = -2 \text{ A}, \quad i_b = 6 \text{ A}, \quad i_c = 1 \text{ A}, \quad i_d = -4 \text{ A}$$

#### Find:

$i_1$   
 $i_2$   
 $i_3$   
 $i_4$

#### Analysis:

a) Use KCL at Node A.

$$\begin{aligned}i_1 - i_a - i_c &= 0 \\i_1 &= i_a + i_c \\i_1 &= -1A\end{aligned}$$

b) Use KCL at Node B.

$$\begin{aligned}i_2 - i_1 - i_b &= 0 \\i_2 &= i_1 + i_b \\i_2 &= 5A\end{aligned}$$

c) Use KCL at Node C.

$$\begin{aligned}i_3 - i_2 - i_d &= 0 \\i_3 &= i_2 + i_d \\i_3 &= 1A\end{aligned}$$

d) Use KCL at Node D.

$$\begin{aligned}i_c + i_4 - i_3 &= 0 \\i_4 &= i_3 - i_c \\i_4 &= 0A\end{aligned}$$

---

## Section 1.4 Power and the Passive Sign Convention

### Problem 1.18

In the circuits of Figure P1.18, the directions of current and polarities of voltage have already been defined. Find the actual values of the indicated currents and voltages.

**Solution:**

**Known quantities:**

Circuit shown in Figure P1.18.

**Find:**

Voltages and currents in every figure.

**Analysis:**

(a) Using  $I = \frac{15}{30+20}$  (clockwise current) :  $I_1 = -0.3A; I_2 = 0.3A; V_1 = 6V$

(b) The voltage across the  $20\ \Omega$  resistor is  $\frac{20}{4} = 5V$ ; since the current flows from top to bottom, the polarity of this voltage is positive on top. Then it follows that  $V_1 = 5V$  and  $I_2 = \frac{5}{30} = -0.167A$

(the negative sign follows from the direction of  $I_2$  in the drawing).

(c) Since  $-0.5A$  pointing upward is the same current as  $0.5A$  pointing downward, the voltage across the  $30\ \Omega$  resistor is

$$V_{30\Omega} = 15V \quad (\text{positive on top}); \text{ and } I_2 = \frac{15}{20} = 0.75A,$$

since  $V_{30\Omega}$  is also the voltage across the  $20\ \Omega$  resistor. Finally,

$$I_1 = -(I_2 + 0.5) = -1.25A, \text{ and } V_1 = -30 I_1 + 15 = 52.5V$$

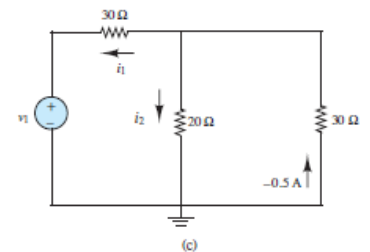
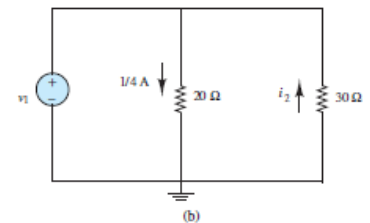
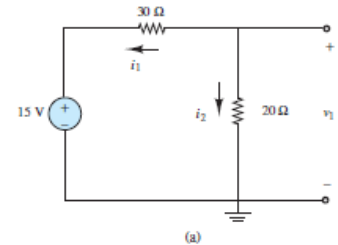

## Problem 1.19

Find the power delivered by each source in Figure P1.19.

**Solution:**

**Known quantities:**

Circuit shown in Figure P1.19.

- Power delivered by the 3A Current Source
- Power delivered by the -9V Voltage Source

**Analysis:**

- Follow the counterclockwise current:

$$P = (+3A) \cdot (+10V)$$

$$P = +30W \text{ supplied}$$

- Follow the counterclockwise current:

$$P = (+5A) \cdot (-9V)$$

$$P = -45W \text{ supplied}$$

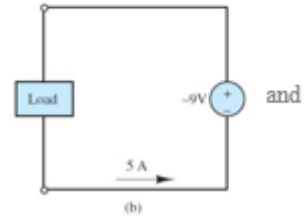
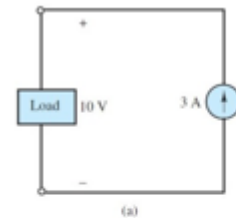

## Problem 1.20

Determine whether each element in Figure P2.20 is supplying or dissipating power, and how much.

**Solution:**

**Known quantities:**

Circuit shown in Figure P1.20.

**Find:**

Determine power dissipated or supplied for each power source.

**Analysis:**

Element A:

$$P = -vi = -(-12V)(25A) = 300W \text{ (dissipating)}$$

Element B:

$$P = vi = (15V)(25A) = 375W \text{ (dissipating)}$$

Element C:

$$P = vi = (27V)(25A) = 675W \text{ (supplying)}$$

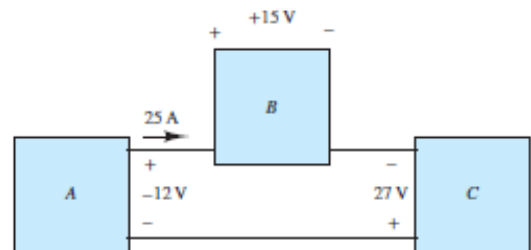

## Problem 1.21

In the circuit of Figure P1.21, find the power absorbed by  $R_4$  and the power delivered by the current source.

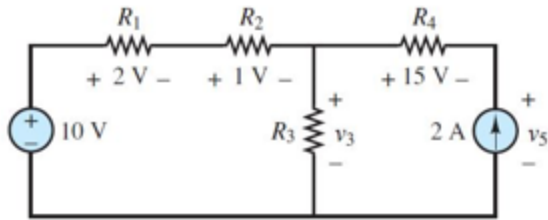

**Solution:**

**Known quantities:**

Circuit shown in Figure P1.21.

**Find:**

- a) Power absorbed by  $R_4$
- b) Power delivered by the current source

**Analysis:**

- a) Follow the counterclockwise current in the rightmost loop:

$$P = (2A) \cdot (-15V)$$

$$P = -30W \text{ absorbed}$$

$$P = +30W \text{ supplied}$$

- b) Use KVL at the leftmost loop to find  $V_3$ :

$$10V - 2V - 1V - V_3 = 0$$

$$V_3 = 7V$$

Use KVL at the rightmost loop to find  $V_5$ :

$$7V - 15V - V_5 = 0$$

$$V_5 = -8V$$

The current source has a -8V drop across it. Use this to calculate the power dissipated using the proper sign convention.

$$(+2A) \cdot (-8V) = -16W \text{ supplied}$$

**Problem 1.22**

For the circuit shown in Figure P1.22:

- a. Determine whether each component is absorbing or delivering power.
- b. Is conservation of power satisfied? Explain your answer.

**Solution:**

**Known quantities:**

Circuit shown in Figure P1.22.

**Find:**

Determine power absorbed or power delivered  
 Testify power conservation

**Analysis:**

By KCL, the current through element B is 5A, to the right.

By KVL,  $-v_a - 3 + 10 + 5 = 0$ .

Therefore, the voltage across element A is

$v_a = 12V$  (positive at the top).

A supplies  $(12V)(5A) = 60W$

B supplies  $(3V)(5A) = 15W$

C absorbs  $(5V)(5A) = 25W$

D absorbs  $(10V)(3A) = 30W$

E absorbs  $(10V)(2A) = 20W$

Total power supplied =  $60W + 15W = 75W$

Total power absorbed =  $25W + 30W + 20W = 75W$

Tot. power supplied = Tot. power absorbed

$\therefore$  conservation of power is satisfied.

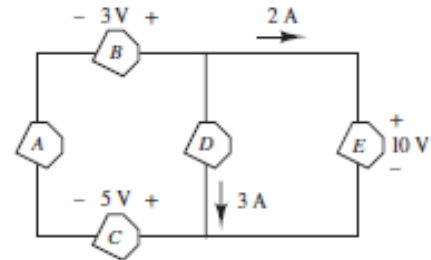
**Problem 1.23**

For the circuit shown in Figure P1.23, determine the power absorbed by the  $5\ \Omega$  resistor.

**Solution:****Known quantities:**

Circuit shown in Figure P1.23.

**Find:**

Power absorbed by the  $5\ \Omega$  resistance.

**Analysis:**

The current flowing clockwise in the series circuit is  $i = \frac{20V}{20\ \Omega} = 1A$

The voltage across the  $5\ \Omega$  resistor, positive on the left, is  $v_{5\ \Omega} = (1A)(5\ \Omega) = 5V$

Therefore,  $P_{5\ \Omega} = (5V)(1A) = 5W$

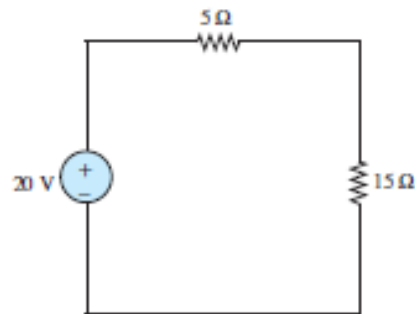
**Problem 1.24**

For the circuit shown in Figure P1.24, determine which components are supplying power and which are dissipating power. Also determine the amount of power dissipated and supplied.

**Solution:**

**Known quantities:**

Circuit shown in Figure P1.24.

**Find:**

Determine power absorbed or power delivered and corresponding amount.

**Analysis:**

If current direction is out of power source, then power source is supplying, otherwise it is absorbing.

A supplies  $(100V)(4A) = 400\text{ W}$

B absorbs  $(10V)(4A) = 40\text{ W}$

C supplies  $(100V)(1A) = 100\text{ W}$

D supplies  $(-10V)(1A) = -10\text{ W}$ , i.e absorbs  $10\text{ W}$

E absorbs  $(90V)(5A) = 450\text{ W}$

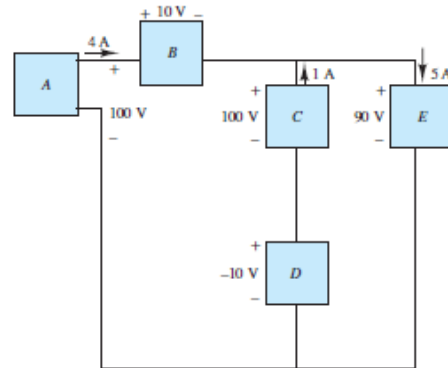

**Problem 1.25**

For the circuit shown in Figure P1.25.determine which components are supplying power and which are dissipating power. Also determine the amount of power dissipated and supplied.

**Solution:**

**Known quantities:**

Circuit shown in Figure P1.25.

**Find:**

Determine power absorbed or power delivered and corresponding amount.

**Analysis:**

If current direction is out of power source, then power source is supplying, otherwise it is absorbing.

A absorbs  $(5V)(4A) = 20\text{ W}$

B supplies  $(2V)(6A) = 12\text{ W}$

D supplies  $(3V)(4A) = 12\text{ W}$

Since conservation of power is satisfied, Tot. power supplied = Tot. power absorbed

Total power supplied =  $12\text{ W} + 12\text{ W} = 24\text{ W}$

$\therefore$  C absorbs  $24\text{ W} - 20\text{ W} = 4\text{ W}$

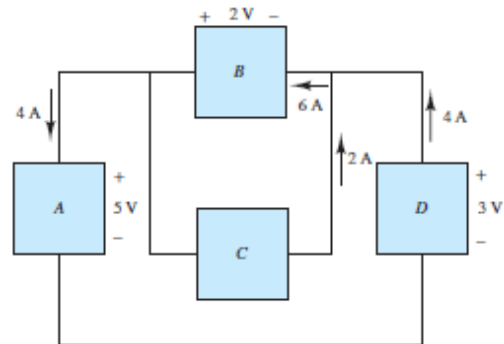

**Problem 1.26**

If an electric heater requires 23 A at 110 V, determine

- a. The power it dissipates as heat or other losses.
- b. The energy dissipated by the heater in a 24-hperiod.
- c. The cost of the energy if the power company charges at the rate 6 cents/kWh.

**Solution:****Known quantities:**

Current absorbed by the heater; voltage at which the current is supplied; cost of the energy.

**Find:**

Power consumption

Energy dissipated in 24 hr.

Cost of the Energy

**Assumptions:**

The heater works for 24 hours continuously.

**Analysis:**

$$\text{a) } P = VI = 110 \text{ V} (23 \text{ A}) = 2.53 \times 10^3 \frac{\text{J}}{\text{A s}} = 2.53 \text{ kW}$$

$$\text{b) } W = Pt = 2.53 \times 10^3 \frac{\text{J}}{\text{s}} \times 24 \text{ hr} \times 3600 \frac{\text{s}}{\text{hr}} = 218.6 \text{ MJ}$$

$$\text{c) } \text{Cost} = (\text{Rate}) \times W = 6 \frac{\text{cents}}{\text{kW-hr}} (2.53 \text{ kW})(24 \text{ hr}) = 364.3 \text{ cents} = \$3.64$$

## Sections 1.5-1.6: *i-v* Characteristics and Sources; Resistance and Ohm's Law

**Problem 1.27**

In the circuit shown in Figure P1.27, determine the terminal voltage  $v_T$  of the source, the power absorbed by  $R_o = R_L$  and the efficiency of the circuit. Efficiency is defined as the ratio of load power to source power.

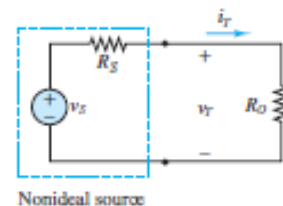
**Solution:****Known quantities:**

Circuit shown in Figure P1.27 with voltage source,  $V_s = 12\text{V}$ ; internal resistance of the source,  $R_s = 5\text{k}\Omega$ ; and resistance of the load,  $R_L = 7\text{k}\Omega$ .

**Find:**

The terminal voltage of the source; the power supplied to the circuit, the efficiency of the circuit.

**Assumptions:**

Assume that the only loss is due to the internal resistance of the source.

**Analysis:**

$$KVL: -V_S + I_T R_S + V_T = 0 \quad OL: V_T = I_T R_L \quad \therefore I_T = \frac{V_T}{R_L}$$

$$-V_S + \frac{V_T}{R_L} R_S + V_T = 0$$

$$V_T = \frac{V_S}{1 + \frac{R_S}{R_L}} = \frac{12 V}{1 + \frac{5 k\Omega}{7 k\Omega}} = 7 V \quad \text{or} \quad VD: V_T = \frac{V_S R_L}{R_S + R_L} = \frac{12 V \cdot 7 k\Omega}{5 k\Omega + 7 k\Omega} = 7 V.$$

$$P_L = \frac{V_R^2}{R_L} = \frac{V_T^2}{R_L} = \frac{(7 V)^2}{7 \times 10^3 \frac{V}{A}} = 7 \text{ mW}$$

$$\eta = \frac{P_{out}}{P_{in}} = \frac{P_{R_L}}{P_{R_S} + P_{R_L}} = \frac{I_T^2 R_L}{I_T^2 R_S + I_T^2 R_L} = \frac{7 k\Omega}{5 k\Omega + 7 k\Omega} = 0.5833 \quad \text{or} \quad 58.33\%$$

**Problem 1.28**

A 24-V automotive battery is connected to two headlights that are in parallel, similar to that shown in Figure 1.11. Each headlight is intended to be a 75-W load; however, one 100-W headlight is mistakenly installed. What is the resistance of each headlight? What is the total resistance seen by the battery?

**Solution:****Known quantities:**

Headlights connected in parallel to a 24-V automotive battery; power absorbed by each headlight.

**Find:**

Resistance of each headlight; total resistance seen by the battery.

**Analysis:**

Headlight no. 1:

$$P = v \times i = 100 \text{ W} = \frac{v^2}{R} \quad \text{or}$$

$$R = \frac{v^2}{100} = \frac{576}{100} = 5.76 \Omega$$

Headlight no. 2:

$$P = v \times i = 75 \text{ W} = \frac{v^2}{R} \quad \text{or}$$

$$R = \frac{v^2}{75} = \frac{576}{75} = 7.68 \Omega$$

The total resistance is given by the parallel combination:

$$\frac{1}{R_{TOTAL}} = \frac{1}{5.76 \Omega} + \frac{1}{7.68 \Omega} \quad \text{or} \quad R_{TOTAL} = 3.29 \Omega$$

## Problem 1.29

What is the equivalent resistance seen by the battery of Problem 1.28 if two 15-W taillights are added (in parallel) to the two 75-W (each) headlights?

### Solution:

#### Known quantities:

Headlights and 24-V automotive battery of problem 2.13 with 2 15-W taillights added in parallel; power absorbed by each headlight; power absorbed by each taillight.

#### Find:

Equivalent resistance seen by the battery.

#### Analysis:

The resistance corresponding to a 75-W headlight is:

$$R_{75W} = \frac{v^2}{75} = \frac{576}{75} = 7.68 \Omega$$

For each 15-W tail light we compute the resistance:

$$R_{15W} = \frac{v^2}{15} = \frac{576}{15} = 38.4 \Omega$$

Therefore, the total resistance is computed as:

$$\frac{1}{R_{TOTAL}} = \frac{1}{7.68\Omega} + \frac{1}{7.68\Omega} + \frac{1}{38.4\Omega} + \frac{1}{38.4\Omega} \text{ or } R_{TOTAL} = 3.2 \Omega$$

## Problem 1.30

For the circuit shown in Figure P1.30, determine the power absorbed by the variable resistor R, ranging from 0 to 30  $\Omega$ . Plot the power absorption as a function of R. Assume that  $v_s = 15 \text{ V}$ ,  $R_s = 10 \Omega$ .

### Solution:

#### Known quantities:

$v_s = 15\text{V}$ ,  $R_s = 10 \text{ Ohms}$ , and the circuit in Figure P1.30.

#### Find:

R

#### Analysis:

Use ohms law to find an equation for P as a function of R:

$$P_R = V_R * I_R$$

The voltage across R is equal to the source voltage minus the voltage across  $R_s$ :

$$V_R = 15\text{V} - V_{R_s}$$

$V_{R_s}$  is determined by the current through the loop which can be found by adding the resistors in series:

$$I_R = \frac{15\text{V}}{(R_s + R)}$$

$$V_{R_s} = 10\Omega * I_R$$

Simplify:

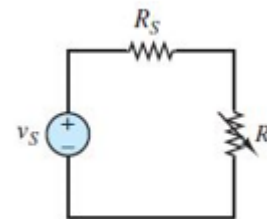

$$P_R = \left[ 15V - \left( 10\Omega * \frac{15V}{10\Omega + R} \right) \right] * \left[ \frac{15V}{10\Omega + R} \right]$$

Plot:

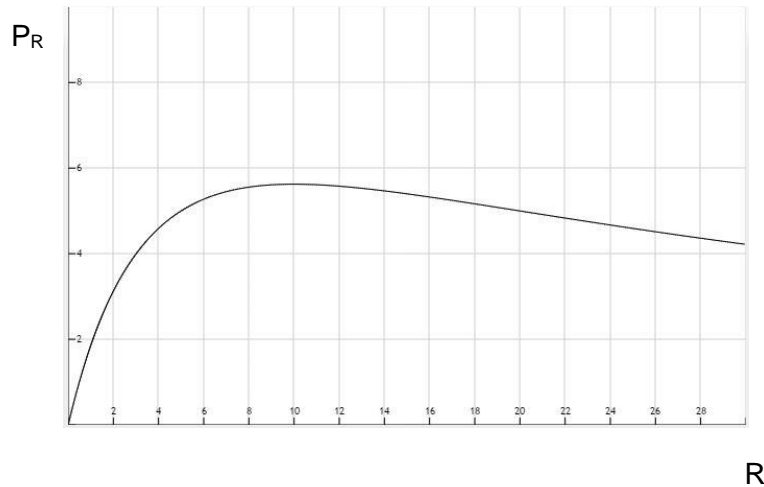

### Problem 1.31

Refer to Figure P1.27 and assume that  $v_S = 15\text{ V}$  and  $R_S = 100\ \Omega$ . For  $i_T = 0, 10, 20, 30, 80,$  and  $100\text{ mA}$ :

- Find the total power supplied by the ideal source.
- Find the power dissipated within the non-ideal source.
- How much power is supplied to the load resistor?
- Plot the terminal voltage  $v_T$  and power supplied to the load resistor as a function of terminal current  $i_T$ .

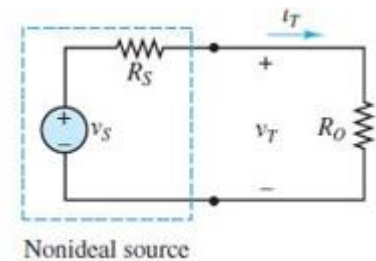

**Solution:**

**Known quantities:**

$v_S=15\text{V}$ ,  $R_S=100\text{ Ohms}$ ,  $i_T= 0, 10, 20, 30, 80, 100\text{ mA}$ .  
The circuit in Figure P1.27.

**Find:**

- The total power supplied by the ideal source
- The power dissipated within the non-ideal source
- How much power is supplied to the load resistor
- Plot  $v_T$  and power supplied to  $R_0$  as a function of  $i_T$ .

**Analysis:**

- The power supplied by the ideal source is equal to the current through the loop times the  $15\text{V}$  of the supply. From current lowest to highest the power supplied would be:  
 $0\text{W}$     $0.15\text{W}$     $0.3\text{W}$     $0.45\text{W}$     $1.2\text{W}$     $1.5\text{W}$
- The power dissipated within the non-ideal source is the power dissipated by  $R_S$  which can be found using  $P=i^2*r$ . From current lowest to highest the power dissipated would be:  
 $0\text{W}$     $0.01\text{W}$     $0.04\text{W}$     $0.09\text{W}$     $0.64\text{W}$     $1\text{W}$
- The power supplied to the load resistor is equal to the total power supplied minus the power dissipated by the non-ideal source. From current lowest to highest the power supplied would be:

- 0W    0.14W    0.26W    0.36W    0.56W    0.5W
- d) For the  $v_T$  plot Ohm's Law can be used to find the voltage drop across  $R_s$  which is equal to  $V_T$ . For the power plot, the data from part c can be used directly.

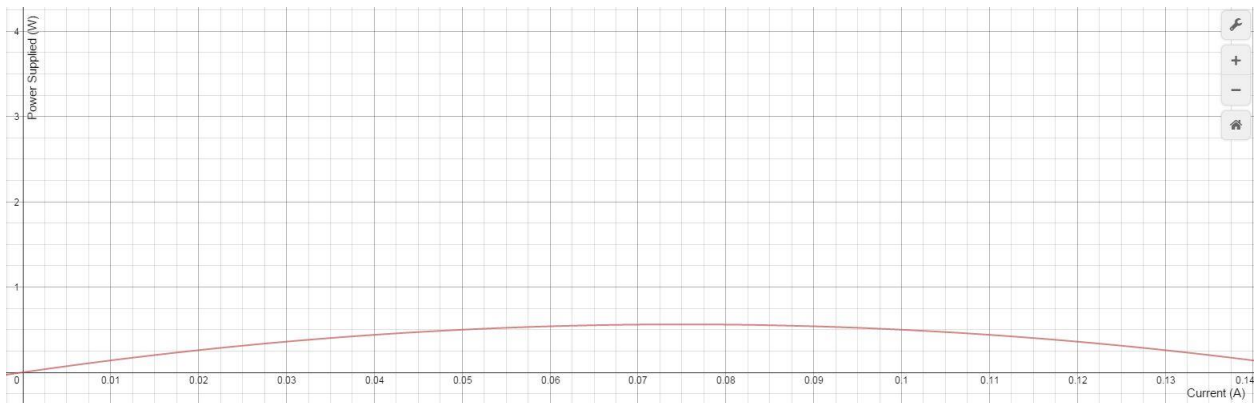
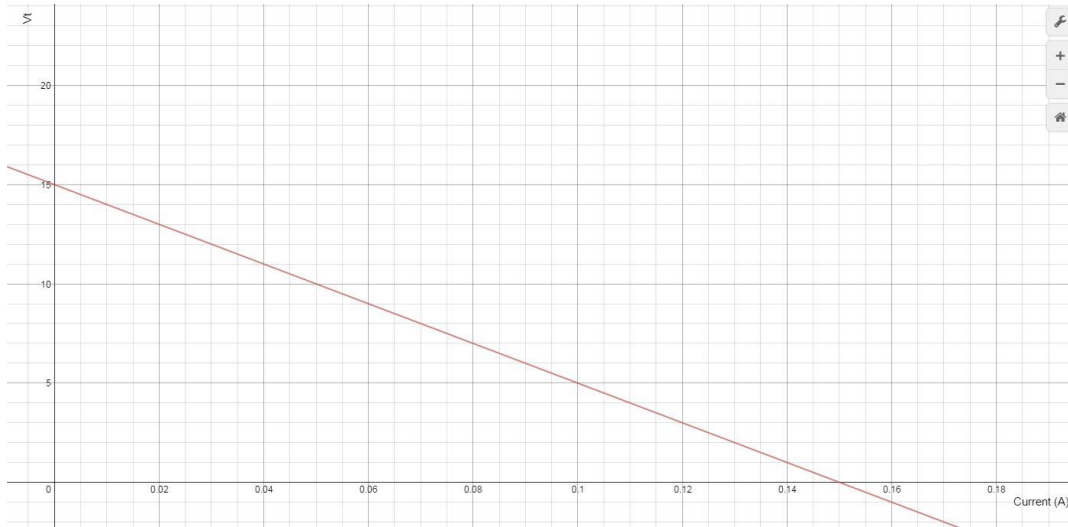

### Problem 1.32

In the circuit in Figure P1.32, assume  $v_2 = v_s/6$  and the power delivered by the source is 150 mW. Also assume that  $R_1 = 8 \text{ k}\Omega$ ,  $R_2 = 10 \text{ k}\Omega$ ,  $R_3 = 12 \text{ k}\Omega$ . Find  $R$ ,  $v_s$ ,  $v_2$ , and  $i$ .

**Solution:**

**Known quantities:**

$R_1=8k\Omega$ ,  $R_2=10k\Omega$ ,  $R_3=12k\Omega$  and the circuit in Figure P1.32.

**Find:**

$R$ ,  $v_s$ ,  $v_2$ , and  $i$ .

**Analysis:**

Use ohms law to find  $v_s$  and  $i$ :

$$v_2 = \frac{v_s}{6} = R_2 * i$$

Also:

$$v_s * i = 150mW$$

So:

$$i = \sqrt{\frac{150mW}{R_2 * 6}} = 1.6mA$$

Since we know  $i$ ,  $v_s$  can easily be found:

$$v_s * i = 150mW$$
$$v_s = 94.87V$$

$$v_2 = \frac{v_s}{6} = 15.81V$$

Use Ohm's law to find  $R_{eq}$ :

$$\frac{v_s}{i} = R_{eq} = 60k\Omega$$

Use  $R_{eq}$  to find  $R$ :

$$R_{eq} = R_1 + R + R_2 + R_3$$
$$R = R_{eq} - (R_1 + R_2 + R_3) = 30k\Omega$$

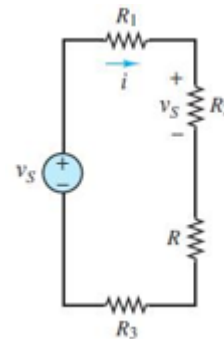

---

### Problem 1.33

A GE SoftWhite Longlife lightbulb is rated as follows:

$P_R$  = rated power = 60 W

$P_{OR}$  = rated optical power = 820 lumens (lm) (average)

1 lumen = 1/680W

Operating life = 1,500 h (average)

$V_R$  = rated operating voltage = 115 V

The resistance of the filament of the bulb, measured with a standard multimeter, is 16.7  $\Omega$ .

When the bulb is connected into a circuit and is operating at the rated values given above, determine

- The resistance of the filament.
- The efficiency of the bulb.

**Solution:****Known quantities:**

Rated power; rated optical power; operating life; rated operating voltage; open-circuit resistance of the filament.

**Find:**

The resistance of the filament in operation  
The efficiency of the bulb.

**Analysis:**

a)

$$P = VI \quad \therefore I = \frac{P_R}{V_R} = \frac{60 \text{ VA}}{115 \text{ V}} = 521.7 \text{ mA}$$

$$R = \frac{V}{I} = \frac{V_R}{I} = \frac{115 \text{ V}}{521.7 \text{ mA}} = 220.4 \Omega$$

OL:

b)

Efficiency is defined as the ratio of the useful power dissipated by or supplied by the load to the total power supplied by the source. In this case, the useful power supplied by the load is the optical power. From any handbook containing equivalent units: 680 lumens=1 W

$$P_{o,out} = \text{Optical Power Out} = 820 \text{ lum} \frac{\text{W}}{680 \text{ lum}} = 1.206 \text{ W}$$

$$\eta = \text{efficiency} = \frac{P_{o,out}}{P_R} = \frac{1.206 \text{ W}}{60 \text{ W}} = 0.02009 = 2.009 \%$$

**Problem 1.34**

An incandescent lightbulb rated at 100 W will dissipate 100 W as heat and light when connected across a 110-V ideal voltage source. If three of these bulbs are connected in series across the same source, determine the power each bulb will dissipate.

**Solution:****Known quantities:**

Rated power; rated voltage of a light bulb.

**Find:**

The power dissipated by a series of three light bulbs connected to the nominal voltage.

**Assumptions:**

The resistance of each bulb doesn't vary when connected in series.

**Analysis:**

When connected in series, the voltage of the source will divide equally across the three bulbs. The across each bulb will be 1/3 what it was when the bulbs were connected individually across the source. Power dissipated in a resistance is a function of the voltage squared, so the power dissipated in each bulb when connected in series will be 1/9 what it was when the bulbs were connected individually, or 11.11 W:

$$\text{Ohm's Law: } P = IV_B = I^2 R_B = \frac{V_B^2}{R_B} \quad V_B = V_S = 110 \text{ V} \quad R_B = \frac{V_B^2}{P} = \frac{(110 \text{ V})^2}{100 \text{ VA}} = 121 \Omega$$

Connected in series and assuming the resistance of each bulb remains the same as when connected individually:

$$\text{KVL: } -V_S + V_{B1} + V_{B2} + V_{B3} = 0 \quad \text{OL: } -V_S + IR_{B3} + IR_{B2} + IR_{B1} = 0$$

$$I = \frac{V_S}{R_{B1} + R_{B2} + R_{B3}} = \frac{110 \text{ V}}{121 + 121 + 121 \text{ V/A}} = 303 \text{ mA}$$

$$P_{B1} = I^2 R_{B1} = (303 \text{ mA})^2 (121 \text{ V/A}) = 11.11 \text{ W} = \frac{1}{9} 100 \text{ W}.$$

### Problem 1.35

An incandescent lightbulb rated at 60 W will dissipate 60 W as heat and light when connected across a 100-V ideal voltage source. A 100-W bulb will dissipate 100 W when connected across the same source. If the bulbs are connected in series across the same source, determine the power that either one of the two bulbs will dissipate.

#### Solution:

#### Known quantities:

Rated power and rated voltage of the two light bulbs.

#### Find:

The power dissipated by the series of the two light bulbs.

#### Assumptions:

The resistance of each bulb doesn't vary when connected in series.

#### Analysis:

For the two bulbs in series KVL and KCL require

$$100\text{V} = V_{100} + V_{60} \quad \text{and} \quad I_{100} = I_{60}$$

The resistance of each bulb when connected individually across a 100V source is

$$R_{100} = \frac{(100\text{V})^2}{100\text{W}} = 100\Omega \quad \text{and} \quad R_{60} = \frac{(100\text{V})^2}{60\text{W}} \cong 167\Omega$$

Assume that the resistance of each bulb is the same when operated in series as when operated alone. Then

$$V_{100} = I_{100} R_{100} = I_{60}(100) \quad \text{and} \quad V_{60} = I_{60} R_{60} = I_{60}(167)$$

Plug into the KVL equation to find

$$100\text{V} \cong I_{60}(100 + 167) \rightarrow I_{60} \cong \frac{100}{267} \text{ A} \cong I_{100}$$

The power absorbed by each bulb is

$$P_{100} = I_{100}^2 R_{100} \cong 14.0\text{W}$$

And

$$P_{60} = I_{60}^2 R_{60} \cong 23.4\text{W}$$

Notes: 1. It's strange but it's true that a 60 W bulb connected in series with a 100 W bulb will dissipate more power than the 100 W bulb. 2. If the power dissipated by the filament in a bulb decreases, the temperature at which the filament operates and therefore its resistance will decrease. This fact made the assumption about the resistance necessary.

### Problem 1.36

Refer to Figure P1.36, and assume that  $v_s = 12\text{ V}$ ,  $R_1 = 5\ \Omega$ ,  $R_2 = 3\ \Omega$ ,  $R_3 = 4\ \Omega$ , and  $R_4 = 5\ \Omega$ . Find:

- The voltage  $v_{ab}$ .
- The power dissipated in  $R_2$ .

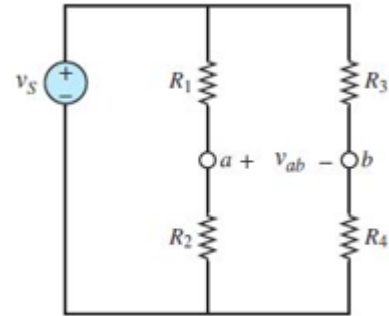

#### Solution:

#### Known quantities:

Circuit of Figure P2.36.  $R_1=5\Omega$ ,  $R_2=3\Omega$ ,  $R_3=4\Omega$ ,

$R_4=5\Omega$ ,  $v_s=12\text{V}$ .

#### Find:

$v_{ab}$  and the power dissipated in  $R_2$ .

#### Analysis:

Find the current through each resistor pair by combining them in series:

$$R_1 + R_2 = 8\ \Omega$$

$$R_3 + R_4 = 9\ \Omega$$

Since there is 12V across both of them Ohm's law is used to find the currents:

$$12\text{V} = 8\ \Omega * I_a$$

$$I_a = 1.5\text{A}$$

$$12\text{V} = 9\ \Omega * I_b$$

$$I_b = 1.33\text{A}$$

Now find the voltage drop across  $R_1$  and  $R_3$ :

$$V_a = 12\text{V} - (I_a * R_1) = 4.5\text{V}$$

$$V_b = 12\text{V} - (I_b * R_3) = 6.66\text{V}$$

$$V_{ab} = -2.17\text{V}$$

An alternate and more efficient approach is to apply voltage division to find the voltage across  $R_2$  and  $R_4$ , respectively:

$$v_2 = v_s \frac{R_2}{R_1 + R_2} = 4.5\text{V}$$

$$v_4 = v_s \frac{R_4}{R_3 + R_4} = \frac{20}{3}\text{V}$$

It is implied in the calculations that the polarities of  $v_2$  and  $v_4$  are high (+) to low (-) from above to below each resistor in the figure. Apply KVL to find:

$$v_{ab} = v_2 - v_4 = \frac{13.5}{3} - \frac{20}{3} = -\frac{6.5}{3}\text{V} \cong -2.16\text{V}$$

$P_{R_2}$  is equal to  $I_b$  times  $V_a$ :

$$P_{R_2} = v_2 i_2 = \frac{v_2^2}{R_2} = 6.75\text{W}$$

### Problem 1.37

Refer to Figure P1.37, and assume that  $V_s = 7\text{ V}$ ,  $I_s = 3\text{ A}$ ,  $R_1 = 20\ \Omega$ ,  $R_2 = 12\ \Omega$ , and  $R_3 = 10\ \Omega$ .

Find:

- The currents  $i_1$  and  $i_2$ .
- The power supplied by the voltage source  $v_s$ .

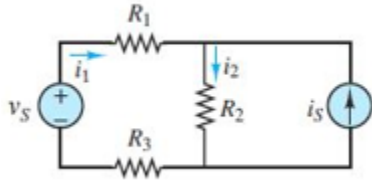

**Solution:**

**Known quantities:**

Circuit of Figure P2.37.  $R_1=20\Omega$ ,  $R_2=12\Omega$ ,  $R_3=10\Omega$ ,

$I_s=3A$ ,  $v_s=7V$ .

**Find:**

$i_1$ ,  $i_2$ , and  $P_v$ .

**Analysis:**

Use KVL of the rightmost loop:

$$v_s - R_1 * i_1 - R_2 * i_2 - R_3 * i_1 = 0$$

$$v_s = R_1 * i_1 + R_2 * i_2 + R_3 * i_1$$

Use KCL where  $i_1$  meets  $i_s$ :

$$i_1 + i_s - i_2 = 0$$

$$i_1 + i_s = i_2$$

Combine the two equations to solve for  $i_1$ :

$$v_s = R_1 * i_1 + R_2 * (i_1 + i_s) + R_3 * i_1$$

$$i_1 = -0.69A$$

Solve for  $i_2$ :

$$i_1 + i_s = i_2$$

$$i_2 = 2.31A$$

Power delivered equals the  $v_s$  times  $i_1$ :

$$P_v = v_s * i_1 = -4.83W$$

### Problem 1.38

Refer to Figure P1.38, and assume  $v_1 = 15V$ ,  $v_2 = 6V$ ,  $R_1 = 18\Omega$ ,  $R_2 = 10\Omega$ . Find:

- The currents  $i_1$  and  $i_2$ .
- The power delivered by the sources  $v_1$  and  $v_2$ .

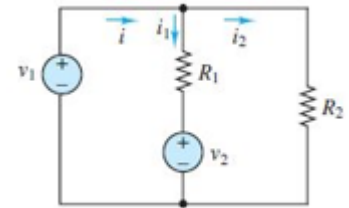

**Solution:**

**Known quantities:**

Circuit of Figure P2.38.  $R_1=18\Omega$ ,  $R_2=10\Omega$ ,  $v_1=15V$ ,  $v_2=6V$ .

**Find:**

$i_1$ ,  $i_2$ ,  $P_{v1}$ ,  $P_{v2}$ .

**Analysis:**

Use KVL of the rightmost loop:

$$v_2 + R_1 * (-i_1) - R_2 * i_2 = 0$$

$$v_2 = R_1 * i_1 + R_2 * i_2$$

Use KCL where  $i_1$  meets  $i_2$ :

$$i - i_1 - i_2 = 0$$

$$i_1 + i_2 = i$$

The assumption can be made that  $v_1$  is equal to the voltage across  $R_2$ .

$$v_2 = R_2 * i_2$$

$$i_2 = \mathbf{0.6A}$$

The assumption can be made that the voltage drop across  $R_1$  is equal to the difference between  $v_1$  and  $v_2$ .

$$v_1 - v_2 = R_1 * i_1$$

$$i_1 = \mathbf{0.5A}$$

Solve for  $i$ :

$$i_1 + i_2 = i$$

$$i = \mathbf{1.1A}$$

Power delivered equals the voltage source times the current through it:

$$P_1 = v_1 * i = \mathbf{16.5W}$$

$$P_2 = v_2 * (-i_1) = \mathbf{-3W}$$

**Problem 1.39**

Consider NiMH hobbyist batteries depicted in Figure P1.39.

a. If  $V_1 = 12.0\text{ V}$ ,  $R_1 = 0.15\ \Omega$  and  $R_o = 2.55\ \Omega$  find the load current  $I_o$  and the power dissipated by the load.

b. If battery 2 with  $V_2 = 12\text{ V}$  and  $R_2 = 0.28\ \Omega$  is placed in parallel with battery 1, will the load current  $I_o$  increase or decrease? Will the power dissipated by the load increase or decrease? By how much?

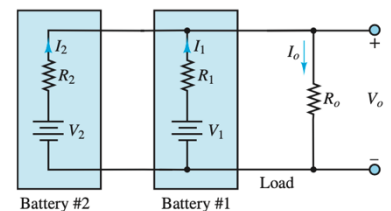
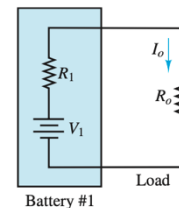

**Figure P1.39**

**Solution:****Known quantities:**

Schematic of the circuit in Figure P1.39.

**Find:**

If  $V_1 = 12.0\text{ V}$ ,  $R_1 = 0.15\ \Omega$ ,  $R_L = 2.55\ \Omega$ , the load current and the power dissipated by the load

If a second battery is connected in parallel with battery 1 with  $V_2 = 12.0\text{ V}$ ,  $R_2 = 0.28\ \Omega$ , determine the variations in the load current and in the power dissipated by the load due to the parallel connection with a second battery.

**Analysis:**

$$a) \quad I_L = \frac{V_1}{R_1 + R_L} = \frac{12}{0.15 + 2.55} = \frac{12}{2.7} = 4.44\text{ A}$$

$$P_{Load} = I_L^2 R_L = 50.4\text{ W.}$$

b) with another source in the circuit we must find the new power dissipated by the load. To do so, we write KVL twice using mesh currents to obtain 2 equations in 2 unknowns: