

Table of Contents

Chapter 1 - Problem 04	3
Chapter 1 - Problem 05	4
Chapter 1 - Problem 06	5
Chapter 1 - Problem 07	6
Chapter 1 - Problem 08	7
Chapter 1 - Problem 09	8
Chapter 1 - Problem 10	9
Chapter 1 - Problem 11	10
Chapter 1 - Problem 12	11
Chapter 1 - Problem 13	12
Chapter 1 - Problem 14	13
Chapter 1 - Problem 15	15
Chapter 1 - Problem 16	17
Chapter 1 - Problem 17	18
Chapter 1 - Problem 18	19
Chapter 1 - Problem 19	20
Chapter 1 - Problem 20	22
Chapter 1 - Problem 21	23
Chapter 1 - Problem 22	24
Chapter 1 - Problem 23	25
Chapter 1 - Problem 24	27
Chapter 1 - Problem 25	29
Chapter 1 - Problem 26	30
Chapter 1 - Problem 27	32
Chapter 1 - Problem 28	33
Chapter 1 - Problem 29	34
Chapter 1 - Problem 30	36
Chapter 1 - Problem 31	38
Chapter 1 - Problem 32	39
Chapter 1 - Problem 33	40
Chapter 1 - Problem 34	41
Chapter 1 - Problem 35	43
Chapter 1 - Problem 36	46
Chapter 1 - Problem 37	48
Chapter 1 - Problem 38	49
Chapter 1 - Problem 39	52
Chapter 1 - Problem 40	54
Chapter 1 - Problem 41	56
Chapter 1 - Problem 42	58
Chapter 1 - Problem 43	59
Chapter 1 - Problem 44	60
Chapter 1 - Problem 45	61
Chapter 1 - Problem 46	63

Chapter 1 - Problem 47	64
Chapter 1 - Problem 48	65
Chapter 1 - Problem 49	67

1.4 Perform the following unit conversions:

$$(a) 1 \text{ L} \left| \frac{0.0353 \text{ ft}^3}{1 \text{ L}} \right| \left| \frac{12 \text{ in.}}{1 \text{ ft}} \right|^3 = 61 \text{ in.}^3 \leftarrow$$

$$(b) 650 \text{ J} \left| \frac{1 \text{ kJ}}{10^3 \text{ J}} \right| \left| \frac{1 \text{ Btu}}{1.0551 \text{ kJ}} \right| = 0.616 \text{ Btu} \leftarrow$$

$$(c) 0.135 \text{ kW} \left| \frac{3413 \text{ Btu/h}}{1 \text{ kW}} \right| \left| \frac{1 \text{ h}}{3600 \text{ s}} \right| \left| \frac{778.17 \text{ ft} \cdot \text{lbf}}{1 \text{ Btu}} \right| = 99.596 \frac{\text{ft} \cdot \text{lbf}}{\text{s}} \leftarrow$$

$$(d) 378 \frac{\text{g}}{\text{s}} \left| \frac{1 \text{ kg}}{10^3 \text{ g}} \right| \left| \frac{1 \text{ lb}}{0.4536 \text{ kg}} \right| \left| \frac{60 \text{ s}}{1 \text{ min}} \right| = 50 \frac{\text{lb}}{\text{min}} \leftarrow$$

$$(e) 304 \text{ kPa} \left| \frac{1 \text{ lbf/in.}^2}{6894.8 \text{ Pa}} \right| \left| \frac{10^3 \text{ Pa}}{1 \text{ kPa}} \right| = 44.09 \frac{\text{lbf}}{\text{in.}^2} \leftarrow$$

$$(f) 55 \frac{\text{m}^3}{\text{h}} \left| \frac{3.2808 \text{ ft}}{1 \text{ m}} \right|^3 \left| \frac{1 \text{ h}}{3600 \text{ s}} \right| = 0.54 \frac{\text{ft}^3}{\text{s}} \leftarrow$$

$$(g) 50 \frac{\text{km}}{\text{h}} \left| \frac{10^3 \text{ m}}{1 \text{ km}} \right| \left| \frac{3.2808 \text{ ft}}{1 \text{ m}} \right| \left| \frac{1 \text{ h}}{3600 \text{ s}} \right| = 45.57 \frac{\text{ft}}{\text{s}} \leftarrow$$

$$(h) 8896 \text{ N} \left| \frac{1 \text{ lbf}}{4.4482 \text{ N}} \right| \left| \frac{1 \text{ ton}}{2000 \text{ lbf}} \right| = 1 \text{ ton} \leftarrow$$

1.5 Perform the following unit conversions:

$$(a) 122 \text{ in.}^3 \left| \frac{1 \text{ cm}^3}{0.061024 \text{ in.}^3} \right| \left| \frac{1 \text{ m}}{10^2 \text{ cm}} \right|^3 \left| \frac{1 \text{ L}}{10^{-3} \text{ m}^3} \right| = 2 \text{ L} \leftarrow$$

$$(b) 778.17 \text{ ft} \cdot \text{lbf} \left| \frac{1 \text{ kJ}}{737.56 \text{ ft} \cdot \text{lbf}} \right| = 1.0551 \text{ kJ} \leftarrow$$

$$(c) 100 \text{ hp} \left| \frac{1 \text{ kW}}{1.341 \text{ hp}} \right| = 74.57 \text{ kW} \leftarrow$$

$$(d) 1000 \frac{\text{lb}}{\text{h}} \left| \frac{1 \text{ h}}{3600 \text{ s}} \right| \left| \frac{1 \text{ kg}}{2.2046 \text{ lb}} \right| = 0.126 \frac{\text{kg}}{\text{s}} \leftarrow$$

$$(e) 29.392 \frac{\text{lbf}}{\text{in.}^2} \left| \frac{6894.8 \text{ Pa}}{1 \text{ lbf/in.}^2} \right| \left| \frac{1 \text{ N/m}^2}{1 \text{ Pa}} \right| \left| \frac{1 \text{ bar}}{10^5 \text{ N/m}^2} \right| = 2.027 \text{ bar} \leftarrow$$

$$(f) 2500 \frac{\text{ft}^3}{\text{min}} \left| \frac{0.028317 \text{ m}^3}{1 \text{ ft}^3} \right| \left| \frac{1 \text{ min}}{60 \text{ s}} \right| = 1.18 \frac{\text{m}^3}{\text{s}} \leftarrow$$

$$(g) 75 \frac{\text{mile}}{\text{h}} \left| \frac{1.6093 \text{ km/h}}{1 \text{ mile/h}} \right| = 120.7 \frac{\text{km}}{\text{h}} \leftarrow$$

$$(h) 1 \text{ ton} \left| \frac{2000 \text{ lbf}}{1 \text{ ton}} \right| \left| \frac{4.4482 \text{ N}}{1 \text{ lbf}} \right| = 8896 \text{ N} \leftarrow$$

1.6 Which of the following food items weighs approximately one newton?

- a. a grain of rice
- b. a small strawberry
- c. a medium-sized apple**
- d. a large watermelon

1.7 A fully-loaded shipping container has a mass of 30,000 kg. If *local* acceleration of gravity is 9.81 m/s^2 , determine the container's weight, in kN.

KNOWN: A fully-loaded shipping container has a specified mass. The local acceleration of gravity is known.

FIND: Determine the container's weight.

SCHEMATIC AND GIVEN DATA:

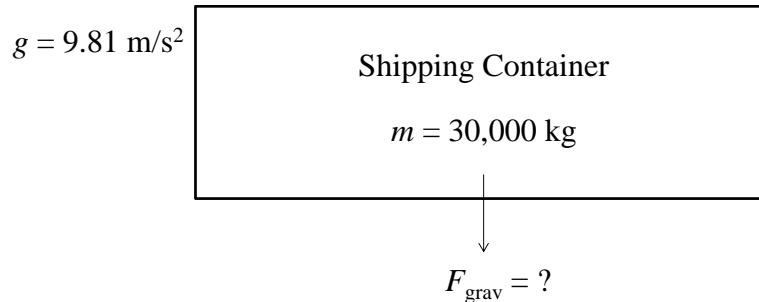

ENGINEERING MODEL:

1. Local gravitational acceleration is constant at 9.81 m/s^2 .

ANALYSIS: The force due to gravitational acceleration is computed using Eq. 1.1, where F_{grav} is the container weight and acceleration is local gravitational acceleration (g).

$$F_{\text{grav}} = mg$$

Substituting values and solving give

$$F_{\text{grav}} = (30,000 \text{ kg}) \left(9.81 \frac{\text{m}}{\text{s}^2} \right) \left| \frac{1 \text{ N}}{1 \text{ kg} \cdot \text{m/s}^2} \right| \left| \frac{1 \text{ kN}}{10^3 \text{ N}} \right| = \underline{\underline{294 \text{ kN}}}$$

1.8 The *Phoenix* with a mass of 350 kg was a spacecraft used for exploration of Mars. Determine the weight of the *Phoenix*, in N, (a) on the surface of Mars where the acceleration of gravity is 3.73 m/s^2 and (b) on Earth where the acceleration of gravity is 9.81 m/s^2 .

KNOWN: *Phoenix* spacecraft has mass of 350 kg.

FIND: (a) Weight of *Phoenix* on Mars, in N, and (b) weight of *Phoenix* on Earth, in N.

SCHEMATIC AND GIVEN DATA:

$$\begin{aligned}m &= 350 \text{ kg} \\g_{\text{Mars}} &= 3.73 \text{ m/s}^2 \\g_{\text{Earth}} &= 9.81 \text{ m/s}^2\end{aligned}$$

ENGINEERING MODEL:

1. Acceleration of gravity is constant at the surface of both Mars and Earth.

ANALYSIS: Weight is the force of gravity. Applying Newton's second law using the mass of the *Phoenix* and the local acceleration of gravity

$$F = mg$$

(a) On Mars,

$$F = (350 \text{ kg}) \left(3.73 \frac{\text{m}}{\text{s}^2} \right) \left| \frac{1 \text{ N}}{1 \text{ kg} \cdot \text{m/s}^2} \right| = \underline{1305.5 \text{ N}}$$

(b) On Earth,

$$F = (350 \text{ kg}) \left(9.81 \frac{\text{m}}{\text{s}^2} \right) \left| \frac{1 \text{ N}}{1 \text{ kg} \cdot \text{m/s}^2} \right| = \underline{3433.5 \text{ N}}$$

Although the mass of the Phoenix is constant, the weight of the Phoenix is less on Mars than on Earth since the acceleration due to gravity is less on Mars than on Earth.

1.9 Water with a density of 62.3 lb/ft^3 completely fills an 80-ft^3 vessel. If the local acceleration of gravity is 32.08 ft/s^2 , determine the weight of the water, in lbf.

KNOWN: Water of known density completely fills a vessel of known volume.

FIND: Determine weight of the water.

SCHEMATIC AND GIVEN DATA:

$$\begin{aligned}\rho_{\text{Water}} &= 62.3 \text{ lb/ft}^3 \\ g &= 32.08 \text{ ft/s}^2\end{aligned}$$

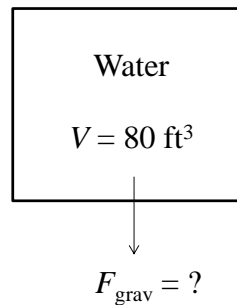

ENGINEERING MODEL:

1. Local gravitational acceleration is constant at 32.08 ft/s^2 .
2. Standard gravitational acceleration is constant at 32.174 ft/s^2 .

ANALYSIS: From Eq. 1.1 the weight of the water is the mass of water times the local acceleration of gravity.

$$F_{\text{grav}} = mg \tag{1}$$

The mass is determined using the volume of the water in the full vessel and the water density.

$$\rho = m/V \rightarrow m = \rho V$$

Solving for the mass

$$m = \left(62.3 \frac{\text{lb}}{\text{ft}^3} \right) (80 \text{ ft}^3) = 4984 \text{ lb}$$

Solving (1) for the water weight

$$F_{\text{grav}} = (4984 \text{ lb}) \left(32.08 \frac{\text{ft}}{\text{s}^2} \right) \left| \frac{1 \text{ lbf}}{32.174 \text{ lb} \cdot \text{ft/s}^2} \right| = \underline{\underline{4969 \text{ lbf}}}$$

Since the water is located in an area where the local acceleration of gravity is less than the standard acceleration of gravity, the water weighs less than an equivalent volume of water located where the acceleration of gravity is the standard value.

1.10 At the grocery store you place a pumpkin with a mass of 12.5 lb on the produce spring scale. The spring in the scale operates such that for each 4.7 lbf applied, the spring elongates one inch. If local acceleration of gravity is 32.2 ft/s², what distance, in inches, did the spring elongate?

KNOWN: Pumpkin placed on a spring scale causes the spring to elongate.

FIND: Distance spring elongated, in inches.

SCHEMATIC AND GIVEN DATA:

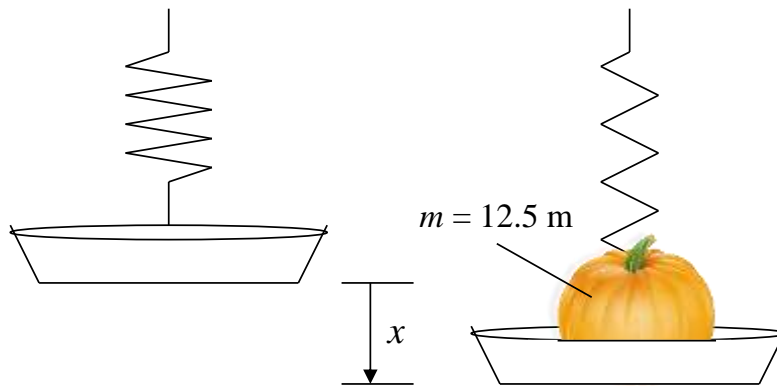

ENGINEERING MODEL:

1. Spring constant is 4.7 lbf/in.
2. Local acceleration of gravity is 32.2 ft/s².

ANALYSIS:

The force applied to the spring to cause it to elongate can be expressed as the spring constant, k , times the elongation, x .

$$F = kx$$

The applied force is due to the weight of the pumpkin, which can be expressed as the mass (m) of the pumpkin times acceleration of gravity, (g).

$$F = \text{Weight} = mg = kx$$

Solving for elongation, x , substituting values for pumpkin mass, acceleration of gravity, and spring constant, and applying the appropriate conversion factor yield

$$x = \frac{mg}{k} = \frac{(12.5 \text{ lb}) \left(32.2 \frac{\text{ft}}{\text{s}^2} \right)}{\left(4.7 \frac{\text{lbf}}{\text{in.}} \right)} \left| \frac{1 \text{ lbf}}{32.174 \frac{\text{lb} \cdot \text{ft}}{\text{s}^2}} \right| = \underline{\underline{2.66 \text{ in.}}}$$

1.11 A spring compresses in length by 0.14 in. for every 1 lbf of applied force. Determine the mass of an object, in pounds mass, that causes a spring deflection of 1.8 in. The local acceleration of gravity = 31 ft/s².

KNOWN: A spring is compressed by an object of unknown mass. The local acceleration of gravity is known.

FIND: Determine the object's mass.

SCHEMATIC AND GIVEN DATA:

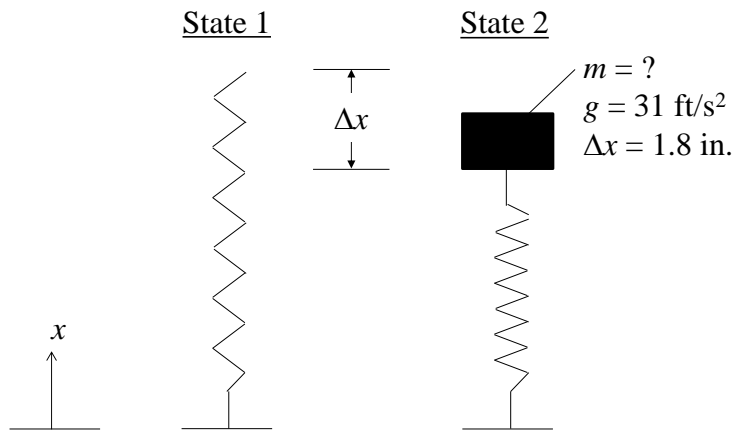

ENGINEERING MODEL:

1. Local gravitational acceleration is constant at 31 ft/s².

ANALYSIS: The spring is known to deflect 0.14 inch for every 1 lbf of applied force. Thus, we begin by determining the weight of the object (F_{grav}) using the deflection (Δx) given as 1.8 inches.

$$\Delta x = 1.8 \text{ in.} = \left(0.14 \frac{\text{in.}}{1 \text{ lbf}} \right) (F_{\text{grav}})$$

$$(F_{\text{grav}}) = \frac{1.8 \text{ in.}}{\left(0.14 \frac{\text{in.}}{1 \text{ lbf}} \right)} = 12.86 \text{ lbf}$$

The mass can be determined by using the equation, $F_{\text{grav}} = mg$.

$$m = \frac{F_{\text{grav}}}{g} = \frac{12.86 \text{ lbf}}{31 \frac{\text{ft}}{\text{s}^2}} \left| \frac{32.2 \frac{\text{lb} \cdot \text{ft}}{\text{s}^2}}{1 \text{ lbf}} \right| = \text{rounded } \underline{\underline{13.36 \text{ lb}}}$$

1.12 At a certain elevation, the pilot of a balloon has a mass of 120 lb and a weight of 119 lbf. What is the local acceleration of gravity, in ft/s^2 , at that elevation? If the balloon drifts to another elevation where $g = 32.05 \text{ ft/s}^2$, what is her weight, in lbf, and mass, in lb?

KNOWN: A pilot of a balloon has a known mass and weight at a certain elevation.

FIND: Determine the local acceleration of gravity at the certain elevation and the pilot's weight and mass at another elevation with known acceleration of gravity.

SCHEMATIC AND GIVEN DATA:

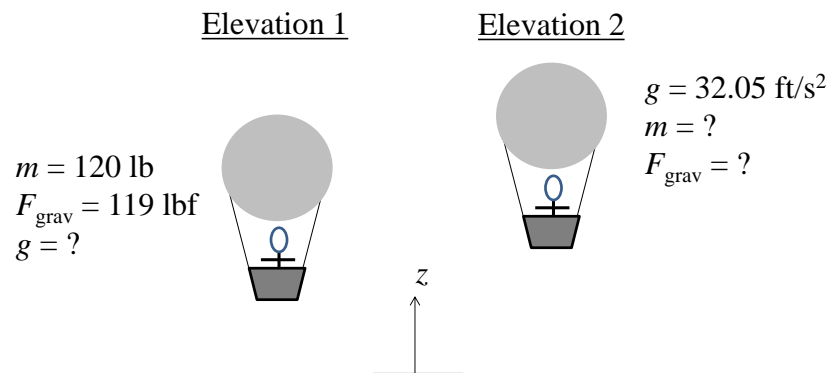

ENGINEERING MODEL:

- Local gravitational acceleration varies with elevation.

ANALYSIS: Weight refers to the force of gravity: $F_{\text{grav}} = mg$. Thus, when her mass is 120 lb and weight is 119 lbf, we have

$$g = \frac{F_{\text{grav}}}{m} = \frac{119 \text{ lbf}}{120 \text{ lb}} \left| \frac{32.174 \frac{\text{lb} \cdot \text{ft}}{\text{s}^2}}{1 \text{ lbf}} \right| = \underline{\underline{31.906 \text{ ft/s}^2}}$$

Since mass does not change with location, at the subsequent elevation, **$m = 120 \text{ lb}$** . When her mass is 120 lb and $g = 32.05 \text{ ft/s}^2$, we have

$$F_{\text{grav}} = mg = (120 \text{ lb}) \left(32.05 \frac{\text{ft}}{\text{s}^2} \right) \left| \frac{1 \text{ lbf}}{32.174 \frac{\text{lb} \cdot \text{ft}}{\text{s}^2}} \right| = \underline{\underline{119.54 \text{ lbf}}}$$

COMMENT: Her mass remains constant, but weight depends on the local acceleration of gravity.

1.13 Estimate the magnitude of the force, in lbf, exerted on a 12-lb goose in a collision of duration 10^{-3} s with an airplane taking off at 150 miles/h.

KNOWN: A goose of known mass collides with known duration with an airplane with known velocity.

FIND: Determine the magnitude of the force exerted on the goose.

SCHEMATIC AND GIVEN DATA:

$$m = 12 \text{ lb}$$
$$\Delta t = 10^{-3} \text{ s}$$

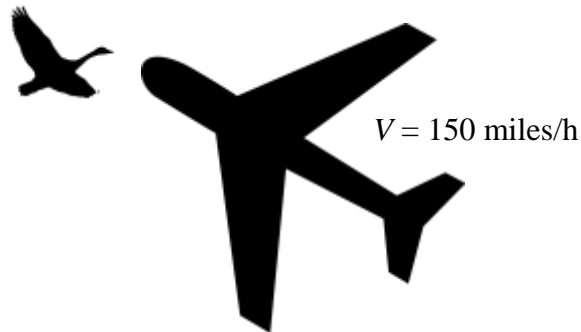

ENGINEERING MODEL:

1. Initial goose velocity is negligible compared to aircraft velocity.

ANALYSIS: The actual forces developed when birds and aircraft collide are difficult to determine precisely, but estimates can be calculated using average values of acceleration and force magnitudes as follows:

The goose is accelerated from a very low velocity to 150 miles/h in 10^{-3} s. Thus, the average acceleration magnitude is

$$|a| = \left(\frac{150 \text{ miles/h} - 0}{10^{-3} \text{ s}} \right) \left| \frac{1 \text{ h}}{3600 \text{ s}} \right| \left| \frac{5280 \text{ ft}}{1 \text{ mile}} \right| = 2.2 \times 10^5 \text{ ft/s}^2$$

The magnitude of the average force applied is

$$|F| = m|a| = (12 \text{ lb}) \left(2.2 \times 10^5 \frac{\text{ft}}{\text{s}^2} \right) \left| \frac{1 \text{ lbf}}{32.2 \frac{\text{lb} \cdot \text{ft}}{\text{s}^2}} \right| = \underline{\underline{82,000 \text{ lbf}}}$$

↑
rounded

1.14 A communications satellite weighs 4400 N on Earth where $g = 9.81 \text{ m/s}^2$. What is the weight of the satellite, in N, as it orbits Earth where the acceleration of gravity is 0.224 m/s^2 ? Express each weight in lbf.

KNOWN: Weight of communications satellite on Earth.

FIND: Determine weight of the satellite, in N, as it orbits Earth where the acceleration of gravity is 0.224 m/s^2 . Express the satellite weight, in lbf, on Earth and in orbit.

SCHEMATIC AND GIVEN DATA:

$$\begin{aligned}W_{\text{Sat(Earth)}} &= 4400 \text{ N} \\g_{\text{Earth}} &= 9.81 \text{ m/s}^2 \\g_{\text{orbit}} &= 0.224 \text{ m/s}^2\end{aligned}$$

ENGINEERING MODEL:

1. Gravitational acceleration on Earth is constant at 9.81 m/s^2 .
2. Gravitational acceleration at orbital altitude is constant at 0.224 m/s^2 .

ANALYSIS: Weight of the satellite is the force of gravity and varies with altitude. Mass of the satellite remains constant. Applying Newton's second law to solve for the mass of the satellite yields

$$W = mg \rightarrow m = W/g$$

On Earth,

$$m = W_{\text{Sat(Earth)}}/g_{\text{Earth}}$$

$$m = \frac{(4400 \text{ N})}{\left(9.81 \frac{\text{m}}{\text{s}^2}\right)} \left| \frac{1 \text{ kg} \cdot \text{m/s}^2}{1 \text{ N}} \right| = 448.5 \text{ kg}$$

Solving for the satellite weight in orbit,

$$W_{\text{Sat(orbit)}} = mg_{\text{orbit}}$$

$$W_{\text{Sat(orbit)}} = (448.5 \text{ kg}) \left(0.224 \frac{\text{m}}{\text{s}^2}\right) \left| \frac{1 \text{ N}}{1 \text{ kg} \cdot \text{m/s}^2} \right| = \mathbf{100.5 \text{ N}}$$

Although the mass of the communications satellite is constant, the weight of the satellite is less at orbital altitude than on Earth since the acceleration due to gravity is less at orbital altitude than on Earth.

To determine the corresponding weights in lbf, apply the conversion factor, 1 lbf = 4.4482 N.

$$W_{\text{Sat(Earth)}} = (4400 \text{ N}) \left| \frac{1 \text{ lbf}}{4.4482 \text{ N}} \right| = \underline{\underline{989.2 \text{ lbf}}}$$

$$W_{\text{Sat(orbit)}} = (100.5 \text{ N}) \left| \frac{1 \text{ lbf}}{4.4482 \text{ N}} \right| = \underline{\underline{22.6 \text{ lbf}}}$$

1.15 Using local acceleration of gravity data from the Internet, determine the weight, in N, of a person whose mass is 80 kg living in:

- (a) Mexico City, Mexico
- (b) Cape Town, South Africa
- (c) Tokyo, Japan
- (d) Chicago, IL
- (e) Copenhagen, Denmark

KNOWN: Person with a known mass living in multiple specified locations.

FIND: The person's weight in each location using local acceleration of gravity data from the Internet.

SCHEMATIC AND GIVEN DATA:

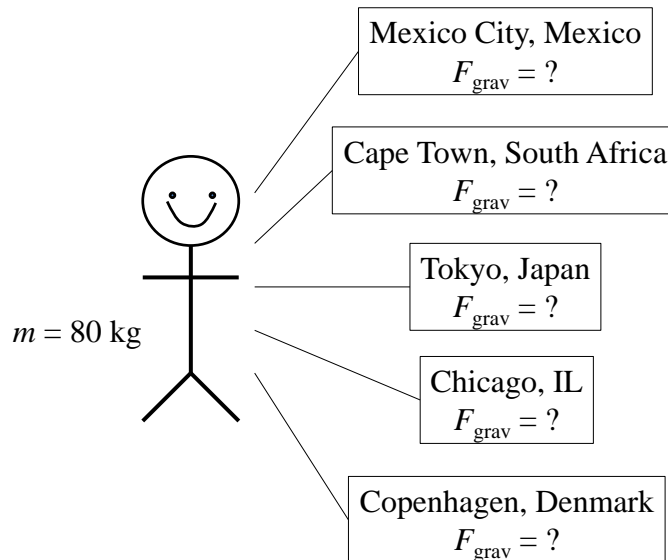

ANALYSIS:

(a) Mexico City, $g = 9.779 \text{ m/s}^2$.

$$F_{\text{grav}} = mg = (80 \text{ kg}) \left(9.779 \frac{\text{m}}{\text{s}^2} \right) \left| \frac{1 \text{ N}}{1 \frac{\text{kg} \cdot \text{m}}{\text{s}^2}} \right| = \underline{\underline{782.32 \text{ N}}}$$

(b) Cape Town, $g = 9.796 \text{ m/s}^2$.

$$F_{\text{grav}} = mg = (80 \text{ kg}) \left(9.796 \frac{\text{m}}{\text{s}^2} \right) \left| \frac{1 \text{ N}}{1 \frac{\text{kg} \cdot \text{m}}{\text{s}^2}} \right| = \underline{\underline{783.68 \text{ N}}}$$

(c) Tokyo, $g = 9.798 \text{ m/s}^2$.

$$F_{\text{grav}} = mg = (80 \text{ kg}) \left(9.798 \frac{\text{m}}{\text{s}^2} \right) \left| \frac{1 \text{ N}}{1 \frac{\text{kg} \cdot \text{m}}{\text{s}^2}} \right| = \underline{\underline{783.84 \text{ N}}}$$

(d) Chicago, $g = 9.803 \text{ m/s}^2$.

$$F_{\text{grav}} = mg = (80 \text{ kg}) \left(9.803 \frac{\text{m}}{\text{s}^2} \right) \left| \frac{1 \text{ N}}{1 \frac{\text{kg} \cdot \text{m}}{\text{s}^2}} \right| = \underline{\underline{784.24 \text{ N}}}$$

(e) Copenhagen, $g = 9.815 \text{ m/s}^2$.

$$F_{\text{grav}} = mg = (80 \text{ kg}) \left(9.815 \frac{\text{m}}{\text{s}^2} \right) \left| \frac{1 \text{ N}}{1 \frac{\text{kg} \cdot \text{m}}{\text{s}^2}} \right| = \underline{\underline{785.2 \text{ N}}}$$

1.16 A town has a 1-million-gallon storage capacity water tower. If the density of water is 62.4 lb/ft^3 and local acceleration of gravity is 32.1 ft/s^2 , what is the force, in lbf, the structural base must provide to support the water in the tower?

KNOWN: A town has a 1-million-gallon storage capacity water tower.

FIND: Determine force, in lbf, the structural base must provide to support the water in the tower.

SCHEMATIC AND GIVEN DATA:

$$\begin{aligned}\rho_{\text{Water}} &= 62.4 \text{ lb/ft}^3 \\ V &= 1 \text{ million gallons} \\ g_{\text{local}} &= 32.1 \text{ ft/s}^2\end{aligned}$$

ENGINEERING MODEL:

1. Local gravitational acceleration is constant at 32.1 ft/s^2 .
2. Standard gravitational acceleration is constant at 32.174 ft/s^2 .
3. The weight of the tower itself is ignored.

ANALYSIS: The structure must exert a minimum force equivalent to the weight of the water, which can be expressed as the mass (m) of the water times acceleration of gravity, g .

$$F = \text{Weight} = mg$$

The mass of the water can be determined from its density times the volume the water occupies

$$m = \rho V = \left(62.4 \frac{\text{lbf}}{\text{ft}^3} \right) (1,000,000 \text{ gal}) \left| \frac{0.13368 \text{ ft}^3}{1 \text{ gal}} \right| = 8,341,632 \text{ lbf}$$

Substituting for mass and acceleration of gravity and applying the appropriate conversion factor yield

$$F = mg = (8,341,632 \text{ lb}) \left(32.1 \frac{\text{ft}}{\text{s}^2} \right) \left| \frac{1 \text{ lbf}}{32.174 \text{ lb} \cdot \text{ft/s}^2} \right| = \underline{\underline{8,322,446 \text{ lbf}}}$$

Since the water is located in an area where the local acceleration of gravity is less than the standard acceleration of gravity, the water weighs less than an equivalent volume of water located where the acceleration of gravity is the standard value.

1.17 A closed system consists of 0.3 kmol of octane occupying a volume of 5 m³. Determine (a) the weight of the system, in N, and (b) the molar- and mass-based specific volumes, in m³/kmol and m³/kg, respectively. Let $g = 9.81 \text{ m/s}^2$.

KNOWN: A specified number moles of octane occupies a known volume.

FIND: Determine (a) the weight of the system, and (b) the specific volumes on molar and mass bases.

SCHEMATIC AND GIVEN DATA:

$$g = 9.81 \text{ m/s}^2$$
$$M_{\text{octane}} = 114.22 \text{ kg/kmol (Table A-1)}$$

0.3 kmol Octane (C ₈ H ₁₈) V = 5 m ³
--

ENGINEERING MODEL:

1. Octane is a closed system.
2. The acceleration of gravity is constant at 9.81 m/s².

ANALYSIS:

(a) Weight of the octane is the mass of octane times the local acceleration of gravity.

$$F_{\text{grav}} = mg_{\text{local}}$$

Using Eq. 1.8 to determine the mass of the octane

$$m = nM = (0.3 \text{ kmol}) \left(114.22 \frac{\text{kg}}{\text{kmol}} \right) = 34.266 \text{ kg}$$

Solving for the octane weight,

$$F_{\text{grav}} = (34.266 \text{ kg}) \left(9.81 \frac{\text{m}}{\text{s}^2} \right) \left| \frac{1 \text{ N}}{1 \text{ kg} \cdot \text{m/s}^2} \right| = \underline{\underline{336.1 \text{ N}}}$$

(b) Specific volume on a molar basis is

$$\bar{v} = \frac{V}{n} = \frac{5 \text{ m}^3}{0.3 \text{ kmol}} = \underline{\underline{16.67 \text{ m}^3/\text{kmol}}}$$

Specific volume on a mass basis is

$$v = \frac{V}{m} = \frac{5 \text{ m}^3}{34.266 \text{ kg}} = \underline{\underline{0.146 \text{ m}^3/\text{kg}}}$$

1.18 A 2-lb sample of an unknown liquid occupies a volume of 62.6 in.³ For the liquid determine (a) the specific volume, in ft³/lb, and (b) the density, in lb/ft³.

KNOWN: Volume and mass of an unknown liquid sample.

FIND: Determine (a) the specific volume, in ft³/lb, and (b) the density, in lb/ft³.

SCHEMATIC AND GIVEN DATA:

$$m = 2 \text{ lb}$$
$$V = 62.6 \text{ in.}^3$$

ENGINEERING MODEL:

1. The liquid can be treated as continuous.

ANALYSIS:

(a) The specific volume is volume per unit mass and can be determined from the total volume and the mass of the liquid

$$v = \frac{V}{m} = \frac{62.6 \text{ in.}^3}{2 \text{ lb}} \left| \frac{1 \text{ ft}^3}{1728 \text{ in.}^3} \right| = \underline{\underline{0.0181 \text{ ft}^3/\text{lb}}}$$

(b) Density is the reciprocal of specific volume. Thus,

$$\rho = \frac{1}{v} = \frac{1}{0.0181 \frac{\text{ft}^3}{\text{lb}}} = \underline{\underline{55.2 \text{ lb}/\text{ft}^3}}$$

1.19 A closed vessel having a volume of 1 liter holds 1.2×10^{22} molecules of nitrogen gas. For the nitrogen, determine (a) the amounts present, in kmol and kg, and (b) the specific volumes, in m^3/kmol and m^3/kg .

KNOWN: A vessel of known volume holds a specified number of molecules of nitrogen gas.

FIND: Determine (a) the mass and number of moles present, and (b) the specific volumes on molar and mass bases.

SCHEMATIC AND GIVEN DATA:

$$g = 9.81 \text{ m/s}^2$$

$$M_{\text{nitrogen}} = 28.01 \text{ kg/kmol (Table A-1)}$$

$$1.2 \times 10^{22} \text{ molecules}$$

$$\text{nitrogen gas}$$

$$V = 1 \text{ liter}$$

ENGINEERING MODEL:

1. Nitrogen is a closed system.

ANALYSIS:

(a) From Section 1.5, the number of molecules in a gram mole (mol) is 6.022×10^{23} (Avogadro's number). Thus

$$n = \frac{1.2 \times 10^{22} \text{ molecules}}{6.022 \times 10^{23} \frac{\text{molecules}}{\text{mol}}} = 0.0199 \text{ mol}$$

Converting to kmol

$$n = (0.0199 \text{ mol}) \left| \frac{1 \text{ kmol}}{10^3 \text{ mol}} \right| = \underline{\underline{1.99 \times 10^{-5} \text{ kmol}}}$$

Using Eq. 1.8 to determine the mass of the nitrogen

$$m = nM = (1.99 \times 10^{-5} \text{ kmol}) \left(28.01 \frac{\text{kg}}{\text{kmol}} \right) = \underline{\underline{5.57 \times 10^{-4} \text{ kg}}}$$

(b) Specific volume on a molar basis is

$$\bar{v} = \frac{V}{n} = \frac{1 \text{ liter}}{1.99 \times 10^{-5} \text{ kmol}} \left| \frac{10^{-3} \text{ m}^3}{1 \text{ liter}} \right| = \underline{\underline{50.25 \text{ m}^3/\text{kmol}}}$$

Specific volume on a mass basis is

$$v = \frac{V}{m} = \frac{1 \text{ liter}}{5.57 \times 10^{-4} \text{ kg}} \left| \frac{10^{-3} \text{ m}^3}{1 \text{ liter}} \right| = \underline{\underline{1.80 \text{ m}^3/\text{kg}}}$$

1.20 The specific volume of 5 kg of water vapor at 1.5 MPa, 440°C is 0.2160 m³/kg. Determine (a) the volume, in m³, occupied by the water vapor, (b) the amount of water vapor present, in gram moles, and (c) the number of molecules.

KNOWN: Mass, pressure, temperature, and specific volume of water vapor.

FIND: Determine (a) the volume, in m³, occupied by the water vapor, (b) the amount of water vapor present, in gram moles, and (c) the number of molecules.

SCHEMATIC AND GIVEN DATA:

$$\begin{aligned}m &= 5 \text{ kg} \\p &= 1.5 \text{ MPa} \\T &= 440^\circ\text{C} \\v &= 0.2160 \text{ m}^3/\text{kg}\end{aligned}$$

ENGINEERING MODEL:

1. The water vapor is a closed system.

ANALYSIS:

(a) The specific volume is volume per unit mass. Thus, the volume occupied by the water vapor can be determined by multiplying its mass by its specific volume.

$$V = mv = (5 \text{ kg}) \left(0.2160 \frac{\text{m}^3}{\text{kg}} \right) = \underline{1.08 \text{ m}^3}$$

(b) Using molecular weight of water from Table A-1 and applying the appropriate relation to convert the water vapor mass to gram moles gives

$$n = \frac{m}{M} = \left(\frac{5 \text{ kg}}{18.02 \frac{\text{kg}}{\text{kmol}}} \right) \left| \frac{1000 \text{ moles}}{1 \text{ kmol}} \right| = \underline{277.5 \text{ moles}}$$

(c) Using Avogadro's number to determine the number of molecules yields

$$\# \text{ Molecules} = \text{Avogadro's Number} \times \# \text{ moles} = \left(6.022 \times 10^{23} \frac{\text{molecules}}{\text{mole}} \right) (277.5 \text{ moles})$$

$$\# \text{ Molecules} = \underline{1.671 \times 10^{26} \text{ molecules}}$$

1.21 The pressure of the gas contained in the piston-cylinder assembly of Fig. 1.1 varies with its volume according to $p = A + (B/V)$, where A, B are constants. If pressure is in lbf/ft^2 and volume is in ft^3 , what are the units of A and B?

KNOWN: Relationship between pressure and volume.

FIND: Determine units of A and B.

SCHEMATIC AND GIVEN DATA:

$$p \text{ [lbf/ft}^2\text{]}$$

$$V \text{ [ft}^3\text{]}$$

$$p = A + (B/V), \text{ where A and B are constants}$$

ENGINEERING MODEL:

1. The gas is a closed system.

ANALYSIS:

$$p = A + \frac{B}{V}$$

\uparrow \swarrow
 $\left[\frac{\text{lbf}}{\text{ft}^2} \right]$ $[\text{ft}^3]$

By inspection of this equation, **A has units of lbf/ft².**

Rearranging,

$$B = \underbrace{[p - A]}_{\left[\frac{\text{lbf}}{\text{ft}^2} \right]} \underbrace{V}_{[\text{ft}^3]}$$

\Rightarrow **B has units of ft·lbf.**

1.22 As shown in Figure P1.22, a vertical piston-cylinder assembly containing a gas is placed on a hot plate. The piston initially rests on the stops. With the onset of heating, the gas pressure increases. At what pressure, in bar, does the piston start rising? The piston moves smoothly in the cylinder and $g = 9.81 \text{ m/s}^2$.

KNOWN: A piston-cylinder assembly contains gas that is heated.

FIND: At what pressure the piston starts rising.

SCHEMATIC AND GIVEN DATA:

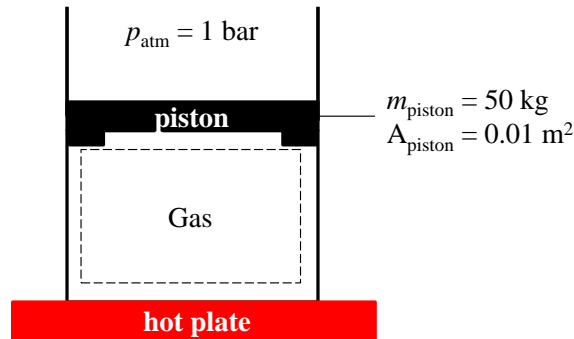

ENGINEERING MODEL:

1. The gas is a closed system.
2. The piston is in static equilibrium.
3. Atmospheric pressure is exerted on the top of the piston.
4. Local gravitational acceleration is 9.81 m/s^2 .

ANALYSIS:

Since the piston moves smoothly within the cylinder, the piston begins to rise when the force exerted by the gas exceeds the resisting force comprised of the piston weight and the force exerted by the atmospheric pressure. That is,

$$F_{\text{gas}} \geq \text{Weight} + F_{\text{atm}}$$

$$p_{\text{gas}} A_{\text{piston}} \geq m_{\text{piston}} g + p_{\text{atm}} A_{\text{piston}}$$

$$p_{\text{gas}} \geq \frac{m_{\text{piston}} g}{A_{\text{piston}}} + p_{\text{atm}}$$

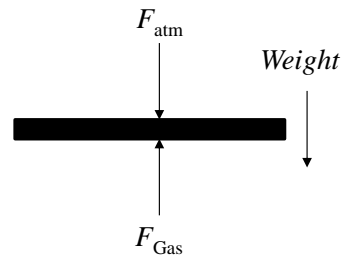

$$p_{\text{gas}} \geq \left[\frac{(50 \text{ kg}) \left(9.81 \frac{\text{m}}{\text{s}^2} \right)}{0.01 \text{ m}^2} \right] \left\| \frac{1 \text{ bar}}{10^5 \frac{\text{N}}{\text{m}^2}} \right\| \left\| \frac{1 \text{ N}}{1 \frac{\text{kg} \cdot \text{m}}{\text{s}^2}} \right\| + 1 \text{ bar} \rightarrow p_{\text{gas}} \geq \underline{\underline{1.49 \text{ bar}}}$$

1.23 A closed system consisting of 4 lb of a gas undergoes a process during which the relation between pressure and volume is $pV^n = \text{constant}$. The process begins with $p_1 = 15 \text{ lbf/in.}^2$, $v_1 = 1.25 \text{ ft}^3/\text{lb}$ and ends with $p_2 = 53 \text{ lbf/in.}^2$, $v_2 = 0.5 \text{ ft}^3/\text{lb}$. Determine (a) the volume, in ft^3 , occupied by the gas at states 1 and 2 and (b) the value of n . (c) Sketch Process 1-2 on pressure-volume coordinates.

KNOWN: Gas undergoes a process from a known initial pressure and specific volume to a known final pressure and specific volume.

FIND: Determine (a) the volume, in ft^3 , occupied by the gas at states 1 and 2 and (b) the value of n . (c) Sketch Process 1-2 on pressure-volume coordinates.

SCHEMATIC AND GIVEN DATA:

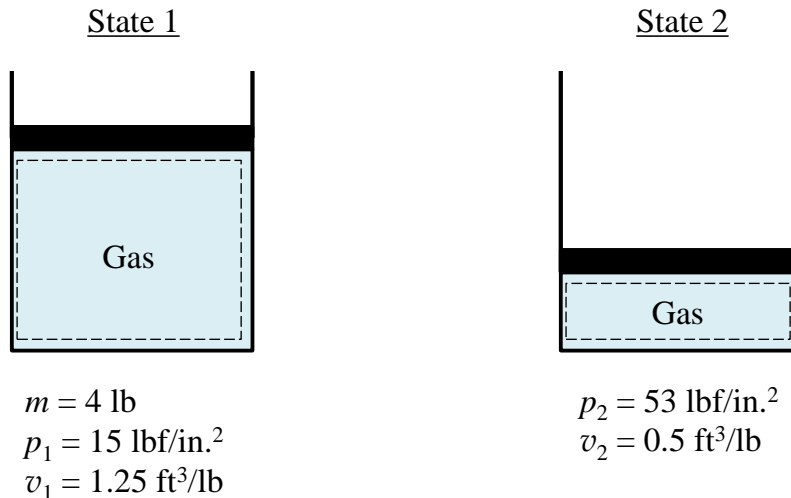

ENGINEERING MODEL:

1. The gas is a closed system.
2. The relation between pressure and volume is $pV^n = \text{constant}$ during process 1-2.

ANALYSIS:

(a) The specific volume is volume per unit mass. Thus, the volume occupied by the gas can be determined by multiplying its mass by its specific volume.

$$V = mv$$

For state 1

$$V_1 = mv_1 = (4 \text{ lb}) \left(1.25 \frac{\text{ft}^3}{\text{lb}} \right) = \underline{5 \text{ ft}^3}$$

For state 2

$$V_2 = mv_2 = (4 \text{ lb}) \left(0.5 \frac{\text{ft}^3}{\text{lb}} \right) = \underline{2 \text{ ft}^3}$$

(b) The value of n can be determined by substituting values into the relationship:

$$p_1(V_1)^n = \text{constant} = p_2(V_2)^n$$

Solving for n

$$\frac{p_1}{p_2} = \left(\frac{V_2}{V_1}\right)^n$$

$$\ln\left(\frac{p_1}{p_2}\right) = n \ln\left(\frac{V_2}{V_1}\right)$$

$$n = \frac{\ln\left(\frac{p_1}{p_2}\right)}{\ln\left(\frac{V_2}{V_1}\right)} = \frac{\ln\left(\frac{15 \text{ lbf/in.}^2}{53 \text{ lbf/in.}^2}\right)}{\ln\left(\frac{2 \text{ ft}^3}{5 \text{ ft}^3}\right)} = \underline{\underline{1.38}}$$

(c) Process 1-2 is shown on pressure-volume coordinates below:

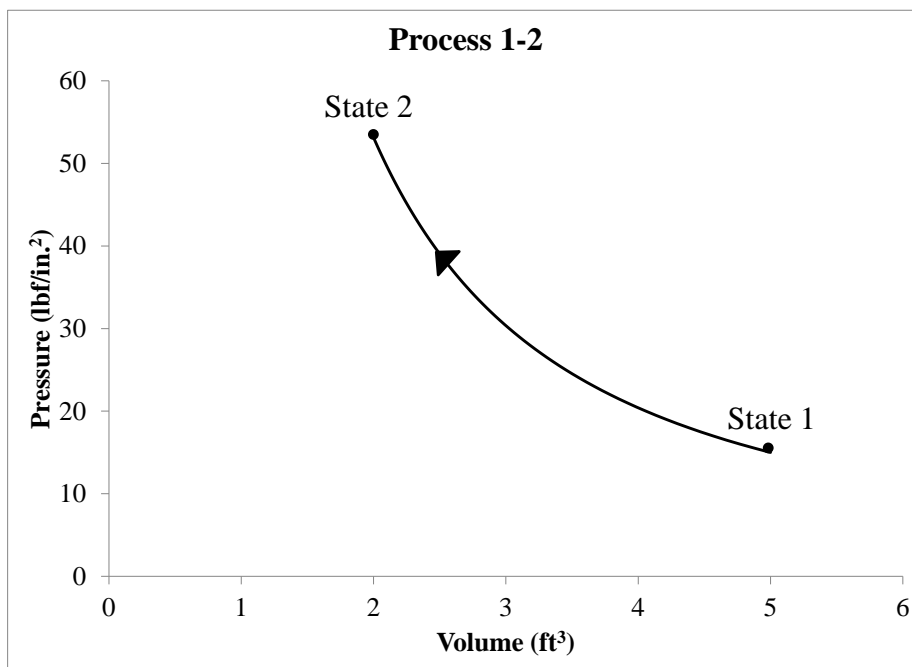

1.24 Figure P1.24 shows a gas contained in a vertical piston-cylinder assembly. A vertical shaft whose cross-sectional area is 0.8 cm^2 is attached to the top of the piston. Determine the magnitude, F , of the force acting on the shaft, in N, required if the gas pressure is 3 bar. The masses of the piston and attached shaft are 24.5 kg and 0.5 kg, respectively. The piston diameter is 10 cm. The local atmospheric pressure is 1 bar. The piston moves smoothly in the cylinder and $g = 9.81 \text{ m/s}^2$.

KNOWN: A piston-cylinder assembly with a vertical shaft attached to the piston contains gas.

FIND: The required magnitude of the force acting on the shaft if the gas is at a specified pressure.

SCHEMATIC AND GIVEN DATA:

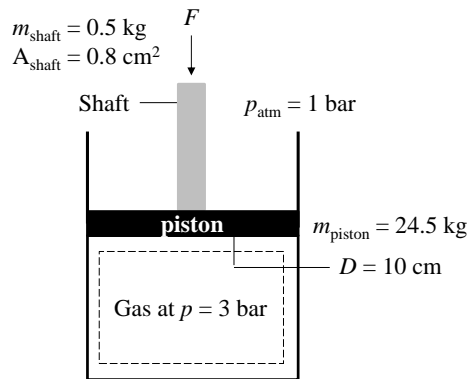

ENGINEERING MODEL:

1. The gas is a closed system.
2. The piston is in static equilibrium.
3. Atmospheric pressure is exerted on the top of the piston.
4. Local gravitational acceleration is 9.81 m/s^2 .

ANALYSIS:

Since the piston moves smoothly within the cylinder, the force exerted by the gas equals the resisting force comprised of the piston weight, shaft weight, the force exerted by the atmospheric pressure, and the force acting on the shaft, F . That is, the sum of the forces acting vertically is zero, giving

$$F_{\text{gas}} = \text{Piston Weight} + \text{Shaft Weight} + F_{\text{atm}} + F$$

Solving,

$$F = F_{\text{gas}} - \text{Piston Weight} - \text{Shaft Weight} - F_{\text{atm}} \quad (*)$$

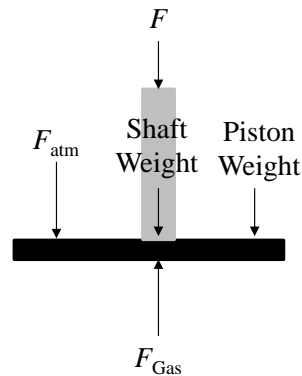

In this expression,

$F_{\text{gas}} = p_{\text{gas}}A_{\text{piston}}$, where A_{piston} is the piston force area:

$$A_{\text{piston}} = \frac{\pi D_{\text{piston}}^2}{4} = \frac{\pi(10 \text{ cm})^2}{4} = 78.54 \text{ cm}^2$$

$$\text{Therefore, } F_{\text{gas}} = (3 \text{ bar}) \left| \frac{10^5 \frac{\text{N}}{\text{m}^2}}{1 \text{ bar}} \right| (78.54 \text{ cm}^2) \left| \frac{1 \text{ m}}{10^2 \text{ cm}} \right|^2 = 2356.2 \text{ N}$$

The pressure of the atmosphere acts only on the net area at the top of the piston – namely, the piston face area less the area occupied by the shaft. The force is then

$$F_{\text{atm}} = p_{\text{atm}}(A_{\text{piston}} - A_{\text{shaft}})$$

$$F_{\text{atm}} = (1 \text{ bar})(78.54 \text{ cm}^2 - 0.8 \text{ cm}^2) \left| \frac{10^5 \frac{\text{N}}{\text{m}^2}}{1 \text{ bar}} \right| \left| \frac{1 \text{ m}}{10^2 \text{ cm}} \right|^2 = 777.4 \text{ N}$$

The total weight of the piston and shaft is

$$\text{Total Weight} = (m_{\text{piston}} + m_{\text{shaft}})g$$

$$\text{Total Weight} = (24.5 \text{ kg} + 0.5 \text{ kg}) \left(9.81 \frac{\text{m}}{\text{s}^2} \right) \left| \frac{1 \text{ N}}{1 \frac{\text{kg} \cdot \text{m}}{\text{s}^2}} \right| = 245.3 \text{ N}$$

Collecting results, Eq. (*) gives

$$F = 2356.2 \text{ N} - 245.3 \text{ N} - 777.4 \text{ N} = \underline{\underline{1333.5 \text{ N}}}$$

1.25 A gas contained within a piston-cylinder assembly undergoes four processes in series:

Process 1-2: Constant-pressure expansion at 1 bar from $V_1 = 0.5 \text{ m}^3$ to $V_2 = 2 \text{ m}^3$

Process 2-3: Constant volume to 2 bar

Process 3-4: Constant-pressure compression to 1 m^3

Process 4-1: Compression with $pV^{-1} = \text{constant}$

Sketch the process in series on a p - V diagram labeled with pressure and volume values at each numbered state.

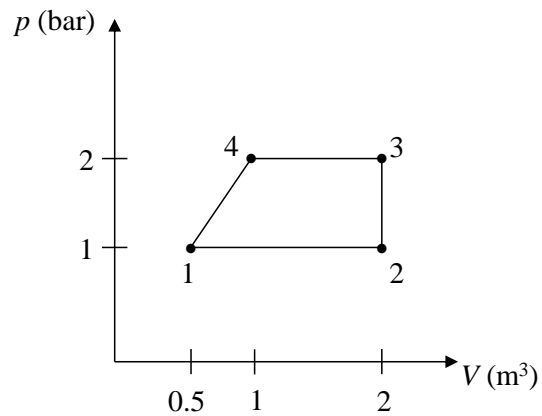

1.26 Referring to Fig. 1.7,

(a) if the pressure in the tank is 1.5 bar and atmospheric pressure is 1 bar, determine L , in m, for water with a density of 997 kg/m^3 as the manometer liquid. Let $g = 9.81 \text{ m/s}^2$.

(b) determine L , in cm, if the manometer liquid is mercury with a density of 13.59 g/cm^3 and the gas pressure is 1.3 bar. A barometer indicates the local atmospheric pressure is 750 mmHg. Let $g = 9.81 \text{ m/s}^2$.

KNOWN: A manometer is attached to a tank containing a gas.

FIND: L considering two different manometer liquids with associated gas pressures.

SCHEMATIC AND GIVEN DATA:

(a) $p_{\text{gas}} = 1.5 \text{ bar}$
 $p_{\text{atm}} = 1 \text{ bar}$
 $\rho_{\text{water}} = 997 \text{ kg/m}^3$

(b) $p_{\text{gas}} = 1.3 \text{ bar}$
 $p_{\text{atm}} = 750 \text{ mmHg}$
 $\rho_{\text{mercury}} = 13.59 \text{ g/cm}^3$

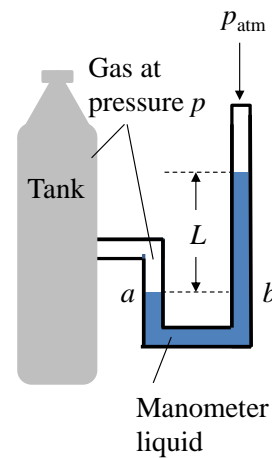

ENGINEERING MODEL:

1. Local gravitational acceleration is 9.81 m/s^2 .

ANALYSIS:

(a) We have $p_a = p_{\text{gas}}$ and $p_a = p_b$. p_b is evaluated using Eq. 1.11. Collecting results,

$$p_{\text{gas}} = p_{\text{atm}} + \rho_w g L$$

where $\rho_w = 997 \text{ kg/m}^3$ and $g = 9.81 \text{ m/s}^2$.

Solving for L

$$L = \frac{p_{\text{gas}} - p_{\text{atm}}}{\rho_w g} = \frac{(1.5 - 1) \text{ bar}}{\left(997 \frac{\text{kg}}{\text{m}^3}\right) \left(9.81 \frac{\text{m}}{\text{s}^2}\right)} \left| \frac{10^5 \frac{\text{N}}{\text{m}^2}}{1 \text{ bar}} \right| \left| \frac{1 \frac{\text{kg} \cdot \text{m}}{\text{s}^2}}{1 \text{ N}} \right| = \underline{\underline{5.11 \text{ m}}}$$

(b) First solve for p_{atm} with $L = 750 \text{ mmHg}$ and $\rho_{\text{mercury}} = 13.59 \text{ g/cm}^3$.

$$p_{\text{atm}} = \rho_{\text{mercury}} g L$$

$$p_{\text{atm}} = \left(13.59 \frac{\text{g}}{\text{cm}^3} \right) \left| \frac{1 \text{ kg}}{10^3 \text{ g}} \right| \left| \frac{10^2 \text{ cm}}{1 \text{ m}} \right|^3 \left(9.81 \frac{\text{m}}{\text{s}^2} \right) (750 \text{ mmHg}) \left| \frac{1 \text{ m}}{10^3 \text{ mm}} \right| \left| \frac{1 \text{ N}}{1 \frac{\text{kg} \cdot \text{m}}{\text{s}^2}} \right| = 10^5 \text{ N/m}^2$$

Following the approach of part (a) and solving for L

$$L = \frac{p_{\text{gas}} - p_{\text{atm}}}{\rho_w g} = \frac{(1.3 - 1) \text{ bar}}{\left(13.59 \frac{\text{g}}{\text{cm}^3} \right) \left(9.81 \frac{\text{m}}{\text{s}^2} \right)} \left| \frac{10^3 \text{ g}}{1 \text{ kg}} \right| \left| \frac{1 \text{ m}}{10^2 \text{ cm}} \right|^3 \left| \frac{10^5 \frac{\text{N}}{\text{m}^2}}{1 \text{ bar}} \right| \left| \frac{1 \frac{\text{kg} \cdot \text{m}}{\text{s}^2}}{1 \text{ N}} \right| \left| \frac{100 \text{ cm}}{1 \text{ m}} \right| = \underline{\underline{22.5 \text{ cm}}}$$

1.27 Figure P1.27 shows a storage tank holding natural gas. In an adjacent instrument room, a U-tube mercury manometer in communication with the storage tank reads $L = 1.0$ m. If the atmospheric pressure is 101 kPa, the density of the mercury is 13.59 g/cm^3 , and $g = 9.81 \text{ m/s}^2$, determine the pressure of the natural gas, in kPa.

KNOWN: A manometer is in communication with natural gas in a storage tank.

FIND: The pressure of the natural gas.

SCHEMATIC AND GIVEN DATA:

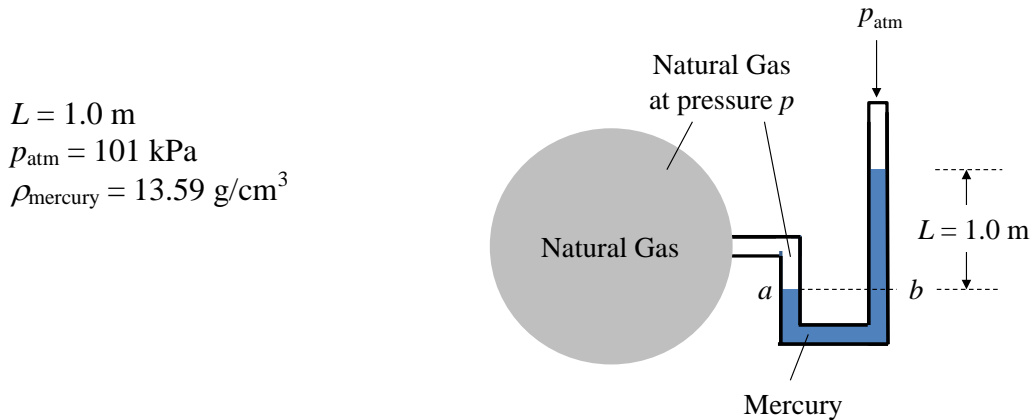

$$\begin{aligned}
 L &= 1.0 \text{ m} \\
 p_{\text{atm}} &= 101 \text{ kPa} \\
 \rho_{\text{mercury}} &= 13.59 \text{ g/cm}^3
 \end{aligned}$$

ENGINEERING MODEL:

1. Local gravitational acceleration is 9.81 m/s^2 .

ANALYSIS:

Considering a manometer connected to the storage tank by a line filled with gas, we have $p_a = p_{\text{gas}}$ and $p_a = p_b$. p_b is evaluated using Eq. 1.11. Collecting results,

$$p_{\text{gas}} = p_{\text{atm}} + \rho g L$$

$$p_{\text{gas}} = 101 \text{ kPa} + \left(13.59 \frac{\text{g}}{\text{cm}^3} \right) \left| \frac{1 \text{ kg}}{10^3 \text{ g}} \right| \left| \frac{10^2 \text{ cm}}{1 \text{ m}} \right|^3 \left(9.81 \frac{\text{m}}{\text{s}^2} \right) (1.0 \text{ m}) \left| \frac{1 \text{ N}}{1 \frac{\text{kg} \cdot \text{m}}{\text{s}^2}} \right| \left| \frac{1 \text{ kPa}}{10^3 \frac{\text{N}}{\text{m}^2}} \right|$$

$$p_{\text{gas}} = 101 \text{ kPa} + 133.3 \text{ kPa}$$

$$p_{\text{gas}} = \underline{\underline{234.3 \text{ kPa}}}$$

1.28 As shown in Figure P1.28, the exit of a gas compressor empties into a receiver tank, maintaining the tank contents at a pressure of 200 kPa. If the local atmospheric pressure is 1 bar, what is the reading of the Bourdon gage mounted on the tank wall in kPa? Is this a *vacuum* pressure or a *gage* pressure? Explain.

KNOWN: The exit of a gas compressor empties into a receiver tank.

FIND: The Bourdon gage reading. Identify whether the reading is a *vacuum* pressure or a *gage* pressure and explain.

SCHEMATIC AND GIVEN DATA:

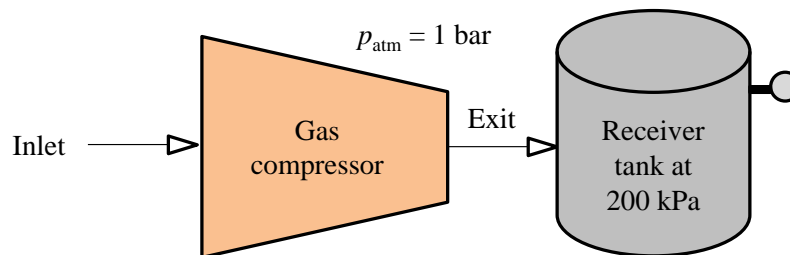

ANALYSIS:

Converting the local atmospheric pressure to kPa, we get $p_{\text{atm}} = 100 \text{ kPa}$. Since the pressure in the tank, 200 kPa, is greater than the atmospheric pressure, **the Bourdon reading is a gage pressure**. Using the relationship

$$p_{\text{gage}} = p_{\text{abs}} - p_{\text{atm}} = 200 \text{ kPa} - 100 \text{ kPa} = 100 \text{ kPa}$$

The Bourdon reading is 100 kPa.

1.29 Liquid kerosene flows through a Venturi meter, as shown in Fig. P1.29. The pressure of the kerosene in the pipe supports columns of kerosene that differ in height by 12 cm. Determine the difference in pressure between points a and b, in kPa. Does the pressure increase or decrease as the kerosene flows from point a to point b as the pipe diameter decreases? The atmospheric pressure is 101 kPa, the specific volume of kerosene is $0.00122 \text{ m}^3/\text{kg}$, and the acceleration of gravity is $g = 9.81 \text{ m/s}^2$.

KNOWN: Kerosene flows through a Venturi meter.

FIND: The pressure difference between points a and b, in kPa and whether pressure increases or decreases as the kerosene flows from point a to point b as the pipe diameter decreases.

SCHEMATIC AND GIVEN DATA:

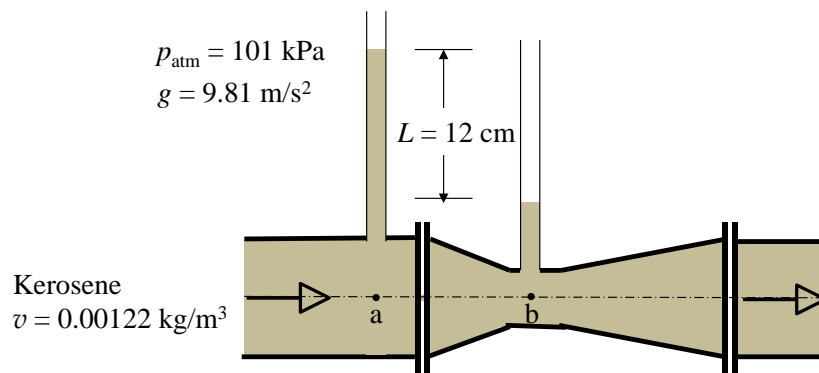

ENGINEERING MODEL:

1. The kerosene is incompressible.
2. Atmospheric pressure is exerted at the open end of the fluid columns.

ANALYSIS:

Equation 1.11 applies to both columns of fluid (a and b). Let h_b be the height of the fluid above point b. Then $h_b + L$ is the height of the fluid above point a. Applying Eq. 1.11 to each column yields

$$p_a = p_{\text{atm}} + \rho g(h_b + L) = p_{\text{atm}} + \rho g h_b + \rho g L$$

and

$$p_b = p_{\text{atm}} + \rho g h_b$$

Thus, the difference in pressure between point a and point b is

$$\Delta p = p_b - p_a = (p_{\text{atm}} + \rho g h_b) - (p_{\text{atm}} + \rho g h_b + \rho g L)$$

$$\Delta p = -\rho g L$$

Density of kerosene is the reciprocal of its specific volume

$$\rho = 1/v = 1/0.00122 \text{ m}^3/\text{kg} = 820 \text{ kg/m}^3$$

Solving for the difference in pressure yields

$$\Delta p = -\left(820 \frac{\text{kg}}{\text{m}^3}\right)\left(9.81 \frac{\text{m}}{\text{s}^2}\right)(12 \text{ cm}) \left| \frac{1 \text{ N}}{1 \frac{\text{kg} \cdot \text{m}}{\text{s}^2}} \right| \left| \frac{1 \text{ m}}{100 \text{ cm}} \right| \left| \frac{1 \text{ kPa}}{1000 \frac{\text{N}}{\text{m}^2}} \right| = \underline{\underline{-0.965 \text{ kPa}}}$$

Since points a and b are at the same elevation in the flow, the difference in pressure is indicated by the difference in height between the two columns. **The negative sign indicates pressure decreases as the kerosene flows from point a to point b as the pipe diameter decreases.**

1.30 Figure P1.30 shows a tank within a tank, each containing air. Pressure gage A, which indicates pressure inside tank A, is located inside tank B and reads 5 psig (vacuum). The U-tube manometer connected to tank B contains water with a column length of 10 in. Using data on the diagram, determine the absolute pressure of the air inside tank B and inside tank A, both in psia. The atmospheric pressure surrounding tank B is 14.7 psia. The acceleration of gravity is $g = 32.2 \text{ ft/s}^2$.

KNOWN: A tank within a tank, each containing air.

FIND: Absolute pressure of air in tank B and in tank A, both in psia.

SCHEMATIC AND GIVEN DATA:

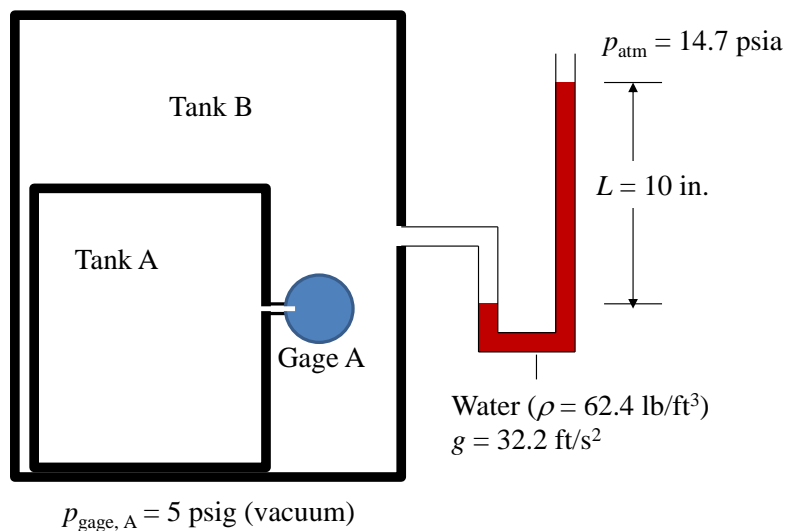

ENGINEERING MODEL:

1. The gas is a closed system.
2. Atmospheric pressure is exerted at the open end of the manometer.
3. The manometer fluid is water with a density of 62.4 lb/ft^3 .

ANALYSIS:

(a) Applying Eq. 1.11

$$p_{\text{gas,B}} = p_{\text{atm}} + \rho g L$$

where p_{atm} is the local atmospheric pressure to tank B, ρ is the density of the manometer fluid (water), g is the acceleration due to gravity, and L is the column length of the manometer fluid. Substituting values

$$p_{\text{gas,B}} = 14.7 \frac{\text{lbf}}{\text{in.}^2} + \left(62.4 \frac{\text{lb}}{\text{ft}^3} \right) \left(32.2 \frac{\text{ft}}{\text{s}^2} \right) (10 \text{ in.}) \left| \frac{1 \text{ lbf}}{32.2 \frac{\text{lbm} \cdot \text{ft}}{\text{s}^2}} \right| \left| \frac{1 \text{ ft}^3}{1728 \text{ in.}^3} \right| = \underline{15.1 \text{ lbf/in.}^2}$$

Since the gage pressure of the air in tank A is a vacuum, Eq. 1.15 applies.

$$p(\text{vacuum}) = p_{\text{atm}}(\text{absolute}) - p(\text{absolute})$$

The pressure of the gas in tank B is the local atmospheric pressure to tank A. Solving for p (absolute) and substituting values yield

$$p(\text{absolute}) = p_{\text{atm}}(\text{absolute}) - p(\text{vacuum}) = 15.1 \text{ psia} - 5 \text{ psig} = \mathbf{10.1 \text{ psia}}$$

1.31 The Mariana Trench in the western Pacific Ocean includes the greatest known ocean depth at approximately 6.8 miles. The atmosphere exerts a pressure of 14.7 lbf/in.^2 at the ocean surface. Modeling the ocean seawater as static and assuming constant local acceleration of gravity of 32.1 ft/s^2 and constant seawater density of 64.2 lb/ft^3 , determine the absolute pressure, in lbf/in.^2 , at this depth.

KNOWN: The Mariana Trench in the western Pacific Ocean includes the greatest known ocean depth.

FIND: The absolute pressure at the greatest depth in the Mariana Trench.

SCHEMATIC AND GIVEN DATA:

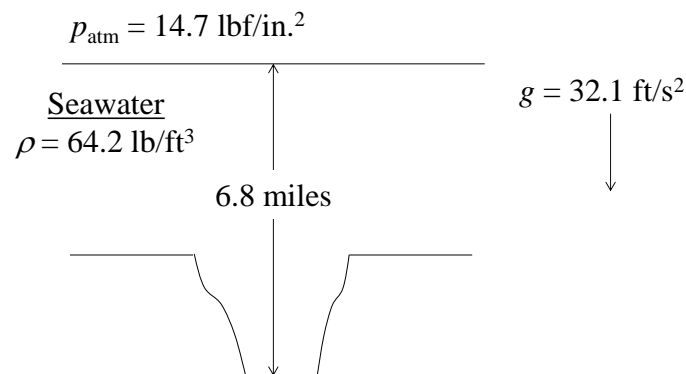

ENGINEERING MODEL:

1. Local gravitational acceleration is 32.1 ft/s^2 .
2. Seawater density is constant at 62.4 lb/ft^3 .
3. The ocean seawater is modeled as static.

ANALYSIS: The pressure acting at the bottom of the Mariana Trench at a depth of 6.8 miles is

$$p = p_{\text{atm}} + \rho g L$$

Substituting values and applying unit conversions yield

$$p = 14.7 \frac{\text{lbf}}{\text{in.}^2} + \left(64.2 \frac{\text{lb}}{\text{ft}^3} \right) \left(32.1 \frac{\text{ft}}{\text{s}^2} \right) (6.8 \text{ mi}) \left| \frac{5280 \text{ ft}}{\text{mi}} \right| \left| \frac{1 \text{ ft}^2}{144 \text{ in.}^2} \right| \left| \frac{1 \text{ lbf}}{32.174 \frac{\text{lb} \cdot \text{ft}}{\text{s}^2}} \right| = \underline{\underline{15,985 \text{ lbf/in.}^2}}$$

1.32 Show that a standard atmospheric pressure of 760 mmHg is equivalent to 101.3 kPa. The density of mercury is $13,590 \text{ kg/m}^3$ and $g = 9.81 \text{ m/s}^2$.

KNOWN: Standard atmospheric pressure of 760 mmHg.

FIND: Show that 760 mmHg is equivalent to 101.3 kPa.

SCHEMATIC AND GIVEN DATA:

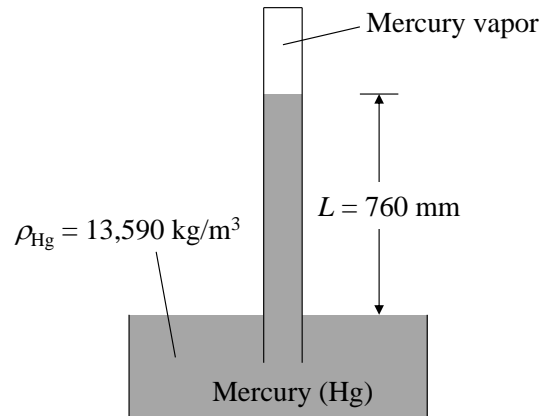

ENGINEERING MODEL:

1. Local gravitational acceleration is 9.81 m/s^2 .
2. Pressure of mercury vapor is much less than that of the atmosphere and can be neglected.

ANALYSIS:

Equation 1.12 applies.

$$p_{\text{atm}} = p_{\text{vapor}} + \rho_{\text{Hg}} g L = \rho_{\text{Hg}} g L$$

Neglecting the pressure of mercury vapor and applying appropriate conversion factors yield

$$p_{\text{atm}} = \left(13,590 \frac{\text{kg}}{\text{m}^3} \right) \left(9.81 \frac{\text{m}}{\text{s}^2} \right) (760 \text{ mm}) \left| \frac{1 \text{ N}}{1 \frac{\text{kg} \cdot \text{m}}{\text{s}^2}} \right| \left| \frac{1 \text{ m}}{1000 \text{ mm}} \right| \left| \frac{1 \text{ kPa}}{1000 \frac{\text{N}}{\text{m}^2}} \right| = \underline{\underline{101.3 \text{ kPa}}}$$

1.33 A gas enters a compressor that provides a pressure ratio (exit pressure to inlet pressure) equal to 8. If a gage indicates the gas pressure at the inlet is 5.5 psig, what is the absolute pressure, in psia, of the gas at the exit? Atmospheric pressure is 14.5 lbf/in.²

KNOWN: Gas pressure is measured at the inlet of a compressor for which the pressure ratio is known.

FIND: Determine the absolute pressure of the gas at the compressor exit.

SCHEMATIC AND GIVEN DATA:

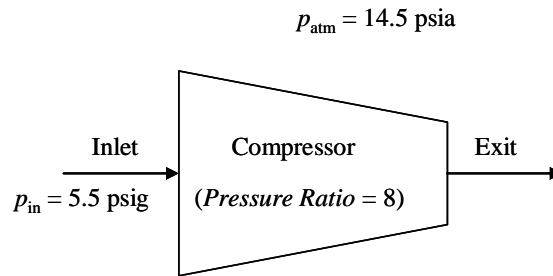

ENGINEERING MODEL:

1. Atmospheric pressure is 14.5 lbf/in.²

ANALYSIS:

From the compressor pressure ratio, the exit pressure can be determined from

$$\text{pressure ratio} = p_{\text{exit}}/p_{\text{in}} \quad \rightarrow \quad p_{\text{exit}} = p_{\text{in}}(\text{pressure ratio})$$

Inlet pressure must be expressed as absolute pressure to solve for exit pressure. Conversion from the inlet pressure gage reading to absolute pressure is determined from

$$p_{\text{in}}(\text{gage}) = p_{\text{in}}(\text{absolute}) - p_{\text{atm}}(\text{absolute})$$

Rearranging the equation to solve for $p_{\text{in}}(\text{absolute})$ and substituting values yield

$$p_{\text{in}}(\text{absolute}) = p_{\text{in}}(\text{gage}) + p_{\text{atm}}(\text{absolute}) = 5.5 \text{ psig} + 14.5 \text{ psia} = 20 \text{ psia}$$

Substituting absolute pressure at the inlet into the equation for exit pressure yields

$$p_{\text{exit}} = (20 \text{ psia})(8) = \underline{\underline{160 \text{ psia}}}$$

1.34 As shown in Figure P1.34, air is contained in a vertical piston-cylinder assembly such that the piston is in static equilibrium. The atmosphere exerts a pressure of 14.7 lbf/in.^2 on top of the 6-in.-diameter piston. The absolute pressure of the air inside the cylinder is 16 lbf/in.^2 . The local acceleration of gravity is $g = 32.2 \text{ ft/s}^2$. Determine (a) the mass of the piston, in lb, and (b) the gage pressure of the air in the cylinder, in psig.

KNOWN: A piston-cylinder assembly contains air such that the piston is in static equilibrium.

FIND: (a) The mass of the piston, in lb, and (b) the gage pressure of the air in the cylinder, in psig.

SCHEMATIC AND GIVEN DATA:

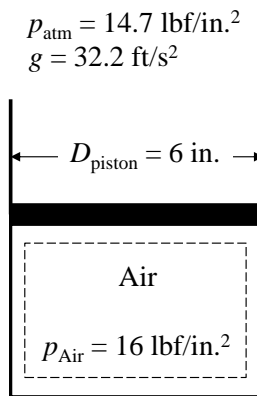

ENGINEERING MODEL:

1. The air is a closed system.
2. The piston is in static equilibrium.
3. Atmospheric pressure is exerted on the top of the piston.
4. Local gravitational acceleration is 32.2 ft/s^2 .

ANALYSIS:

(a) Draw a free body diagram indicating all forces acting on the piston. Taking upward as the positive y -direction, the sum of the forces acting on the piston in the y -direction must equal zero for static equilibrium of the piston.

$$\uparrow \sum F_y = 0$$

$$p_{\text{Air}} A_{\text{piston}} - p_{\text{atm}} A_{\text{piston}} - m_{\text{piston}} g = 0$$

Solving for the mass of the piston,

$$m_{\text{piston}} = \frac{p_{\text{Air}} A_{\text{piston}} - p_{\text{atm}} A_{\text{piston}}}{g}$$

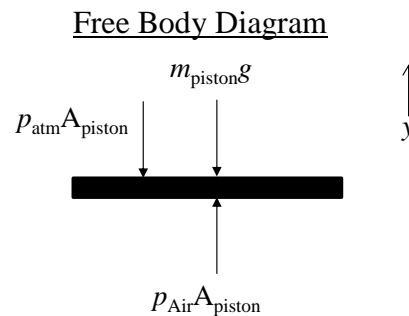

$$m_{\text{piston}} = \frac{(p_{\text{Air}} - p_{\text{atm}})A_{\text{piston}}}{g}$$

The area of the piston is determined from the piston diameter

$$A_{\text{piston}} = \frac{\pi}{4} D^2 = \frac{\pi}{4} (6 \text{ in.})^2 = 28.3 \text{ in.}^2$$

Substituting values and solving for the mass of the piston,

$$m_{\text{piston}} = \frac{\left(16 \frac{\text{lb}}{\text{in.}^2} - 14.7 \frac{\text{lb}}{\text{in.}^2}\right) (28.3 \text{ in.}^2) \left| \frac{32.2 \frac{\text{lb} \cdot \text{ft}}{\text{s}^2}}{1 \text{ lbf}} \right|}{32.2 \frac{\text{ft}}{\text{s}^2}} = \underline{\underline{36.8 \text{ lb}}}$$

(b) Gage pressure of the air is given by Eq. 1.14

$$p(\text{gage}) = p(\text{absolute}) - p_{\text{atm}}(\text{absolute}) = 16.0 \text{ psia} - 14.7 \text{ psia} = \underline{\underline{1.3 \text{ psig}}}$$

1.35 Air is contained in a vertical piston-cylinder assembly such that the piston is in static equilibrium. The atmosphere exerts a pressure of 101 kPa on top of the 0.5-meter-diameter piston. The gage pressure of the air inside the cylinder is 1.2 kPa. The local acceleration of gravity is $g = 9.81 \text{ m/s}^2$. Subsequently, a weight is placed on top of the piston causing the piston to fall until reaching a new static equilibrium position. At this position, the gage pressure of the air inside the cylinder is 2.8 kPa. Determine (a) the mass of the piston, in kg, and (b) the mass of the added weight, in kg.

KNOWN: A piston-cylinder assembly contains air such that the piston is in static equilibrium. Upon addition of a weight, the piston falls until reaching a new position of static equilibrium.

FIND: (a) The mass of the piston, in kg, and (b) the mass of the added weight, in kg.

SCHEMATIC AND GIVEN DATA:

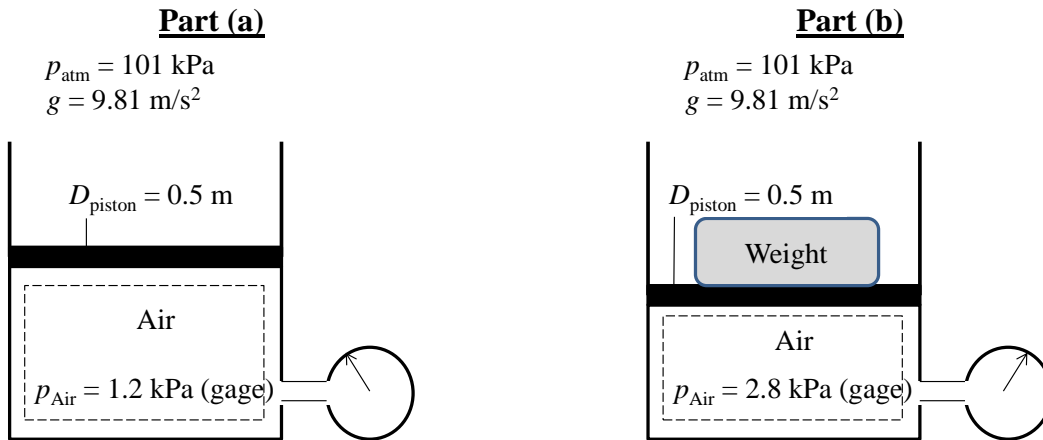

ENGINEERING MODEL:

1. The air is a closed system.
2. The piston is in static equilibrium for both part (a) and part (b).
3. Atmospheric pressure is exerted on the top of the piston.
4. Local gravitational acceleration is 9.81 m/s^2 .

ANALYSIS:

(a) Draw a free body diagram indicating all forces acting on the piston. Taking upward as the positive y -direction, the sum of the forces acting on the piston in the y -direction must equal zero for static equilibrium of the piston.

$$\uparrow \Sigma F_y = 0$$

$$p_{\text{Air}}A_{\text{piston}} - p_{\text{atm}}A_{\text{piston}} - m_{\text{piston}}g = 0$$

Solving for the mass of the piston,

$$m_{\text{piston}} = \frac{p_{\text{Air}}A_{\text{piston}} - p_{\text{atm}}A_{\text{piston}}}{g}$$

$$m_{\text{piston}} = \frac{(p_{\text{Air}} - p_{\text{atm}})A_{\text{piston}}}{g}$$

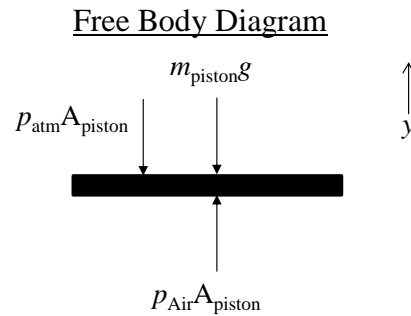

From Eq. 1.14, the quantity in parenthesis is the gage pressure of the air in the cylinder. Rewriting the equation above

$$m_{\text{piston}} = \frac{p_{\text{Air(gage)}}A_{\text{piston}}}{g}$$

The area of the face of the piston is determined using

$$A_{\text{piston}} = \frac{\pi}{4}D^2 = \frac{\pi}{4}(0.5 \text{ m})^2 = 0.196 \text{ m}^2$$

Substituting values and solving for the mass of the piston,

$$m_{\text{piston}} = \frac{(1.2 \text{ kPa})(0.196 \text{ m}^2)}{9.81 \frac{\text{m}}{\text{s}^2}} \left| \frac{1000 \frac{\text{N}}{\text{m}^2}}{1 \text{ kPa}} \right| \left| \frac{1 \frac{\text{kg} \cdot \text{m}}{\text{s}^2}}{1 \text{ N}} \right| = \mathbf{4.7 \text{ kg}}$$

(b) Draw a second free body diagram indicating all forces acting on the piston including the newly added weight expressed as the product of its mass and gravitational acceleration. Taking upward as the positive y -direction, the sum of the forces acting on the piston in the y -direction must equal zero for static equilibrium of the piston.

$$\uparrow \sum F_y = 0$$

$$p_{\text{Air}}A_{\text{piston}} - p_{\text{atm}}A_{\text{piston}} - m_{\text{piston}}g - m_{\text{weight}}g = 0$$

Solving for the mass of the weight,

$$m_{\text{weight}} = \frac{p_{\text{Air}}A_{\text{piston}} - p_{\text{atm}}A_{\text{piston}}}{g} - m_{\text{piston}}$$

$$m_{\text{weight}} = \frac{(p_{\text{Air}} - p_{\text{atm}})A_{\text{piston}}}{g} - m_{\text{piston}}$$

From Eq. 1.14, the quantity in parenthesis is the gage pressure of the air in the cylinder. Rewriting the equation above

$$m_{\text{weight}} = \frac{p_{\text{Air(gage)}}A_{\text{piston}}}{g} - m_{\text{piston}}$$

Substituting values and solving for the mass of the weight,

$$m_{\text{weight}} = \frac{(2.8 \text{ kPa})(0.196 \text{ m}^2)}{9.81 \frac{\text{m}}{\text{s}^2}} \left| \frac{1000 \frac{\text{N}}{\text{m}^2}}{1 \text{ kPa}} \right| \left| \frac{1 \frac{\text{kg} \cdot \text{m}}{\text{s}^2}}{1 \text{ N}} \right| - 4.7 \text{ kg} = \mathbf{51.2 \text{ kg}}$$

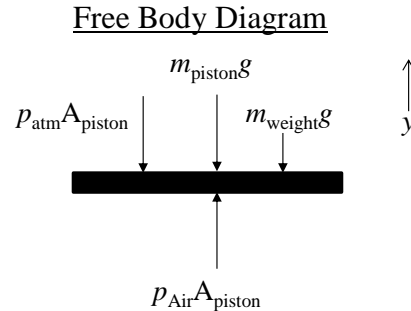

- 1.36** Figure P1.36 shows a tank used to collect rainwater having a diameter of 4 m. As shown in the figure, the depth of the tank varies linearly from 3.5 m at its center to 3 m along the perimeter. The local atmospheric pressure is 1 bar, the acceleration of gravity is $g = 9.8 \text{ m/s}^2$, and the density of the water is 987.1 kg/m^3 . When the tank is filled with water, determine
- The pressure, in kPa, at the bottom center of the tank.
 - The total force, in kN, acting on the bottom of the tank.

KNOWN: Rainwater is collected in a tank that varies linearly from its center to its perimeter.

FIND: (a) the pressure at the bottom center of the tank and (b) the total force acting on the bottom of the tank.

SCHEMATIC AND GIVEN DATA:

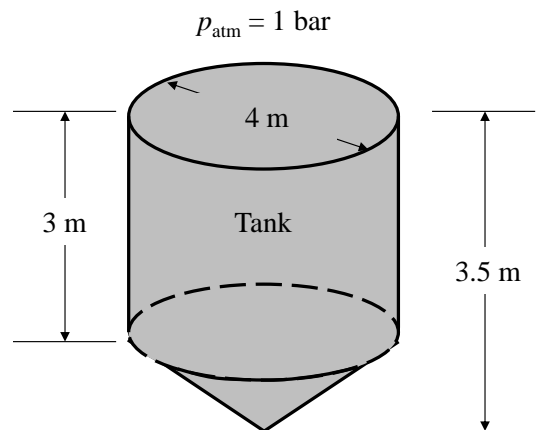

ENGINEERING MODEL:

- Water density is 987.1 kg/m^3 .
- Local atmospheric pressure is 1 bar.
- Local gravitational acceleration is 9.8 m/s^2 .

ANALYSIS:

(a) The depth at the center of the tank is 3.5 m and the corresponding pressure at the center (p_c) in kPa is as follows

$$p_c = p_{\text{atm}} + \rho gh = (1 \text{ bar}) \left| \frac{100 \text{ kPa}}{1 \text{ bar}} \right| + \left(987.1 \frac{\text{kg}}{\text{m}^3} \right) \left(9.8 \frac{\text{m}}{\text{s}^2} \right) (3.5 \text{ m}) \left| \frac{1 \text{ N}}{1 \frac{\text{kg} \cdot \text{m}}{\text{s}^2}} \right| \left| \frac{1 \text{ kPa}}{10^3 \frac{\text{N}}{\text{m}^2}} \right| = \underline{\underline{133.9 \text{ kPa}}}$$

(b) The force acting on the bottom (F_{tot}) of the tank is the sum of the weight of the water plus the force of the atmosphere. The force of the atmosphere (F_{atm}) in kN is

$$F_{\text{atm}} = p_{\text{atm}} \pi \frac{D^2}{4} = (1 \text{ bar}) \left| \frac{10^5 \frac{\text{N}}{\text{m}^2}}{1 \text{ bar}} \right| \pi \frac{(4 \text{ m})^2}{4} \left| \frac{1 \text{ kN}}{10^3 \text{ N}} \right| = 12.6 \times 10^2 \text{ kN}$$

The weight of the water is given by

$$\text{weight} = m_w g = \rho V g \quad (1)$$

where ρ is the density of the water and g is the acceleration of gravity which were both given. The total volume of the water in the tank (V) is equal to the volume of a cylinder having a diameter, $D = 4$ m, and a length, $L = 3$ m, plus the volume of a cone having $D = 4$ m and a height, $H = 0.5$ m. Thus,

$$V = V_{\text{cyl}} + V_{\text{cone}} = \pi L \left(\frac{D^2}{4} \right) + \left(\frac{1}{3} \right) \pi H \left(\frac{D^2}{4} \right) = \pi \left(\frac{D^2}{4} \right) \left(L + \frac{H}{3} \right)$$

$$V = \pi \left(\frac{(4 \text{ m})^2}{4} \right) \left(3 + \frac{0.5}{3} \right) \text{ m} = 39.8 \text{ m}^3$$

Substituting values into Eq. (1)

$$\rho V g = \left(987.1 \frac{\text{kg}}{\text{m}^3} \right) \left(9.8 \frac{\text{m}}{\text{s}^2} \right) (39.8 \text{ m}^3) \left| \frac{1 \text{ N}}{1 \frac{\text{kg} \cdot \text{m}}{\text{s}^2}} \right| \left| \frac{1 \text{ kN}}{10^3 \text{ N}} \right| = 3.85 \times 10^2 \text{ kN}$$

Finally, the total force acting on the bottom of the tank is

$$F_{\text{tot}} = \text{weight} + F_{\text{atm}} = 3.85 \times 10^2 \text{ kN} + 12.6 \times 10^2 \text{ kN} = \underline{\underline{16.5 \times 10^2 \text{ kN}}}$$

1.37 If the water pressure at the base of the water tower shown in Fig. P1.37 is 4.15 bar, determine the pressure of the air trapped above the water level, in bar. The density of the water is 10^3 kg/m^3 . And $g = 9.81 \text{ m/s}^2$.

KNOWN: Air is trapped above a column of water in a water tower.

FIND: the pressure of the air trapped above the water level.

SCHEMATIC AND GIVEN DATA:

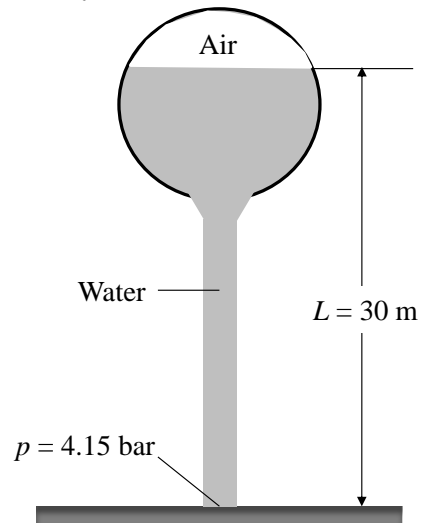

ENGINEERING MODEL:

1. Water density is 10^3 kg/m^3 .
2. Local gravitational acceleration is 9.81 m/s^2 .

ANALYSIS: Ignoring the vertical variation in pressure of the air trapped above the water level,

$$p = p_{\text{air}} + \rho g L$$

↑
pressure at the base

$$p_{\text{air}} = p - \rho g L$$

$$p_{\text{air}} = (4.15 \text{ bar}) - \left(10^3 \frac{\text{kg}}{\text{m}^3}\right) \left(9.81 \frac{\text{m}}{\text{s}^2}\right) (30 \text{ m}) \left| \frac{1 \text{ N}}{1 \frac{\text{kg} \cdot \text{m}}{\text{s}^2}} \right| \left| \frac{1 \text{ bar}}{10^5 \frac{\text{N}}{\text{m}^2}} \right| = \underline{\underline{1.21 \text{ bar}}}$$

1.38 As shown in Figure P1.38, an inclined manometer is used to measure the pressure of the gas within the reservoir. (a) Using data on the figure, determine the gas pressure, in lbf/in.² (b) Express the pressure as a gage or a vacuum pressure, as appropriate, in lbf/in.² (c) What advantage does an inclined manometer have over the U-tube manometer shown in Figure 1.7?

KNOWN: A gas contained in a reservoir with inclined manometer attached.

FIND: (a) Pressure of gas within the reservoir, in lbf/in.² (b) Pressure expressed as gage or vacuum pressure, as appropriate, in lbf/in.² (c) Advantage of inclined manometer over the U-tube manometer.

SCHEMATIC AND GIVEN DATA:

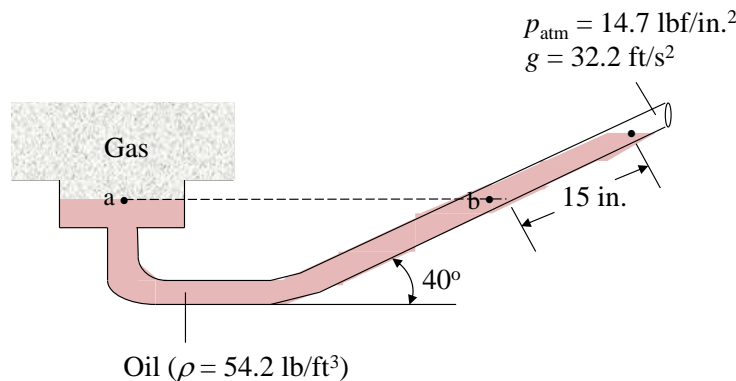

ENGINEERING MODEL:

1. The gas is a closed system.
2. Atmospheric pressure is exerted at the open end of the manometer.
3. The manometer fluid is oil with a density of 54.2 lb/ft^3 .

ANALYSIS:

(a) Applying Eq. 1.11

$$p_{\text{gas}} = p_{\text{atm}} + \rho g L$$

where p_{atm} is the local atmospheric pressure, ρ is the density of the manometer fluid (oil), g is the acceleration due to gravity, and L is the vertical difference in liquid levels. Since level a is the same as level b, applying trigonometry to determine the vertical difference in liquid levels between level b and the liquid level at the free surface with the atmosphere yields

$$p_{\text{gas}} = p_{\text{atm}} + \rho g L (\sin 40^\circ)$$

Substituting values

$$p_{gas} = 14.7 \frac{\text{lbf}}{\text{in.}^2} + \left(54.2 \frac{\text{lb}}{\text{ft}} \right) \left(32.2 \frac{\text{ft}}{\text{s}^2} \right) (15 \text{ in.}) (\sin 40^\circ) \left| \frac{1 \text{ lbf}}{32.2 \frac{\text{lbm} \cdot \text{ft}}{\text{s}^2}} \right| \left| \frac{1 \text{ ft}^3}{1728 \text{ in.}^3} \right| = \underline{\underline{15.0 \text{ lbf/in.}^2}}$$

(b) Since the pressure of the gas is greater than atmospheric pressure, gage pressure is given by Eq. 1.14

$$p(\text{gage}) = p(\text{absolute}) - p_{\text{atm}}(\text{absolute}) = 15.0 \text{ psia} - 14.7 \text{ psia} = \underline{\underline{0.3 \text{ psig}}}$$

(c) The advantage of the inclined manometer is its easier readability since the surface of the liquid is wider than with a same diameter U-tube manometer. The scale on the inclined manometer is much more precise since more graduations are possible compared with the U-tube manometer.

Substituting values for pressures and specific volume yields

$$v_2 = \left(0.5 \frac{\text{m}^3}{\text{kg}} \right) \left(\frac{250 \text{ kPa}}{100 \text{ kPa}} \right)^{\frac{1}{0.5}} = \underline{\underline{3.125 \text{ m}^3/\text{kg}}}$$

The volume of the system increased while pressure decreased during the process.

A plot of the process on a pressure versus specific volume graph is as follows:

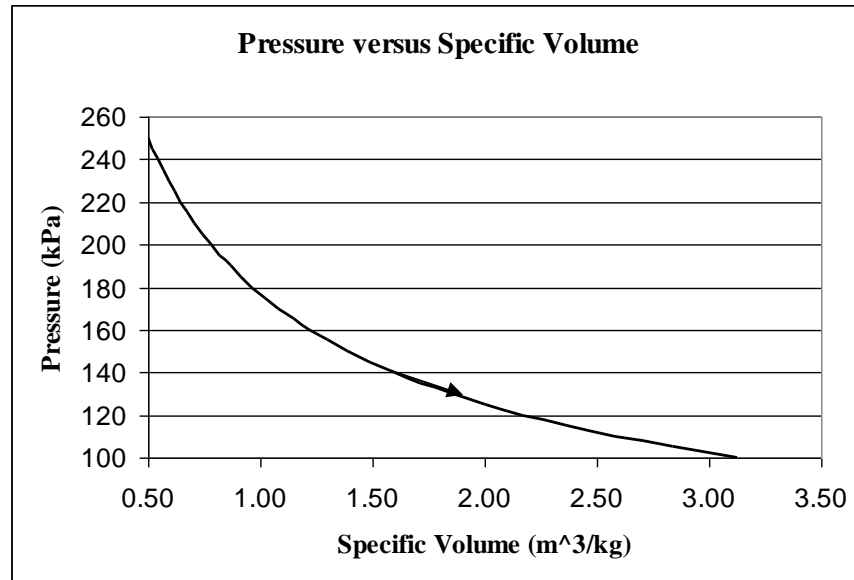

1.39 Figure P1.39 shows a spherical buoy, having a diameter of 1.5 m and weighing 8500 N, anchored to the floor of a lake by a cable. Determine the force exerted by the cable, in N. The density of the lake water is 10^3 kg/m^3 and $g = 9.81 \text{ m/s}^2$.

KNOWN: A buoy with known diameter and weight is anchored to the floor of a lake by a cable.

FIND: the force exerted by the cable.

SCHEMATIC AND GIVEN DATA:

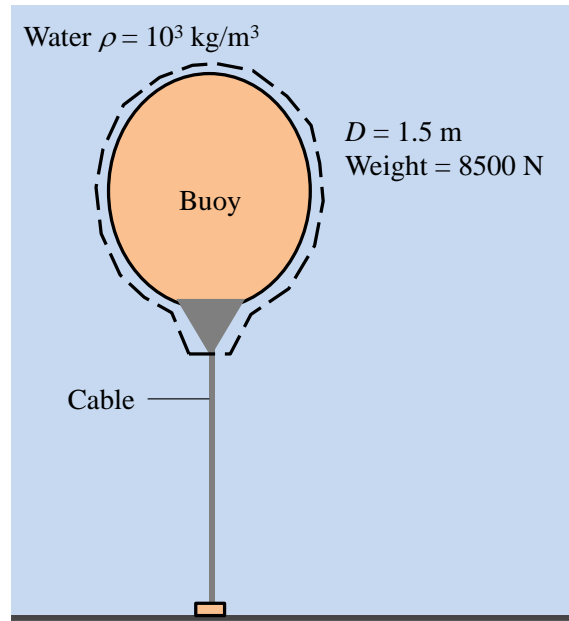

ENGINEERING MODEL:

1. The buoy is completely submerged in the water.
2. The acceleration of gravity is 9.81 m/s^2 .

ANALYSIS: The resultant pressure force acting on the system denoted by the dashed line is the buoyant force, F_B , acting vertically upward with a magnitude equal to the weight of the displaced water. See Sec. 1.6.2 for discussion. Also acting on the system, vertically downward, are the weight of the system and the force exerted by the cable. In sum,

$$F_B = \text{Weight} + F_{\text{cable}}$$

$$F_{\text{cable}} = F_B - \text{Weight} = (\rho V)g - \text{Weight}$$

with $V = \pi D^3/6$ for a sphere,

$$F_{\text{cable}} = \rho \left(\frac{\pi D^3}{6} \right) g - \text{Weight}$$

Calculating,

$$F_{\text{cable}} = \left(10^3 \frac{\text{kg}}{\text{m}^3} \right) \left(\frac{\pi (1.5 \text{ m})^3}{6} \right) \left(9.81 \frac{\text{m}}{\text{s}^2} \right) \left| \frac{1 \text{ N}}{1 \frac{\text{kg} \cdot \text{m}}{\text{s}^2}} \right| - 8500 \text{ N} = \underline{\underline{8836 \text{ N}}}$$

1.40 Because of a break in a buried oil storage tank, ground water has leaked into the tank to the depth shown in Fig. P1.40. Determine the pressure at the oil-water interface and at the bottom of the tank, each in lbf/in.^2 (gage). The densities of the water and oil are, respectively, 62 and 55, each in lb/ft^3 . Let $g = 32.2 \text{ ft/s}^2$.

KNOWN: Ground water has leaked into a buried oil storage tank. Densities of the water and oil are known.

FIND: the pressure at the oil-water interface and at the bottom of the tank.

SCHEMATIC AND GIVEN DATA:

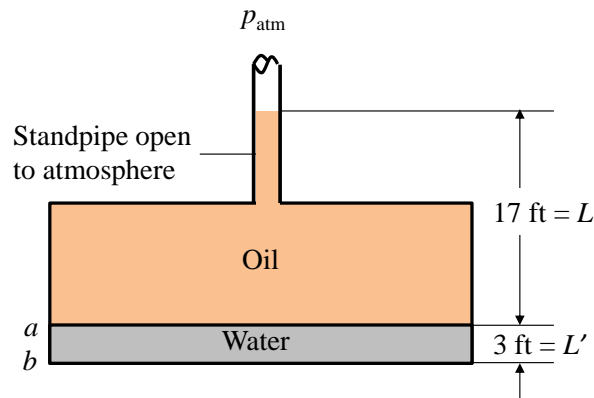

ENGINEERING MODEL:

1. The acceleration of gravity is 32.2 ft/s^2 .

ANALYSIS: With Eq. 1.11, the pressure at the oil-water interface is,

$$p_a = p_{\text{atm}} + \rho_o g L$$

Expressed as a gage pressure, this is

$$p_a (\text{gage}) = [p_a - p_{\text{atm}}] = \rho_o g L$$

Calculating,

$$p_a (\text{gage}) = \left(55 \frac{\text{lb}}{\text{ft}^3} \right) \left(32.2 \frac{\text{ft}}{\text{s}^2} \right) (17 \text{ ft}) \left| \frac{1 \text{ lbf}}{32.2 \frac{\text{lb} \cdot \text{ft}}{\text{s}^2}} \right| \left| \frac{1 \text{ ft}^2}{144 \text{ in}^2} \right| = \underline{\underline{6.49 \text{ lbf/in}^2 (\text{gage})}}$$

The pressure at the bottom of the tank is

$$p_b = p_a + \rho_w g L' = [p_a - p_{\text{atm}}] + \rho_w g L'$$

$$p_b \text{ (gage)} = [p_b - p_{\text{atm}}] = \rho_o g L + \rho_w g L'$$

$$p_b \text{ (gage)} = 6.49 \frac{\text{lbf}}{\text{in}^2} + \left(62 \frac{\text{lb}}{\text{ft}^3} \right) \left(32.2 \frac{\text{ft}}{\text{s}^2} \right) (3 \text{ ft}) \left| \frac{1 \text{ lbf}}{32.2 \frac{\text{lb} \cdot \text{ft}}{\text{s}^2}} \right| \left| \frac{1 \text{ ft}^2}{144 \text{ in}^2} \right| = \underline{\underline{7.78 \text{ lbf/in}^2 \text{ (gage)}}}$$

1.41 Figure P1.41 shows a closed tank holding air and oil to which is connected a U-tube mercury manometer and a pressure gage. Determine the reading of the pressure gage, in lbf/in.^2 (gage). The densities of the oil and mercury are, 55 and 845, respectively, each in lb/ft^3 . Let $g = 32.2 \text{ ft/s}^2$.

KNOWN: Air and oil are in a closed tank to which a U-tube manometer and a pressure gage are connected. Densities of the oil and mercury are known.

FIND: the reading of the pressure gage.

SCHEMATIC AND GIVEN DATA:

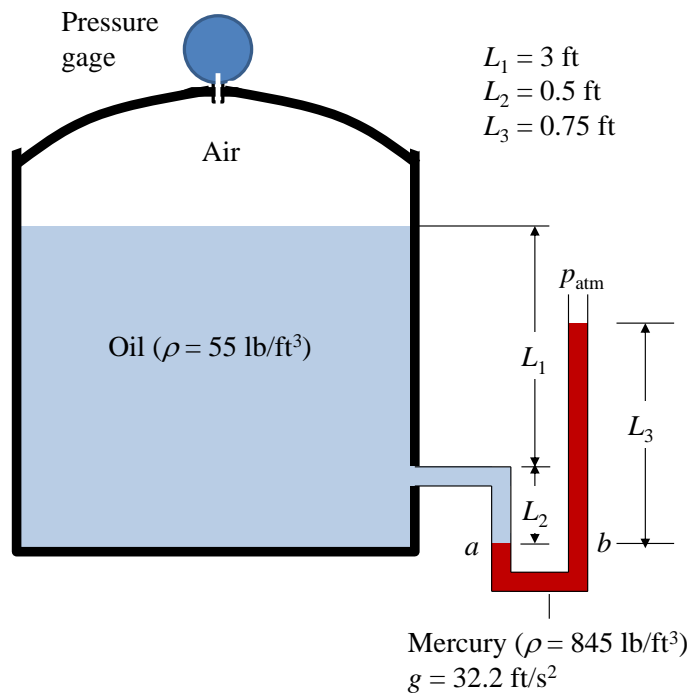

ENGINEERING MODEL:

1. The acceleration of gravity is 32.2 ft/s^2 .

ANALYSIS: Ignoring the vertical pressure variation of the air trapped above the oil, the gage reads

$$p_{\text{gage}} = p_{\text{air}} - p_{\text{atm}} \quad (1)$$

We also have

$$p_a = p_{\text{air}} + \rho_o g(L_1 + L_2) \quad (2)$$

and

$$p_b = p_{\text{atm}} + \rho_m g L_3 \quad (3)$$

Then, since $p_a = p_b$, Eqs. (2) and (3) give

$$p_{\text{air}} + \rho_o g(L_1 + L_2) = p_{\text{atm}} + \rho_m g L_3$$

$$p_{\text{air}} - p_{\text{atm}} = \rho_m g L_3 - \rho_o g (L_1 + L_2)$$

$$p_{\text{gage}} = [\rho_m L_3 - \rho_o (L_1 + L_2)] g$$

Calculating,

$$p_{\text{gage}} = \left[\left(845 \frac{\text{lb}}{\text{ft}^3} \right) (0.75 \text{ ft}) - \left(55 \frac{\text{lb}}{\text{ft}^3} \right) (3.5 \text{ ft}) \right] \left(32.2 \frac{\text{ft}}{\text{s}^2} \right) \left| \frac{1 \text{ lbf}}{32.2 \frac{\text{lb} \cdot \text{ft}}{\text{s}^2}} \right| \left| \frac{1 \text{ ft}^2}{144 \text{ in}^2} \right| = \underline{\underline{\mathbf{3.06 \text{ lbf/in}^2 \text{ (gage)}}}}$$

1.42 The 30-year average temperature in Toronto, Canada, during summer is 19.5°C and during winter is -4.9°C . What are the equivalent average summer and winter temperatures in $^{\circ}\text{F}$ and $^{\circ}\text{R}$?

KNOWN: Average summer and winter temperatures in Toronto, Canada.

FIND: Determine average summer and winter temperatures in $^{\circ}\text{F}$ and $^{\circ}\text{R}$.

SCHEMATIC AND GIVEN DATA:

$$T_{\text{summer}} = 19.5^{\circ}\text{C}$$

$$T_{\text{winter}} = -4.9^{\circ}\text{C}$$

ANALYSIS:

First convert temperatures from $^{\circ}\text{C}$ to K by rearranging Eq. 1.17 to solve for temperature in K

$$T(^{\circ}\text{C}) = T(\text{K}) - 273.15 \quad \rightarrow \quad T(\text{K}) = T(^{\circ}\text{C}) + 273.15$$

For summer: $T_{\text{summer}}(\text{K}) = 19.5^{\circ}\text{C} + 273.15 = 292.65 \text{ K}$

For winter: $T_{\text{winter}}(\text{K}) = -4.9^{\circ}\text{C} + 273.15 = 268.25 \text{ K}$

Next apply Eq. 1.16 to solve for temperatures in $^{\circ}\text{R}$

$$T(^{\circ}\text{R}) = 1.8T(\text{K})$$

For summer: $T_{\text{summer}}(^{\circ}\text{R}) = (1.8)(292.65 \text{ K}) = \underline{\underline{526.77^{\circ}\text{R}}}$

For winter: $T_{\text{winter}}(^{\circ}\text{R}) = (1.8)(268.25 \text{ K}) = \underline{\underline{482.85^{\circ}\text{R}}}$

Finally, apply Eq. 1.18 to solve for temperatures in $^{\circ}\text{F}$

$$T(^{\circ}\text{F}) = T(^{\circ}\text{R}) - 459.67$$

For summer: $T_{\text{summer}}(^{\circ}\text{F}) = 526.77^{\circ}\text{R} - 459.67 = \underline{\underline{67.10^{\circ}\text{F}}}$

For winter: $T_{\text{winter}}(^{\circ}\text{F}) = 482.85^{\circ}\text{R} - 459.67 = \underline{\underline{23.18^{\circ}\text{F}}}$

1.43 Water in a swimming pool has a temperature of 24°C . Express this temperature in K, $^{\circ}\text{F}$, and $^{\circ}\text{R}$.

KNOWN: Water is at a specified temperature in $^{\circ}\text{C}$.

FIND: Equivalent temperature in K, $^{\circ}\text{F}$, and $^{\circ}\text{R}$.

SCHEMATIC AND GIVEN DATA:

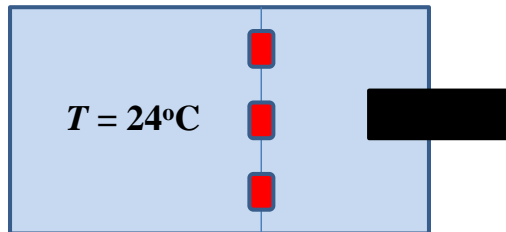

ANALYSIS:

First convert temperature from $^{\circ}\text{C}$ to K by rearranging Eq. 1.17 to solve for temperature in K

$$T(^{\circ}\text{C}) = T(\text{K}) - 273.15 \quad \rightarrow \quad T(\text{K}) = T(^{\circ}\text{C}) + 273.15$$

$$T_{\text{water}} (\text{K}) = 24^{\circ}\text{C} + 273.15 = \mathbf{297.15 \text{ K}}$$

Next apply Eq. 1.16 to solve for temperature in $^{\circ}\text{R}$

$$T(^{\circ}\text{R}) = 1.8T(\text{K})$$

$$T_{\text{water}} (^{\circ}\text{R}) = (1.8)(297.15 \text{ K}) = \mathbf{534.87 ^{\circ}\text{R}}$$

Finally, apply Eq. 1.18 to solve for temperatures in $^{\circ}\text{F}$

$$T(^{\circ}\text{F}) = T(^{\circ}\text{R}) - 459.67$$

$$T_{\text{water}} (^{\circ}\text{F}) = 534.87 ^{\circ}\text{R} - 459.67 = \mathbf{75.2^{\circ}\text{F}}$$

1.44 A cake recipe specifies an oven temperature of 350°F. Express this temperature in °R, K, and °C.

KNOWN: Oven temperature is specified in °F.

FIND: Equivalent temperature in °R, K, and °C.

SCHEMATIC AND GIVEN DATA:

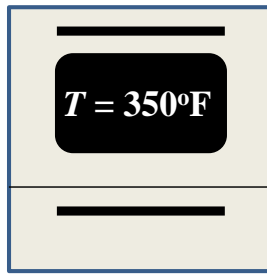

ANALYSIS:

First convert temperature from °F to °R using Eq. 1.18 to solve for temperature in °R

$$T(^{\circ}\text{F}) = T(^{\circ}\text{R}) - 459.67 \rightarrow T(^{\circ}\text{R}) = T(^{\circ}\text{F}) + 459.67$$

$$T_{\text{oven}} (^{\circ}\text{R}) = 350^{\circ}\text{F} + 459.67 = \mathbf{809.67^{\circ}\text{R}}$$

Next apply Eq. 1.16 to solve for temperature in K

$$T(^{\circ}\text{R}) = 1.8T(\text{K}) \rightarrow T(\text{K}) = T(^{\circ}\text{R})/1.8$$

$$T_{\text{oven}} (\text{K}) = 809.67^{\circ}\text{R}/1.8 = \mathbf{449.82 \text{ K}}$$

Finally, apply Eq. 1.17 to solve for temperature in °C

$$T(^{\circ}\text{C}) = T(\text{K}) - 273.15$$

$$T_{\text{oven}} (^{\circ}\text{C}) = 449.82 \text{ K} - 273.15 = \mathbf{176.67^{\circ}\text{C}}$$

1.45 Place the following temperatures in order from highest to lowest in units of K and °R: $T_A = 30^\circ\text{C}$, $T_B = 30^\circ\text{F}$, $T_C = 30^\circ\text{R}$, and $T_D = 30\text{ K}$.

KNOWN: Specified temperatures of $T_A = 30^\circ\text{C}$, $T_B = 30^\circ\text{F}$, $T_C = 30^\circ\text{R}$, and $T_D = 30\text{ K}$.

FIND: Order the temperatures from highest to lowest in units of K and °R.

SCHEMATIC AND GIVEN DATA:

Temperatures

$$T_A = 30^\circ\text{C}$$

$$T_B = 30^\circ\text{F}$$

$$T_C = 30^\circ\text{R}$$

$$T_D = 30\text{ K}$$

ANALYSIS:

Convert temperature A from °C to K using Eq. 1.17

$$T(^{\circ}\text{C}) = T(\text{K}) - 273.15 \quad \rightarrow \quad T(\text{K}) = T(^{\circ}\text{C}) + 273.15$$

$$T_A(\text{K}) = 30^\circ\text{C} + 273.15 = \mathbf{303.15\text{ K}}$$

Next apply Eq. 1.16 to solve for temperature A in °R

$$T(^{\circ}\text{R}) = 1.8T(\text{K})$$

$$T_A(^{\circ}\text{R}) = (1.8)(303.15\text{ K}) = \mathbf{545.67^{\circ}\text{R}}$$

Convert temperature B from °F to °R by rearranging Eq. 1.18

$$T(^{\circ}\text{F}) = T(^{\circ}\text{R}) - 459.67 \quad \rightarrow \quad T(^{\circ}\text{R}) = T(^{\circ}\text{F}) + 459.67$$

$$T_B(^{\circ}\text{R}) = 30^{\circ}\text{F} + 459.67 = \mathbf{489.67^{\circ}\text{R}}$$

Next rearrange Eq. 1.16 to solve for temperature B in K

$$T(^{\circ}\text{R}) = 1.8T(\text{K}) \quad \rightarrow \quad T(\text{K}) = T(^{\circ}\text{R})/1.8$$

$$T_B(\text{K}) = 489.67^{\circ}\text{R}/1.8 = \mathbf{272.04\text{ K}}$$

Using Eq. 1.16 to solve for temperature C in K

$$T_C(\text{K}) = 30^{\circ}\text{R}/1.8 = \mathbf{16.67\text{ K}}$$

Using Eq. 1.16 to solve for temperature D in °R

$$T_D(^{\circ}\text{R}) = (1.8)(30 \text{ K}) = \mathbf{54^{\circ}\text{R}}$$

Temperatures ordered from highest to lowest are:

	Temperature (K)	Temperature ($^{\circ}\text{R}$)
Highest Temperature	$T_A = 303.15 \text{ K}$	$T_A = 545.67^{\circ}\text{R}$
↓	$T_B = 272.04 \text{ K}$	$T_B = 489.67^{\circ}\text{R}$
↓	$T_D = 30 \text{ K}$	$T_D = 54^{\circ}\text{R}$
Lowest Temperature	$T_C = 16.67 \text{ K}$	$T_C = 30^{\circ}\text{R}$

In this case, the order of temperatures from highest to lowest is the same for K and $^{\circ}\text{R}$.

1.46 Figure 1.46 shows a system consisting of a cylindrical copper rod insulated on its lateral surface while its ends are in contact with hot and cold walls at temperatures 1000°R and 500°R , respectively.

- (a) Sketch the variation of temperature with position through the rod, x .
(b) Is the rod in equilibrium? Explain.

KNOWN: The ends of a copper rod insulated on its lateral surface are in contact with hot and cold walls.

FIND: (a) Sketch the variation of temperature with position through the rod, x , and (b) Indicate whether the rod is in equilibrium and explain.

SCHEMATIC AND GIVEN DATA:

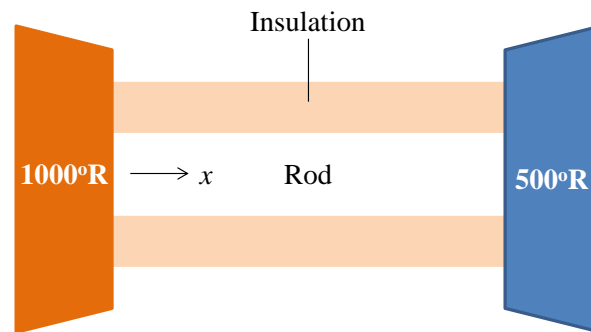

ANALYSIS:

- (a) The variation of temperature with position through the rod is

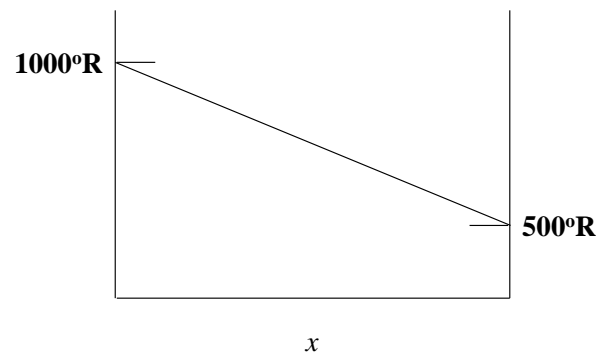

- (b) Apply the test for equilibrium given in Sec. 1.3.4 -- namely, think of isolating the system and watching for changes in observable properties. In this instance, the rod is the system and the relevant observable is its temperature. If the rod is also insulated on its ends, its temperature will eventually become uniform throughout, indicating that the rod was not in equilibrium initially.

1.47 The normal temperature of the human body is $98.6^{\circ}\text{F} \pm 1^{\circ}\text{F}$. Determine the normal temperature range, in $^{\circ}\text{C}$, for the human body.

KNOWN: The normal temperature range of the human body is given in $^{\circ}\text{F}$.

FIND: Determine the normal temperature range of the human body in $^{\circ}\text{C}$.

SCHEMATIC AND GIVEN DATA:

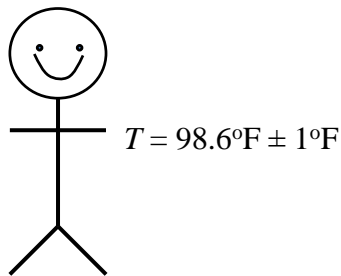

ANALYSIS:

Convert body temperature from $^{\circ}\text{F}$ to $^{\circ}\text{R}$ by rearranging Eq. 1.18

$$T(^{\circ}\text{F}) = T(^{\circ}\text{R}) - 459.67 \quad \rightarrow \quad T(^{\circ}\text{R}) = T(^{\circ}\text{F}) + 459.67$$

$$T(^{\circ}\text{R}) = 98.6^{\circ}\text{F} + 459.67 = 558.27^{\circ}\text{R}$$

Since temperature differences on the Fahrenheit scale and the Rankine scale are identical, the body temperature range in $^{\circ}\text{R}$ is

$$T(^{\circ}\text{R}) = 558.27^{\circ}\text{R} \pm 1^{\circ}\text{R}$$

Next rearrange Eq. 1.16 to solve for body temperature and its range in K

$$T(^{\circ}\text{R}) = 1.8T(\text{K}) \quad \rightarrow \quad T(\text{K}) = T(^{\circ}\text{R})/1.8$$

$$T(\text{K}) = 558.27^{\circ}\text{R}/1.8 = 310.15 \text{ K} \quad \text{and} \quad T(\text{K}) = 1^{\circ}\text{R}/1.8 = 0.56 \text{ K}$$

Convert body temperature from K to $^{\circ}\text{C}$ by using Eq. 1.17.

$$T(^{\circ}\text{C}) = T(\text{K}) - 273.15$$

$$T(^{\circ}\text{C}) = 310.15 \text{ K} - 273.15 = 37^{\circ}\text{C}$$

Since temperature differences on the Celsius scale and the Kelvin scale are identical, the body temperature range in $^{\circ}\text{C}$ is

$$\underline{\underline{T(^{\circ}\text{C}) = 37^{\circ}\text{C} \pm 0.56^{\circ}\text{C}}}$$

1.48 Air temperature rises from a morning low of 42°F to an afternoon high of 70°F.

- (a) Express these temperatures in °R, K, and °C.
- (b) Determine the temperature *change* in °F, °R, K, and °C from morning low to afternoon high.
- (c) What conclusion do you draw about temperature *change* for °F and °R scales?
- (d) What conclusion do you draw about temperature *change* for °C and K scales?

KNOWN: Morning low temperature and afternoon high temperature, both in °F.

FIND: (a) Express these temperatures in °R, K, and °C, (b) temperature *change* in °F, °R, K, and °C from morning low to afternoon high, (c) conclusion about temperature *change* for °F and °R scales, (d) conclusion about temperature *change* for °C and K scales.

SCHEMATIC AND GIVEN DATA:

$$T_{\text{low}} = 42^{\circ}\text{F}$$

$$T_{\text{high}} = 70^{\circ}\text{F}$$

ANALYSIS:

(a) First convert temperatures from °F to °R using Eq. 1.18 to solve for temperatures in °R

$$T(^{\circ}\text{F}) = T(^{\circ}\text{R}) - 459.67 \rightarrow T(^{\circ}\text{R}) = T(^{\circ}\text{F}) + 459.67$$

$$T_{\text{low}} (^{\circ}\text{R}) = 42^{\circ}\text{F} + 459.67 = \mathbf{501.67^{\circ}\text{R}}$$

$$T_{\text{high}} (^{\circ}\text{R}) = 70^{\circ}\text{F} + 459.67 = \mathbf{529.67^{\circ}\text{R}}$$

Next apply Eq. 1.16 to solve for temperature in K

$$T(^{\circ}\text{R}) = 1.8T(\text{K}) \rightarrow T(\text{K}) = T(^{\circ}\text{R})/1.8$$

$$T_{\text{low}} (\text{K}) = 501.67^{\circ}\text{R}/1.8 = \mathbf{278.71 \text{ K}}$$

$$T_{\text{high}} (\text{K}) = 529.67^{\circ}\text{R}/1.8 = \mathbf{294.26 \text{ K}}$$

Finally, apply Eq. 1.17 to solve for temperature in °C

$$T(^{\circ}\text{C}) = T(\text{K}) - 273.15$$

$$T_{\text{low}} (^{\circ}\text{C}) = 278.71 \text{ K} - 273.15 = \mathbf{5.56^{\circ}\text{C}}$$

$$T_{\text{high}} (^{\circ}\text{C}) = 294.26 \text{ K} - 273.15 = \mathbf{21.11^{\circ}\text{C}}$$

(b) Temperature change, ΔT , is $T_{\text{high}} - T_{\text{low}}$. Calculating the differences yields

$$\Delta T(^{\circ}\text{F}) = 70^{\circ}\text{F} - 42^{\circ}\text{F} = \mathbf{28^{\circ}\text{F}}$$

$$\Delta T(^{\circ}\text{R}) = 529.67^{\circ}\text{R} - 501.67^{\circ}\text{R} = \mathbf{28^{\circ}\text{R}}$$

$$\Delta T(\text{K}) = 294.26 \text{ K} - 278.71 \text{ K} = \mathbf{15.55 \text{ K}}$$

$$\Delta T(^{\circ}\text{C}) = 21.11 ^{\circ}\text{C} - 5.56 ^{\circ}\text{C} = \mathbf{15.55^{\circ}\text{C}}$$

(c) For $^{\circ}\text{F}$ and $^{\circ}\text{R}$ scales, the temperature *change* is the same since a Rankine degree and a Fahrenheit degree are the same temperature unit.

(d) For $^{\circ}\text{C}$ and K scales, the temperature *change* is the same since a Kelvin degree and a Celsius degree are the same temperature unit.

1.49 Left for independent study using the Internet.