

PROBLEM 1.1

KNOWN: Temperature distribution in wall of Example 1.1.

FIND: Heat fluxes and heat rates at $x = 0$ and $x = L$.

SCHEMATIC:

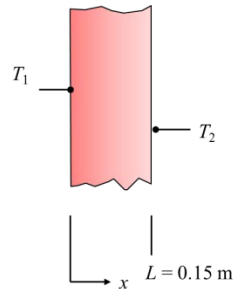

ASSUMPTIONS: (1) One-dimensional conduction through the wall, (2) constant thermal conductivity, (3) no internal thermal energy generation within the wall.

PROPERTIES: Thermal conductivity of wall (given): $k = 1.7 \text{ W/m} \cdot \text{K}$.

ANALYSIS: The heat flux in the wall is by conduction and is described by Fourier's law,

$$q_x'' = -k \frac{dT}{dx} \quad (1)$$

Since the temperature distribution is $T(x) = a + bx$, the temperature gradient is

$$\frac{dT}{dx} = b \quad (2)$$

Hence, the heat flux is constant throughout the wall, and is

$$q_x'' = -k \frac{dT}{dx} = -kb = -1.7 \text{ W/m} \cdot \text{K} \times (-1000 \text{ K/m}) = 1700 \text{ W/m}^2 \quad <$$

Since the cross-sectional area through which heat is conducted is constant, the heat rate is constant and is

$$q_x = q_x'' \times (W \times H) = 1700 \text{ W/m}^2 \times (1.2 \text{ m} \times 0.5 \text{ m}) = 1020 \text{ W} \quad <$$

Because the heat rate into the wall is equal to the heat rate out of the wall, steady-state conditions exist. <

COMMENTS: (1) If the heat rates were not equal, the internal energy of the wall would be changing with time. (2) The temperatures of the wall surfaces are $T_1 = 1400 \text{ K}$ and $T_2 = 1250 \text{ K}$.

PROBLEM 1.2

KNOWN: Thermal conductivity, thickness and temperature difference across a sheet of rigid extruded insulation.

FIND: (a) The heat flux through a 3 m × 3 m sheet of the insulation, (b) the heat rate through the sheet, and (c) the thermal conduction resistance of the sheet.

SCHEMATIC:

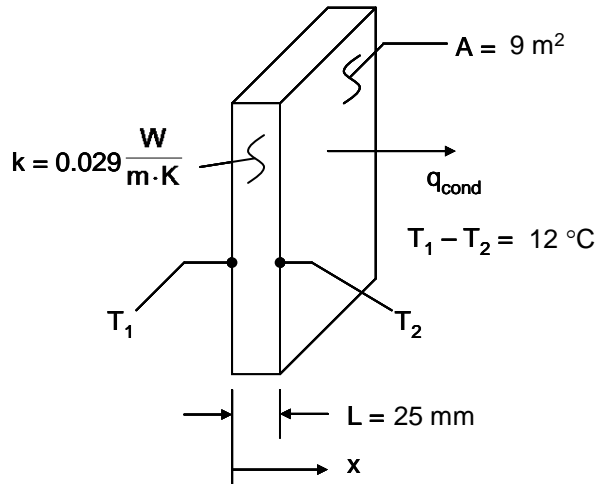

ASSUMPTIONS: (1) One-dimensional conduction in the x-direction, (2) Steady-state conditions, (3) Constant properties.

ANALYSIS: (a) From Equation 1.2 the heat flux is

$$q_x'' = -k \frac{dT}{dx} = k \frac{T_1 - T_2}{L} = 0.029 \frac{\text{W}}{\text{m} \cdot \text{K}} \times \frac{12 \text{ K}}{0.025 \text{ m}} = 13.9 \frac{\text{W}}{\text{m}^2} \quad <$$

(b) The heat rate is

$$q_x = q_x'' \cdot A = 13.9 \frac{\text{W}}{\text{m}^2} \times 9 \text{ m}^2 = 125 \text{ W} \quad <$$

(c) From Eq. 1.11, the thermal resistance is

$$R_{t,\text{cond}} = \Delta T / q_x = 12 \text{ K} / 125 \text{ W} = 0.096 \text{ K/W} \quad <$$

COMMENTS: (1) Be sure to keep in mind the important distinction between the heat flux (W/m^2) and the heat rate (W). (2) The direction of heat flow is from hot to cold. (3) Note that a temperature *difference* may be expressed in kelvins or degrees Celsius. (4) The conduction thermal resistance for a plane wall could equivalently be calculated from $R_{t,\text{cond}} = L/kA$.

PROBLEM 1.3

KNOWN: Thickness and thermal conductivity of a wall. Heat flux applied to one face and temperatures of both surfaces.

FIND: Whether steady-state conditions exist.

SCHEMATIC:

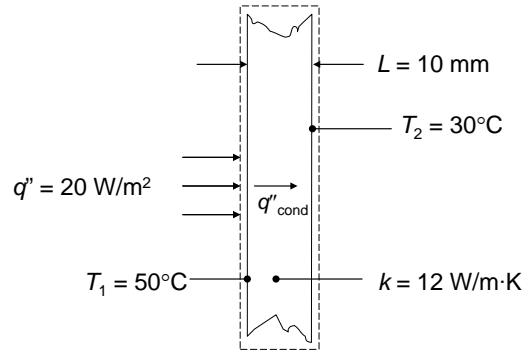

ASSUMPTIONS: (1) One-dimensional conduction, (2) Constant properties, (3) No internal energy generation.

ANALYSIS: Under steady-state conditions an energy balance on the control volume shown is

$$q''_{\text{in}} = q''_{\text{out}} = q''_{\text{cond}} = k(T_1 - T_2)/L = 12 \text{ W/m}\cdot\text{K}(50^\circ\text{C} - 30^\circ\text{C})/0.01 \text{ m} = 24,000 \text{ W/m}^2$$

Since the heat flux in at the left face is only 20 W/m^2 , the conditions are not steady state. <

COMMENTS: If the same heat flux is maintained until steady-state conditions are reached, the steady-state temperature difference across the wall will be

$$\Delta T = q''L/k = 20 \text{ W/m}^2 \times 0.01 \text{ m}/12 \text{ W/m}\cdot\text{K} = 0.0167 \text{ K}$$

which is much smaller than the specified temperature difference of 20°C .

PROBLEM 1.4

KNOWN: Inner surface temperature and thermal conductivity of a concrete wall.

FIND: Heat loss by conduction through the wall as a function of outer surface temperatures ranging from -15 to 38°C .

SCHEMATIC:

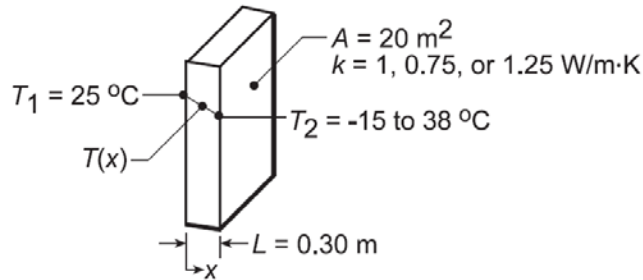

ASSUMPTIONS: (1) One-dimensional conduction in the x -direction, (2) Steady-state conditions, (3) Constant properties.

ANALYSIS: From Fourier's law, if q_x'' and k are each constant it is evident that the gradient, $dT/dx = -q_x''/k$, is a constant, and hence the temperature distribution is linear. The heat flux must be constant under one-dimensional, steady-state conditions; and k is approximately constant if it depends only weakly on temperature. The heat flux and heat rate when the outside wall temperature is $T_2 = -15^\circ\text{C}$ are

$$q_x'' = -k \frac{dT}{dx} = k \frac{T_1 - T_2}{L} = 1 \text{ W/m} \cdot \text{K} \frac{25^\circ\text{C} - (-15^\circ\text{C})}{0.30 \text{ m}} = 133.3 \text{ W/m}^2. \quad (1)$$

$$q_x = q_x'' \times A = 133.3 \text{ W/m}^2 \times 20 \text{ m}^2 = 2667 \text{ W}. \quad (2) <$$

Combining Eqs. (1) and (2), the heat rate q_x can be determined for the range of outer surface temperature, $-15 \leq T_2 \leq 38^\circ\text{C}$, with different wall thermal conductivities, k .

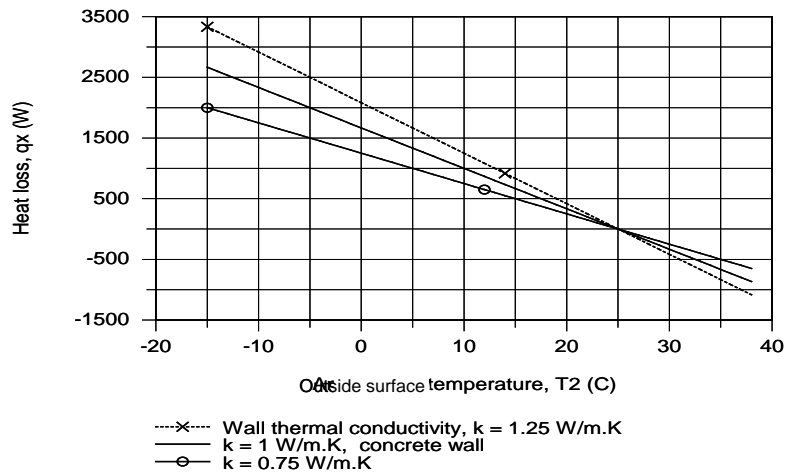

For the concrete wall, $k = 1 \text{ W/m}\cdot\text{K}$, the heat loss varies linearly from $+2667 \text{ W}$ to -867 W and is zero when the inside and outer surface temperatures are the same. The magnitude of the heat rate increases with increasing thermal conductivity.

COMMENTS: Without steady-state conditions and constant k , the temperature distribution in a plane wall would not be linear.

PROBLEM 1.5

KNOWN: Dimensions, thermal conductivity and surface temperatures of a concrete slab. Efficiency of gas furnace and cost of natural gas.

FIND: Daily cost of heat loss.

SCHEMATIC:

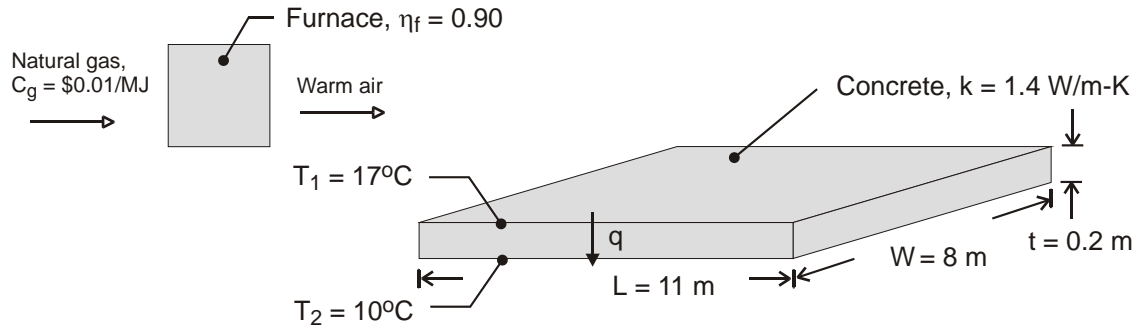

ASSUMPTIONS: (1) Steady state, (2) One-dimensional conduction, (3) Constant properties.

ANALYSIS: The rate of heat loss by conduction through the slab is

$$q = k(LW) \frac{T_1 - T_2}{t} = 1.4 \text{ W/m} \cdot \text{K} (11 \text{ m} \times 8 \text{ m}) \frac{7^\circ\text{C}}{0.20 \text{ m}} = 4312 \text{ W} \quad <$$

The daily cost of natural gas that must be combusted to compensate for the heat loss is

$$C_d = \frac{q C_g}{\eta_f} (\Delta t) = \frac{4312 \text{ W} \times \$0.02 / \text{MJ}}{0.9 \times 10^6 \text{ J/MJ}} (24 \text{ h/d} \times 3600 \text{ s/h}) = \$8.28 / \text{d} \quad <$$

COMMENTS: The loss could be reduced by installing a floor covering with a layer of insulation between it and the concrete.

PROBLEM 1.6

KNOWN: Heat flux and surface temperatures associated with a wood slab of prescribed thickness.

FIND: Thermal conductivity, k , of the wood.

SCHEMATIC:

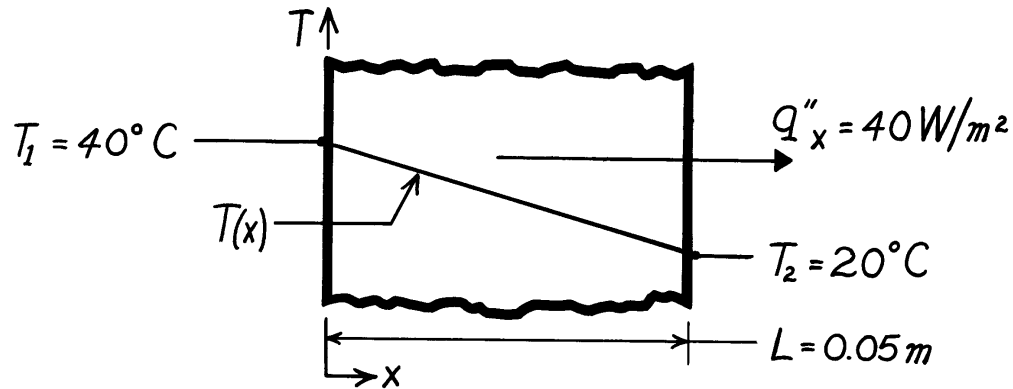

ASSUMPTIONS: (1) One-dimensional conduction in the x-direction, (2) Steady-state conditions, (3) Constant properties.

ANALYSIS: Subject to the foregoing assumptions, the thermal conductivity may be determined from Fourier's law, Eq. 1.2. Rearranging,

$$k = q''_x \frac{L}{T_1 - T_2} = 40 \frac{\text{W}}{\text{m}^2} \frac{0.05 \text{ m}}{(40 - 20)^\circ \text{C}}$$

$$k = 0.10 \text{ W/m} \cdot \text{K}.$$

<

COMMENTS: Note that the $^\circ \text{C}$ or K temperature units may be used interchangeably when evaluating a temperature difference.

PROBLEM 1.7

KNOWN: Inner and outer surface temperatures and thermal resistance of a glass window of prescribed dimensions.

FIND: Heat loss through window. Thermal conductivity of glass.

SCHEMATIC:

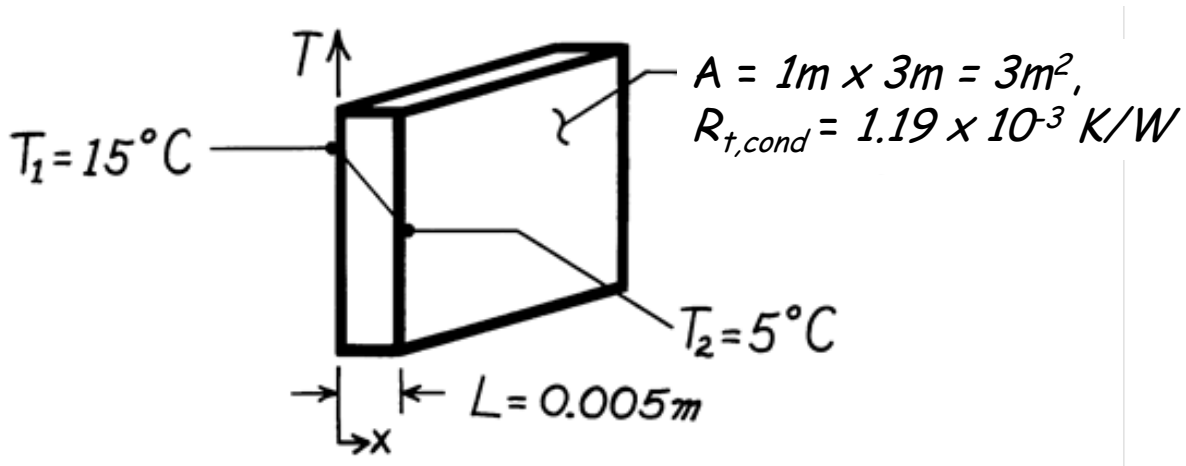

ASSUMPTIONS: (1) One-dimensional conduction in the x -direction, (2) Steady-state conditions, (3) Constant properties.

ANALYSIS: From Eq. 1.11,

$$q_x = \frac{T_1 - T_2}{R_{t,\text{cond}}} = \frac{(15 - 5)^\circ\text{C}}{1.19 \times 10^{-3}\text{ K/W}} = 8400\text{ W} \quad <$$

The thermal resistance due to conduction for a plane wall is related to the thermal conductivity and dimensions according to

$$R_{t,\text{cond}} = L/kA$$

Therefore

$$k = L/(R_{t,\text{cond}}A) = 0.005\text{ m} / (1.19 \times 10^{-3}\text{ K/W} \times 3\text{ m}^2) = 1.40\text{ W/m}\cdot\text{K} \quad <$$

COMMENTS: The thermal conductivity value agrees with the value for glass in Table A.3.

PROBLEM 1.8

KNOWN: Net power output, average compressor and turbine temperatures, shaft dimensions and thermal conductivity.

FIND: (a) Comparison of the conduction rate through the shaft to the predicted net power output of the device, (b) Plot of the ratio of the shaft conduction heat rate to the anticipated net power output of the device over the range $0.005 \text{ m} \leq L \leq 1 \text{ m}$ and feasibility of a $L = 0.005 \text{ m}$ device.

SCHEMATIC:

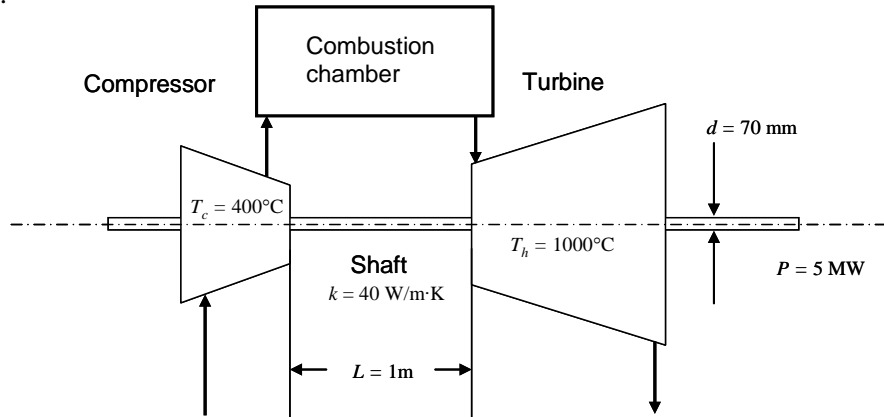

ASSUMPTIONS: (1) Steady-state conditions, (2) Constant properties, (3) Net power output is proportional to the volume of the gas turbine.

PROPERTIES: Shaft (given): $k = 40 \text{ W/m}\cdot\text{K}$.

ANALYSIS: (a) The conduction through the shaft may be evaluated using Fourier's law, yielding

$$q = q'' A_c = \frac{k(T_h - T_c)}{L} (\pi d^2 / 4) = \frac{40 \text{ W/m}\cdot\text{K} (1000 - 400)^\circ\text{C}}{1 \text{ m}} (\pi (70 \times 10^{-3} \text{ m})^2 / 4) = 92.4 \text{ W}$$

The ratio of the conduction heat rate to the net power output is

$$r = \frac{q}{P} = \frac{92.4 \text{ W}}{5 \times 10^6 \text{ W}} = 18.5 \times 10^{-6} \quad <$$

(b) The volume of the turbine is proportional to L^3 . Designating $L_a = 1 \text{ m}$, $d_a = 70 \text{ mm}$ and P_a as the shaft length, shaft diameter, and net power output, respectively, in part (a),

$$d = d_a \times (L/L_a); P = P_a \times (L/L_a)^3$$

and the ratio of the conduction heat rate to the net power output is

$$\begin{aligned} r &= \frac{q'' A_c}{P} = \frac{\frac{k(T_h - T_c)}{L} (\pi d^2 / 4)}{P} = \frac{\frac{k(T_h - T_c)}{L} (\pi (d_a L / L_a)^2 / 4)}{P_a (L / L_a)^3} = \frac{\frac{k(T_h - T_c) \pi}{4} d_a^2 L_a / P_a}{L^2} \\ &= \frac{\frac{40 \text{ W/m}\cdot\text{K} (1000 - 400)^\circ\text{C} \pi}{4} (70 \times 10^{-3} \text{ m})^2 \times 1 \text{ m} / 5 \times 10^6 \text{ W}}{L^2} = \frac{18.5 \times 10^{-6} \text{ m}^2}{L^2} \end{aligned}$$

Continued...

PROBLEM 1.8 (Cont.)

The ratio of the shaft conduction to net power is shown below. At $L = 0.005 \text{ m} = 5 \text{ mm}$, the shaft conduction to net power output ratio is 0.74. The concept of the very small turbine is not feasible since it will be unlikely that the large temperature difference between the compressor and turbine can be maintained. <

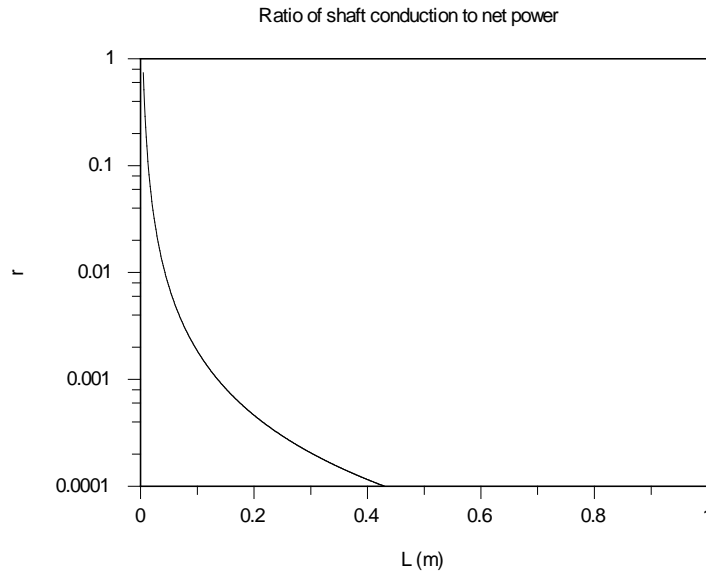

COMMENTS: (1) The thermodynamics analysis does not account for heat transfer effects and is therefore meaningful only when heat transfer can be safely ignored, as is the case for the shaft in part (a). (2) Successful miniaturization of thermal devices is often hindered by heat transfer effects that must be overcome with innovative design.

PROBLEM 1.9

KNOWN: Heat flux at one face and air temperature and convection coefficient at other face of plane wall. Temperature of surface exposed to convection.

FIND: If steady-state conditions exist. If not, whether the temperature is increasing or decreasing.

SCHEMATIC:

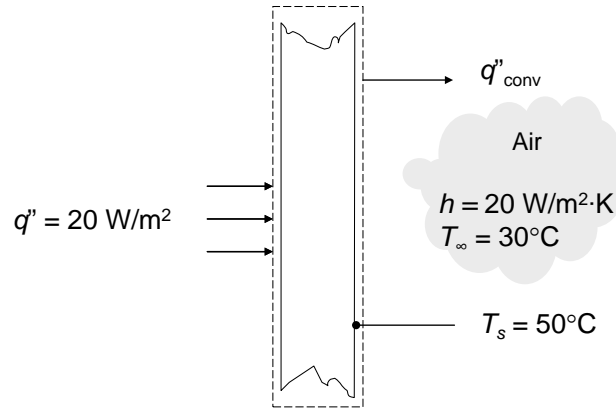

ASSUMPTIONS: (1) One-dimensional conduction, (2) No internal energy generation.

ANALYSIS: Conservation of energy for a control volume around the wall gives

$$\frac{dE_{st}}{dt} = \dot{E}_{in} - \dot{E}_{out} + \dot{E}_g$$

$$\begin{aligned}\frac{dE_{st}}{dt} &= q''_{in}A - hA(T_s - T_{\infty}) = [q''_{in} - h(T_s - T_{\infty})]A \\ &= [20 \text{ W/m}^2 - 20 \text{ W/m}^2 \cdot \text{K}(50^{\circ}\text{C} - 30^{\circ}\text{C})]A = -380 \text{ W/m}^2A\end{aligned}$$

Since $dE_{st}/dt \neq 0$, the system is not at steady-state. <

Since $dE_{st}/dt < 0$, the stored energy is decreasing, therefore the wall temperature is decreasing. <

COMMENTS: When the surface temperature of the face exposed to convection cools to 31°C , $q_{in} = q_{out}$ and $dE_{st}/dt = 0$ and the wall will have reached steady-state conditions.

PROBLEM 1.10

KNOWN: Expression for variable thermal conductivity of a wall. Constant heat flux. Temperature at $x = 0$.

FIND: Expression for temperature gradient and temperature distribution.

SCHEMATIC:

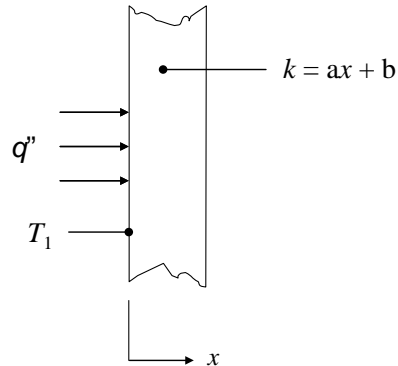

ASSUMPTIONS: (1) One-dimensional conduction.

ANALYSIS: The heat flux is given by Fourier's law, and is known to be constant, therefore

$$q_x'' = -k \frac{dT}{dx} = \text{constant}$$

Solving for the temperature gradient and substituting the expression for k yields

$$\frac{dT}{dx} = -\frac{q_x''}{k} = -\frac{q_x''}{ax + b} \quad <$$

This expression can be integrated to find the temperature distribution, as follows:

$$\int \frac{dT}{dx} dx = -\int \frac{q_x''}{ax + b} dx$$

Since $q_x'' = \text{constant}$, we can integrate the right hand side to find

$$T = -\frac{q_x''}{a} \ln(ax + b) + c$$

where c is a constant of integration. Applying the known condition that $T = T_1$ at $x = 0$, we can solve for c .

Continued...

PROBLEM 1.10 (Cont.)

$$\begin{aligned}T(x = 0) &= T_1 \\ -\frac{q_x''}{a} \ln b + c &= T_1 \\ c &= T_1 + \frac{q_x''}{a} \ln b\end{aligned}$$

Therefore, the temperature distribution is given by

$$\begin{aligned}T &= -\frac{q_x''}{a} \ln(ax + b) + T_1 + \frac{q_x''}{a} \ln b &< \\ &= T_1 + \frac{q_x''}{a} \ln \frac{b}{ax + b} &<\end{aligned}$$

COMMENTS: Temperature distributions are not linear in many situations, such as when the thermal conductivity varies spatially or is a function of temperature. Non-linear temperature distributions may also evolve if internal energy generation occurs or non-steady conditions exist.

PROBLEM 1.11

KNOWN: Thickness, diameter and inner surface temperature of bottom of pan used to boil water. Rate of heat transfer to the pan.

FIND: Outer surface temperature of pan for an aluminum and a copper bottom.

SCHEMATIC:

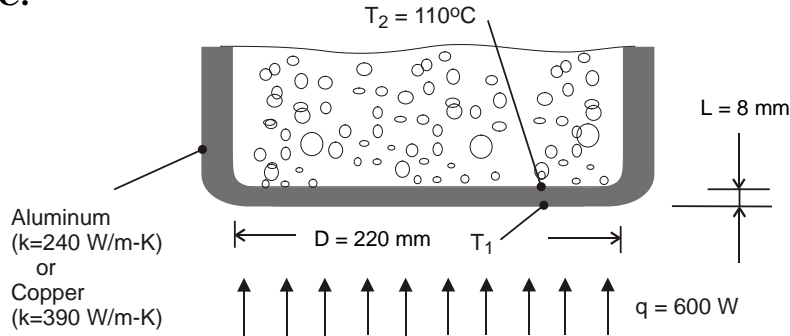

ASSUMPTIONS: (1) One-dimensional, steady-state conduction through bottom of pan.

ANALYSIS: From Fourier's law, the rate of heat transfer by conduction through the bottom of the pan is

$$q = kA \frac{T_1 - T_2}{L}$$

Hence,

$$T_1 = T_2 + \frac{qL}{kA}$$

where $A = \pi D^2 / 4 = \pi (0.22 \text{ m})^2 / 4 = 0.038 \text{ m}^2$.

$$\text{Aluminum: } T_1 = 110^\circ\text{C} + \frac{600 \text{ W} (0.008 \text{ m})}{240 \text{ W/m}\cdot\text{K} (0.038 \text{ m}^2)} = 110.5^\circ\text{C} \quad <$$

$$\text{Copper: } T_1 = 110^\circ\text{C} + \frac{600 \text{ W} (0.008 \text{ m})}{390 \text{ W/m}\cdot\text{K} (0.038 \text{ m}^2)} = 110.3^\circ\text{C} \quad <$$

COMMENTS: Although the temperature drop across the bottom is slightly larger for aluminum (due to its smaller thermal conductivity), it is sufficiently small to be negligible for both materials. To a good approximation, the bottom may be considered *isothermal* at $T \approx 110^\circ\text{C}$, which is a desirable feature of pots and pans.

PROBLEM 1.12

KNOWN: Hand experiencing convection heat transfer with moving air and water.

FIND: Determine which condition feels colder. Contrast these results with a heat loss of 30 W/m^2 under normal room conditions.

SCHEMATIC:

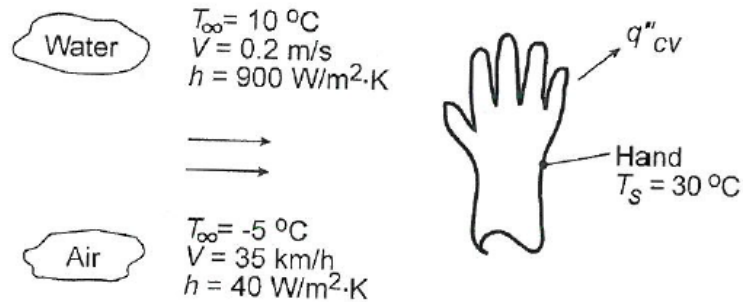

ASSUMPTIONS: (1) Temperature is uniform over the hand's surface, (2) Convection coefficient is uniform over the hand, and (3) Negligible radiation exchange between hand and surroundings in the case of air flow.

ANALYSIS: The hand will feel colder for the condition which results in the larger heat loss. The heat loss can be determined from Newton's law of cooling, Eq. 1.3a, written as

$$q'' = h(T_s - T_\infty)$$

For the air stream:

$$q''_{\text{air}} = 40 \text{ W/m}^2 \cdot \text{K} [30 - (-8)] \text{ K} = 1,520 \text{ W/m}^2 \quad <$$

For the water stream:

$$q''_{\text{water}} = 900 \text{ W/m}^2 \cdot \text{K} (30 - 10) \text{ K} = 18,000 \text{ W/m}^2 \quad <$$

COMMENTS: The heat loss for the hand in the water stream is an order of magnitude larger than when in the air stream for the given temperature and convection coefficient conditions. In contrast, the heat loss in a normal room environment is only 30 W/m^2 which is a factor of 50 times less than the loss in the air stream. In the room environment, the hand would feel comfortable; in the air and water streams, as you probably know from experience, the hand would feel uncomfortably cold since the heat loss is excessively high.

PROBLEM 1.13

KNOWN: Power required to maintain the surface temperature of a long, 25-mm diameter cylinder with an imbedded electrical heater for different air velocities.

FIND: (a) Determine the convection coefficient for each of the air velocity conditions and display the results graphically, and (b) Assuming that the convection coefficient depends upon air velocity as $h = CV^n$, determine the parameters C and n.

SCHEMATIC:

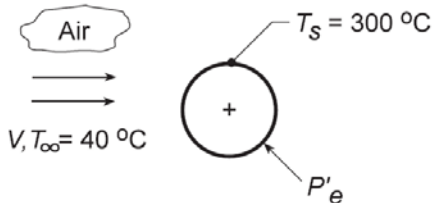

V (m/s)	1	2	4	8	12
P'_e (W/m)	450	658	983	1507	1963
h (W/m ² ·K)	22.0	32.2	48.1	73.8	96.1

ASSUMPTIONS: (1) Temperature is uniform over the cylinder surface, (2) Negligible radiation exchange between the cylinder surface and the surroundings, (3) Steady-state conditions.

ANALYSIS: (a) From an overall energy balance on the cylinder, the power dissipated by the electrical heater is transferred by convection to the air stream. Using Newton's law of cooling on a per unit length basis,

$$P'_e = h(\pi D)(T_s - T_\infty)$$

where P'_e is the electrical power dissipated per unit length of the cylinder. For the $V = 1$ m/s condition, using the data from the table above, find

$$h = 450 \text{ W/m} / \pi \times 0.025 \text{ m} (300 - 40)^\circ \text{C} = 22.0 \text{ W/m}^2 \cdot \text{K}$$

Repeating the calculations, find the convection coefficients for the remaining conditions which are tabulated above and plotted below. Note that h is not linear with respect to the air velocity.

(b) To determine the (C,n) parameters, we plotted h vs. V on log-log coordinates. Choosing $C = 22.12 \text{ W/m}^2 \cdot \text{K}(\text{s/m})^n$, assuring a match at $V = 1$, we can readily find the exponent n from the slope of the h vs. V curve. From the trials with $n = 0.8, 0.6$ and 0.5 , we recognize that $n = 0.6$ is a reasonable choice. Hence, $C = 22.12$ and $n = 0.6$.

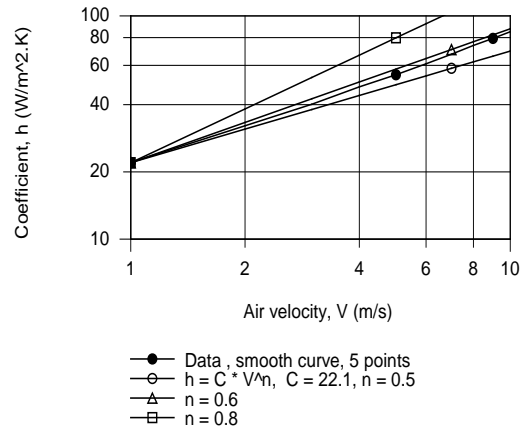
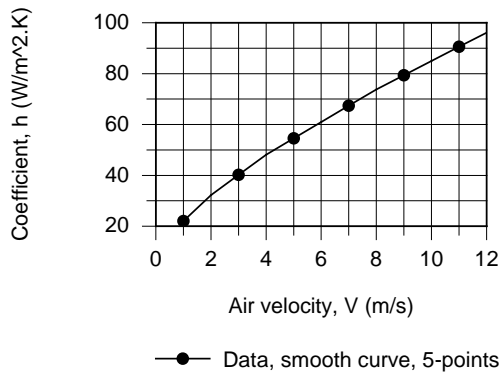

COMMENTS: Radiation may not be negligible, depending on surface emissivity.

PROBLEM 1.14

KNOWN: Inner and outer surface temperatures of a wall. Inner and outer air temperatures and convection heat transfer coefficients.

FIND: Heat flux from inner air to wall. Heat flux from wall to outer air. Heat flux from wall to inner air. Whether wall is under steady-state conditions.

SCHEMATIC:

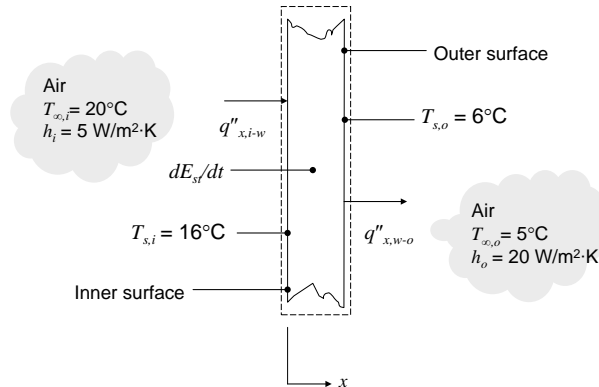

ASSUMPTIONS: (1) Negligible radiation, (2) No internal energy generation.

ANALYSIS: The heat fluxes can be calculated using Newton's law of cooling. Convection from the inner air to the wall occurs in the positive x-direction:

$$q''_{x,i-w} = h_i(T_{\infty,i} - T_{s,i}) = 5 \text{ W/m}^2 \cdot \text{K} \times (20^\circ\text{C} - 16^\circ\text{C}) = 20 \text{ W/m}^2 \quad <$$

Convection from the wall to the outer air also occurs in the positive x-direction:

$$q''_{x,w-o} = h_o(T_{s,o} - T_{\infty,o}) = 20 \text{ W/m}^2 \cdot \text{K} \times (6^\circ\text{C} - 5^\circ\text{C}) = 20 \text{ W/m}^2 \quad <$$

From the wall to the inner air:

$$q''_{w-i} = h_i(T_{s,i} - T_{\infty,i}) = 5 \text{ W/m}^2 \cdot \text{K} \times (16^\circ\text{C} - 20^\circ\text{C}) = -20 \text{ W/m}^2 \quad <$$

An energy balance on the wall gives

$$\frac{dE_{st}}{dt} = \dot{E}_{in} - \dot{E}_{out} = A(q''_{x,i-w} - q''_{x,w-o}) = 0$$

Since $dE_{st}/dt = 0$, the wall *could be* at steady-state and the *spatially-averaged* wall temperature is not changing. However, it is possible that stored energy is increasing in one part of the wall and decreasing in another, therefore we cannot tell if the wall is at steady-state or not. If we found $dE_{st}/dt \neq 0$, we would know the wall was not at steady-state. <

COMMENTS: The heat flux from the wall to the inner air is equal and opposite to the heat flux from the inner air to the wall.

PROBLEM 1.15

KNOWN: Hot vertical plate suspended in cool, still air. Change in plate temperature with time at the instant when the plate temperature is 245°C.

FIND: Convection heat transfer coefficient for this condition.

SCHEMATIC:

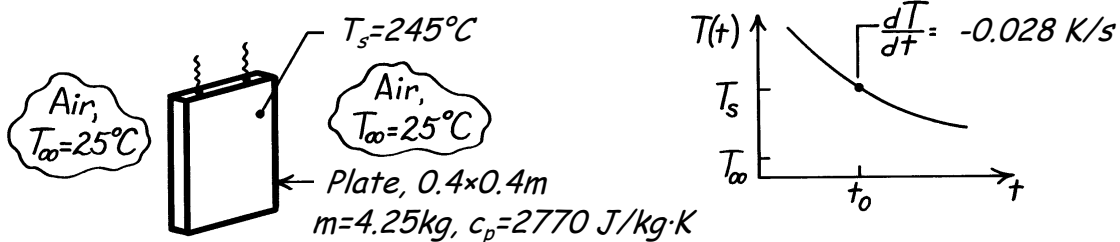

ASSUMPTIONS: (1) Plate is isothermal, (2) Negligible radiation exchange with surroundings, (3) Negligible heat lost through suspension wires.

ANALYSIS: As shown in the cooling curve above, the plate temperature decreases with time. The condition of interest is for time t_0 . For a control surface about the plate, the conservation of energy requirement is

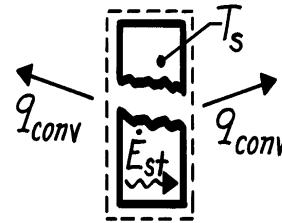

$$\dot{E}_{in} - \dot{E}_{out} = \dot{E}_{st}$$

$$-2hA_s(T_s - T_\infty) = mc_p \frac{dT}{dt}$$

where A_s is the surface area of one side of the plate. Solving for h , find

$$h = \frac{mc_p}{2A_s(T_s - T_\infty)} \left(\frac{-dT}{dt} \right)$$

$$h = \frac{4.25 \text{ kg} \times 2770 \text{ J/kg}\cdot\text{K}}{2 \times (0.4 \times 0.4) \text{ m}^2 (245 - 25) \text{ K}} \times 0.028 \text{ K/s} = 4.7 \text{ W/m}^2 \cdot \text{K} \quad <$$

COMMENTS: (1) Assuming the plate is very highly polished with emissivity of 0.08, determine whether radiation exchange with the surroundings at 25°C is negligible compared to convection.

(2) We will later consider the criterion for determining whether the isothermal plate assumption is reasonable. If the thermal conductivity of the present plate were high (such as aluminum or copper), the criterion would be satisfied.

PROBLEM 1.16

KNOWN: Width, input power and efficiency of a transmission. Temperature and convection coefficient associated with air flow over the casing.

FIND: Surface temperature of casing. Thermal convection resistance.

SCHEMATIC:

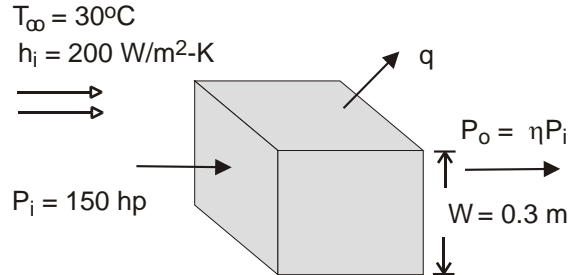

ASSUMPTIONS: (1) Steady state, (2) Uniform convection coefficient and surface temperature, (3) Negligible radiation.

ANALYSIS: From Newton's law of cooling,

$$q = hA_s (T_s - T_\infty) = 6hW^2 (T_s - T_\infty)$$

where the output power is ηP_i and the heat rate is

$$q = P_i - P_o = P_i (1 - \eta) = 150 \text{ hp} \times 746 \text{ W / hp} \times 0.07 = 7833 \text{ W}$$

Hence,

$$T_s = T_\infty + \frac{q}{6hW^2} = 30^\circ\text{C} + \frac{7833 \text{ W}}{6 \times 200 \text{ W / m}^2 \cdot \text{K} \times (0.3 \text{ m})^2} = 102.5^\circ\text{C} \quad <$$

From Eq. 1.11, the thermal resistance due to convection is

$$R_{t,\text{conv}} = \Delta T / q_x = (T_s - T_\infty) / q_x = (102.5 - 30) \text{ K} / 7833 \text{ W} = 0.00926 \text{ K/W} \quad <$$

COMMENTS: (1) There will, in fact, be considerable variability of the local convection coefficient over the transmission case and the prescribed value represents an average over the surface. (2) The convection thermal resistance could equivalently be calculated from $R_{t,\text{conv}} = 1/hA$.

PROBLEM 1.17

KNOWN: Dimensions of a cartridge heater. Heater power. Convection coefficients in air and water at a prescribed temperature.

FIND: Thermal convection resistance and heater surface temperatures in water and air.

SCHEMATIC

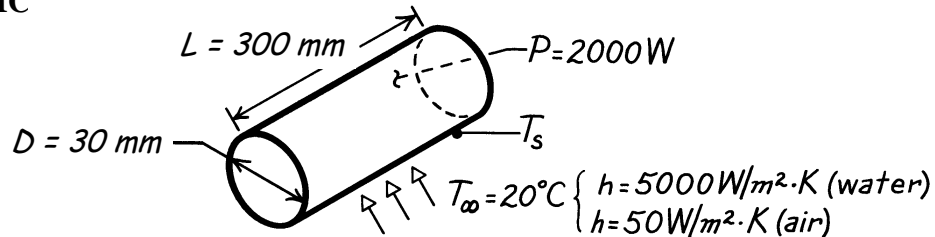

ASSUMPTIONS: (1) Steady-state conditions, (2) All of the electrical power is transferred to the fluid by convection, (3) Negligible heat transfer from ends.

ANALYSIS: With $P = q_{\text{conv}}$, Newton's law of cooling yields

$$P = hA(T_s - T_\infty) = h\pi DL(T_s - T_\infty)$$

$$T_s = T_\infty + \frac{P}{h\pi DL}$$

From Eq. 1.11, the thermal resistance due to convection is given by

$$R_{t,\text{conv}} = \Delta T / q_x = (T_s - T_\infty) / P = 1 / h\pi DL$$

In water,

$$T_s = 20^\circ\text{C} + \frac{2000 \text{ W}}{5000 \text{ W/m}^2 \cdot \text{K} \times \pi \times 0.03 \text{ m} \times 0.3 \text{ m}} = 34.2^\circ\text{C} \quad <$$

$$R_{t,\text{conv}} = 1 / h\pi DL = 1 / (5000 \text{ W/m}^2 \cdot \text{K} \times \pi \times 0.03 \text{ m} \times 0.3 \text{ m}) = 0.00707 \text{ K/W} \quad <$$

In air,

$$T_s = 20^\circ\text{C} + \frac{2000 \text{ W}}{50 \text{ W/m}^2 \cdot \text{K} \times \pi \times 0.03 \text{ m} \times 0.3 \text{ m}} = 1435^\circ\text{C} \quad <$$

$$R_{t,\text{conv}} = 1 / h\pi DL = 1 / (50 \text{ W/m}^2 \cdot \text{K} \times \pi \times 0.03 \text{ m} \times 0.3 \text{ m}) = 0.707 \text{ K/W} \quad <$$

COMMENTS: (1) Air is much less effective than water as a heat transfer fluid. Hence, the cartridge temperature is much higher in air, so high, in fact, that the cartridge would melt. (2) In air, the high cartridge temperature would render radiation significant. (3) Larger thermal resistance corresponds to less effective heat transfer.

PROBLEM 1.18

KNOWN: Length, diameter and calibration of a hot wire anemometer. Temperature of air stream. Current, voltage drop and surface temperature of wire for a particular application.

FIND: Air velocity

SCHEMATIC:

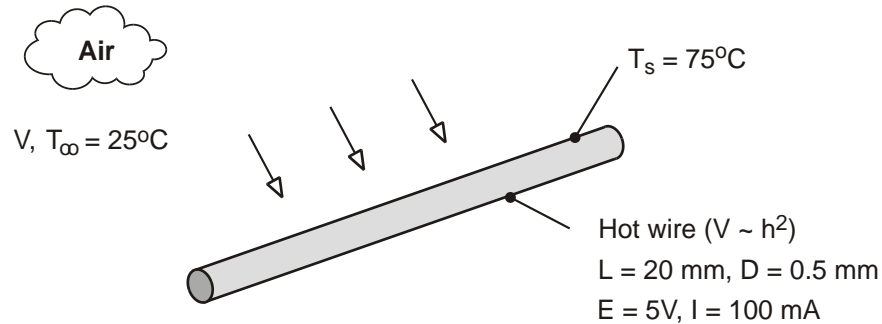

ASSUMPTIONS: (1) Steady-state conditions, (2) Negligible heat transfer from the wire by natural convection or radiation.

ANALYSIS: If all of the electric energy is transferred by convection to the air, the following equality must be satisfied

$$P_{\text{elec}} = EI = hA(T_s - T_\infty)$$

where $A = \pi DL = \pi(0.0005\text{m} \times 0.02\text{m}) = 3.14 \times 10^{-5} \text{m}^2$.

Hence,

$$h = \frac{EI}{A(T_s - T_\infty)} = \frac{5\text{V} \times 0.1\text{A}}{3.14 \times 10^{-5} \text{m}^2 (50^\circ\text{C})} = 318 \text{ W/m}^2 \cdot \text{K}$$

$$V = 6.25 \times 10^{-5} h^2 = 6.25 \times 10^{-5} (318 \text{ W/m}^2 \cdot \text{K})^2 = 6.3 \text{ m/s} \quad <$$

COMMENTS: The convection coefficient is sufficiently large to render buoyancy (natural convection) and radiation effects negligible.

PROBLEM 1.19

KNOWN: Chip width and maximum allowable temperature. Coolant conditions.

FIND: Maximum allowable chip power for air and liquid coolants.

SCHEMATIC:

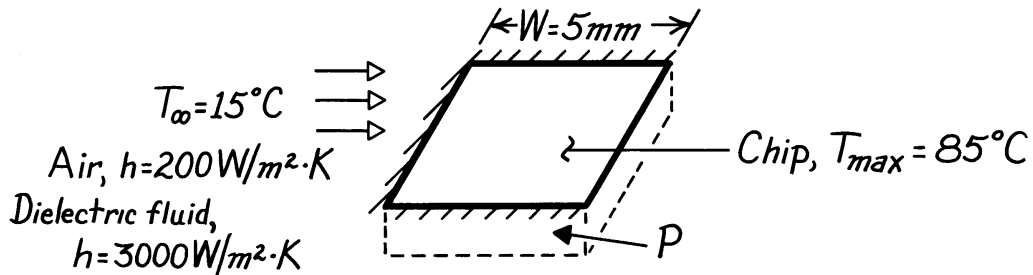

ASSUMPTIONS: (1) Steady-state conditions, (2) Negligible heat transfer from sides and bottom, (3) Chip is at a uniform temperature (isothermal), (4) Negligible heat transfer by radiation in air.

ANALYSIS: All of the electrical power dissipated in the chip is transferred by convection to the coolant. Hence,

$$P = q$$

and from Newton's law of cooling,

$$P = hA(T - T_{\infty}) = hW^2(T - T_{\infty}).$$

In *air*,

$$P_{\max} = 200 \text{ W/m}^2 \cdot \text{K} (0.005 \text{ m})^2 (85 - 15) ^\circ \text{C} = 0.35 \text{ W}. \quad <$$

In the *dielectric liquid*

$$P_{\max} = 3000 \text{ W/m}^2 \cdot \text{K} (0.005 \text{ m})^2 (85 - 15) ^\circ \text{C} = 5.25 \text{ W}. \quad <$$

COMMENTS: Relative to liquids, air is a poor heat transfer fluid. Hence, in air the chip can dissipate far less energy than in the dielectric liquid.

PROBLEM 1.20

KNOWN: Heat flux and convection heat transfer coefficient for boiling water. Saturation temperature and convection heat transfer coefficient for boiling dielectric fluid.

FIND: Upper surface temperature of plate when water is boiling. Whether plan for minimizing surface temperature by using dielectric fluid will work.

SCHEMATIC:

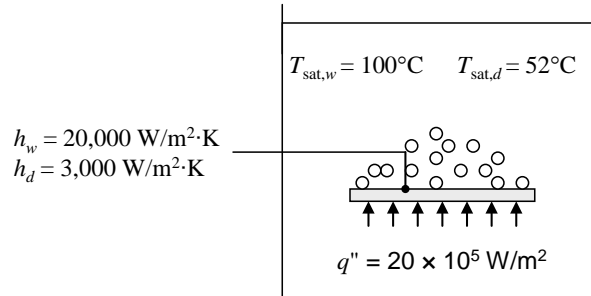

ASSUMPTIONS: Steady-state conditions.

PROPERTIES: $T_{\text{sat},w} = 100^\circ\text{C}$ at $p = 1$ atm.

ANALYSIS: According to the problem statement, Newton's law of cooling can be expressed for a boiling process as

$$q'' = h(T_s - T_{\text{sat}})$$

Thus,

$$T_s = T_{\text{sat}} + q''/h$$

When the fluid is water,

$$T_{s,w} = T_{\text{sat},w} + q''/h_w = 100^\circ\text{C} + \frac{20 \times 10^5 \text{ W/m}^2}{20 \times 10^3 \text{ W/m}^2 \cdot \text{K}} = 200^\circ\text{C}$$

When the dielectric fluid is used,

$$T_{s,d} = T_{\text{sat},d} + q''/h_d = 52^\circ\text{C} + \frac{20 \times 10^5 \text{ W/m}^2}{3 \times 10^3 \text{ W/m}^2 \cdot \text{K}} = 719^\circ\text{C}$$

Thus, the technician's proposed approach will not reduce the surface temperature. <

COMMENTS: (1) Even though the dielectric fluid has a lower saturation temperature, this is more than offset by the lower heat transfer coefficient associated with the dielectric fluid. The surface temperature with the dielectric coolant exceeds the melting temperature of many metals such as aluminum and aluminum alloys. (2) Dielectric fluids are, however, employed in applications such as *immersion cooling* of electronic components, where an electrically-conducting fluid such as water could not be used.

PROBLEM 1.21

KNOWN: Ambient, surface, and surroundings temperatures, convection heat transfer coefficient, and absorptivity of a plane wall.

FIND: Convective and radiative heat fluxes to the wall at $x = 0$.

SCHEMATIC:

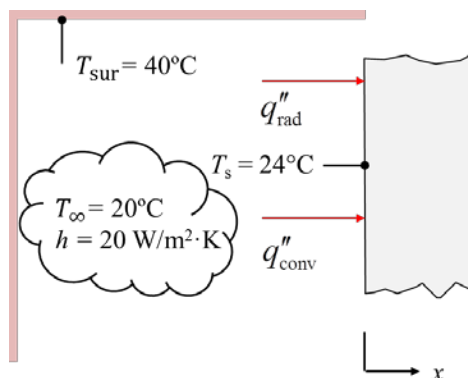

ASSUMPTIONS: (1) Exposed wall surface is gray ($\alpha = \epsilon$), (2) large surroundings.

ANALYSIS: The convection heat flux to the wall is described by Newton's law of cooling,

$$q''_{\text{conv}} = h(T_{\infty} - T_1) = 20 \text{ W/m}^2 \cdot \text{K} \times (20^{\circ}\text{C} - 24^{\circ}\text{C}) = -80 \text{ W/m}^2 <$$

The negative sign indicates that the convection heat transfer is from the wall to the ambient.

The net radiation heat flux to the wall is determined from

$$q''_{\text{rad}} = \epsilon\sigma(T_{\text{sur}}^4 - T_s^4) = 0.78 \times 5.67 \times 10^{-8} \text{ W/m}^2 \cdot \text{K}^4 \times \left((40 + 273)^4 - (24 + 273)^4 \right) \text{ K}^4 = 80 \text{ W/m}^2 <$$

The net radiation heat flux is to the wall from the surroundings.

Since the radiation and convection heat fluxes are equal and opposite, the net heat flux to the wall is zero.

COMMENTS: (1) If the wall is constructed of a thermally-insulating material, its thermal conductivity will be small, and the conduction heat flux inside the wall will also be small. This situation leads to the requirement that the *sum* of the convective and net radiative fluxes at $x = 0$ be small, such as the case here. (2) Note the importance of converting the temperatures to kelvins when solving for the radiation heat flux.

PROBLEM 1.22

KNOWN: Length, diameter, surface temperature and emissivity of steam line. Temperature and convection coefficient associated with ambient air. Efficiency and fuel cost for gas fired furnace.

FIND: (a) Rate of heat loss, (b) Annual cost of heat loss.

SCHEMATIC:

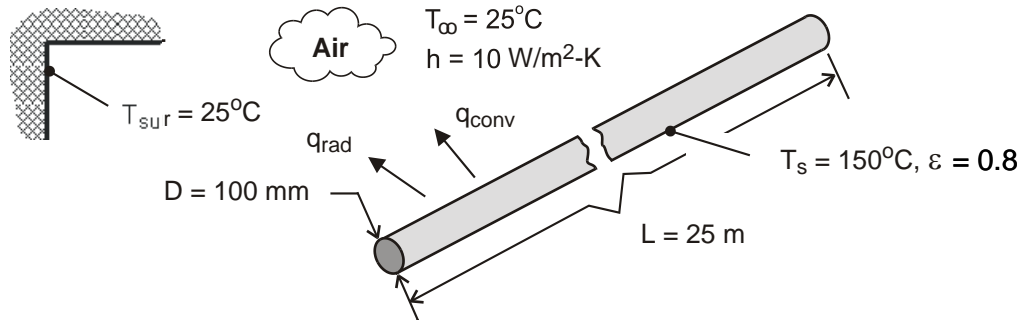

ASSUMPTIONS: (1) Steam line operates continuously throughout year, (2) Net radiation transfer is between small surface (steam line) and large enclosure (plant walls).

ANALYSIS: (a) From Eqs. (1.3a) and (1.7), the heat loss is

$$q = q_{\text{conv}} + q_{\text{rad}} = A \left[h(T_s - T_{\infty}) + \varepsilon \sigma (T_s^4 - T_{\text{sur}}^4) \right]$$

where $A = \pi DL = \pi(0.1\text{m} \times 25\text{m}) = 7.85\text{m}^2$.

Hence,

$$q = 7.85\text{m}^2 \left[10\text{ W/m}^2 \cdot \text{K} (150 - 25)\text{K} + 0.8 \times 5.67 \times 10^{-8}\text{ W/m}^2 \cdot \text{K}^4 (423^4 - 298^4)\text{K}^4 \right]$$

$$q = 7.85\text{m}^2 (1,250 + 1,095)\text{ W/m}^2 = (9813 + 8592)\text{ W} = 18,405\text{ W} \quad <$$

(b) The annual energy loss is

$$E = qt = 18,405\text{ W} \times 3600\text{ s/h} \times 24\text{h/d} \times 365\text{ d/y} = 5.80 \times 10^{11}\text{ J}$$

With a furnace energy consumption of $E_f = E/\eta_f = 6.45 \times 10^{11}\text{ J}$, the annual cost of the loss is

$$C = C_g E_f = 0.02\text{ \$/MJ} \times 6.45 \times 10^5\text{ MJ} = \$12,900 \quad <$$

COMMENTS: The heat loss and related costs are unacceptable and should be reduced by insulating the steam line.

PROBLEM 1.23

KNOWN: Air and wall temperatures of a room. Surface temperature, convection coefficient and emissivity of a person in the room.

FIND: Basis for difference in comfort level between summer and winter. Ratio of thermal convection resistance to thermal radiation resistance in summer and winter.

SCHEMATIC:

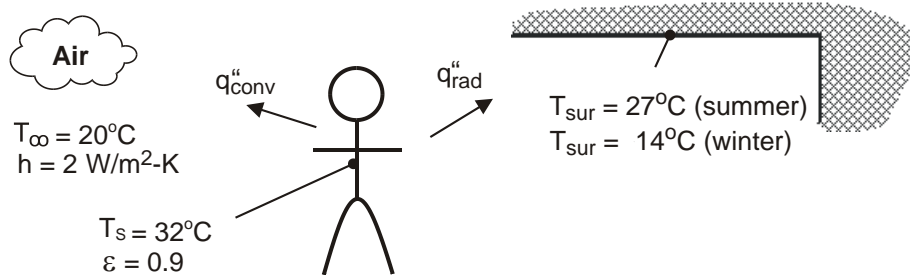

ASSUMPTIONS: (1) Person may be approximated as a small object in a large enclosure.

ANALYSIS: Thermal comfort is linked to heat loss from the human body, and a *chilled* feeling is associated with excessive heat loss. Because the temperature of the room air is fixed, the different summer and winter comfort levels cannot be attributed to convection heat transfer from the body. In both cases, the convection heat flux is

$$\text{Summer and Winter: } q''_{\text{conv}} = h(T_s - T_\infty) = 2 \text{ W/m}^2 \cdot \text{K} \times 12 \text{ }^\circ\text{C} = 24 \text{ W/m}^2$$

However, the heat flux due to radiation will differ, with values of

$$\text{Summer: } q''_{\text{rad}} = \epsilon \sigma (T_s^4 - T_{\text{sur}}^4) = 0.9 \times 5.67 \times 10^{-8} \text{ W/m}^2 \cdot \text{K}^4 (305^4 - 300^4) \text{ K}^4 = 28.3 \text{ W/m}^2$$

$$\text{Winter: } q''_{\text{rad}} = \epsilon \sigma (T_s^4 - T_{\text{sur}}^4) = 0.9 \times 5.67 \times 10^{-8} \text{ W/m}^2 \cdot \text{K}^4 (305^4 - 287^4) \text{ K}^4 = 95.4 \text{ W/m}^2$$

There is a significant difference between winter and summer radiation fluxes, and the chilled condition is attributable to the effect of the colder walls on radiation. <

From Eq. 1.11, the thermal resistance due to convection is

$$R_{t,\text{conv}} = \Delta T / q_{\text{conv}} = (T_s - T_\infty) / q''_{\text{conv}} A$$

and the thermal resistance due to radiation is

$$R_{t,\text{rad}} = \Delta T / q_{\text{rad}} = (T_s - T_{\text{sur}}) / q''_{\text{rad}} A$$

Continued...

PROBLEM 1.23 (Cont.)

Thus the ratio of resistances is

$$\frac{R_{t,\text{conv}}}{R_{t,\text{rad}}} = \frac{(T_s - T_\infty) / q''_{\text{conv}}}{(T_s - T_{\text{sur}}) / q''_{\text{rad}}}$$

$$\text{Summer:} \quad \frac{R_{t,\text{conv}}}{R_{t,\text{rad}}} = \frac{(32 - 20) \text{ K} / 24 \text{ W/m}^2}{(32 - 27) \text{ K} / 28.3 \text{ W/m}^2} = 2.83 \quad <$$

$$\text{Winter:} \quad \frac{R_{t,\text{conv}}}{R_{t,\text{rad}}} = \frac{(32 - 20) \text{ K} / 24 \text{ W/m}^2}{(32 - 14) \text{ K} / 95.4 \text{ W/m}^2} = 2.65 \quad <$$

COMMENTS: (1) For a representative surface area of $A = 1.5 \text{ m}^2$, the heat losses are $q_{\text{conv}} = 36 \text{ W}$, $q_{\text{rad(summer)}} = 42.5 \text{ W}$ and $q_{\text{rad(winter)}} = 143.1 \text{ W}$. The winter time radiation loss is significant and if maintained over a 24 h period would amount to 2,950 kcal. (2) The convection resistance is larger than the radiation resistance but they are the same order of magnitude. There isn't much difference in the resistances between summer and winter conditions; the main difference is the larger *temperature difference* through which radiation occurs in the winter as compared to summer.

PROBLEM 1.24

KNOWN: Diameter and emissivity of spherical interplanetary probe. Power dissipation within probe.

FIND: Probe surface temperature.

SCHEMATIC:

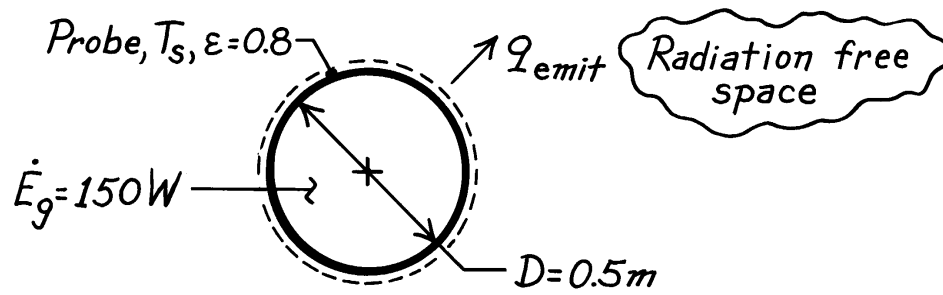

ASSUMPTIONS: (1) Steady-state conditions, (2) Negligible radiation incident on the probe.

ANALYSIS: Conservation of energy dictates a balance between energy generation within the probe and radiation emission from the probe surface. Hence, at any instant

$$-\dot{E}_{\text{out}} + \dot{E}_{\text{g}} = 0$$

$$\varepsilon A_s \sigma T_s^4 = \dot{E}_{\text{g}}$$

$$T_s = \left(\frac{\dot{E}_{\text{g}}}{\varepsilon \pi D^2 \sigma} \right)^{1/4}$$

$$T_s = \left(\frac{150 \text{ W}}{(0.8 \pi (0.5 \text{ m})^2) 5.67 \times 10^{-8} \text{ W/m}^2 \cdot \text{K}^4} \right)^{1/4}$$

$$T_s = 254.7 \text{ K.}$$

<

COMMENTS: Incident radiation, as, for example, from the sun, would increase the surface temperature.

PROBLEM 1.25

KNOWN: Spherical shaped instrumentation package with prescribed surface emissivity within a large space-simulation chamber having walls at 77 K.

FIND: Acceptable power dissipation for operating the package surface temperature in the range $T_s = 40$ to 85°C . Show graphically the effect of emissivity variations for 0.2 and 0.3.

SCHEMATIC:

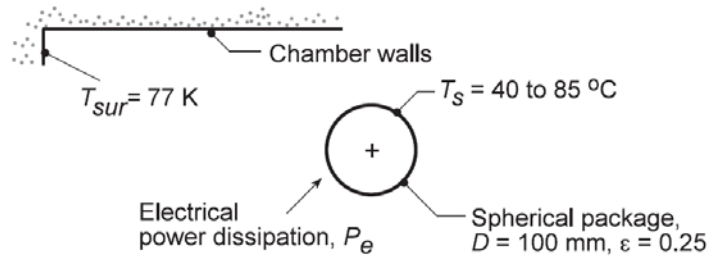

ASSUMPTIONS: (1) Uniform surface temperature, (2) Chamber walls are large compared to the spherical package, and (3) Steady-state conditions.

ANALYSIS: From an overall energy balance on the package, the internal power dissipation P_e will be transferred by radiation exchange between the package and the chamber walls. From Eq. 1.7,

$$q_{rad} = P_e = \epsilon A_s \sigma (T_s^4 - T_{sur}^4)$$

For the condition when $T_s = 40^\circ\text{C}$, with $A_s = \pi D^2$ the power dissipation will be

$$P_e = 0.25 (\pi \times 0.10^2 \text{ m}^2) \times 5.67 \times 10^{-8} \text{ W/m}^2 \cdot \text{K}^4 \times [(40 + 273)^4 - 77^4] \text{ K}^4 = 4.3 \text{ W} \quad \leftarrow$$

Repeating this calculation for the range $40 \leq T_s \leq 85^\circ\text{C}$, we can obtain the power dissipation as a function of surface temperature for the $\epsilon = 0.25$ condition. Similarly, with 0.2 or 0.3, the family of curves shown below has been obtained.

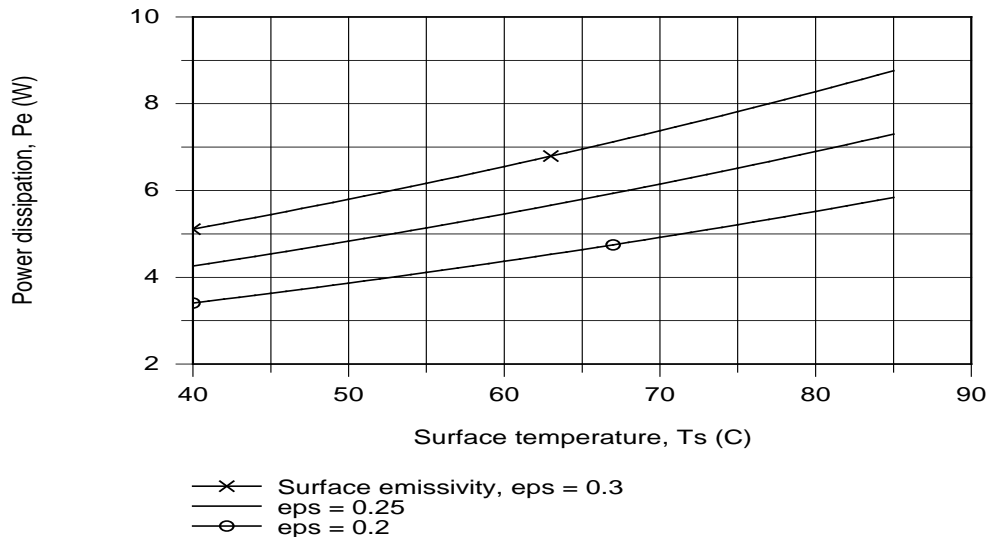

COMMENTS: (1) As expected, the internal power dissipation increases with increasing emissivity and surface temperature. Because the radiation rate equation is non-linear with respect to temperature, the power dissipation will likewise not be linear with surface temperature.

(2) What is the maximum power dissipation that is possible if the surface temperature is not to exceed 85°C ? What kind of a coating should be applied to the instrument package in order to approach this limiting condition?

PROBLEM 1.26

KNOWN: Hot plate suspended in vacuum and surroundings temperature. Mass, specific heat, area and time rate of change of plate temperature.

FIND: (a) The emissivity of the plate, and (b) The rate at which radiation is emitted from the plate.

SCHEMATIC:

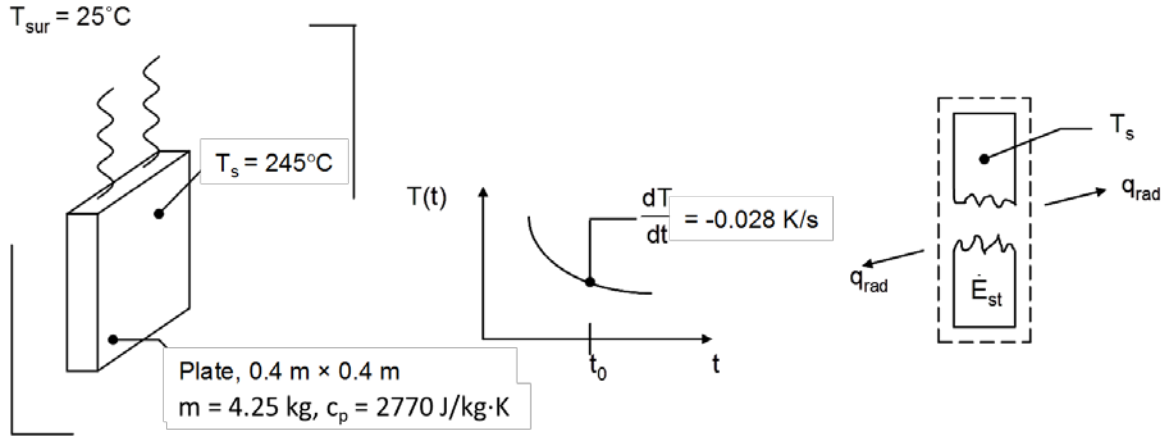

ASSUMPTIONS: (1) Plate is isothermal and at uniform temperature, (2) Large surroundings, (3) Negligible heat loss through suspension wires.

ANALYSIS: For a control volume about the plate, the conservation of energy requirement is

$$\dot{E}_{\text{in}} - \dot{E}_{\text{out}} = \dot{E}_{\text{st}} \quad (1)$$

$$\text{where } \dot{E}_{\text{st}} = mc_p \frac{dT}{dt} \quad (2)$$

$$\text{and for large surroundings } \dot{E}_{\text{in}} - \dot{E}_{\text{out}} = A\epsilon\sigma(T_{\text{sur}}^4 - T_s^4) \quad (3)$$

Combining Eqns. (1) through (3) yields

$$\epsilon = \frac{mc_p \frac{dT}{dt}}{A\sigma (T_{\text{sur}}^4 - T_s^4)}$$

Noting that $T_{\text{sur}} = 25^\circ\text{C} + 273\text{ K} = 298\text{ K}$ and $T_s = 245^\circ\text{C} + 273\text{ K} = 518\text{ K}$, we find

$$\epsilon = \frac{4.25\text{ kg} \times 2770 \frac{\text{J}}{\text{kg}\cdot\text{K}} \times (-0.028 \frac{\text{K}}{\text{s}})}{2 \times 0.4\text{ m} \times 0.4\text{ m} \times 5.67 \times 10^{-8} \frac{\text{W}}{\text{m}^2 \cdot \text{K}^4} (298^4 - 518^4)\text{ K}^4} = 0.28 <$$

The rate at which radiation is emitted from the plate is

$$q_{\text{rad,e}} = \epsilon A \sigma T_s^4 = 0.28 \times 2 \times 0.4\text{ m} \times 0.4\text{ m} \times 5.67 \times 10^{-8} \frac{\text{W}}{\text{m}^2 \cdot \text{K}^4} \times (518\text{ K})^4 = 370\text{ W} <$$

COMMENTS: Note the importance of using kelvins when working with radiation heat transfer.

PROBLEM 1.27

KNOWN: Vacuum enclosure maintained at 97 K by liquid nitrogen shroud while baseplate is maintained at 400 K by an electrical heater.

FIND: (a) Electrical power required to maintain baseplate, (b) Liquid nitrogen consumption rate, (c) Effect on consumption rate if aluminum foil ($\epsilon_p = 0.09$) is bonded to baseplate surface.

SCHEMATIC:

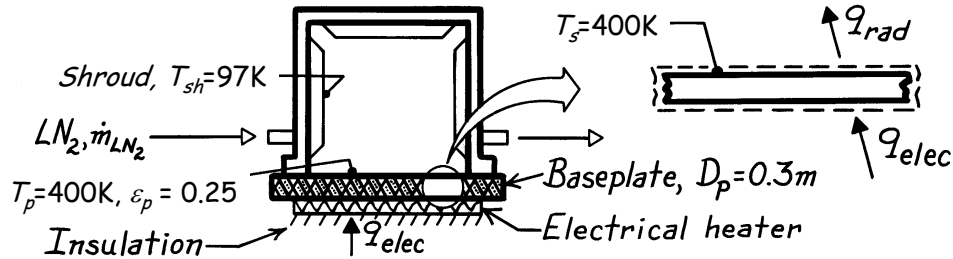

ASSUMPTIONS: (1) Steady-state conditions, (2) No heat losses from backside of heater or sides of plate, (3) Vacuum enclosure large compared to baseplate, (4) Enclosure is evacuated with negligible convection, (5) Liquid nitrogen (LN_2) is heated only by heat transfer to the shroud, and (6) Foil is intimately bonded to baseplate.

PROPERTIES: Heat of vaporization of liquid nitrogen (given): 125 kJ/kg.

ANALYSIS: (a) From an energy balance on the baseplate,

$$\dot{E}_{\text{in}} - \dot{E}_{\text{out}} = 0 \quad q_{\text{elec}} - q_{\text{rad}} = 0$$

and using Eq. 1.7 for radiative exchange between the baseplate and shroud,

$$q_{\text{elec}} = \epsilon_p A_p \sigma (T_p^4 - T_{\text{sh}}^4).$$

Substituting numerical values, with $A_p = (\pi D_p^2 / 4)$, find

$$q_{\text{elec}} = 0.25 \left(\pi (0.3 \text{ m})^2 / 4 \right) 5.67 \times 10^{-8} \text{ W/m}^2 \cdot \text{K}^4 (400^4 - 97^4) \text{ K}^4 = 25.6 \text{ W.} \quad <$$

(b) From an energy balance on the enclosure, radiative transfer heats the liquid nitrogen stream causing evaporation,

$$\dot{E}_{\text{in}} - \dot{E}_{\text{out}} = 0 \quad q_{\text{rad}} - \dot{m}_{\text{LN}_2} h_{\text{fg}} = 0$$

where \dot{m}_{LN_2} is the liquid nitrogen consumption rate. Hence,

$$\dot{m}_{\text{LN}_2} = q_{\text{rad}} / h_{\text{fg}} = 25.6 \text{ W} / 125 \text{ kJ/kg} = 2.05 \times 10^{-4} \text{ kg/s} = 0.736 \text{ kg/h.} \quad <$$

(c) If aluminum foil ($\epsilon_p = 0.09$) were bonded to the upper surface of the baseplate,

$$q_{\text{rad,foil}} = q_{\text{rad}} \left(\epsilon_f / \epsilon_p \right) = 25.6 \text{ W} (0.09 / 0.25) = 9.2 \text{ W}$$

and the liquid nitrogen consumption rate would be reduced by

$$(0.25 - 0.09) / 0.25 = 64\% \text{ to } 0.265 \text{ kg/h.} \quad <$$

PROBLEM 1.28

KNOWN: Storage medium, minimum and maximum temperatures for thermal energy storage, vertical elevation change for potential energy storage.

FIND: Ratio of sensible energy storage capacity to potential energy storage capacity.

SCHEMATIC:

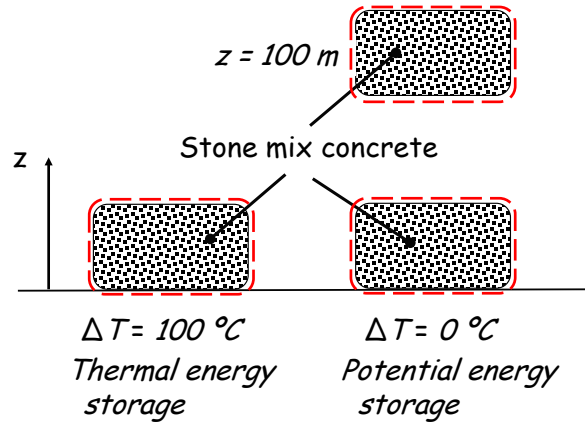

ASSUMPTIONS: (1) Constant properties, (2) Uniform minimum and maximum temperatures.

PROPERTIES: Table A.3, stone mix concrete (300 K): $c_p = c = 880 \text{ J/kg}\cdot\text{K}$.

ANALYSIS: The change in sensible thermal energy storage is due to the temperature change, thus

$$\dot{E}_{\text{st},t} = \frac{dU_t}{dt} = mc \frac{dT}{dt} \quad (1)$$

Integrating Equation 1 over the time period between the minimum and maximum temperatures associated with the thermal energy storage yields

$$\Delta E_{\text{st},t} = mc(T_{\text{max}} - T_{\text{min}}) = mc\Delta T \quad (2)$$

The potential energy storage capacity is

$$\Delta E_{\text{st,PE}} = mgz \quad (3)$$

Combining Equations 2 and 3 yields

$$R = \frac{c\Delta T}{gz} <$$

Continued ...

PROBLEM 1.28 (Cont.)

For stone mix concrete with $\Delta T = 100^\circ\text{C}$ and $z = 100$ m,

$$R = \frac{880 \text{ J/kg} \cdot \text{K} \times 100 \text{ K}}{9.8 \text{ m/s}^2 \times 100 \text{ m}} = 89.8$$

Since $R \gg 1$, thermal energy storage is more effective for the parameters of this problem. <

COMMENTS: (1) Note that $\Delta T = 100^\circ\text{C} = 100 \text{ K}$. (2) The ratio, R , is dimensionless. We shall utilize dimensionless parameters frequently in later chapters. (3) Thermal energy storage can be used in conjunction with solar thermal energy generation. In general, storage of energy in a mechanical form is not as effective as in thermal or chemical forms.

PROBLEM 1.29

KNOWN: Resistor connected to a battery operating at a prescribed temperature in air.

FIND: (a) Considering the resistor as the system, determine corresponding values of \dot{E}_{in} (W), \dot{E}_g (W), \dot{E}_{out} (W) and \dot{E}_{st} (W). If a control surface is placed about the entire system, determine the values of \dot{E}_{in} , \dot{E}_g , \dot{E}_{out} , and \dot{E}_{st} . (b) Determine the volumetric heat generation rate within the resistor, \dot{q} (W/m³), (c) Neglecting radiation from the resistor, determine the convection coefficient.

SCHEMATIC:

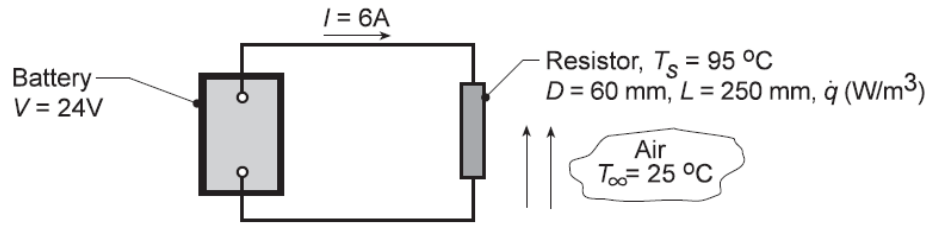

ASSUMPTIONS: (1) Electrical power is dissipated uniformly within the resistor, (2) Temperature of the resistor is uniform, (3) Negligible electrical power dissipated in the lead wires, (4) Negligible radiation exchange between the resistor and the surroundings, (5) No heat transfer occurs from the battery, (5) Steady-state conditions in the resistor.

ANALYSIS: (a) Referring to Section 1.3.1, the conservation of energy requirement for a control volume at an instant of time, Equation 1.12c, is

$$\dot{E}_{in} + \dot{E}_g - \dot{E}_{out} = \dot{E}_{st}$$

where \dot{E}_{in} , \dot{E}_{out} correspond to *surface* inflow and outflow processes, respectively. The energy generation term \dot{E}_g is associated with conversion of some other energy form (chemical, electrical, electromagnetic or nuclear) to thermal energy. The energy storage term \dot{E}_{st} is associated with changes in the internal, kinetic and/or potential energies of the matter in the control volume. \dot{E}_g , \dot{E}_{st} are *volumetric* phenomena. The electrical power delivered by the battery is $P = VI = 24V \times 6A = 144 \text{ W}$.

Control volume: Resistor.

$$\begin{array}{ll} \dot{E}_g = 144 \text{ W} & \dot{E}_{st} = 0 \\ \dot{E}_{in} = 0 & \dot{E}_{out} = 144 \text{ W} \end{array} <$$

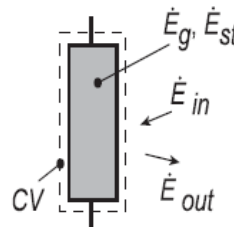

The \dot{E}_g term is due to conversion of electrical energy to thermal energy. The term \dot{E}_{out} is due to convection from the resistor surface to the air.

Continued...

PROBLEM 1.29 (Cont.)

Control volume: Battery-Resistor System.

$$\begin{array}{ll} \dot{E}_{in} = 0 & \dot{E}_{out} = 144 \text{ W} < \\ \dot{E}_g = 144 \text{ W} & \dot{E}_{st} = 0 \end{array}$$

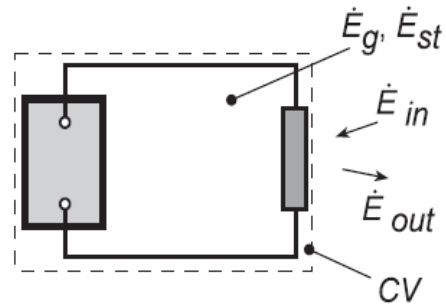

Since we are considering conservation of thermal and mechanical energy, the conversion of chemical energy to electrical energy in the battery is irrelevant, and including the battery in the control volume doesn't change the thermal and mechanical energy terms

(b) From the energy balance on the resistor with volume, $\forall = (\pi D^2/4)L$,

$$\dot{E}_g = \dot{q}\forall \quad 144 \text{ W} = \dot{q} \left(\pi (0.06 \text{ m})^2 / 4 \right) \times 0.25 \text{ m} \quad \dot{q} = 2.04 \times 10^5 \text{ W/m}^3 <$$

(c) From the energy balance on the resistor and Newton's law of cooling with $A_s = \pi DL + 2(\pi D^2/4)$,

$$\dot{E}_{out} = q_{cv} = hA_s (T_s - T_\infty)$$

$$144 \text{ W} = h \left[\pi \times 0.06 \text{ m} \times 0.25 \text{ m} + 2 \left(\pi \times 0.06^2 \text{ m}^2 / 4 \right) \right] (95 - 25)^\circ \text{ C}$$

$$144 \text{ W} = h [0.0471 + 0.0057] \text{ m}^2 (95 - 25)^\circ \text{ C}$$

$$h = 39.0 \text{ W/m}^2 \cdot \text{K} <$$

COMMENTS: (1) In using the conservation of energy requirement, Equation 1.12c, it is important to recognize that \dot{E}_{in} and \dot{E}_{out} will always represent *surface* processes and \dot{E}_g and \dot{E}_{st} , *volumetric* processes. The generation term \dot{E}_g is associated with a *conversion* process from some form of energy to *thermal energy*. The storage term \dot{E}_{st} represents the rate of change of *internal kinetic, and potential energy*.

(2) From Table 1.1 and the magnitude of the convection coefficient determined from part (c), we conclude that the resistor is experiencing forced, rather than free, convection.

PROBLEM 1.30

KNOWN: Inlet and outlet conditions for flow of water in a vertical tube.

FIND: (a) Change in combined thermal and flow work, (b) change in mechanical energy, and (c) change in total energy of the water from the inlet to the outlet of the tube, (d) heat transfer rate, q .

SCHEMATIC:

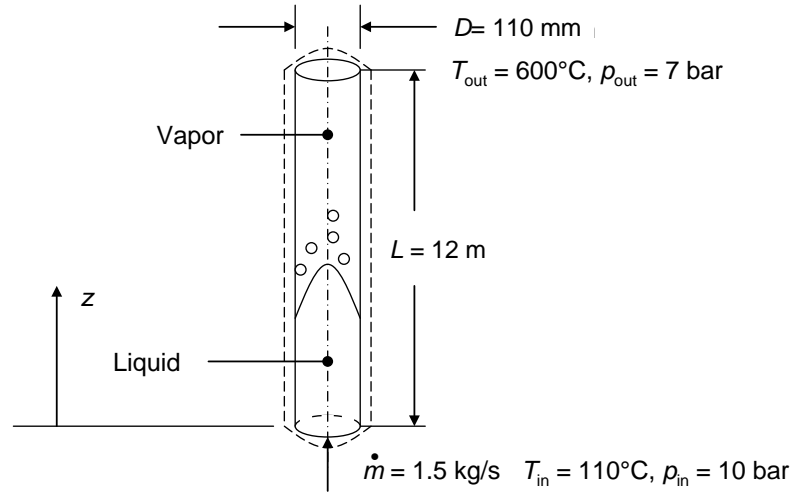

ASSUMPTIONS: (1) Steady-state conditions, (2) Uniform velocity distributions at the tube inlet and outlet.

PROPERTIES: Table A.6 water ($T = 110^\circ\text{C}$): $\rho = 950 \text{ kg/m}^3$, ($T = (179.9^\circ\text{C} + 110^\circ\text{C})/2 = 145^\circ\text{C}$): $c_p = 4300 \text{ J/kg}\cdot\text{K}$, $\rho = 919 \text{ kg/m}^3$. Other properties are taken from Moran, M.J. and Shapiro, H.N., *Fundamentals of Engineering Thermodynamics*, 6th Edition, John Wiley & Sons, Hoboken, 2008 including ($p_{\text{sat}} = 10 \text{ bar}$): $T_{\text{sat}} = 179.9^\circ\text{C}$, $i_f = 762.81 \text{ kJ/kg}$; ($p = 7 \text{ bar}$, $T = 600^\circ\text{C}$): $i = 3700.2 \text{ kJ/kg}$, $v = 0.5738 \text{ m}^3/\text{kg}$.

ANALYSIS: The steady-flow energy equation, in the absence of work (other than flow work), is

$$\begin{aligned} \dot{m}\left(u + pv + \frac{1}{2}V^2 + gz\right)_{\text{in}} - \dot{m}\left(u + pv + \frac{1}{2}V^2 + gz\right)_{\text{out}} + q &= 0 \\ \dot{m}\left(i + \frac{1}{2}V^2 + gz\right)_{\text{in}} - \dot{m}\left(i + \frac{1}{2}V^2 + gz\right)_{\text{out}} + q &= 0 \end{aligned} \quad (1)$$

while the conservation of mass principle yields

$$V_{\text{in}} = \frac{4\dot{m}}{\rho\pi D^2} = \frac{4 \times 1.5 \text{ kg/s}}{950 \text{ kg/m}^3 \times \pi \times (0.110 \text{ m})^2} = 0.166 \text{ m/s}; \quad V_{\text{out}} = \frac{v4\dot{m}}{\pi D^2} = \frac{0.5738 \text{ m}^3/\text{kg} \times 4 \times 1.5 \text{ kg/s}}{\pi \times (0.110 \text{ m})^2} = 90.6 \text{ m/s}$$

(a) The change in the combined thermal and flow work energy from inlet to outlet:

$$\begin{aligned} E_{i,\text{out}} - E_{i,\text{in}} &= \dot{m}(i)_{\text{out}} - \dot{m}(i)_{\text{in}} = \dot{m}(i)_{\text{out}} - \dot{m}[i_{f,\text{sat}} + c_p(T_{\text{in}} - T_{\text{sat}})] \\ &= 1.5 \text{ kg/s} \times (3700.2 \text{ kJ/kg} - [762.81 \text{ kJ/kg} + 4.3 \text{ kJ/kg} \cdot \text{K} \times (110 - 179.9)^\circ\text{C}]) < \\ &= 4.86 \text{ MW} \end{aligned}$$

where $i_{f,\text{sat}}$ is the enthalpy of saturated liquid at the phase change temperature and pressure.

(b) The change in mechanical energy from inlet to outlet is:

Continued...