

## SOLUTION (1.1)

**Known:** The Segway two-wheeled-self-balancing electric vehicle invented by Dean Kamen and used for short distance personnel transportation reportedly travels at 12.5 mph. The vehicle is controlled and powered with computers and electric motors. Lean forward, you move forward. Lean back and you go backward. Lean the handlebars to the left or right and you turn in that direction—see [www.youtube.com](http://www.youtube.com) for a video. When you need to brake, the motor acts as a dynamometer.

**Find:** Review the design of the Segway and address the question as to whether the Segway conceptually is a “reasonable safe design” using the following categories:

- (1) The usefulness and desirability of the product.
- (2) The availability of other and safer products to meet the same or similar needs.
- (3) The likelihood of injury and its probable seriousness.
- (4) The obviousness of the danger.
- (5) Common knowledge and normal public expectation of the danger (particularly for established products).
- (6) The avoidability of injury by care in use of the product (including the effect of instructions and warnings).
- (7) The ability to eliminate the danger without seriously impairing the usefulness of the product or making it unduly expensive.

### Schematic and Given Data:



**Analysis:** Wikipedia, the free encyclopedia, in an article dated September 4, 2010, entitled “Segway PT,” presents a comprehensive review of the history, sales, technology, uses, operation, and safety of the Segway vehicle.

### Comment:

In what follows, we present segments from the Wikipedia article:

1. History: The product was unveiled December 3, 2001, in Bryant Park on the ABC News morning program *Good Morning America*.
2. Sales: The product was unveiled December 3, 2001, in Bryant Park on the ABC News morning program *Good Morning America*. In a March 2009 interview, company official said the firm “has shipped over 50,000” Segways.
3. Technology: The dynamics of the Segway PT are identical to a classic control problem, the inverted pendulum.

The side effect of this balancing system is that as the Segway PT balances itself the entire unit changes position in the direction it has moved to restore balance. (For example, if the rider leans

forward, the entire Segway PT will move forward from its original position, until the rider restores an upright position on the unit.) This is precisely how the Segway PT is controlled—the balancing and movement is essentially one combined system.

The Segway PT features a governor (speed limiting) mechanism. When the Segway PT approaches the maximum speed allowed by the software, it intentionally begins to tilt slightly backwards. This moves the platform out in front, and leans the handlebars backwards towards the rider, eventually nudging the rider to lean back slightly and slow the Segway PT down. If not for the governor, riders would be able to lean farther than the motor could ever compensate for. The Segway PT also slows or stops immediately if the handlebar of the unit (or forward bag) nudges into any obstacle.

4. Uses: Segways perform best in areas with adequate sidewalks, curb cuts at intersections, and ramps. They are used in cities for tours and in theme parks by visitors and employees. The special police forces trained to protect the public during the 2008 Summer Olympics used the Segway for mobility.

5. Operation: The original Segway models were activated using one of three keys:

*Black Key*: for beginners. Slowest speed (electronically limited to no more than 6 mph); slower turning rate.

*Yellow Key*: for intermediate users and/or pavements. Faster speed—up to 8 mph (13 km/h); faster turning rate.

*Red Key*: for more advanced users in open areas. Maximum speed—up to 10 mph (16 km/h) on p-Series and 12.5 mph (20.1 km/h) on i-Series; and max turning rate.

In September 2003, the Segway PT was recalled because if users ignored repeated low battery warnings on the PTs, it could ultimately lead them to fall. With a software patch to version 12.0, the PT would automatically slow down and stop in response to detecting low battery power. Any units sold before September 2003 with a label 12.0 have the upgraded software.

In August 2006, Segway discontinued all previous models and announced second-generation designs. The Gen II PT, marketed under the two product lines, i2 and x2, allows users to steer by leaning the handlebars to the right or left, which matches the intuitive nature of leaning forward and backward to accelerate and decelerate.

6. Safety: Because the Segway can reach speeds over 20 km/h (12 mph), the Bicycle Helmet Safety Institute recommends that all riders wear helmets when using Segways. The US Consumer Product Safety Commission does not have Segway-specific recommendations but does say that bicycle helmets are adequate for “low-speed, motor-assisted” scooters.

A more exhaustive discussion on the question of whether conceptually the Segway is a “reasonable safe design” is left for the student and/or the instructor. ■

---

## SOLUTION (1.2)

**Known:** Definitions of the words brake, clutch, two-hand control device, die, foot pedal, pinch point, and point of operation are given in 29 CFR 1910.211, which can be located at the website <http://www.osha.gov>.

**Find:** Write definitions for the above words using 29 CFR 1910.211. Identify the defined words (features) on a picture of a power press.

### **Analysis:**

1. Brake means the mechanism used on a mechanical power press to stop and/or hold the crankshaft, either directly or through a gear train, when the clutch is disengaged.
2. Clutch means the coupling mechanism used on a mechanical power press to couple the flywheel to the crankshaft, either directly or through a gear train.
3. Two-hand control device means a two hand trip that further requires concurrent pressure from both hands of the operator during a substantial part of the die-closing portion of the stroke of the press.
4. Die means the tolling used in a press for cutting or forming material. An upper and a lower die make a complete set.
5. Foot pedal means the foot operated lever designed to operate the mechanical linkage that trips a full revolution clutch.
6. Pinch point means any point other than the point of operation at which it is possible for a part of the body to be caught between the moving parts of a press or auxiliary equipment, or between moving and stationary parts of a press or auxiliary equipment, or between the material and moving part or parts of the press or auxiliary equipment.
7. Point of operation means the area of the press where material is actually positioned and work is being performed during any process such as shearing, punching, forming, or assembling.

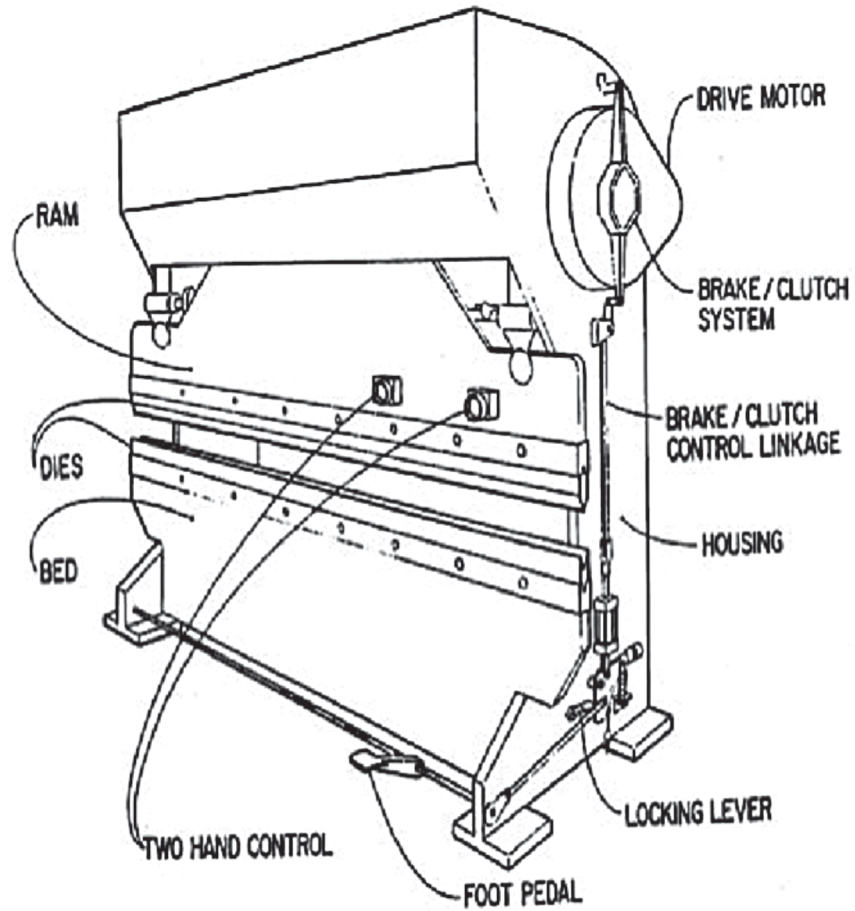

**Comment:** The document 29 CFR 1910.211 provides definitions for numerous power press terms. ■

---

---

## SOLUTION (1.3)

**Known:** 29 CFR 1910.212 contains the general requirements for all machines, and can be located at the website <http://www.osha.gov>.

**Find:** Print a copy of 29 CFR 1910.212 from the website, and locate a picture of a machine that you have used and has a machine guard to protect the operator or others from hazards.

**Analysis:**

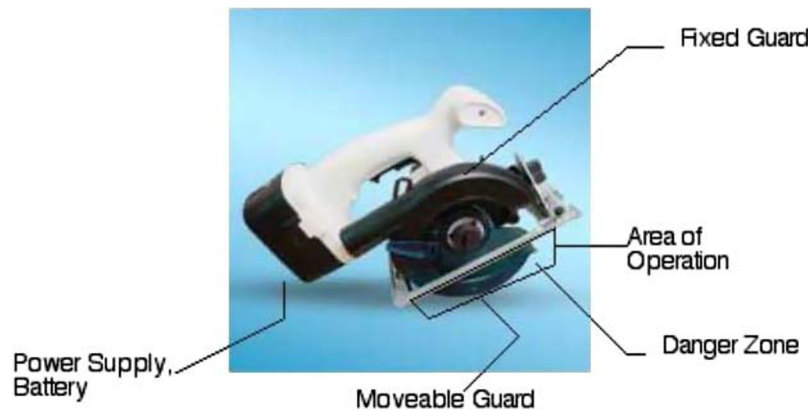

---

## SOLUTION (RP1.1)

**Known:** The OSHA regulations are found at <http://www.osha.gov>.

**Find:** List methods used to guard machine hazards. Give conditions where guards should be used.

**Analysis:** The Code of Federal Regulations, Title 29—Labor, § 1910.212 lists general requirements for all machines:

(a) *Machine guarding—(1) Types of guarding.* One or more methods of machine guarding shall be provided to protect the operator and other employees in the machine area from hazards such as those created by point of operation, ingoing nip points, rotating parts, flying chips and sparks. Examples of guarding methods are—barrier guards, two-hand tripping devices, electronic safety devices, etc.

(2) *General requirements for machine guards.* Guards shall be affixed to the machine where possible and secured elsewhere if for any reason attachment to the machine is not possible. The guard shall be such that it does not offer an accident hazard in itself.

(3) *Point of operation guarding.* (i) Point of operation is the area on a machine where work is actually performed upon the material being processed.

(ii) The point of operation of machines, whose operation exposes an employee to injury, shall be guarded. The guarding device shall be in conformity with any appropriate standards therefore, or, in the absence of applicable specific standards, shall be so designed and constructed as to prevent the operator from having any part of his body in the danger zone during the operating cycle.

(iii) Special handtools for placing and removing material shall be such as to permit easy handling of material without the operator placing a hand in the danger zone. Such tools shall not be in lieu of other guarding required by this section, but can only be used to supplement protection provided.

(iv) The following are some of the machines that usually require point of operation guarding:

- (a) Guillotine cutters.
- (b) Shears.
- (c) Alligator shears.
- (d) Power presses.
- (e) Milling machines.
- (f) Power saws.
- (g) Jointers.
- (h) Portable power tools.
- (i) Forming rolls and calenders.

(4) *Barrels, containers, and drums.* Revolving drums, barrels, and containers shall be guarded by an enclosure which is interlocked with the drive mechanism, so that the barrel, drum, or container cannot revolve unless the guard enclosure is in place.

(5) *Exposure of blades.* When the periphery of the blades of a fan is less than seven (7) feet above the floor or working level, the blades shall be guarded. The guard shall have openings no larger than one-half (1/2) inch.

(b) *Anchoring fixed machinery.* Machines designed for a fixed location shall be securely anchored to prevent walking or moving. ■

---

---

## SOLUTION (RP1.2)

**Known:** An incident occurred on a cattle ranch resulted in an injury to the operator of a tub grinder used to grind hay bales.

**Find:** Search the OSHA regulations at <http://www.osha.gov> and specifically review the regulations 29 CFR 1910.212, *General requirement for all machines*, 29 CFR 1910.147, *The control of hazardous energy (lockout/tagout)*, and 29 CFR 1910.145, *Specifications for accident prevention signs and tags*. Write several paragraphs explaining how each regulation would apply to a tub grinder.

**Analysis:**

1. The OSHA regulations can be obtained by searching the key words: OSHA 1910.212, OSHA 1910.147, and OSHA 1910.145.
2. The exercise of writing several paragraphs on how each regulation applies to a tub grinder is left for the student.

**Comment:** For additional information about this incident, please see the information provided with the following solution. ■

---

---

## SOLUTION (RP1.3)

**Known:** An incident occurred resulting in a worker's hand being amputated in a machine called a "pallet notcher" which cuts notches in 2 in. × 4 in. lumber (boards), used to build pallets. The boards move on a conveyor to the notcher where they drop into a covered area about four feet long. The covered area houses two sets of staggered rotating knives. The boards go through the first set of knives, notching one end, then through the second set which notches the opposite end. At the time of the accident, the worker was collecting the notched wood from the exit area of the machine. He was pulling the boards outward as they exited the machine. He felt something hit his fingertip, and when he pulled back, his hand had been removed near the wrist by one of the sets of knives that notches the 2 in. × 4 in. lumber (boards).

Additional facts in this accident include:

1. Prior to the day of the accident, the employee had not been stationed at the incident pallet notcher.
2. The incident pallet notcher machine was not the employee's usual station.
3. The employee was working near the exit area of the notcher at the time of the accident.
4. The area where the boards exit the machine is approximately 7 inches high and 19 to 20 inches from the point of operation. This distance is easily reachable by an employee working at the machine exit. (OSHA report)
5. A piece of "hung" carpet located toward the exit of the machine hindered the visibility of the blades and allowed an employee to reach under it and access the blades.
6. The pallet notcher was not guarded to protect the employees from the point of operation. (OSHA report)
7. The employer knew that guarding was required and was aware that the pallet notcher was not guarded. (OSHA report)
8. The employee reportedly was not informed of the location of the blades for the incident machine.
9. At the time of the accident, there was not a warning label on the machine to alert the employee that a cutting blade was within his reach.
10. The employee was not instructed to use a pull stick to retrieve boards that do not exit the machine.
11. A 'willful' citation (issued when the employer knowingly commits a violation) was proposed for a violation of 1910.212(a)(3)(ii) (OSHA report)

**Find:** Search the OSHA regulations at <http://www.osha.gov> and specifically review the section 29 CFR 1910.212(a)(3)(ii). Write a paragraph relating the section to the above incident. Also, list ways in which this accident could have been prevented.

### Analysis:

1. The Regulations (Standards – 29 CFR)—Table of Contents—shows:
  - Part Number: 1910
  - Part Title: Occupational Safety and Health Standards
  - Subpart: O
  - Subpart Title: Machinery and Machine Guarding

- Standard Number: 1910.212
- Title: General requirements for all machines.

2. Specifically for 29 CFR **1910.212(a)**: Machine guarding.

**1910.212(a)(1)**

Types of guarding. One or more methods of machine guarding shall be provided to protect the operator and other employees in the machine area from hazards such as those created by point of operation, ingoing nip points, rotating parts, flying chips and sparks. Examples of guarding methods are—barrier guards, two-hand tripping devices, electronic safety devices, etc.

**1910.212(a)(2)**

General requirements for machine guards. Guards shall be affixed to the machine where possible and secured elsewhere if for any reason attachment to the machine is not possible. The guard shall be such that it does not offer an accident hazard in itself.

**1910.212(a)(3)**

Point of operation guarding.

**1910.212(a)(3)(i)**

Point of operation is the area on a machine where work is actually performed upon the material being processed.

**1910.212(a)(3)(ii)**

*The point of operation of machines whose operation exposes an employee to injury, shall be guarded. The guarding device shall be in conformity with any appropriate standards therefore, or, in the absence of applicable specific standards, shall be so designed and constructed as to prevent the operator from having any part of his body in the danger zone during the operating cycle.*

**1910.212(a)(3)(iii)**

Special handtools for placing and removing material shall be such as to permit easy handling of material without the operator placing a hand in the danger zone. Such tools shall not be in lieu of other guarding required by this section, but can only be used to supplement protection provided.

3. This accident could have been prevented if (a) the machine had been properly guarded, (b) a warning label was visible by employees working at the machine exit, and/or (c) the employer had been properly trained and instructed as to the location of the blades.

**Comments:**

1. There was no guard on the machine's exit to prevent an employee from reaching the blades within the machine.
  2. By leaving the machine unguarded, the employer allowed their employees to be at serious risk of injury on the unseen yet reachable blades.
  3. The employer failed to provide a safe workplace. ■
-

---

## SOLUTION (1.4)

**Known:** An incident occurred at the residence of a man wherein he was injured when he reportedly applied sandpaper to a rotating drive belt while attempting to repair an exercise treadmill. The incident treadmill was powered by a 2hp DC motor, and was being “operated” by the man while he was attempting to repair the machine by applying sandpaper to the motor drive V-belt at the time of the accident.

Indeed, he decided to remove the treadmill motor guard so he could better access the underside of the tread belt. He noticed and thought that the motor drive belt had a “sheen”. He then took a roll of sandpaper, started the 2 hp electric motor, and attempted to apply—in the area of an in-running nip point—the sandpaper to the drive belt to remove the “sheen” while the treadmill motor and tread belt was powered and running. His middle finger on his right hand was reportedly drawn with the sandpaper into the motor belt and rotating drive pulley. He sustained injury to his finger as a result of the accident.

**Find:** From your viewpoint, address the issue of whether the incident treadmill was reasonably safe. Also, list possible causes of the accident.

**Analysis:** An analysis would involve an objective review of items (1) to (7) as listed:

### 1. The usefulness and desirability of the product

Product helps promote fitness and general health for users. Allows users to exercise when weather conditions are bad and when time constraints do not allow travel to a gym. Also allows users have a custom tailored workout with precise speed and elevation changes. Product is desirable, as people want to maintain health and fitness and often desire convenience as an incentive.

### 2. The availability of other and safer products to meet the same needs

There are currently treadmills with more guarding on the treadbelt/roller areas but the motor guard design is essentially the same. No other treadmills have a safer motor guard design incorporating tamper resistant screws, guard interlocks, motor guard warnings and/or owner’s manual holders. Some other machines (elliptical trainer, stationary bike, stair stepper) provide similar cardio workouts but they are not as effective at maintaining fitness as treadmills.

### 3. The likelihood of injury and its probable seriousness

The likelihood of injury from placing your hands in and around a high speed rotating nip point is very high and should be protected against. The seriousness of the injury is very high with great probability of serious but not life threatening injury to hands and fingers.

### 4. The obviousness of the danger

The danger of a high speed rotating motor pulley and the drive belt associated is open and obvious. Everyone knows that spinning objects and cause harm (fans, car belts, grinder wheels).

### 5. Common knowledge and normal public expectation of the danger (particularly for established products)

People see treadmills as mostly safe. I believe the public knows that you can fall from a treadmill and then be injured from the moving treadbelt. The public may also be aware of pinch points and friction injury from the moving treadbelt. My thought is that the public would see treadmill as slightly more dangerous than running outside and falling during running is the major cause of injury. I do not believe the public is aware of the danger of the motor pulley and drive belt with the motor guard in place.

6. The avoid ability of injury by care in use of the product (including the effect of instructions or warnings)

The ability to avoid injury is very high when the users keeps the motor guard installed and in place. Warnings on the motor guard may prevent the accident by discouraging some users from disassembly of the motor guard but it is not an assurance. It is less likely that a warning placed inside the motor area would prevent the accident, as the location of the warning would have to be placed away from the hazard. Normal use of the product with the motor guard in place would avoid all potential of the user from being entangled in the motor nip points. If the owner's manual instructions were followed then the accident would have most probably not happened.

7. The ability to eliminate the danger without seriously impairing the usefulness of the product or making it unduly expensive

The danger is easy to eliminate by using a motor guard. The usefulness is not hampered in any way by the inclusion of a guard and does not add a significant cost. The guard also serves a useful cosmetic purpose. The guard could be interlocked and/or installed with tamper resistant bolts that would discourage unauthorized access to the motor area. But this would introduce additional parts that could fail and/or make the treadmill more difficult to maintain. Also, there is no apparent additional means to remove the danger of the motor pulley or drive belt once the user has removed and defeated the guard.

After a reconstruction of the accident and an objective review of the design of the exercise treadmill, the following causes of the accident were identified:

The proximate cause of the accident (incident) was that the owner: (a) attempted to repair the incident treadmill apparently without being qualified, (b) removed the electrical motor cover guard and exposing the drive belt and pulleys, (c) provided electrical power (energized) the treadmill, (d) started the electrical motor and treadmill belt in motion, and/or (e) placed his fingers in an area of an in-running nip point.

A producing cause of the accident was the owner placing his hand in and/or around a known open and obvious danger.

The owner knew or should have known not to attempt to repair a treadmill with the electrical motor cover guard removed, the motor and electrical circuits exposed and energized, the tread belt moving, and the motor belt in operation, while his hand was in the area of an in-running nip point.

The incident treadmill was reasonably safe when it left the hands of the manufacturer.

**Comments:**

A. Additional facts in this case include:

1. The incident treadmill allows the user to walk, jog, or run by means of traversing a continuous moving surface—tread belt. The owner was not using the treadmill for its intended purpose at the time of his injury.
2. The incident treadmill had a motor guard installed over the drive motor and drive belt area. The motor guard prevents the user from being entangled in the in-running nip points of the motor and drive belt.
3. The motor guard was secured to the treadmill with two Phillips pan head machine screws (bolts) and four Allen bolts (socket cap screws).
4. The owner's deposition testimony indicates that he knew of and recognized the danger of removing the guard, and turning on the treadmill, and sanding the motor power belt while it was in operation.

## B. Accident description:

1. The owner was in the process of repairing the incident treadmill prior to the incident made the basis of this case.
2. The owner removed the motor cover (motor guard) for the incident treadmill.
3. The owner examined the motor drive belt and noted a “sheen” on the drive belt.
4. The owner reportedly obtained a 6" length of sandpaper and decided to sand down or remove an apparent “sheen” from the motor drive belt.
5. The owner “plugged in” the treadmill electrical cord into a 120-volt source and also activated the electric motor, motor pulley and the treadmill’s tread belt.
6. The owner then placed his right hand and sandpaper near the in-running nip point of the motor drive belt and drive pulley.
7. The sandpaper the owner was reportedly holding and/or the middle finger of his right hand was/were pulled into the in-running nip point of the drive belt and the incident pulley.
8. The owner injured his right middle finger.

## C. A mechanical engineer that investigated the accident, reconstructed the accident event, and studied the design and operation of the treadmill concluded that:

### Accident event

1. The owner did not have a background, training or experience in treadmill repair and was not a treadmill repair technician.
2. The danger of the exposed in-running nip point between the electric motor drive belt and pulley was open and obvious. The owner knew the danger of the in-running nip point.

### Design

3. It is not the practice in the “industry” to use tamper resistant fasteners for securing the motor cover guard since the motor area needs to be accessible to a variety of technicians.
4. The use of tamper resistant fasteners for securing the motor cover guard in a treadmill is not specified/mentioned in a treadmill related and applicable standard.
- 5a. There was no evidence of a design, manufacturing, and/or marketing defect at the time of manufacture of the treadmill ( $\approx$  1993).
- 5b. There is no evidence that the incident treadmill made the basis of this case did not meet applicable standards at the time of manufacture.
6. The incident treadmill had guarding to prevent treadmill users from being entangled in the motor and drive belt nip points.

### Warnings

7. The incident treadmill control panel contained a warning that stated: **“CAUTION! READ OWNER’S MANUAL CAREFULLY BEFORE OPERATING THIS EQUIPMENT. Keep hands and clothing away from belt and rear roller when in motion. DO NOT ALLOW children or anyone unfamiliar with its operation on or near this treadmill”**.
8. A manual was provided with the incident treadmill.
9. It is not the practice in the “industry” to mount a holder for an owners/operators (instruction) manual on treadmills (consumer or institutional).
10. The manual was subsequently “lost” by the owner.
- 11a. The owner knew or should have known of the dangers of operating the treadmill with the motor running and the motor cover guard removed. A warning of the danger of removing the motor guard while operating the treadmill with the guard removed and the motor running would most probably have not have prevented this accident.
- 11b. The owner assumed the risk of injury in the manner in which he attempted to repair the incident treadmill. ■

---

## SOLUTION (RP1.4)

**Known:** Lockout/tagout procedures are discussed in 29 CFR 1910.147, which can be located at the website <http://www.osha.gov>.

**Find:** Write a paragraph explaining the procedure of lockout/tagout for machines or equipment.

**Analysis:** When service or maintenance is being performed on a machine or equipment it should be locked and tagged out. These service or maintenance activities include lubrication, cleaning, or unjamming of a machine or equipment and making adjustments or tool changes, where the employee may be exposed to the unexpected energization or startup of the equipment or release of hazardous energy. A lockout device, either a key lock or combination lock, must be placed on the energy isolating device locking it into the safe position so that the equipment being controlled cannot be operated until the lockout device is removed. The tagout device should be placed on the isolating device, to indicate that the energy isolating device and the equipment being controlled may not be operated until the tagout device is removed. ■

---

---

## SOLUTION (1.5)

**Known:** Specifications for danger and caution signs are found in 29 CFR 1910.145, which can be located at the website <http://www.osha.gov>.

**Find:** Determine the difference between a danger sign and a caution sign. Determine when the word “warning” should be used.

**Analysis:**

1. Danger signs are to be used only where an immediate hazard exists. Caution signs are to be used only to warn against potential hazards or to caution against unsafe practices.
  2. Warning tags may be used to represent a hazard level between “caution” and “danger,” instead of the required “caution” tag, provided that they have a signal word of “warning,” an appropriate major message, and otherwise meet the general tag criteria. ■
- 

---

## SOLUTION (1.6)

**Comment:** This problem is left as an exercise for the student.

---