

Continuous Dynamics — Exercises

1. A **tuning fork**, shown in Figure 2.1, consists of a metal finger (called a **tine**) that is displaced by striking it with a hammer. After being displaced, it vibrates. If the tine has no friction, it will vibrate forever. We can denote the displacement of the tine after being struck at time zero as a function $y: \mathbb{R}_+ \rightarrow \text{Reals}$. If we assume that the initial displacement introduced by the hammer is one unit, then using our knowledge of physics we can determine that for all $t \in \text{Reals}_+$, the displacement satisfies the differential equation

$$\ddot{y}(t) = -\omega_0^2 y(t)$$

where ω_0^2 is constant that depends on the mass and stiffness of the tine, and where $\ddot{y}(t)$ denotes the second derivative with respect to time of y . It is easy to verify that y given by

$$\forall t \in \text{Reals}_+, \quad y(t) = \cos(\omega_0 t)$$

is a solution to the differential equation (just take its second derivative). Thus, the displacement of the tuning fork is sinusoidal. If we choose materials for the tuning fork so that $\omega_0 = 2\pi \times 440$ radians/second, then the tuning fork will produce the tone of A-440 on the musical scale.

- (a) Is $y(t) = \cos(\omega_0 t)$ the only solution? If not, give some others.

Solution: The following is a solution for any constant α :

$$y(t) = \alpha \cos(\omega_0 t) .$$

- (b) Assuming the solution is $y(t) = \cos(\omega_0 t)$, what is the initial displacement?

SOLUTIONS

Solution: $y(0) = \cos(\omega_0 \times 0) = 1$.

(c) Construct a model of the tuning fork that produces y as an output using generic actors like Integrator, adder, scaler, or similarly simple actors. Treat the initial displacement as a parameter. Carefully label your diagram.

Solution: The following model will do the job:

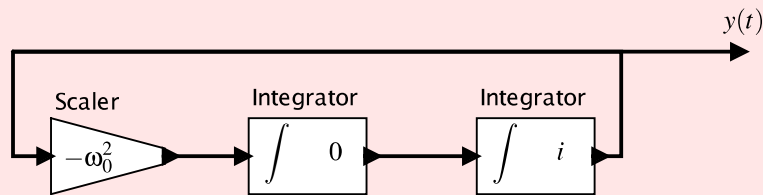

Here, i is the initial displacement.

2. Show that if a system $S: A^{\mathbb{R}} \rightarrow B^{\mathbb{R}}$ is strictly causal and memoryless then its output is constant. Constant means that the output $(S(x))(t)$ at time t does not depend on t .

Solution: Since the system is memoryless, there exists a function $f: A \rightarrow B$ such that for all $x \in X$,

$$(S(x))(t) = f(x(t))$$

We need to show that for all $a_1, a_2 \in A$, $f(a_1) = f(a_2)$.

Since the system is strictly causal, for all $x_1, x_2 \in X$ and $\tau \in \mathbb{R}$,

$$x_1|_{t < \tau} = x_2|_{t < \tau} \Rightarrow S(x_1)|_{t \leq \tau} = S(x_2)|_{t \leq \tau}$$

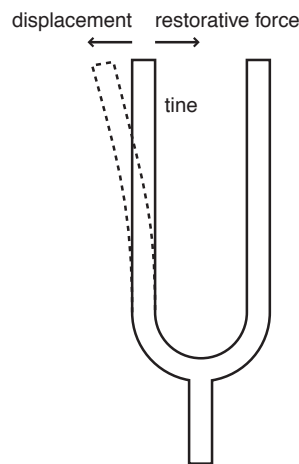

Figure 2.1: A tuning fork.

Using the function f , this becomes

$$x_1|_{t<\tau} = x_2|_{t<\tau} \Rightarrow f(x_1(t)) = f(x_2(t))$$

for all $t \leq \tau$. The left side of this expression imposes no constraint at all on the values of $x_1(\tau)$ and $x_2(\tau)$, so these can be arbitrary values $a_1, a_2 \in A$. Hence, the right hand side asserts that $f(a_1) = f(a_2)$ for all $a_1, a_2 \in A$.

3. This exercise studies linearity.

- (a) Show that the helicopter model defined in Example 2.1 is linear if and only if the initial angular velocity $\dot{\theta}_y(0) = 0$.

Solution: The input T_y and output $\dot{\theta}_y$ are related by

$$\dot{\theta}_y(t) = \dot{\theta}_y(0) + \frac{1}{I_{yy}} \int_0^t T_y(\tau) d\tau.$$

First, we need to show that if $\dot{\theta}_y(0) = 0$, then superposition applies. Then we need to show if $\dot{\theta}_y(0) \neq 0$, superposition does not apply. For the first problem, if $\dot{\theta}_y(0) = 0$ then we have

$$\dot{\theta}_y(t) = \frac{1}{I_{yy}} \int_0^t T_y(\tau) d\tau.$$

Suppose the input is given by

$$T_y = aT_1 + bT_2$$

where a and b are real numbers and T_1 and T_2 are signals. Then the output is

$$\begin{aligned} \dot{\theta}_y(t) &= \frac{1}{I_{yy}} \int_0^t (aT_1(\tau) + bT_2(\tau)) d\tau \\ &= \frac{a}{I_{yy}} \int_0^t T_1(\tau) d\tau + \frac{b}{I_{yy}} \int_0^t T_2(\tau) d\tau. \end{aligned}$$

It is easy to see that the first term is a times what the output would be if the input were only T_1 , and the second term is b times what the output would be if the input were only T_2 . That is, if the system function is S , the output is

$$\dot{\theta}_y(t) = a(S(T_1))(t) + b(S(T_2))(t).$$

Next, assume that $\dot{\theta}_y(0) \neq 0$. With the same input as above, we get the output

$$\begin{aligned}\dot{\theta}_y(t) &= \dot{\theta}_y(0) + \frac{1}{I_{yy}} \int_0^t (aT_1(\tau) + bT_2(\tau)) d\tau \\ &= \dot{\theta}_y(0) + \frac{a}{I_{yy}} \int_0^t T_1(\tau) d\tau + \frac{b}{I_{yy}} \int_0^t T_1(\tau) d\tau.\end{aligned}$$

We can now see that the output is

$$\dot{\theta}_y(t) = a(S(T_1))(t) + b(S(T_2))(t) - \dot{\theta}_y(0),$$

so superposition does not apply.

(b) Show that the cascade of any two linear actors is linear.

Solution: Given an actor with function S_1 and another with function S_2 , the cascade composition is an actor with function $S_1 \circ S_2$, the composition of the two functions. If S_1 and S_2 both satisfy the superposition property, then

$$\begin{aligned}S_2(S_1(ax_1 + bx_2)) &= S_2(aS_1(x_1) + bS_1(x_2)) \\ &= aS_2(S_1(x_1)) + bS_2(S_1(x_2)).\end{aligned}$$

Hence, the composition also satisfies superposition.

(c) Augment the definition of linearity so that it applies to actors with two input signals and one output signal. Show that the adder actor is linear.

Solution: A system model $S: X_1 \times X_2 \rightarrow Y$, where X_1 , X_2 , and Y are sets of signals, is linear if it satisfies the superposition property:

$$\begin{aligned}\forall x_1, x'_1 \in X_1 \text{ and } \forall x_2, x'_2 \in X_2 \text{ and } \forall a, b \in \mathbb{R}, \\ S(ax_1 + bx'_1, ax_2 + bx'_2) &= aS(x_1, x_2) + bS(x'_1, x'_2).\end{aligned}$$

The adder component is given by

$$S(x_1, x_2) = x_1 + x_2.$$

Hence

$$\begin{aligned}S(ax_1 + bx'_1, ax_2 + bx'_2) &= ax_1 + bx'_1 + ax_2 + bx'_2 \\ &= a(x_1 + x_2) + b(x'_1 + x'_2) \\ &= aS(x_1, x_2) + bS(x'_1, x'_2).\end{aligned}$$

4. Consider the helicopter of Example 2.1, but with a slightly different definition of the input and output. Suppose that, as in the example, the input is $T_y: \mathbb{R} \rightarrow \mathbb{R}$, as in the example, but the output is the position of the tail relative to the main rotor shaft. Is this model LTI? Is it BIBO stable?

Solution: In this case, the system can be modeled as a function with two output signals,

$$S: (\mathbb{R} \rightarrow \mathbb{R}) \rightarrow (\mathbb{R} \rightarrow \mathbb{R})^2,$$

where

$$(S(T_y))(t) = (x(t), z(t)),$$

where $(x(t), z(t))$ is the position of the tail in the x - z plane. This model is clearly not linear. If the input torque doubles, for example, the output values will not double. In fact, the output values are constrained to lie on a circle centered at the origin, regardless of the input. For this reason, the model is BIBO stable. The output is always bounded. Thus, while our previous model was linear and unstable, this one is nonlinear and stable. Which model is more useful?

5. Consider a rotating robot where you can control the angular velocity around a fixed axis.
- (a) Model this as a system where the input is angular velocity $\dot{\theta}$ and the output is angle θ . Give your model as an equation relating the input and output as functions of time.

Solution:

$$\forall t \in \mathbb{R}, \quad \theta(t) = \theta(0) + \int_0^t \dot{\theta}(\tau) d\tau,$$

where $\theta(0)$ is the initial position.

- (b) Is this model BIBO stable?

Solution: The model is not BIBO stable. For example, the bounded input

$$\dot{\theta}(t) = u(t)$$

is bounded by yields an unbounded output.

- (c) Design a proportional controller to set the robot onto a desired angle. That is, assume that the initial angle is $\theta(0) = 0$, and let the desired angle be $\psi(t) = au(t)$. Find the actual angle as a function of time and the proportional controller feedback gain K . What is your output at $t = 0$? What does it approach as t gets large?

Solution: A proportional controller has the same structure as the helicopter controller:

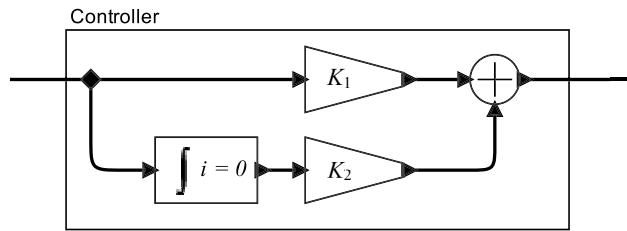
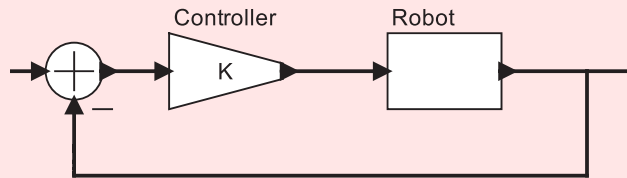

Figure 2.2: A PI controller for the helicopter.



Just as with the helicopter controller, we can solve the integral equation to get

$$\theta(t) = au(t)(1 - e^{-Kt}).$$

The output at zero is $\theta(0) = 0$, as expected. As t gets large, the output approaches a .

6. (a) Using your favorite continuous-time modeling software (such as LabVIEW, Simulink, or Ptolemy II), construct a model of the helicopter control system shown in Figure 2.4. Choose some reasonable parameters and plot the actual angular velocity as a function of time, assuming that the desired angular velocity is zero, $\psi(t) = 0$, and that the top-rotor torque is non-zero, $T_t(t) = bu(t)$. Give your plot for several values of K and discuss how the behavior varies with K .

Solution: A Ptolemy model for the P controller is shown below:

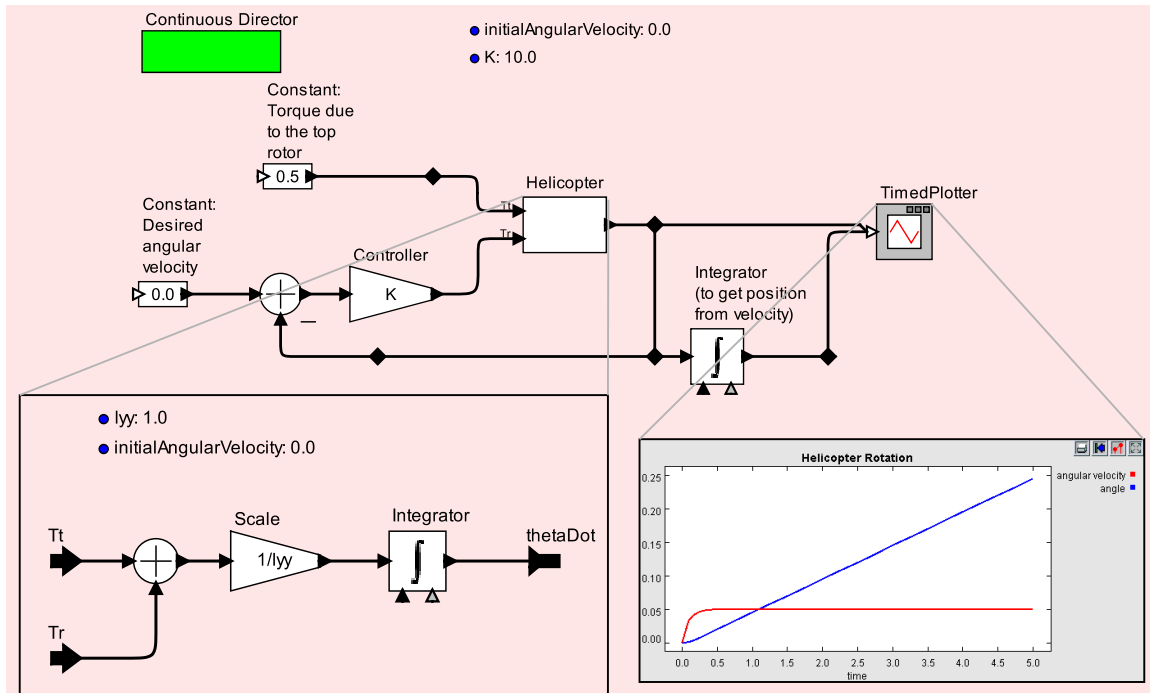

With the controller gain set to $K = 10$ and the top-rotor torque at $T_t(t) = 0.5u(t)$, we see that the angular velocity settles quickly to a constant $0.05 = 0.5/K$. Increasing K to 100 reduces this steady-state error to 0.005. Since the steady state error is in the angular velocity, the angle of the helicopter slowly increases (i.e., the helicopter rotates despite a desired angular velocity of zero).

- (b) Modify the model of part (a) to replace the Controller of Figure 2.4 (the simple scale-by- K actor) with the alternative controller shown in Figure 2.2. This alternative controller is called a **proportional-integrator (PI) controller**. It has two parameter K_1 and K_2 . Experiment with the values of these parameters, give some plots of the behavior with the same inputs as in part (a), and discuss the behavior of this controller in contrast to the one of part (a).

Solution: A Ptolemy model for the PI controller is shown below:

SOLUTIONS

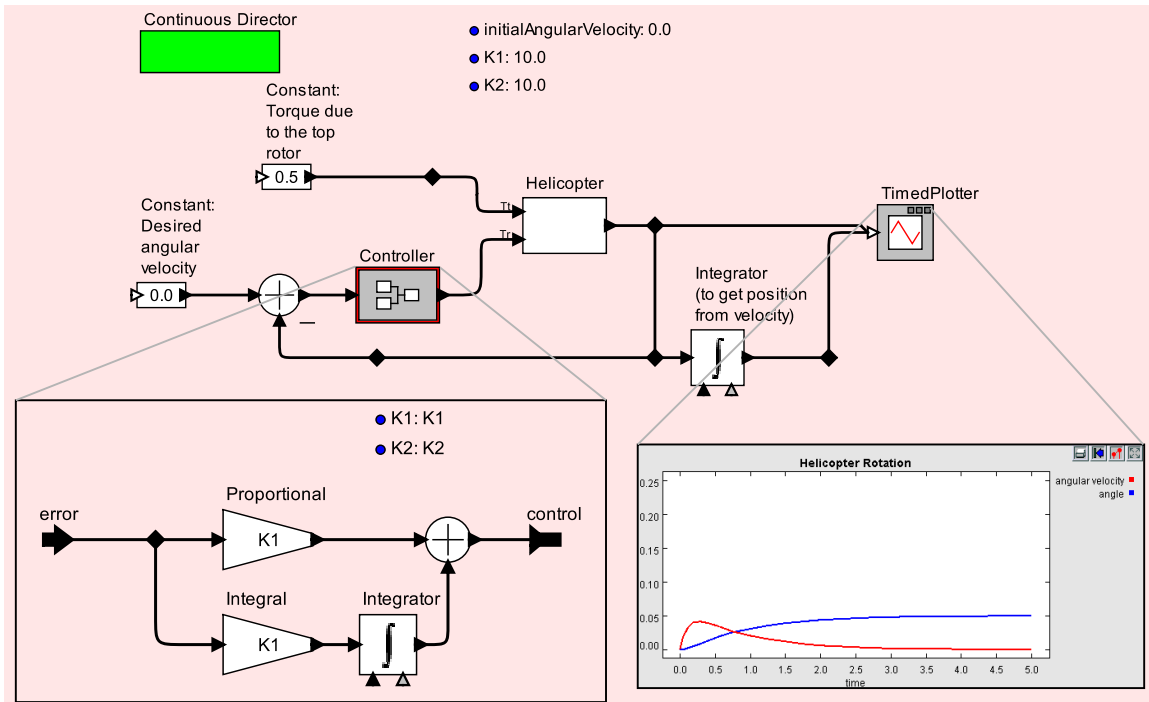

With the controller gains set to $K_1 = 10$ and $K_2 = 10$ and the top-rotor torque at $T_t(t) = 0.5u(t)$, we see that the angular velocity settles eventually to zero. Increasing K_1 results in a smaller peak error. Increasing K_2 results in fast settling, but also some overshoot.