

Problems (Solutions Manual)

PART I

Chapter 1

Questions

1. What are the principal phases of the product design and development process? (Find the answer in Section 1.2)
2. What are the principal activities used during the design phase and at which level of the product defining do they come out? (Find the answer in Section 1.3)
3. What are the differences between sequential model and simultaneous/integrated model of the product development process? Which factors do push toward the diffusion of the second one? (Find the answer in Section 1.5)
4. What is the *Concurrent Engineering*? Which are the characteristic points? (Find the answer in Section 1.5)
5. What is the *Life Cycle Design*? Which are the characteristic points? Which is the relation to Concurrent Engineering? (Find the answer in Section 1.6)
6. What is DFX approach? (Find the answer in Section 1.7)
7. Which are the better known DFXs? (Find the answer in Section 1.7.1)
8. What is Knowledge Based Engineering? (Find the answer in Section 1.9.1)
9. What is Total Quality Management in product design? (Find the answer in Section 1.9.2)
10. What is Reverse Engineering? How it could be integrated in the product development process? (Find the answer in Section 1.9.3)

Chapter 2

Questions

1. What is the *Design for Environment*? Which are the goals? Which are the peculiar characteristics in the approach to design? (Find answer in section 2.3)
2. Which are the most common rules in the design? (Find answer in section 2.5)
3. What are the principal phases of the life cycle of a product? (Find answer in section 2.6)
4. Which are the principal factors that determine the impact of product life cycle phases on the environment? (Find answer in section 2.7)
5. What is the *Life Cycles Assessment*? Which are its goals? (Find answer in section 2.9)
6. Which are the steps for LCA application procedure? (Find answer in section 2.9.1)
7. What are eco-indicators? (Find answer in section 2.9.2)
8. Which are the principal environmental strategies to be applied in the product design for environment process? (Find answer in section 2.13)
9. Which are the main recovery strategies at end of useful life? How could their potential for environmental benefit be differentiated? (Find answer in section 2.13.2)
10. What is the role of the DFX in the Design for Environment process? (Find answer in section 2.15)

PART II

Chapter 3

Question 1

What is the percentage of carbon in a cast iron and what is the percentage of carbon in a steel?

Answer

In the cast Iron varied from 2.06% to 6.67% in the steel varied from 0.008% to 2.06%"

Question 2

Which are the more used cast iron in the mechanical construction, and why?

Answer

The cast iron commonly used is the spheroidal cast iron, it has a good resistance to tensile stress and in comparison to the other kinds of cast iron, it has a good fatigue resistance. For this structure it is less sensitive to notches

Question 3

Which are the chemical elements that give more heat resistance to the stainless steel?

Answer

Two characteristic elements able to give more heat resistance to the stainless steel are Titanium (Ti) and Molybdenum (Mo)

Question 4

What is the characteristic chemical element for a springs alloyed steel?

Wich is the effect of this element for the mechanical characteristics of these steels?

Answer

One typical element for the spring steels is silicon (Si). This element makes the steel to have a yield limit near the ultimate limit with a laminated plastic deformation. This characteristic is useful for this kind of steel

Question 5

What are the two chemical base elements of the bronzes? What is the chemical element able to increase their anti-friction and workability properties?

Answer

The two base elements are Copper (Cu) and Tin (St).
Lead is the chemical element able that gives bronze alloys anti-friction and workability.

Question 6

According to the temperature effects, how can be classified the polymeric materials? What are the differences in terms of workability?

Answer

According to the temperature effects the polymeric materials they can be classified as:
Thermoplastic materials and Thermosetting materials.

The firsts become plastic by heating and are hot-working. The seconds, after heating, return hard and they cannot be altered.

Question 7

One parameter used to qualify a material is the ratio between the Failure tensile stress and the specific gravity (specific strength). Make a confrontation of this parameter between an AISI 4340 steel, a high-strength carbon fiber and an aluminium alloy AL7178-T6

Answer

For the three materials, the failure tensile stress is respectively: 1722 MPa, 1550 MPa and 606 MPa.

The specific gravity is respectively 7.87, 1.55 and 2.70.

The specific strength is respectively 22.3, 101.9, 22.9 (see table page 74).

It is evident as this parameter (specific strength) is confrontable for aluminium alloy and steel alloy but they have a value 5 times less than the carbon fiber.

It is to remember that normally the steel alloys have a unit strain more high than the other two materials.

Chapter 4

Problem 1

Being as M_t the torque and L the length, calculate the diameter and evaluate the *material quality index* for a cylindrical twisting shaft if the target is to minimize the mass.

Solution

In this problem the target is to minimize the weight of the torsion shaft, the constrain is the value of the torsion strength, the variable is the diameter $2r$. The target function is:

$$m = \pi r^2 L \rho$$

The maximum torsion stress (chapter 13) for the application of a torque moment M_t is:

$$\tau = \frac{M_t r}{J}$$

Being that the polar second moment of area $J = \frac{\pi r^4}{2}$, we have:

$$\tau = \frac{2M_t}{\pi r^3}$$

For a material that has to assure the strength structural, it must be:

$$\frac{\tau_f}{S} = \frac{2M_t}{\pi r^3} \quad (S \text{ is an adequate factor of safety})$$

From this formula it is possible to find the free variable r as

$$r = \left(\frac{2SM_t}{\pi \tau_f} \right)^{1/3}$$

By substitution of this in the target function, we have:

$$m = (2SM_t)^{2/3} \left(\pi^{1/3} L \right) \left(\frac{\rho}{\tau_f^{2/3}} \right)$$

and the efficiency index of the material is defined by $\tau_f^{2/3} / \rho$. Therefore the best solution is given by that material which is able to maximize this index.

Problem 2

For a specimen beam of length $L = 175$ mm (see Figure A.4.1A) choose the positions of the constraints and the load system to have a pure and symmetrical bending on the central zone of the beam. Evaluate the applied load to have a maximum stress σ equal to 200 N/mm^2

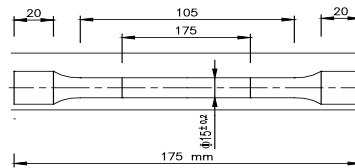

FIGURE A.4.1A

Solution

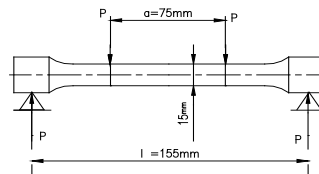

FIGURE A.4.1B

With the loads as indicated in figure A.4.1B, the pure bending moment is $M = P(l-a)/2$ constant from S_1 to S_2 . The stress on this part is $\sigma = M/W = P(l-a)/(2W)$ and therefore:

$$P = 2W \sigma / (l-a) = 2 \pi d^3 / [(l-a)32] = 2 \times 500 \times 15^3 / (40 \times 32) = 1054,69 \text{ N}$$

Problem 3

For a cylindrical fixed beam of length $l = 500$ mm, $d = 10$ mm as in figure A.4.2A, choose a load system and the constraints to have a pure torsion on the beam. Evaluate the applied load necessary to have a maximum value of the angular deformation $\theta = 1^\circ$. Assume the shear modulus $G = 83.000 \text{ N/mm}^2$

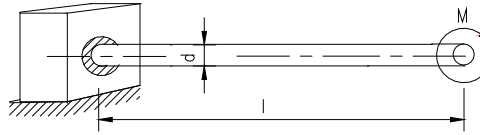

FIGURE A.4.2A

Solution

To have pure torsion it is necessary to apply a pure torque. This is possible loading the beam as in figure A.4.2B.

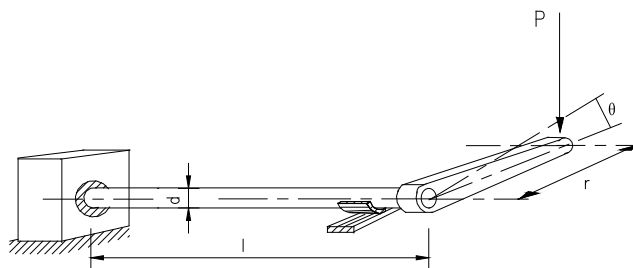

FIGURE A.4.2B

In this way the only stress on the beam is a torsion stress.

The torque on the beam is $M = P r$.

The angular deformation in this case is: $\theta = \frac{l P r}{G J_p}$. (J_p is the polar second moment of area

$$J_p = \pi d^4 / 32 = 981.25 \text{ mm}^4$$

We can fix P or r to have the data deformation. Fixing $r = 100 \text{ mm}$ to have a $\theta = 1^\circ$ (0.1744 rad.) the to

$$\text{applied load must be: } P = \frac{\theta G J_p}{l r} = \frac{0.1744 \times 83.000 \times 981,25}{500 \times 100} = 284 \text{ N}$$

Problem 4

Consider a torsion bar 0.45 m in length with a circular section (diameter is 22 mm) as reported in Figure A.4.3; r is 150 mm. Determine the maximum deflection in the P direction that arises as a result of the load P equal to 1.2 kN. Neglect the bending deflection of the connecting rod. The modulus of elasticity $E= 200.000\text{N/mm}^2$ and the shear modulus G is 70000 N/mm^2 .

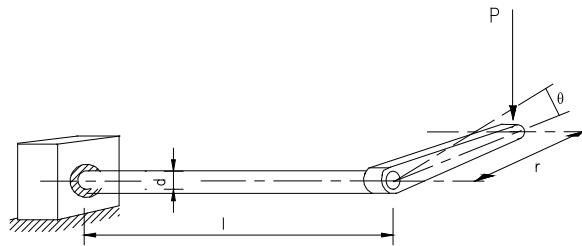

FIGURE A.4.3

Solution

With reference to the schema in Figure 1, in general, the deflection will be the sum of the contribution of bending and torsion of the bar, so it will be:

$$f = f_f + f_t$$

The deflection due to bending is given by:

$$\text{The second moment of area is } J = \pi d^4 / 64 = 3.14 \times 22^4 / 64 = 11.493,18 \text{ mm}^4$$

$$\text{And the polar second moment of area is } J_p = 2J = 22.986,36 \text{ mm}^4$$

$$W = 2J/d = 1044.83 \text{ mm}^3$$

$$\sigma = M/W = 516.83$$

$$f_f = \frac{Pl^3}{3EJ} = 1200(450)^3 / (3 \times 200.000 \times 11.493,18) = 15.85 \text{ mm}$$

The angular deformation due to torsion is given by:

$$\theta = \frac{Pr}{GJ_p} \text{ and therefore the deflection is: } f_t = l\theta = 1200 \times 150 \times 450 / (70000 \times 22986.36) = 0.05 \text{ mm}$$

negligible in confrontation to the bending deflection.

Problem 5

The cylindrical bar constrained as in figure A.4.3A has a length $l = 1.2\text{m}$ and diameter $d=0.03\text{m}$. For a test, was applied a load $P = 200\text{ N}$ at the end of the bar as in figure (r=0.30m). It was found that the ratio between the angular torsion Θ and the angular deflection α was 0,62. Calculate the modulus of Poisson $\nu=1/m$

Solution

Applying the theorems of ellipse of elasticity (see page 290 of the book) we have:

$$\alpha = Pl^2 / (2EJ) \text{ and } \Theta = Prl / (GJ_p) \text{ from which}$$

$$E/G = (\Theta l) / (\alpha r) = 1200 \times 0,62 / 300 = 2.48.$$

$$\text{Being } m = 2 / ((E/G) - 2) = 4.17, \text{ will be } \nu = 1/m = 0,24$$

Problem 6

The Brinell hardness HB for a test on 10 specimens of a steel gave this results: 195, 203, 205, 198, 198, 201, 203, 200, 197, 197. Calculate the average value and the standard deviation. Estimate the value of the ultimate stress R_m of the steel.

Solution

Remembering that the for n elements x_i the sample mean $x^* = \sum_i x_i / n = 1997 / 10 = 199.7$ and that the standard deviation is: $d = (\sum_i (x_i - x^*)^2 / (n - 1))^{1/2} = 3.23$, the estimate value of the ultimate stress R_m can be find as $R_m = 0.346 HB = 69.10$

Problem 7

Consider a metal sheet obeying the von Mises criteria, with the following yield stress: $\sigma_{Eq-0} = 65\text{MPa}$ and the following constitutive curve: $\sigma_{Eq}(\epsilon_{Eq}) = 65 + 200 \cdot \epsilon_{Eq}^{0.3}$ As in Figure A.4.4, the sheet is gradually loaded by two uniform tensile stresses, in the x direction up to 120 MPa and in the y direction up to 150 MPa;

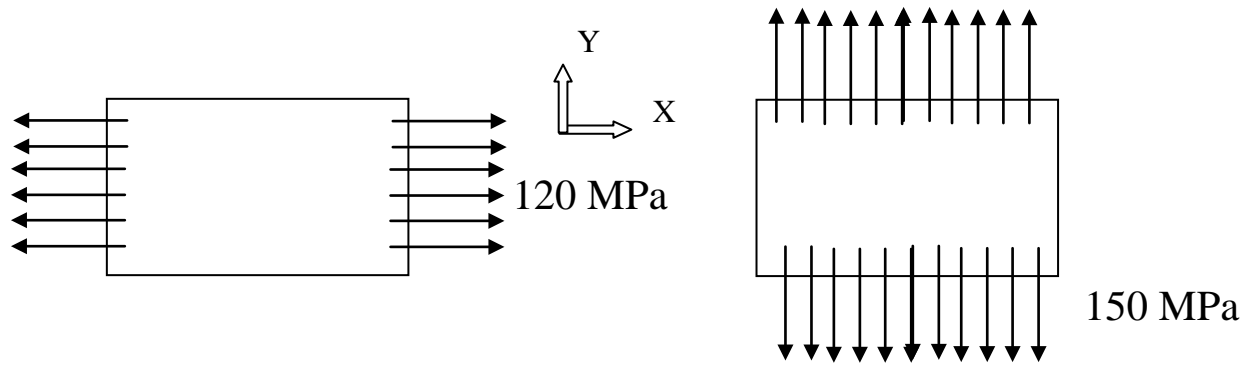

FIGURE A.4.4A

Determine the equivalent plastic strain of the plate at end of the two stress sequences. The elastic strains can be neglected, and plastic strains can be assumed to be infinitesimal.

Solution