

# Chapter 1

1.1 From Eq. (1.1)

$$V_{LSB} = \frac{V_{FS}}{2^n} = \frac{3.5}{2^8} = 136.7 \text{ mV}$$

1.2 From Eq. (1.1)

$$V_{LSB} = \frac{V_{FS}}{2^n} = \frac{5}{2^{16}} = 76 \text{ mV}$$

1.3 From Eq. (1.1)

$$V_{LSB} = \frac{V_{FS}}{2^n} = \frac{3.5}{2^{16}} = 53.4 \text{ } \mu\text{V}$$

1.4 From Eq. (1.2)

$$v_o = (1x2^{-1} + 0x2^{-2} + 1x2^{-3})x5 = (0.5 + 0.125)x5 = 0.625x5 \text{ V}$$

$$v_o = 3.125 \text{ V}$$

1.5 From Eq. (1.2)

$$v_o = (1x2^{-1} + 1x2^{-2} + 0x2^{-3} + 1x2^{-4})x5 \text{ V}$$

$$v_o = (0.5 + 0.25 + 0.125)x5 \text{ V} = 4.375 \text{ V}$$

1.6

$$v_{AB} = 6.5 + 5x10^{-3} \text{ Sin } 200\pi t$$

$$V_{DC} = 6.5 \text{ V}$$

$$I_{DC} = \frac{V_{DC}}{R_L} = \frac{6.5}{1\text{K}\Omega} = 6.5 \text{ mA}$$

$$v_{ab} = 5x10^{-3} \text{ Sin } 200\pi t \text{ V}$$

$$i_a = \frac{v_{ab}}{R_L} = \frac{5x10^{-3} \text{ Sin } 200\pi t}{1\text{K}\Omega} = 5x10^{-3} \text{ Sin } 200\pi t \text{ mA}$$

$$v_{AB} = 6.5 + 5x10^{-3} \text{ Sin } 200\pi t \text{ V}$$

$$V_{ab} = \sqrt{6.5^2 + \left(\frac{5x10^{-3}}{\sqrt{2}}\right)^2} \approx 6.5 \text{ V}$$

$$I_a = \sqrt{6.5^2 + \left(\frac{5x10^{-3}}{\sqrt{2}}\right)^2} \text{ mA} \approx 6.5 \text{ mA}$$

1.7

Given

$$v_{DC} = 7.5 + 10 \times 10^{-3} \sin 2000 \pi t \text{ V}$$

$$V_{DC} = 7.5 \text{ V}$$

$$I_{DC} = \frac{V_{DC}}{R_L} = \frac{7.5}{1 \text{ K}\Omega} = 7.5 \text{ mA}$$

$$v_{ab} = 10 \times 10^{-3} \sin 2000 \pi t$$

$$i_a = \frac{10 \times 10^{-3} \sin 2000 \pi t}{1 \text{ K}} = 10 \times 10^{-3} \sin 2000 \pi t \text{ mA}$$

$$V_{ab} = \sqrt{(7.5)^2 + \left(\frac{10 \times 10^{-3}}{\sqrt{2}}\right)^2} \approx 7.5 \text{ V}$$

$$i_A = 7.5 \text{ mA} + 10 \times 10^{-3} \sin 2000 \pi t \text{ mA}$$

$$I_a = \sqrt{(7.5)^2 + \left(\frac{10 \times 10^{-3}}{\sqrt{2}}\right)^2} \text{ mA}$$

$$I_a \approx 7.5 \text{ mA}$$

1.8

$$v_s = 1.5 + 12 \times 10^{-3} \sin \omega t \text{ V}$$

$$v_o = 7.5 + 2.5 \sin \omega t \text{ V}$$

From Eq. (1.9)

$$A_v = \frac{7.5}{1.5} = 5$$

From Eq. (1.10)

$$A_v = \frac{2.5}{12 \times 10^{-3}} = 208.3$$

1.9

$$v_s = 2.5 + 20 \times 10^{-3} \sin \omega t$$

$$v_o = 7.5 + 4.5 \times 10^{-3} \sin \omega t$$

From Eq. (1.9)

$$A_v = \frac{7.5}{2.5} = 3$$

From Eq. (1.10)

$$A_v = \frac{4.5}{20 \times 10^{-3}} = 225$$

1.10

(a)

From Eq. (1.12)

$$\text{Power gain } A_p = \frac{P_L}{P_i} = \frac{\frac{v_o^2}{R_L}}{\frac{v_s^2}{R_i}} = \frac{1/100 \text{ K}\Omega}{(40 \times 10^{-3})^2 / 50 \text{ K}\Omega} = 312.5$$

(b) For  $R_L = R_i = 50 K\Omega$

$$A_p = \frac{P_L}{P_i} = \frac{v_o^2}{v_s^2} = \frac{1}{(40 \times 10^{-3})^2} = 625$$

From Eq. (1.11)

$$A_i = \frac{i_o}{i_s} = \frac{v_o/R_L}{v_s/R_i} = \frac{1}{40 \text{ mV}} = 25$$

### 1.11

(a)

From Eq. (1.12)

$$A_p = \frac{v_o^2/R_L}{v_s^2/R_i} = \frac{1.2^2/147 K\Omega}{(80 \times 10^{-3})^2/100 K\Omega} = 153$$

(b)

$R_L = R_i = 100 K\Omega$

$$A_i = \frac{v_o/R_L}{v_s/R_i} = \frac{1.2}{80 \times 10^{-3}} = 15$$

### 1.12

(a)

$$A_v = \frac{v_{o(\text{peak})}}{v_{i(\text{peak})}} = \frac{6.5}{50 \times 10^{-3}} = 1.30 \times 10^3 = 130 \text{ or } 42.28 \text{ dB}$$

$$i_o = \frac{v_o}{R_L} = \frac{6.5 \sin 1000 \pi t}{5000} = 1.3 \sin (1000 \pi t) \text{ mA}$$

$$A_i = \frac{i_{o(\text{peak})}}{i_{L(\text{peak})}} = \frac{1.3 \times 10^{-3}}{1 \times 10^{-6}} = 1300 \text{ or } 62.28 \text{ dB}$$

$$A_p = A_v \cdot A_i = 130 \times 1300 = 169 \times 10^3 \text{ or } 52.28 \text{ dB } (10 \log P_o/P_i)$$

$$R_i = \frac{v_{i(\text{peak})}}{i_{i(\text{peak})}} = \frac{50 \times 10^{-3}}{1 \times 10^{-6}} = 50 \text{ k}\Omega$$

(b)

$$P_{dc} = V_{CC} I_{CC} + V_{EE} I_{EE} = 15 (15 + 15) \text{ mW} \\ = 450 \text{ mW}$$

$$P_L = \frac{v_{o(\text{peak})}}{\sqrt{2}} \cdot \frac{i_{o(\text{peak})}}{\sqrt{2}} = \frac{6.5 \times 1.3 \times 10^{-3}}{2} \\ = 4.225 \text{ mW}$$

$$P_i = \frac{v_{i(\text{peak})}}{\sqrt{2}} \cdot \frac{i_{i(\text{peak})}}{\sqrt{2}} = \frac{50 \times 10^{-3} \times 1 \times 10^{-6}}{2} = 25 \text{ nW}$$

$$\eta = \frac{P_L}{P_{dc} + P_1} = \frac{4.225 \times 10^{-3}}{450 \times 10^{-3} + 25 \times 10^{-9}} \approx 0.938\%$$

(c)  $A_v v_{i(\max)} = V_{o(\max)} = V_{CC}$

$$v_{i(\max)} = \frac{15}{130} = 115.4 \text{ mV}$$

### 1.13

$$V_o = 5.3 \text{ V at } V_1 = 21 \text{ mV, } V_o = 5.8 \text{ V at } V_1 = 27 \text{ mV}$$

$$\Delta V_o = 5.8 - 5.3 = 0.5 \text{ V, } \Delta V_1 = 27 - 21 = 6 \text{ mV}$$

(a)  $A_v = \frac{\Delta V_o}{\Delta V_1} = \frac{0.5}{6 \times 10^{-3}} = 83.3 \text{ or } 38.4 \text{ dB}$

(b)  $A_{dc} = \frac{V_o}{V_1} = \frac{5.5}{24 \times 10^{-3}} = 229 \text{ or } 47.2 \text{ dB}$

(c)  $\frac{V_o - V_{(\min)}}{A_v} \leq V_F - 24 \text{ mV} \leq \frac{V_{o(\max)} - V_o}{A_v}$

$$\frac{-5.5 + 2}{83.3} \leq V_1 - 24 \text{ mV} \leq \frac{11 - 5.5}{83.3}$$

$$-42 \text{ mV} \leq V_1 - 24 \text{ mV} \leq 66 \text{ mV}$$

$$-18 \text{ mV} \leq V_1 \leq 90 \text{ mV}$$

### 1.14

(a)  $i_o = \frac{v_o}{R_L} = \frac{2 \text{ V}}{10 \text{ k}\Omega} = 0.2 \text{ mA}$

$$i_i = \frac{v_i}{R_1} = \frac{1 \text{ mV}}{100 \text{ k}\Omega} = 10 \text{ nA}$$

$$A_i = \frac{i_o}{i_i} = \frac{0.2 \times 10^{-3}}{10 \times 10^{-9}} = 2 \times 10^4 \text{ or } 86 \text{ dB}$$

$$A_v = \frac{v_o}{v_i} = \frac{2}{1 \times 10^{-3}} = 2 \times 10^3$$

$$A_p = A_v A_i = 2 \times 10^3 \times 2 \times 10^4 = 4 \times 10^7 \text{ or } 152 \text{ dB}$$

(b)  $v_i = i_i R_1 = 1 \times 10^{-3} \times 100 = 10^{-1} \text{ V}$

$$v_o = i_o R_L = 100 \times 10^{-3} \times 10^3 = 100 \text{ V}$$

$$A_v = \frac{v_o}{v_i} = \frac{100}{0.1} = 1000 \text{ or } 60 \text{ dB}$$

$$A_i = \frac{i_o}{i_i} = \frac{100 \times 10^{-3}}{10^{-3}} = 100 \text{ or } 40 \text{ dB}$$

$$A_p = A_v A_i = 1000 \times 100 = 10^5 \text{ or } 50 \text{ dB}$$

### 1.15

(a) From Eq. (1.23)

$$A_v = \frac{A_{vo}}{(1 + R_s/R_i)(1 + R_o/R_L)}$$

$$= \frac{150}{(1 + 200/1800)(1 + 50/4700)} = 133.6$$

From Eq. (1.24)

$$A_i = \frac{A_{vo} R_i}{R_L + R_o} = \frac{150 \times 1800}{4700 + 50} = 56.84$$

From Eq. (1.25)

$$A_p = A_v A_i = 133.6 \times 56.84 = 7593.82$$

(b) Problem 1.15 Amplifier

```

VS      1  0  AC  100MV
RS      1  2  200
RI      2  0  1.8K
E1      3  0  2  0  150
R0      3  4  50
RL      4  0  4.7K
. TF    V(4) VS
. End

```

### 1.16

For maximum power transfer

$$R_o = R_L = 50 \Omega$$

$$P_L = v_o i_o$$

$$= (A_v v_i) (A_i i_i)$$

$$= \frac{A_{vo} \cdot v_i}{(1 + R_s/R_i)(1 + R_o/R_L)} \cdot \frac{A_{vo} R_i}{R_L + R_o} i_i$$

$$= \frac{A_{vo}^2 R_i R_L v_i}{(R_i + R_s)(R_L + R_o)} \cdot \frac{A_{vo} \cdot v_i}{(R_L + R_o)}$$

$$= \frac{A_{vo}^2 R_i R_L}{(R_L + R_o)^2 (R_i + R_s)} \cdot v_i^2$$

$$= \frac{A_{vo}^2 R_i R_L}{(R_L + R_o)^2 (R_i + R_s)} \cdot \frac{R_i^2 v_s^2}{(R_i + R_o)^2}$$

$$= \frac{A_{vo}^2 R_L R_i^3 v_s^2}{(R_L + R_o)^2 (R_i + R_s)^3}$$

$$\therefore P_{L(\max)} = \frac{150^2 \times 50 \times 1800^3 (100 \times 10^{-3})^2}{100^2 (1800 + 200)^3}$$

$$= 820 \text{ mW}$$

**1.17**

$$\frac{\Delta v_o}{v_o} = \frac{R_o}{R_L + R_o}$$

$$\frac{\Delta v_o}{v_o} = 0.15 = \frac{R_o}{1.5 \text{ k} + R_o}$$

$$R_o = \frac{1.5 \times 10^3 \times 0.15}{0.85} = 264.7 \Omega$$

**1.18**

$$\begin{aligned} \text{(a)} \quad v_o &= A_{vo} v_i \frac{R_L}{R_L + R_o} = A_{vo} \frac{R_L}{R_L + R_o} \cdot \frac{R_i \cdot V_s}{R_i + R_s} \\ &= \frac{200 \times 22 \times 10^5 \times 50 \times 10^{-3}}{(22 + 20)(10^5 + 1500)} = 5.16 \text{ V} \end{aligned}$$

**(b)** From Problem 1.16

$$\begin{aligned} P_L &= \frac{A_{vo}^2 R_L R_i^3 V_s^2}{(R_L + R_o)^2 (R_i + R_s)^3} \\ &= \frac{200^2 \times 22 \times 10^{15} \times (50 \times 10^{-3})^2}{(22 + 20)^2 \cdot (10^5 + 1500)^3} \\ &= 1.19 \text{ W} \end{aligned}$$

$$\text{(c)} \quad A_v = \frac{v_o}{v_s} = \frac{5.16}{50 \times 10^{-3}} = 103.2$$

$$\text{(d)} \quad A_i = \frac{i_o}{i_s}, \quad i_o = \frac{5.16}{22 + 20} = 122.86 \text{ mA}$$

$$i_s = \frac{v_s}{R_s + R_i} = \frac{50 \times 10^{-3}}{1500 + 10^5} = 4.93 \times 10^{-7} \text{ A}$$

$$A_i = \frac{122.86 \times 10^{-3}}{4.93 \times 10^{-7}} = 249 \times 10^3$$

$$\begin{aligned} \text{(e)} \quad A_p &= A_v A_i = 103.2 \times 249 \times 10^3 \\ &= 25.7 \times 10^6 \end{aligned}$$

**1.19**

$$i_s \leq 1 \mu\text{A} = \frac{v_s}{R_s + R_i} = \frac{10 \times 10^{-3}}{2.5 \text{ k} + R_i}$$

$$R_i \geq 7500 \Omega$$

From Eq. (1.27)

$$\frac{\Delta v_o}{v_o} = \frac{R_o}{R_L + R_o}, \quad R_L \text{ ranging from } 2 \text{ k}\Omega \text{ to } 10 \text{ k}\Omega$$

For  $\frac{\Delta v_o}{v_o} \leq 0.5\%$

$$\frac{5}{1000} = \frac{R_o}{R_L + R_o}, \quad R_o \leq 10 \Omega$$

$$A_v = \frac{5 \text{ V}}{10 \text{ mV}} = 500 \text{ or } 53.98 \text{ dB}$$

From Eq. (1.23)

$$500 = \frac{A_{vo}}{(1 + R_s/R_i)(1 + R_o/R_L)} = \frac{A_{vo}}{(1 + 2.5 \text{ k}/7.5 \text{ k})(1 + 10/2000)}$$

$$\therefore A_{vo} = 669.8$$

### 1.20

From Eq. (1.23)

$$A_v = \frac{A_{vo}}{(1 + R_s/R_i)(1 + R_o/R_L)}$$

Variation in  $A_v$  will be contributed by  $A_{vo}$ ,  $R_s$ , and  $R_L$ . Assume equal contribution by each. Hence the value of  $R_o$  that will keep the variation in gain within 0.5% for variation in  $R_L$  from 5 k $\Omega$  to 20 k $\Omega$  can be found from

$$\begin{aligned} \frac{5 \text{ k}}{5 \text{ k} + R_o} &= \frac{20 \text{ k}}{20 \text{ k} + R_o} \times 0.995 \\ R_o &= \frac{20 \text{ k} (1 - 0.995)}{4 \times 0.995 - 1} \geq 33.5 \Omega \end{aligned}$$

### 1.21

(a) By Kirchoff's current law at node A

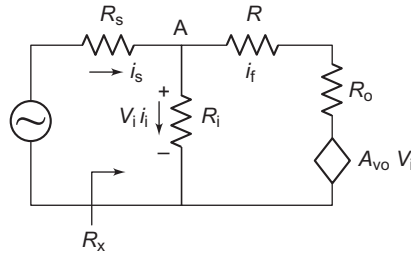

$$i_s = i_i + i_f = \frac{v_i}{R_i} + \frac{v_i - A_{vo} v_i}{R + R_o}$$

$$= v_i \left[ \frac{1}{R_i} + \frac{1 - A_{vo}}{R + R_o} \right]$$

$$R_x = \frac{v_i}{i_s} = \frac{1}{1/R_i + (1 - A_{vo})/(R + R_o)}$$

(b) For  $R_i = 50 \text{ k}$ ,  $R_o = 75 \Omega$ ,  $A_{vo} = 2$ ,  $R = 10 \text{ k}$

$$R_x = \frac{1}{1/50 \text{ k} + (1-2)/(10 \text{ k} + 75)}$$

$$= -12.62 \text{ k}\Omega$$

$$i_s = \frac{V_s}{R_s + R_x} = \frac{20 \text{ mV}}{1.5 \text{ k}\Omega - 12.62 \text{ k}\Omega} = -1.8 \mu\text{A}$$

(c) For  $i_s = 2.5 \mu\text{A}$ ,  $R_s + R_x = \frac{v_s}{i_s}$

$$= \frac{20 \text{ mV}}{-2.5 \mu\text{A}} = -8 \text{ k}\Omega$$

$$\therefore R_x = -8 \text{ k} - 1.5 \text{ k} = -9.5 \text{ k}\Omega$$

## 1.22

$$A_{is} = 200, R_i = 150 \Omega, R_o = 2.5 \text{ k}\Omega$$

$$R_L = 100 \Omega, i_s = 4 \text{ mA}, R_s = 47 \text{ k}\Omega$$

(a) From Eq. (1.30)

$$A_i = \frac{A_{is}}{(1 + R_i/R_s)(1 + R_L/R_o)} = \frac{200}{(1 + 150/47 \text{ k})(1 + 100/2500)}$$

$$= 191.7$$

$$A_v = A_i \frac{R_L}{R_s} = 191.7 \times \frac{100}{47 \text{ k}} = 0.4078$$

$$A_p = A_v A_i = 191.7 \times 0.407 = 78.17$$

(b) Problem 1.22a Amplifier

```

VS      1  0      AC  1MV
RS      1  2      47K
RI      3  0      150
F1      0  4      VX  200
VX      2  3      0V
VY      4  5      DC  0V
R0      4  0      2.5K
RL      4  0      100
. TF    V(s)    VS
. END

```

Problem 1.22b Amplifier

```

IS      0  1      AC  1MA
RS      1  0      47K
RI      2  0      150
F1      0  3      VX  200
VX      1  2      DC  0V
VY      3  5      DC  0V
R0      3  0      2.5K
RL      5  0      100
. TF    I (VY)    IS
. END
    
```

1.23

From Eqs. (1.28) and (1.29)

$$\begin{aligned}
 i_o &= \frac{A_{is} R_o}{R_o + R_L} \cdot \frac{R_s}{R_s + R_i} \cdot i_s \\
 &= \frac{10 \times 22 \times 10^3}{22 \times 10^3 + 150} \times \frac{100 \times 10^3}{10^5 + 50} \times 50 \times 10^{-3} \\
 &= 4.96 \text{ A}
 \end{aligned}$$

1.24

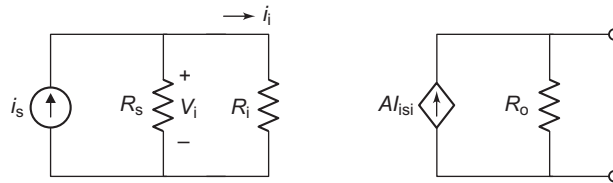

(a) Output resistance =  $\frac{\text{open-circuit voltage}}{\text{short-circuit current}}$

$$= \frac{12}{100 \times 10^{-3}} = 120 \Omega$$

$$A_{is} i_i = \text{short circuit current} = 100 \times 10^{-3} \text{ A}$$

$$i_i = i_s \frac{R_s}{R_i + R_s} = \frac{5 \times 10^{-6} \times 100 \text{ k}}{50 + 100 \text{ k}} \approx 5 \times 10^{-6} \text{ A}$$

$$A_{is} = \frac{100 \times 10^{-3}}{5 \times 10^{-6}} = 20 \times 10^3$$

$$A_v = \frac{v_o}{v_s} = A_{is} i_L \frac{R_o}{R_o + R_L} \cdot \frac{R_L}{i_s R_s}$$

$$= 100 \times 10^{-3} \times \frac{120}{120 + 2700} \times \frac{2700}{5 \times 10^{-6} \times 10^5}$$

$$= 22.98$$

$$(b) A_i = \frac{20 \times 10^3}{(1 + 50/100 \text{ k})(1 + 2.7 \text{ k}/120)} = 850.6$$

$$(c) A_p = A_v A_i = 22.98 \times 850.6$$

$$= 19,547$$

### 1.25

Following Example 1.4 we have

$$0.99 \frac{R_o}{R_o + 20} = \frac{R_o}{R_o + 500}$$

$$R_o (1 - 0.99) = 500 \times 0.99 - 20$$

$$R_o = 47.5 \text{ k}\Omega$$

For  $R_i$

$$0.99 \times \frac{100 \text{ k}}{100 \text{ k} \times R_i} = \frac{10 \text{ k}}{10 \text{ k} + R_i}$$

$$R_i = 111.23 \Omega$$

$$A_{is} = \frac{20 \times 10^{-3}}{100 \times 10^{-6}} = 200 \text{ A/A}$$

### 1.26

Assume  $A_i$  varies equally due to contribution from  $A_{is}$ ,  $R_s$ , and  $R_o$ .

$$\frac{R_o}{R_o + R_L} = 0.995, \quad \frac{R_o}{R_o + 100} = 0.995$$

$$R_o = \frac{100 \times 0.995}{1 - 0.995} \geq 19.9 \text{ k}\Omega$$

Similarly

$$\frac{R_s}{R_s + R_i} = 0.995, \quad \frac{100 \text{ k}}{100 \text{ k} + R_i} = 0.995$$

$$R_i \leq 503 \Omega$$

$$A_i = \frac{A_{is}}{(1 + R_i/R_s)(R_L/R_o)}$$

$$50 = \frac{A_{is}}{(1 + 503/100 \text{ k})(1 + 100/19.9 \text{ k})} \approx A_{is}$$

$$\therefore A_{is} \approx 50$$

1.27

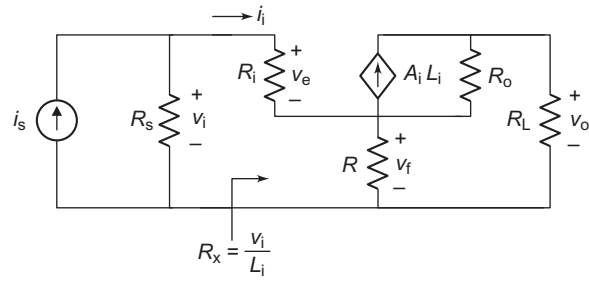

- (a)  $R$  allows a voltage that is proportional to load current  $i_o$  to be fed back to the input side.  
Converting current source to voltage source

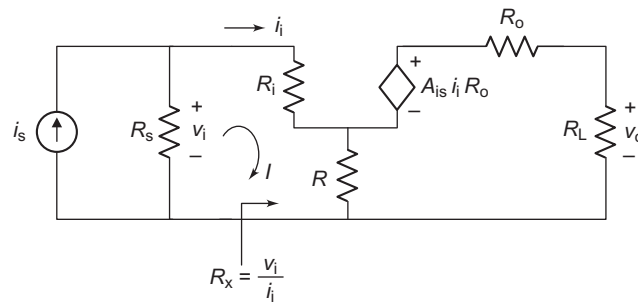

Applying KVL to loop II

$$\begin{aligned}
 A_{is} R_o i_i &= R_o i_o = R(i_i - i_o) + R_L i_o \\
 &= (R_o + R_L + R) i_o - R i_i \\
 i_o &= \frac{A_{is} R_o + R}{R_o + R_L + R} i_i \tag{1}
 \end{aligned}$$

Applying KVL to loop I

$$\begin{aligned}
 v_i &= R_i i_i + R(i_i - i_o) \\
 &= (R_i + R) i_i - R i_o \tag{2}
 \end{aligned}$$

Substituting  $i_o$  from Eq. (1) into Eq. (2) and simplifying

$$\begin{aligned}
 v_i &= (R_i + R) i_i - R \cdot \frac{A_{is} R_o + R}{R_o + R_L + R} i_i \\
 \frac{v_i}{i_i} &= R_i + R - R \frac{A_{is} R_o + R}{R_o + R_L + R} \\
 R_x = \frac{v_i}{i_i} &= R_i + R - R \frac{(A_{is} + R/R_o)}{1 + (R_L + R)/R_o}
 \end{aligned}$$

(b) Assume ideal current amplifier with  $R_i = 0$  and  $R_o = \infty$ , we have the reduced figure as

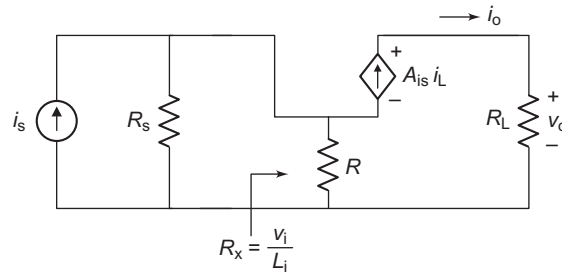

$$R_x = R - RA_{is} = R(1 - A_{is})$$

For  $A_{is} > 1$ ,  $R_x$  is negative, and if  $A_{is} = 2$

$$R_x = -R$$

For  $R_x = -10 \text{ k}\Omega$  we need  $R = 10 \text{ k}\Omega$ .

Thus an ideal current amplifier with  $A_{is} = 2$  and  $R = 10 \text{ k}\Omega$  will simulate a negative resistance.

### 1.28

(a) Using the result of Problem 1.27 for  $A_{is} = 2$  and substituting  $R$  by impedances  $Z(s)$

$$\begin{aligned} Z_x &= \frac{V_i(s)}{I_i(s)} = -Z(s) = -\left[ R + \frac{-R(R + 1/sC)}{-R + R + 1/sC} \right] \\ &= -[R - sCR^2 - R] = sCR^2 \end{aligned}$$

$Z_x = sL_e$  where the effective inductance  $L_e$  is given by  $CR^2$ . Thus, the circuit simulates an inductance.

(b) To simulate  $L_e = 10 \text{ mH}$ , let  $C = 0.01 \text{ }\mu\text{F}$ ,

$$10 \times 100^{-3} = 0.01 \times 10^{-6} \times R^2$$

$$R^2 = 10^6, R = 1 \text{ k}\Omega$$

(c) Problem 1.28 Inductance Simulation

```

IS  0  4  AC  1MA
V1  4  1  DC  0V
F1  1  0  V1  2
R1  1  2  1K
R2  2  3  1K
C1  3  0  0.01UF
V2  2  5  DC  0V
R3  5  0  1K
F2  5  0  V2  2
. AC LIN 10 1K 10K
. PRINT AC VM(1) VP(1)
. END

```

1.29

(a)

$$v_o = -G_{m1} v_i(s) \cdot \frac{1}{sC}$$

$$i_i(s) = -G_{m2} v_o(s) = G_{m1} G_{m2} \frac{v_i(s)}{sC}$$

$$Z_i = \frac{v_i(s)}{i_i(s)} = \frac{sC}{G_{m1}G_{m2}}$$

$$Z_i(j\omega) = j\omega \frac{C}{G_{m1}G_{m2}}$$

(b) Problem 1.29 Amplifier

```

VS      1      0      AC      1V
RS      1      2      100
G1      0      2      3 0      3M
G2      3      0      2 0      3M
C1      3      0      0.1UF
R1      3      0      100M
. TRAN15US1.5 MS
. PROBE
. END

```

1.30

Assuming that the discharging time constant  $\tau = CR_i$  is related to the input frequency by  $\tau = 10/f$ ,

$$CR_i = \frac{10}{60 \times 10^3}$$

(a) Let  $C = 0.1 \mu\text{F}$ , then  $R_i = \frac{10}{0.1 \times 10^{-6} \times 60 \times 10^3}$   
 $= 1.67 \text{ k}\Omega$

(b) Variation in  $G_m$ , according to Eq. (1.36), will be contributed by  $G_{ms}$  and  $R_L$ . Assume equal contributions,  $R_s = 0$ . The gain parameter

$$G_{ms} = \frac{i_o}{v_s} = \frac{20 \text{ cm}}{170 \text{ V}} \times \frac{5 \text{ mA}}{1 \text{ cm}}$$

$$= 0.588 \text{ mA/V} \pm 1\%$$

The value of  $R_o$  that will keep gain variation within 1% for variation in  $R_L$  from  $20 \Omega$  to  $500 \Omega$  can be found from

$$0.99 \frac{R_o}{R_o + 20} = \frac{R_o}{R_o + 500}$$

$$R_o \geq 47.5 \text{ k}\Omega$$

1.31

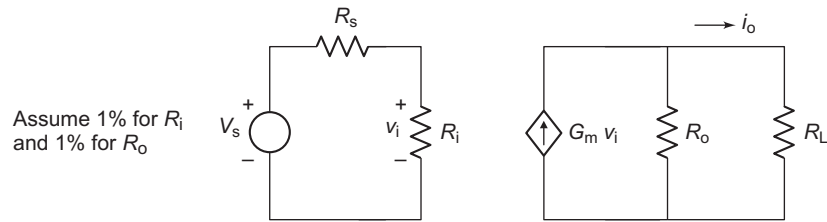

$$\frac{R_i}{R_i + R_s} \geq .99, \quad R_i (1 - 0.99) \geq 0.99 R_s$$

For  $R_s = 1 \text{ k}\Omega$ ,

$$R_i \geq \frac{0.99 \times 1 \text{ k}}{0.01} = 99 \text{ k}\Omega$$

Similarly

$$\frac{R_o}{R_o + R_L} \geq 0.99, \quad R_o \geq \frac{0.99 \times 200}{0.01}$$

$$R_o \geq 19.8 \text{ k}\Omega$$

1.32

For  $R_m = 20 \Omega$  to  $100 \Omega$

$$\frac{0.99}{R_o + 20} = \frac{1}{R_o + 100}$$

$$R_o = 7.9 \text{ k}\Omega$$

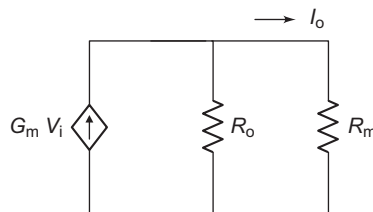

For  $R_s$  varying from  $2 \text{ k}\Omega$  to  $5 \text{ k}\Omega$

$$\frac{0.99}{R_i + 2\text{k}} = \frac{1}{R_i + 5\text{k}}, \quad R_i (1 - 0.99) = 5 \text{ k} \times 0.99 - 2 \text{ k}$$

$$R_i = 295 \text{ k}\Omega$$

For  $v_s = 10 \text{ V}$ ,  $I_o = 100 \text{ mA}$

$$G_m = \frac{I_o}{v_s} = \frac{100 \text{ mA}}{10 \text{ V}} = 10 \text{ mA/V}$$

Transconductance amplifier

**1.33**

Using Eq. (1.41)

$$Z_m = \frac{Z_{mo}}{(1 + R_o/R_L)(1 + R_i/R_s)} = \frac{0.5 \text{ k}}{(1 + 4.7 \text{ k}/4.7 \text{ k})(1 + 1.5 \text{ k}/10 \text{ k})}$$

$$= 217.39 \text{ V/A}$$

From Eq. (1.42)

$$A_v = \frac{Z_{mo} R_L}{(R_s + R_i)(R_L + R_o)} = \frac{0.5 \times 10^3 \times 4.7 \times 10^3}{(10 \times 10^3 + 1.5 \times 10^3)(4.7 \times 10^3 + 4.7 \times 10^3)}$$

$$= 21.739 \times 10^{-3}$$

$$i_i = \frac{R_s}{R_s + R_i} \cdot i_s = \frac{10^4 \times 50 \times 10^{-3}}{10^4 + 1.5 \times 10^3} = \frac{500}{11.5 \times 10^3} \text{ mA}$$

From Eq. (1.39)

$$v_o = Z_{mo} \frac{i_i R_L}{R_L + R_o} = 0.5 \text{ k} \times \frac{500}{11.5 \times 10^3} \times \frac{4.7 \times 10^3}{(4.7 \times 10^3 + 4.7 \times 10^3)}$$

$$= 10.87 \text{ V}$$

$$i_o = \frac{10.87}{4.7 \times 10^3} = 2.31 \times 10^{-3} \text{ A}$$

$$A_i = \frac{i_o}{i_s} = \frac{2.3 \times 10^{-3}}{50 \times 10^{-3}} = 0.046$$

**1.34**

Since the output variation should be kept within  $\pm 2\%$ , variation of effective transimpedance  $Z_m$  should be kept to  $\pm 2\%$ . According to Eq. (1.41) the variation in  $Z_m$  will be contributed by  $Z_{mo}$  and  $R_o$ . Assume equal contribution to the variation.

Let  $R_i = 10 \Omega$ . Then

$$Z_{mo} = \frac{10 \text{ V}}{2 \text{ cm}} \times \frac{20 \text{ cm}}{100 \text{ mA}} = 1000 \text{ V/A} \pm 1\%$$

The value of  $R_o$  that will keep gain variations within 1% for variation of  $R_L$  from 2 k $\Omega$  to 10 k $\Omega$  is

$$\frac{0.99 \times 10 \text{ k}}{10 \text{ k} + R_o} = \frac{2 \text{ k}}{2 \text{ k} + R_o}$$

$$R_o \cong 25 \Omega$$

Design specifications are  $Z_{mo} = 1000 \text{ V/A}$ ,  $R_o \leq 25 \Omega$ , and  $R_i \leq 10 \Omega$ .

**1.35**

Let  $R_i = 10 \text{ k} \ll R_s$

$$i_i = \frac{R_s}{R_s + R_i} \cdot i_s = \frac{10^5 \times 0.5}{10^5 + 10^4} = 454.5 \text{ mA}$$

$$\frac{R_s}{R_i + R_s} = 0.99, \quad R_i \times 0.99 + 0.99R_s = R_s$$

$$R_i = \frac{R_s (1 - 0.99)}{0.99} = \frac{100 \text{ k} \times 0.01}{0.99}$$

$$= 101 \text{ k}\Omega$$

$$\frac{R_m}{R_m + R_o} = 0.99, \quad R_o = \frac{R_m (1 - 0.99)}{0.99}$$

$$= \frac{20 \text{ k} \times 0.01}{0.99} = 202$$

$$Z_{mo} = \frac{V_o}{i_i} = \frac{5}{454 \cdot 5 \times 10^{-3}} = 11 \text{ V/A} \pm 1\%$$

1.36

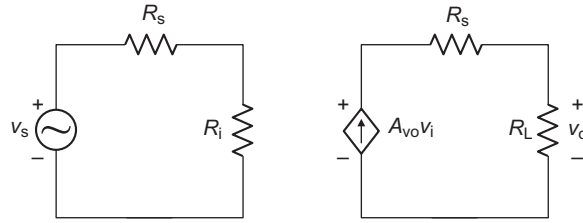

Voltage amplifier

For ideal voltage amplifier

$$R_o = 0 \text{ and } R_i = \infty$$

$$v_o = A_{vo} v_i \quad (1)$$

For ideal current amplifier

$$R_o = \infty, R_i = 0$$

$$i_o = A_{is} i_s \quad (2)$$

$$\therefore v_o = A_{vo} v_i = i_o R_o = A_{is} i_s R_o = A_{is} i_i R_o$$

Using

$$v_i = i_i R_i$$

$$A_{vo} i_i R_i = A_{is} i_i R_o$$

$$A_{vo} = A_{is} \frac{R_o}{R_i} \quad (3)$$

For ideal transconductance amplifier

$$i_o = G_{ms} v_s \text{ for } R_o = \infty, R_i = \infty$$

$$v_o = A_{vo} v_i = i_o R_o = G_{ms} v_i R_o$$

$$\therefore A_{vo} = G_{ms} R_o \quad (4)$$

For ideal transimpedance amplifier

$$R_i = 0, R_o = 0$$

$$v_o = Z_{mo} i_s = Z_{mo} \cdot i_i$$

$$v_o = A_{vo} v_i = Z_{mo} \frac{v_o}{R_i}$$

$$\therefore A_{vo} = \frac{Z_{mo}}{R_i} \quad (5)$$

Using

$$A_{vo} = A_{is} \frac{R_o}{R_i}$$

$$A_{is} = A_{vo} \frac{R_i}{R_o} = 250 \times \frac{50 \times 10^3}{1 \times 10^3} = 12,500 \text{ A/A}$$

$$A_{vo} = G_{ms} R_o, \quad G_{ms} = \frac{A_{vo}}{R_o} = \frac{250}{1000}$$

$$= 0.25 \text{ A/V}$$

$$Z_{mo} = A_{vo} \cdot R_i = 250 \times 50 \times 10^3$$

$$= 12.5 \text{ M}\Omega$$

Equivalent amplifiers are:

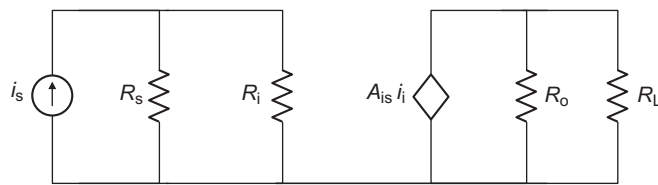

Equivalent current amplifier

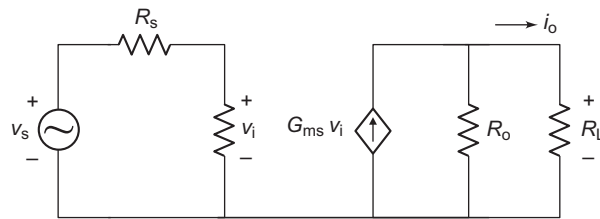

Equivalent transconductance amplifier

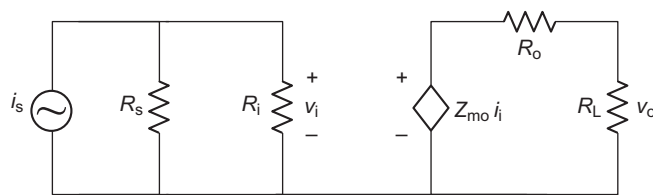

Equivalent transimpedance amplifier

1.37

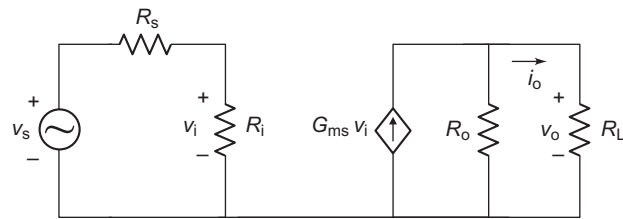

Transconductance amplifier

$$G_{ms} = 20 \text{ mA/V}$$

$$A_{vo} = G_{ms} R_o = 20 \times 10^{-3} \times 2 \times 10^3 = 40 \text{ V/V}$$

$$A_{vo} = A_{is} \frac{R_o}{R_i}$$

$$\begin{aligned} \text{or } A_{is} &= A_{vo} \cdot \frac{R_i}{R_o} = \frac{40 \times 100 \times 10^3}{2 \times 10^3} \\ &= 40 \times 50 = 2000 \text{ A/A} \end{aligned}$$

$$\begin{aligned} Z_{mo} &= A_{vo} \cdot R_i = 40 \times 100 \times 10^3 \\ &= 4 \text{ M}\Omega \end{aligned}$$

Equivalent circuits

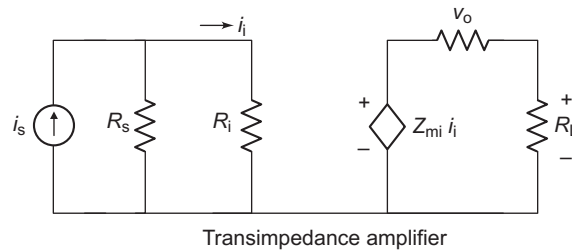
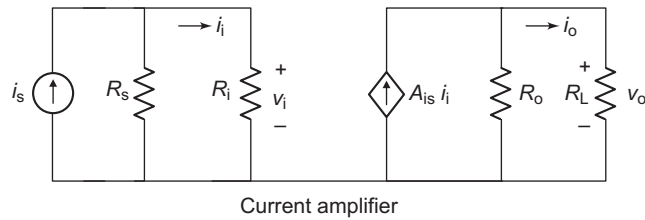
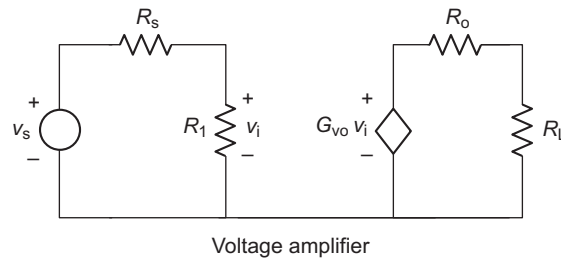

### 1.38

(a) From Eq. (1.21)

$$\begin{aligned} A_{v1} &= A_{v2} = A_{vo} \frac{R_{i2}}{R_{i2} + R_{o1}} = \frac{50 \times 2.5 \times 10^3}{2.5 \times 10^3 + 100} \\ &= 48 \end{aligned}$$

From Eq. (1.45), the overall open-circuit voltage gain

$$\begin{aligned} A_{vo} &= \frac{V_o}{V_i} = A_{v1} \cdot A_{v2} \cdot A_{v3} \\ &= 48 \times 48 \times 50 = 115,200 \text{ or } 101.22 \text{ dB} \end{aligned}$$

Total effective voltage gain using Eq. (1.23)

$$A_v = \frac{V_o}{V_s} = \frac{A_{vo} R_i R_L}{(R_i / R_s)(R_L / R_o)}$$

$$= \frac{115200 \times 2.5 \times 10^3 \times 2.5 \times 10^3}{(2.5 \times 10^3 + 200 \times 10^3)(2.5 \times 10^3 + 100)}$$

$$= 1367.5 \text{ or } 62 \text{ dB}$$

Overall current gain

$$A_i = \frac{i_o}{i_i} = \frac{A_{vo} \cdot R_{i1}}{R_L + R_{o3}} = \frac{115200 \times 2500}{2500 + 100}$$

$$= 110,769 \text{ or } 100.9 \text{ dB}$$

$$A_p = \frac{P_L}{P_i} = A_v \cdot A_i = 1367.5 \times 110769$$

$$= 1.5 \times 10^8 \text{ or } 81.7 \text{ dB}$$

**(b) Problem 1.38 Cascaded Amplifier**

```

VS      1  0  AC 100 MV
RS      1  2  200K
RI1     2  0  2.5K
E1      3  0  4    50
R01     3  4  100
RI2     4  0  2.5K
E2      5  0  40   50
R02     5  6  100
RI3     6  0  2.5K
E3      7  0  60   50
R03     7  8  100
RL      8  0  2.5K
. TF    V(8) VS
. END

```

**1.39**

**(a)** Using Eq. (1.21),  $A_v$  of stage 1 and 2 is given by

$$A_{v1} = A_{v2} = \frac{A_{vo1} R_{i2}}{R_{i2} + R_{o1}} = \frac{80 \times 2500}{2500 + 100}$$

$$= 76.9$$

From Eq. (1.45), the overall open-circuit voltage gain

$$A_{vo} = A_{v1} \cdot A_{v2} \cdot A_{vo3} = 76.9^2 \times 80 = 473,088 \text{ or } 113.5 \text{ dB}$$

From Eq. (1.23)

$$A_v = \frac{A_{vo} \cdot R_i R_L}{(R_i + R_s)(R_L + R_o)} = \frac{473,088 \times 2500 \times 1500}{(2500 + 200 \times 10^3)(1.5 \times 10^3 + 300)}$$

$$= 4867 \text{ or } 73.7 \text{ dB}$$

$$A_i = \frac{A_{vo} R_{Li}}{R_L + R_{o3}} = \frac{473,088 \times 2500}{1.5 \times 10^3 + 300} = 657,066.7 \text{ or } 116.6 \text{ dB}$$

$$A_p = A_v A_i = 4867 \times 657,066.7 = 3.19 \times 10^9 \text{ or } 95 \text{ dB}$$

**(b) Problem 1.39 Cascaded Amplifier**

```

VS      1  0  AC100MV
RS      1  2  200K
RI1     2  0  2.5K
E1      3  0  2  0  80
R01     3  4  100
RI2     4  0  2.5K
E2      5  0  4  0  80
R02     5  6  100
RI3     6  0  2.5K
E3      7  0  6080
R03     7  8  300
RL      8  0  1.5K
. TF    V(8) VS
. END

```

**1.40**

**(a)**

$$i_o = \frac{A_{is3} i_{i3} R_{o3}}{R_{o3} + R_L} = \frac{A_{is3} R_{o3}}{R_{o3} + R_L} \frac{A_{is2} i_{i2} R_{o2}}{R_{o2} + R_{i3}}$$

$$= \frac{A_{is3} A_{is2} R_{o3} R_{o2}}{(R_{o3} + R_L)(R_{o2} + R_{i3})} \cdot \frac{A_{is1} i_{i1} R_{o1}}{(R_{o1} + R_{i2})}$$

$$= \frac{A_{is3} A_{is2} A_{is1} R_{o3} R_{o2} R_{o1}}{(R_{o3} + R_L)(R_{o2} + R_{i3})(R_{o1} + R_{i2})} \cdot \frac{R_s i_i}{R_s + R_{i1}}$$

$$A_i = \frac{i_o}{L_s} = \frac{A_{is3} A_{is2} A_{is1} R_{o3} R_{o2} R_{o1}}{(R_{o3} + R_L)(R_{o2} + R_{i3})(R_{o1} + R_{i2})} \cdot \frac{R_s}{(R_s + R_{i1})}$$

$$= \frac{100^3 (4.7 \times 10^3)^3 \times 20 \times 10^3}{(4700 + 100)(4700 + 100)(4700 + 100)(20 \times 10^3 + 100)}$$

$$= 934,122 \text{ or } 119.4 \text{ dB}$$

$$A_v = \frac{V_o}{V_s} = \frac{i_o R_i}{i_{i1} R_{i1}} \text{ on substitution for } A_v \text{ from above}$$

$$A_v = \frac{A_{is3} A_{is2} A_{is1} R_{o3} R_{o2} R_{o1} R_L}{(R_{o3} + R_L)(R_{o2} + R_{i3})(R_{o1} + R_{i2}) R_{i1}}$$

$$= \frac{10^6 \times 10^9 \times 4.7^3 \times 10^2}{48^3 \times 10^6 \times 10^2}$$

$$= 42,498.5 \text{ or } 92.56 \text{ dB}$$

$$A_p = A_v A_i = 42,498.5 \times 934,122 = 3.97 \times 10^{10} \text{ or } 105 \text{ dB}$$

**(b) Problem 1.40 Cascaded Current Amplifier**

```
IS      1  0  AC 100MA
RS      1  0  20K
V1      1  2  DC 0V
RI1     2  0  100
F1      0  3  V1 100
R01     3  0  4.7K
V2      3  4  DC 0V
RI2     4  0  100
R02     5  0  4.7K
V3      5  6  DC 0V
RI3     6  0  100
F3      7  0  V3 100
R03     7  0  4.7K
VX      7  8  DC 0V
RL      8  0  100
. TF I (VX) IS
. END
```

**1.41**

**(a)**

$$i_o = \frac{G_{ms} V_{i2} R_{o2}}{R_{o2} + R_L} = - \frac{G_{ms} R_{o2}}{R_{o2} + R_L} \cdot \frac{Z_{mo} i_i R_{i2}}{R_{o1} + R_{i2}}$$
$$A_i = \frac{i_o}{i_i} = \frac{-20 \times 10^{-3} \times 10^5}{10^5 + 10^3} \times \frac{10^4 + 10^6}{200 + 10^6} = -198$$
$$A_v = \frac{V_o}{V_i} = \frac{+i_o R_L}{i_i R_{i1}} = - \frac{198 \times 10^3}{50 \times 10^3} = -3.96$$
$$A_p = A_i A_v = -198 \times -3.96 = 784$$

**(b) Problem 1.41 Transconductance Amplifier**

```
VS      1  0  AC 10MV
RS      1  2  5K
VX      2  3  DC 0V
RI1     3  0  50K
H1      4  0  VX 10K
R01     4  5  200
RI2     5  0  1MEG
G1      6  0  5  0  20M
R02     6  0  100K
RL      6  0  1K
. TF V (6) VS
. END
```

1.42

From Eq. (1.54d)

$$f_L = \frac{1}{2\pi R_1 C_1} = \frac{1}{2\pi \times 147 K\Omega \times 0.1 nF} = 10.8 KHz$$

1.43

From Eq. (1.54d)

$$f_L = \frac{1}{2\pi R_1 C_1}$$

$$R_1 = \frac{1}{2\pi f_L C_1} = \frac{1}{2\pi \times 4 \times 10^3 \times 0.01 \times 10^{-6}} = 3.979 K\Omega$$

1.44

From Eq. (1.59d)

$$f_H = \frac{1}{2\pi \times 147 \times 10^3 \times 0.1 \times 10^{-9}} = 10.8 KHz$$

1.45

From Eq. (1.59d)

$$f_H = \frac{1}{2\pi R_2 C_2}$$

$$R_2 = \frac{1}{2\pi f_H C_2} = \frac{1}{2\pi \times 25 \times 10^3 \times 0.01 \times 10^{-6}} = 636.6 K\Omega$$

1.46

$$A_v(j\omega) = \frac{200}{1 + j\omega/100} = \frac{2 \times 10^4}{100 + j\omega}$$

$$|A_v(j\omega)| = \frac{210^4}{\sqrt{\omega^2 + 10^4}}$$

$$\begin{aligned} \text{(a)} \quad 100 &= \frac{2 \times 10^4}{\sqrt{\omega_H^2 + 10^4}}, \quad \omega_H = \sqrt{3 \times 10^4} \\ &= 173.2 \text{ rad/s} \end{aligned}$$

$$f_H = \frac{173.2}{2\pi} = 27.56 \text{ Hz} = \text{BW}$$

$$\text{(b)} \quad 50 = \frac{2 \times 10^4}{\sqrt{\omega_H^2 + 10^4}}, \quad \omega_H^2 \times 10^4 = 16 \times 10^4$$

$$\omega_H = 387.29 \text{ rad/s}$$

$$f_H = \frac{387.29}{2\pi} = 61.64 \text{ Hz} = \text{BW}$$

1.47

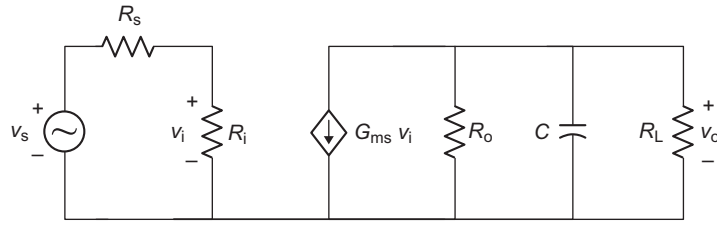

$$\begin{aligned} \text{(a)} \quad v_o &= -G_{ms} v_i \left( R_o \parallel \frac{1}{sC} \parallel R_L \right) \\ &= -20 \times 10^{-3} v_i \left( 980 \parallel \frac{1}{sC} \right) \end{aligned} \quad \text{(i)}$$

$$v_i = \frac{5 \times 10^5 v_s}{505 \times 10^3} = 0.99 v_s \text{ then}$$

$$v_o = -20 \times 10^{-3} \times (0.99 v_s) \times \left( 980 \parallel \frac{1}{sC} \right)$$

$$A_v = \frac{-20 \times 10^3 \times 0.99 \times 980}{1 + 980 j\omega C} = \frac{-19.404}{1 + j\omega 980 \times 0.1 \times 10^{-6}}$$

$$A_{v(\text{mid})} = 19.404$$

$$\omega_H = \frac{10^6}{980 \times 0.1} = 10,204$$

$$f_H = \frac{10204}{2\pi} = 1624 \text{ Hz}$$

$$f_{bw} = A_{v(\text{mid})} \times f_H = 19.404 \times 1624 = 31,512$$

$$\text{(b)} \quad R_L = 10 \text{ k}\Omega, \quad R_o \parallel R_L = 10 \text{ k} \parallel 50 \text{ k} = 8333 \Omega$$

$$A_v = \frac{-20 \times 10^{-3} \times 0.99 \times 8333}{1 + j\omega 8333 \times 0.1 \times 10^{-6}} = -\frac{165}{1 + j\omega \times 833.3 \times 10^{-6}}$$

$$\omega_H = \frac{10^6}{833.3}, \quad f_H = 190 \text{ Hz}$$

$$f_{bw} = 165 \times 190 = 31,350$$

1.48

$$\begin{aligned} v_o &= -g_m v_i \left( R_L \parallel \frac{1}{sC_L} \right) = \frac{-v_i g_m R_L}{1 + sR_L C_2} \\ &= \frac{-v_i g_m}{C_2 (s + 1/R_L C_2)} \end{aligned} \quad \text{(1)}$$

$$v_i = \frac{v_s R_i}{R_s + R_i + 1/sC_i} = \frac{v_s R_i s}{(R_s + R_i)[s + 1/C_i (R_s + R_i)]} \quad \text{(2)}$$

From (1) and (2)

$$v_o = -\frac{v_s g_m R_i s}{C_2(R_s + R_i)(s + 1/R_L C_2)[s + 1/C_1(R_s + R_i)]}$$

$$\omega_H = \frac{1}{R_L C_2} = \frac{1}{10 \times 10^3 \times 10 \times 10^{-12}} = 10^7 \text{ rad/s}$$

$$\text{or } f_H = \frac{10^7}{2\pi} = 1.59 \text{ MHz}$$

$$\omega_L = \frac{1}{C_1(R_s + R_i)} = \frac{1}{20 \times 10^{-6} \times 1500} = \frac{100}{3} \text{ rad/s}$$

$$f_L = \frac{100}{3 \times 2\pi} = 5.3 \text{ Hz}$$

For  $A_{v(\text{mid})}$

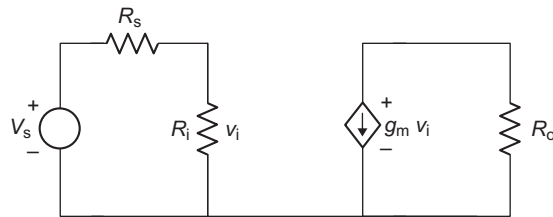

$$v_o = -g_m v_i R_o = -\frac{g_m R_i \cdot R_o}{R_s + R_i} v_s$$

$$= \frac{-15 \times 10^{-3} \times 10^4 \times 10^3}{1500} = -100$$

#### Problem 1.48

```

VS      1      0      AC      10MV
RS      1      2      500
C1      2      3      20UF
RI      3      0      1K
G1      4      0      3      0      15M
RL      4      0      10K
C2      4      0      10PF
.AC    DEC    100    1      10 MEG
.PRINT    AC    VM(4)
.PROBE
.END

```

1.49

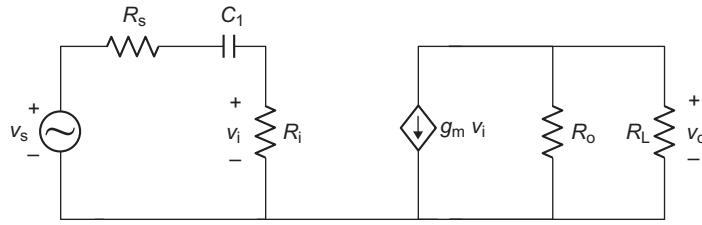

Low-frequency equivalent circuit

$$v_o = -g_m v_i (R_o \parallel R_L) = -15 \times 10^{-3} \times 5 \times 10^3 v_i = -7.5 v_i \quad (i)$$

$$v_i = \frac{R_i v_s}{R_s + R_i + 1/sC_1} = \frac{R_i s C_1 v_s}{1 + (R_s + R_i)sC_1}$$

$$= \frac{v_s s 25 \times 10^3 \times 10 \times 10^{-6}}{1 + s(25 \times 10^3 + 1 \times 10^3)10 \times 10^{-6}} = \frac{v_s s 0.25}{1 + 26 \times 10^{-2} s} \quad (ii)$$

From (i) and (ii)

$$v_o = \frac{75 \times 0.255}{1 + 26 \times 10^{-2} s} \quad (iii)$$

$$f_L = \frac{1}{26 \times 10^{-2} \times 2\pi} = 0.612 \text{ Hz}$$

For high-frequency equivalent circuit

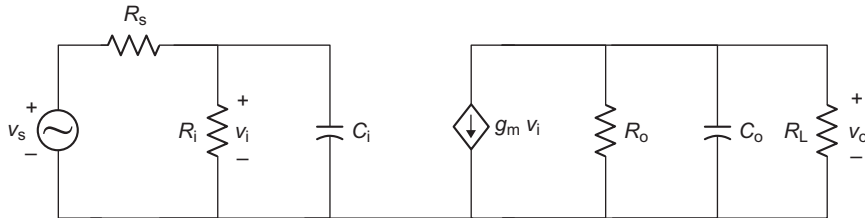

$$v_o = -g_m v_i \left( R_o \parallel R_L \parallel \frac{1}{sC_o} \right)$$

$$= -15 \times 10^3 \frac{5 \times 10^3 v_i}{1 + 5 \times 10^3 \times 10 \times 10^{-12} s}$$

$$= \frac{-75 v_i}{1 + 5 \times 10^{-8} s}$$

$$v_i = \frac{(R_i \parallel 1/sC_i) v_s}{R_s + R_i \parallel 1/sC_i}$$

$$= \frac{R_i v_s}{R_i + R_s + sR_i R_s C_i}$$

$$= \frac{25 \times 10^3 v_s}{25 \times 10^3 + 10^3 + s \times 25 \times 10^3 \times 10^3 \times 20 \times 10^{-12}}$$

$$= \frac{25 v_s}{26 + s 500 \times 10^{-9}} = \frac{25 v_s}{26 + s \times 5 \times 10^{-7}}$$

$$A_{v(s)} = \frac{v_o}{v_s} = \frac{-75}{(1 + 5 \times 10^{-8} s)} \times \frac{25}{26 + 5 \times 10^{-7} s}$$

$$= \frac{-75 \times 25}{26 (1 + 5 \times 10^{-8} s) (1 + 5 \times 10^{-7} s / 26)}$$

$$f_H = \frac{1}{2\pi \times 5 \times 10^{-8}} = 3.18 \text{ MHz}$$

$$A_{v(\text{mid})} = \frac{-75 \times 25}{26} = -72.1$$

**Problem 1.49**

```

VS      1      0      AC      10MV
RS      1      2      1K
C1      2      3      10UF
RI      3      0      25K
G1      4      0      3      0      15M
RL      4      0      10K
R0      4      0      10K
C0      4      0      10PF
. AC    DEC 100      1      10MEG
. PRINT AC VM(4)
. PROBE
. END

```

**1.50**

$$R_m = \frac{1 \text{ V}}{I_m} = \frac{1 \text{ V}}{100 \mu\text{A}} = 10 \text{ k}\Omega$$

$$\frac{10 \text{ k} \times 400}{R_1 + 10 \text{ k}} = 1 \text{ V}, R_1 = 10 \text{ k} (400 - 1) = 3990 \text{ k}\Omega$$

Take  $R_1 \approx 4 \text{ M}\Omega \pm 1\%$ .

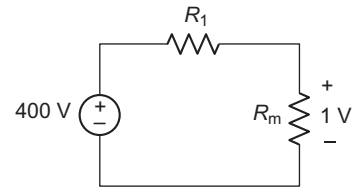

**1.51**

$$R_L = \frac{6 \text{ V}}{5 \text{ A}} = 1.2 \Omega$$

$$\frac{1.2 \times 24}{R_1 + 1.2} = 6 \text{ V}, R_1 = \frac{1.2 \times 24}{6} - 1.2 = 3.6 \Omega$$

Take  $R_1 = 3.6 \Omega \pm 5\%$ .

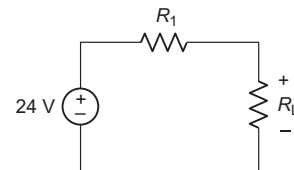

1.52

$$\frac{V^2}{R_L} = \frac{50^2}{R_L} = 60 \text{ W}$$

$$R_L = \frac{50^2}{60} = 41.667 \Omega$$

$$\frac{R_L \times 120}{R_1 + R_L} = 50 \text{ V}$$

$$\frac{41.667 \times 120}{50} = R_1 + 41.667, \quad R_1 = 58.334 \Omega$$

Take  $R \approx 62 \Omega \pm 5\%$ .

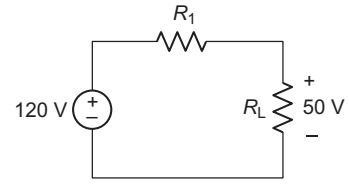

1.53

$$I_0 = 1 \text{ mA}$$

$$i(t) = \frac{V_s}{R} e^{-t/\tau}$$

$$\frac{V_s}{R} = \frac{24}{R} = 1 \text{ mA}, \quad R = 24 \text{ k}\Omega \pm 5\%$$

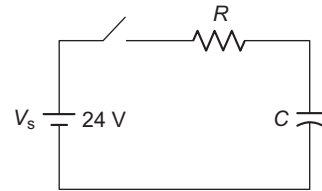

1.54

$$|A_v| = \frac{V_O}{V_I} = \frac{400}{5} = 80, \quad Q = 60^\circ$$



# Chapter 2

## 2.1

(a)  $v_d = v_o/A_o = \pm 15 \text{ V}/2 \times 10^5 = \pm 75 \mu\text{V}$

(b)  $i_i = v_d/R_i = \pm 75 \mu\text{V}/2 \times 10^6 = \pm 37.5 \times 10^{-12} \text{ A}$

## 2.2

$$v_o = (v_+ - v_-) = A_o v_s = 10^5 \times 50 \times 10^{-6} = 5 \text{ V}$$

## 2.3

$$v_o = -A_o v_d = -A_v v_s = -10^5 \times 10 \times 10^{-6} = -1 \text{ V}$$

## 2.4

$$v_o = A_o (v_+ - v_-) = 2 \times 10^5 (0 - 2 \sin 377t)$$

Output saturates at  $\pm 14 \text{ V}$ .

## 2.5

$$v_o = A_o (v_+ - v_-) = 2 \times 10^5 (75 + 25)10^{-6} = +20 \text{ V}; \text{ at saturation, } v_o = +14 \text{ V}$$

## 2.6

(a)  $v_d = v_1 - v_2 = (120 - 80) \mu\text{V} = 40 \mu\text{V}$

(b)  $v_c = \frac{v_1 + v_2}{2} = \frac{200}{2} = 100 \mu\text{V}$

(c)  $20 \log \text{CMMR} = 90$

$$\log \text{CMMR} = 90/20 \text{ or } |A_d/A_c| = 31,622$$

$$|A_c| = |A_d|/31,622 = \frac{2 \times 10^5}{31,622} = \pm 6.32$$

(d)  $v_o = A_d v_d \pm A_c v_c = 2 \times 10^5 \times 40 \times 10^{-6} \pm 6.32 \times 80 \times 10^{-6}$   
 $= 8 \pm 50.56 \times 10^{-6} \text{ V}$

## 2.7

(a)  $v_d = v_2 - v_1 = 60 \mu\text{V} - 100 \mu\text{V} = -40 \mu\text{V}$

(b)  $v_c = \frac{v_1 + v_2}{2} = \frac{60 + 100}{2} \mu\text{V} = 80 \mu\text{V}$

(c)  $20 \log \text{CMRR} = 90 \text{ dB}$

$$\log \text{CMRR} = 4.5$$

$$\left| \frac{A_d}{A_c} \right| = 3.1622 \times 10^4$$

$$A_c = \frac{A_d}{3.1622 \times 10^4} = \frac{2 \times 10^5}{3.1622 \times 10^4} = 6.3247$$