

# Table of Contents

---

Problems Solutions	2
Exercise Solutions	30

Contact me in order to access the whole complete document. Email: [solution9159@gmail.com](mailto:solution9159@gmail.com)  
WhatsApp: <https://wa.me/message/2H3BV2L5TTSUF1> Telegram: <https://t.me/solutionmanual>

**Solutions to End-of-Chapter Problems**

$$1.1 \text{ (a) } I = \frac{V}{R} = \frac{0.5 \text{ V}}{1 \text{ k}\Omega} = 0.5 \text{ mA}$$

$$\text{(b) } R = \frac{V}{I} = \frac{2 \text{ V}}{1 \text{ mA}} = 2 \text{ k}\Omega$$

$$\text{(c) } V = IR = 0.1 \text{ mA} \times 20 \text{ k}\Omega = 2 \text{ V}$$

$$\text{(d) } I = \frac{V}{R} = \frac{5 \text{ V}}{100 \Omega} = 0.05 \text{ A} = 50 \text{ mA}$$

*Note:* Volts, milliamps, and kilohms constitute a consistent set of units.

$$1.2 \text{ (a) } P = I^2 R = (20 \times 10^{-3})^2 \times 1 \times 10^3 = 0.4 \text{ W}$$

Thus,  $R$  should have a  $\frac{1}{2}$ -W rating.

$$\text{(b) } P = I^2 R = (40 \times 10^{-3})^2 \times 1 \times 10^3 = 1.6 \text{ W}$$

Thus, the resistor should have a 2-W rating.

$$\text{(c) } P = I^2 R = (1 \times 10^{-3})^2 \times 100 \times 10^3 = 0.1 \text{ W}$$

Thus, the resistor should have a  $\frac{1}{8}$ -W rating.

$$\text{(d) } P = I^2 R = (4 \times 10^{-3})^2 \times 10 \times 10^3 = 0.16 \text{ W}$$

Thus, the resistor should have a  $\frac{1}{4}$ -W rating.

$$\text{(e) } P = V^2/R = 20^2/(1 \times 10^3) = 0.4 \text{ W}$$

Thus, the resistor should have a  $\frac{1}{2}$ -W rating.

$$\text{(f) } P = V^2/R = 11^2/(1 \times 10^3) = 0.121 \text{ W}$$

Thus, a rating of  $\frac{1}{8}$  W should theoretically suffice, though  $\frac{1}{4}$  W would be prudent to allow for inevitable tolerances and measurement errors.

$$1.3 \text{ (a) } V = IR = 2 \text{ mA} \times 1 \text{ k}\Omega = 2 \text{ V}$$

$$P = I^2 R = (2 \text{ mA})^2 \times 1 \text{ k}\Omega = 4 \text{ mW}$$

$$\text{(b) } R = V/I = 1 \text{ V}/20 \text{ mA} = 50 \text{ k}\Omega$$

$$P = VI = 1 \text{ V} \times 20 \text{ mA} = 20 \text{ mW}$$

$$\text{(c) } I = P/V = 100 \text{ mW}/1 \text{ V} = 100 \text{ mA}$$

$$R = V/I = 1 \text{ V}/100 \text{ mA} = 10 \Omega$$

$$\text{(d) } V = P/I = 2 \text{ mW}/0.1 \text{ mA} = 20 \text{ V}$$

$$R = V/I = 20 \text{ V}/0.1 \text{ mA} = 200 \text{ k}\Omega$$

$$\text{(e) } P = I^2 R \Rightarrow I = \sqrt{P/R}$$

$$I = \sqrt{100 \text{ mW}/1 \text{ k}\Omega} = 10 \text{ mA}$$

$$V = IR = 10 \text{ mA} \times 1 \text{ k}\Omega = 10 \text{ V}$$

*Note:* V, mA, k $\Omega$ , and mW constitute a consistent set of units.

1.4 See figure on next page, which shows how to realize the required resistance values.

1.5 Shunting the 10 k $\Omega$  by a resistor of value of  $R$  result in the combination having a resistance  $R_{\text{eq}}$ ,

$$R_{\text{eq}} = \frac{10R}{R + 10}$$

Thus, for a 1% reduction,

$$\frac{R}{R + 10} = 0.99 \Rightarrow R = 990 \text{ k}\Omega$$

For a 5% reduction,

$$\frac{R}{R + 10} = 0.95 \Rightarrow R = 190 \text{ k}\Omega$$

For a 10% reduction,

$$\frac{R}{R + 10} = 0.90 \Rightarrow R = 90 \text{ k}\Omega$$

For a 50% reduction,

$$\frac{R}{R + 10} = 0.50 \Rightarrow R = 10 \text{ k}\Omega$$

Shunting the 10 k $\Omega$  by

(a) 1 M $\Omega$  results in

$$R_{\text{eq}} = \frac{10 \times 1000}{1000 + 10} = \frac{10}{1.01} = 9.9 \text{ k}\Omega$$

a 1% reduction;

(b) 100 k $\Omega$  results in

$$R_{\text{eq}} = \frac{10 \times 100}{100 + 10} = \frac{10}{1.1} = 9.09 \text{ k}\Omega$$

a 9.1% reduction;

(c) 10 k $\Omega$  results in

$$R_{\text{eq}} = \frac{10}{10 + 10} = 5 \text{ k}\Omega$$

a 50% reduction.

$$1.6 \quad V_O = V_{DD} \frac{R_2}{R_1 + R_2}$$

To find  $R_O$ , we short-circuit  $V_{DD}$  and look back into node X,

$$R_O = R_2 \parallel R_1 = \frac{R_1 R_2}{R_1 + R_2}$$

This figure belongs to Problem 1.4.

All resistors are 5 kΩ

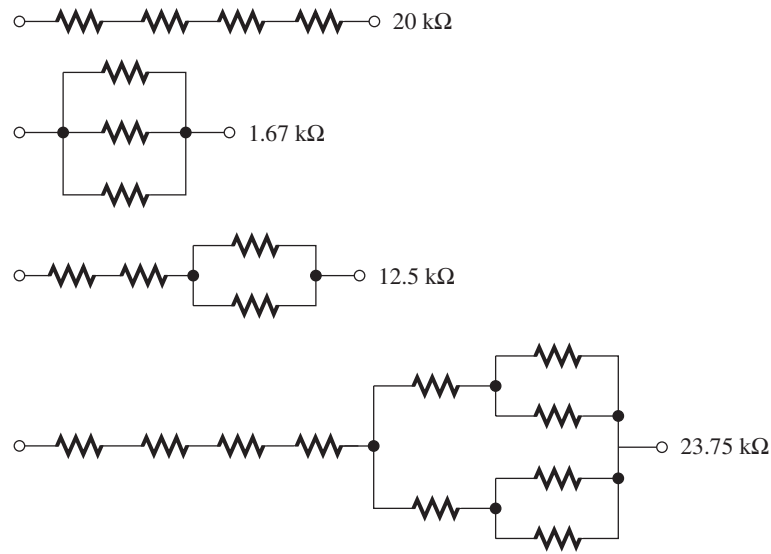

1.7 Use voltage divider to find  $V_o$

$$V_o = 1 \frac{2}{2+1} = 2 \text{ V}$$

Equivalent output resistance  $R_o$  is

$$R_o = (2 \text{ k}\Omega \parallel 1 \text{ k}\Omega) = 0.667 \text{ k}\Omega$$

The extreme values of  $V_o$  for  $\pm 5\%$  tolerance resistor are

$$V_{o\min} = 3 \frac{2(1-0.05)}{2(1-0.05) + 1(1+0.05)}$$

$$= 1.93 \text{ V}$$

$$V_{o\max} = 3 \frac{2(1+0.05)}{2(1+0.05) + 1(1-0.05)}$$

$$= 2.07 \text{ V}$$

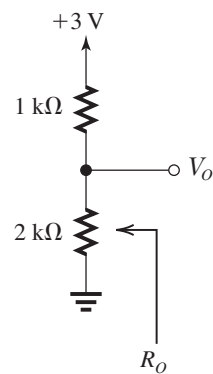

The extreme values of  $R_o$  for  $\pm 5\%$  tolerance resistors are  $667 \times 1.05 = 700 \text{ k}\Omega$  and  $667 \times 0.95 = 633 \text{ k}\Omega$ .

1.8

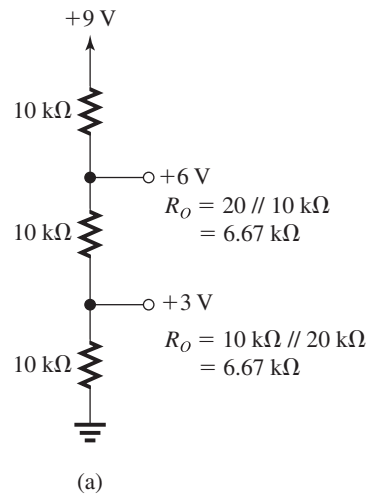

(a)

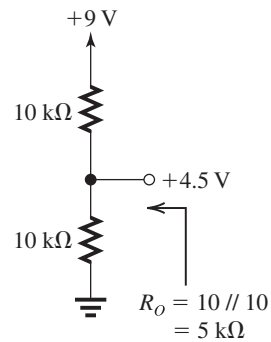

(b)

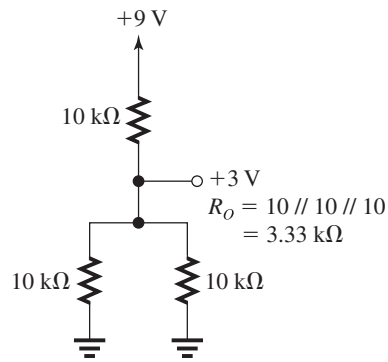

(c)

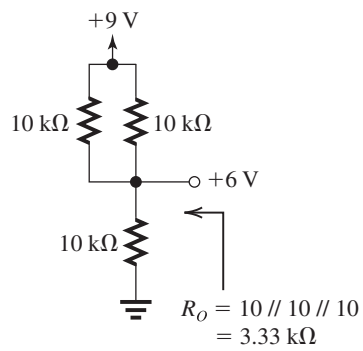

(d)

Voltage generated:  
 +3V [two ways: (a) and (c) with (c) having lower output resistance]  
 +4.5 V (b)  
 +6V [two ways: (a) and (d) with (d) having a lower output resistance]

1.9

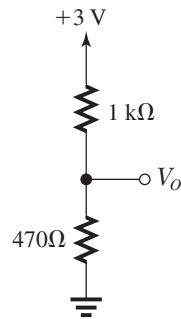

$$V_O = 3 \frac{0.47}{1 + 0.47} = 0.96 \text{ V}$$

To increase  $V_O$  to 1.00 V, we shunt the 1-k $\Omega$  resistor by a resistor  $R$  whose value is such that  $1 \parallel R = 2 \times 0.47$ .

Thus

$$\frac{1}{1} + \frac{1}{R} = \frac{1}{0.94}$$

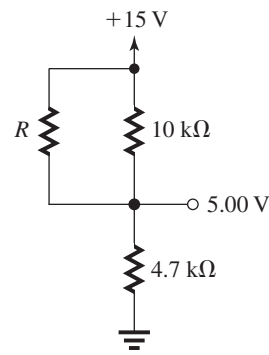

$$\Rightarrow R = 15.67 \text{ k}\Omega$$

Now,

$$R_O = 1 \text{ k}\Omega \parallel R \parallel 0.47 \text{ k}\Omega = 0.94 \parallel 4.7 = \frac{0.94}{3} = 313 \Omega$$

To make  $R_O = 333 \Omega$ , we add a series resistance of approximately 20  $\Omega$ , as shown below,

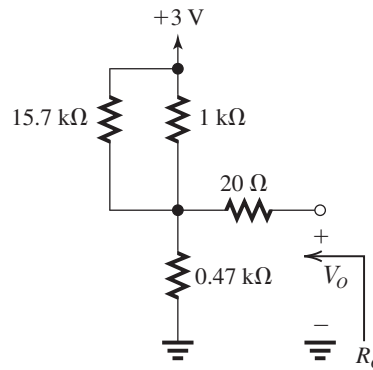

1.10

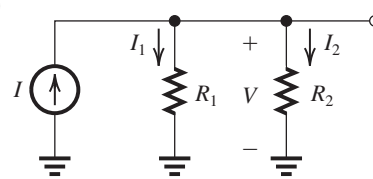

$$V = I(R_1 \parallel R_2)$$

$$= I \frac{R_1 R_2}{R_1 + R_2}$$

$$I_1 = \frac{V}{R_1} = I \frac{R_2}{R_1 + R_2}$$

$$I_2 = \frac{V}{R_2} = I \frac{R_1}{R_1 + R_2}$$

1.11 The parallel combination of the resistors is  $R_{||}$  where

$$\frac{1}{R_{\parallel}} = \sum_{i=1}^N 1/R_i$$

The voltage across them is

$$V = I \times R_{\parallel} = \frac{I}{\sum_{i=1}^N 1/R_i}$$

Thus, the current in resistor  $R_k$  is

$$I_k = V/R_k = \frac{I/R_k}{\sum_{i=1}^N 1/R_i}$$

**1.12** Connect a resistor  $R$  in parallel with  $R_L$ . To make  $I_L = I/4$  (and thus the current through  $R$ ,  $3I/4$ ),  $R$  should be such that

$$6I/4 = 3IR/4 \\ \Rightarrow R = 2 \text{ k}\Omega$$

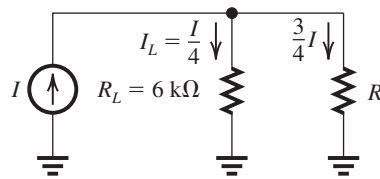

**1.13**

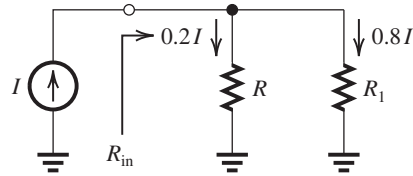

To make the current through  $R$  equal to  $0.2I$ , we shunt  $R$  by a resistance  $R_1$  having a value such that the current through it will be  $0.8I$ ; thus

$$0.2IR = 0.8IR_1 \Rightarrow R_1 = \frac{R}{4}$$

The input resistance of the divider,  $R_{in}$ , is

$$R_{in} = R \parallel R_1 = R \parallel \frac{R}{4} = \frac{1}{5}R$$

Now if  $R_1$  is 10% too high, that is, if

$$R_1 = 1.1 \frac{R}{4}$$

the problem can be solved in two ways:

(a) Connect a resistor  $R_2$  across  $R_1$  of value such that  $R_2 \parallel R_1 = R/4$ , thus

$$\frac{R_2(1.1R/4)}{R_2 + (1.1R/4)} = \frac{R}{4}$$

$$1.1R_2 = R_2 + \frac{1.1R}{4}$$

$$\Rightarrow R_2 = \frac{11R}{4} = 2.75R$$

$$R_{in} = R \parallel \frac{1.1R}{4} \parallel \frac{11R}{4} \\ = R \parallel \frac{R}{4} = \frac{R}{5}$$

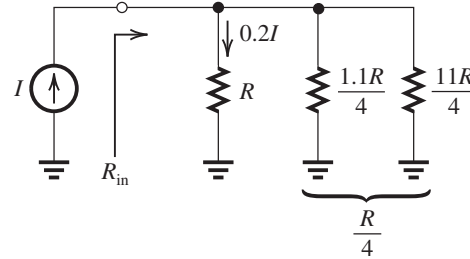

(b) Connect a resistor in series with the load resistor  $R$  so as to raise the resistance of the load branch by 10%, thereby restoring the current division ratio to its desired value. The added series resistance must be 10% of  $R$  (i.e.,  $0.1R$ ).

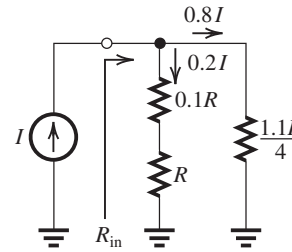

$$R_{in} = 1.1R \parallel \frac{1.1R}{4} \\ = \frac{1.1R}{5}$$

that is, 10% higher than in case (a).

**1.14** The source current is

$$i_s = 0.5 \sin \omega t \text{ mA}$$

having peak amplitude

$$I_s = 0.5 \text{ mA}$$

To ensure a peak voltage across the source of  $V_{s,\max} = 1 \text{ V}$ , a load must be connected with maximum value

$$R_{L,\max} = V_{s,\max}/I_s = 0.5/1 = 2 \text{ k}\Omega$$

If  $R_L = 10 \text{ k}\Omega$ , a second resistor  $R$  must be connected in parallel so that

$$R \parallel R_L = 2 \text{ k}\Omega$$

$$\Rightarrow \frac{1}{R} + \frac{1}{10} = \frac{1}{2}$$

$$\Rightarrow R = \frac{1}{1/2 - 1/10} = 2.5 \text{ k}\Omega$$

In this case,

$$I_L = I_s \times \frac{R}{R_L + R}$$

$$= 0.5 \times \frac{2.5}{10 + 2.5}$$

$$= 0.1 \text{ mA}$$

Thus,  $i_L = 0.1 \sin \omega t \text{ mA}$ .

1.15 (a) Between terminals 1 and 2:

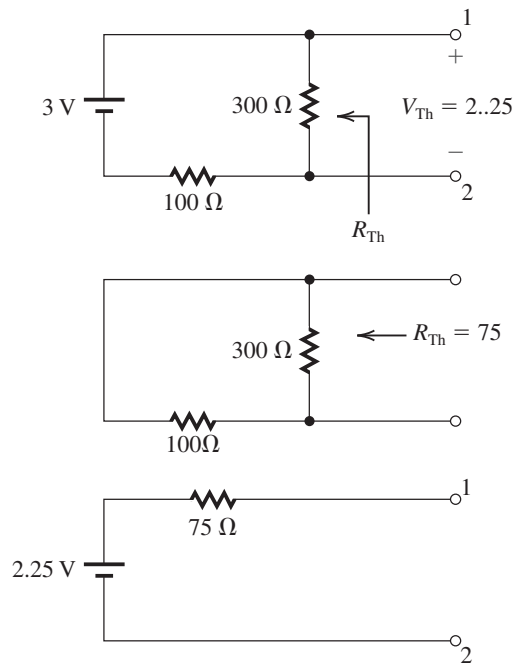

(b) Same procedure is used for (b) to obtain

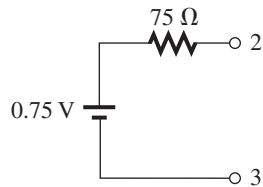

(c) Between terminals 1 and 3, the open-circuit voltage is 3 V. When we short-circuit the voltage source, we see that the Thévenin resistance will be zero. The equivalent circuit is then

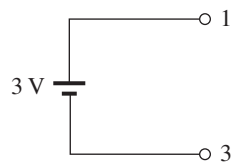

1.16

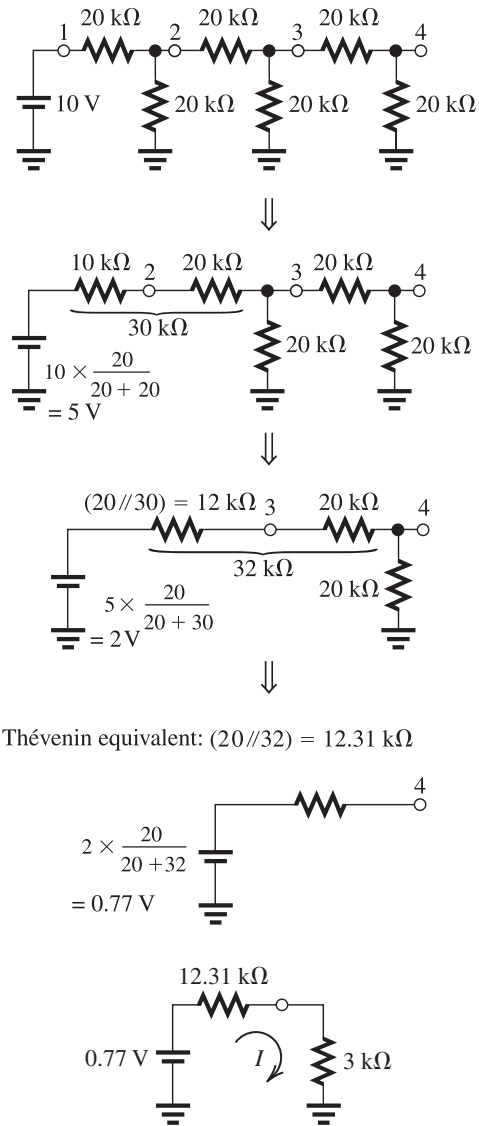

Thévenin equivalent:  $(20 // 32) = 12.31 \text{ k}\Omega$

Now, when a resistance of  $3 \text{ k}\Omega$  is connected between node 4 and ground,

$$I = \frac{0.77}{12.31 + 3}$$

$$= 0.05 \text{ mA}$$

1.17 (a) Node equation at the common mode yields

$$I_3 = I_1 + I_2$$

Using the fact that the sum of the voltage drops across  $R_1$  and  $R_3$  equals 10 V, we write

$$10 = I_1 R_1 + I_3 R_3$$

$$= 10 I_1 + (I_1 + I_2) \times 2$$

$$= 12 I_1 + 2 I_2$$

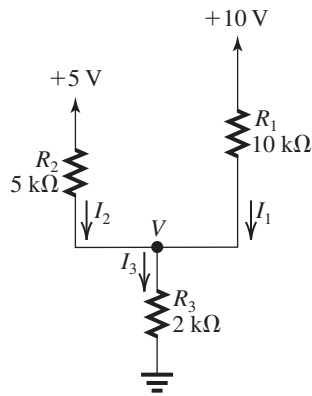

That is,

$$12I_1 + 2I_2 = 10 \quad (1)$$

Similarly, the voltage drops across  $R_2$  and  $R_3$  add up to 5 V, thus

$$\begin{aligned} 5 &= I_2R_2 + I_3R_3 \\ &= 5I_2 + (I_1 + I_2) \times 2 \end{aligned}$$

which yields

$$2I_1 + 7I_2 = 5 \quad (2)$$

Equations (1) and (2) can be solved together by multiplying Eq. (2) by 6:

$$12I_1 + 42I_2 = 30 \quad (3)$$

Now, subtracting Eq. (1) from Eq. (3) yields

$$40I_2 = 20$$

$$\Rightarrow I_2 = 0.5 \text{ mA}$$

Substituting in Eq. (2) gives

$$2I_1 = 5 - 7 \times 0.5 \text{ mA}$$

$$\Rightarrow I_1 = 0.75 \text{ mA}$$

$$I_3 = I_1 + I_2$$

$$= 0.75 + 0.5$$

$$= 1.25 \text{ mA}$$

$$V = I_3R_3$$

$$= 1.25 \times 2 = 2.5 \text{ V}$$

To summarize:

$$I_1 = 0.75 \text{ mA} \quad I_2 = 0.5 \text{ mA}$$

$$I_3 = 1.25 \text{ mA} \quad V = 2.5 \text{ V}$$

(b) A node equation at the common node can be written in terms of  $V$  as

$$\frac{10 - V}{R_1} + \frac{5 - V}{R_2} = \frac{V}{R_3}$$

Thus,

$$\frac{10 - V}{10} + \frac{5 - V}{5} = \frac{V}{2}$$

$$\Rightarrow 0.8V = 2$$

$$\Rightarrow V = 2.5 \text{ V}$$

Now,  $I_1$ ,  $I_2$ , and  $I_3$  can be easily found as

$$I_1 = \frac{10 - V}{10} = \frac{10 - 2.5}{10}$$

$$= 0.75 \text{ mA}$$

$$I_2 = \frac{5 - V}{5} = \frac{5 - 2.5}{5}$$

$$= 0.5 \text{ mA}$$

$$I_3 = \frac{V}{R_3} = \frac{2.5}{2} = 1.25 \text{ mA}$$

Method (b) is much preferred, being faster, more insightful, and less prone to errors. In general, one attempts to identify the lowest possible number of variables and write the corresponding minimum number of equations.

**1.18** Find the Thévenin equivalent of the circuit to the left of node 1.

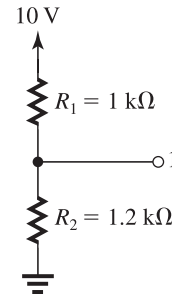

Between node 1 and ground,

$$R_{\text{Th}} = (1 \text{ k}\Omega \parallel 1.2 \text{ k}\Omega) = 0.545 \text{ k}\Omega$$

$$V_{\text{Th}} = 10 \times \frac{1.2}{1 + 1.2} = 5.45 \text{ V}$$

Find the Thévenin equivalent of the circuit to the right of node 2.

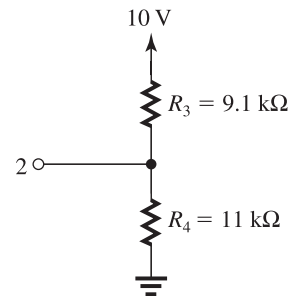

Between node 2 and ground,

$$R_{Th} = 9.1 \text{ k}\Omega \parallel 11 \text{ k}\Omega = 4.98 \text{ k}\Omega$$

$$V_{Th} = 10 \times \frac{11}{11 + 9.1} = 5.47 \text{ V}$$

The resulting simplified circuit is

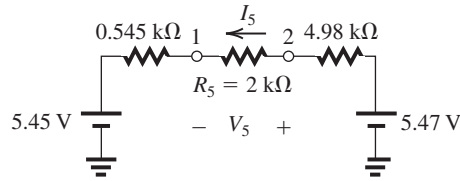

$$I_5 = \frac{5.47 - 5.45}{4.98 + 2 + 0.545}$$

$$= 2.66 \text{ }\mu\text{A}$$

$$V_5 = 2.66 \text{ }\mu\text{A} \times 2 \text{ k}\Omega$$

$$= 5.32 \text{ mV}$$

**1.19** We first find the Thévenin equivalent of the source to the right of  $v_o$ .

$$V = 4 \times 1 = 4 \text{ V}$$

Then, we may redraw the circuit in Fig. P1.19 as shown below

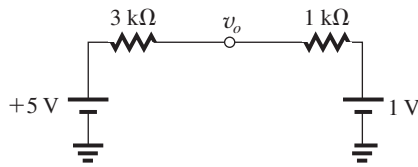

Then, the voltage at  $v_o$  is found from a simple voltage division.

$$v_o = 1 + (5 - 1) \times \frac{1}{3 + 1} = 2 \text{ V}$$

**1.20** Refer to Fig. P1.20. Using the voltage divider rule at the input side, we obtain

$$\frac{v_\pi}{v_s} = \frac{r_\pi}{r_\pi + R_s} \quad (1)$$

At the output side, we find  $v_o$  by multiplying the current  $g_m v_\pi$  by the parallel equivalent of  $r_o$  and  $R_L$ ,

$$v_o = -g_m v_\pi (r_o \parallel R_L) \quad (2)$$

Finally,  $v_o/v_s$  can be obtained by combining Eqs. (1) and (2) as

$$\frac{v_o}{v_s} = -\frac{r_\pi}{r_\pi + R_s} g_m (r_o \parallel R_L)$$

**1.21** (a)  $T = 10^{-4} \mu\text{s} = 10^{-11} \text{ s}$

$$f = \frac{1}{T} = 10^{11} \text{ Hz}$$

$$\omega = 2\pi f = 6.28 \times 10^{11} \text{ rad/s}$$

(b)  $f = 3 \text{ GHz} = 3 \times 10^9 \text{ Hz}$

$$T = \frac{1}{f} = 3.33 \times 10^{-10} \text{ s}$$

$$\omega = 2\pi f = 1.88 \times 10^{10} \text{ rad/s}$$

(c)  $\omega = 6.28 \times 10^4 \text{ rad/s}$

$$f = \frac{\omega}{2\pi} = 10^4 \text{ Hz}$$

$$T = \frac{1}{f} = 10^{-4} \text{ s}$$

(d)  $T = 10^{-7} \text{ s}$

$$f = \frac{1}{T} = 10^7 \text{ Hz}$$

$$\omega = 2\pi f = 6.28 \times 10^7 \text{ rad/s}$$

(e)  $f = 60 \text{ Hz}$

$$T = \frac{1}{f} = 1.67 \times 10^{-2} \text{ s}$$

$$\omega = 2\pi f = 3.77 \times 10^2 \text{ rad/s}$$

(f)  $\omega = 100 \text{ krad/s} = 10^5 \text{ rad/s}$

$$f = \frac{\omega}{2\pi} = 1.59 \times 10^4 \text{ Hz}$$

$$T = \frac{1}{f} = 6.28 \times 10^{-5} \text{ s}$$

(g)  $f = 270 \text{ MHz} = 2.7 \times 10^8 \text{ Hz}$

$$T = \frac{1}{f} = 3.70 \times 10^{-9} \text{ s}$$

$$\omega = 2\pi f = 1.696 \times 10^9 \text{ rad/s}$$

**1.22** (a)  $Z = 1 \text{ k}\Omega$  at all frequencies

(b)  $Z = 1/j\omega C = -j \frac{1}{2\pi f \times 10 \times 10^{-9}}$

At  $f = 60 \text{ Hz}$ ,  $Z = -j265 \text{ k}\Omega$

At  $f = 100 \text{ kHz}$ ,  $Z = -j159 \text{ }\Omega$

At  $f = 1 \text{ GHz}$ ,  $Z = -j0.016 \text{ }\Omega$

(c)  $Z = 1/j\omega C = -j \frac{1}{2\pi f \times 10 \times 10^{-12}}$

At  $f = 60 \text{ Hz}$ ,  $Z = -j0.265 \text{ G}\Omega$

At  $f = 100 \text{ kHz}$ ,  $Z = -j0.16 \text{ M}\Omega$

At  $f = 1 \text{ GHz}$ ,  $Z = -j15.9 \text{ }\Omega$

(d)  $Z = j\omega L = j2\pi f L = j2\pi f \times 10 \times 10^{-3}$

At  $f = 60 \text{ Hz}$ ,  $Z = j3.77 \text{ }\Omega$

At  $f = 100 \text{ kHz}$ ,  $Z = j6.28 \text{ k}\Omega$

At  $f = 1 \text{ GHz}$ ,  $Z = j62.8 \text{ M}\Omega$

$$(e) Z = j\omega L = j2\pi fL = j2\pi f(1 \times 10^{-6})$$

$$f = 60 \text{ Hz}, \quad Z = j0.377 \text{ m}\Omega$$

$$f = 100 \text{ kHz}, \quad Z = j0.628 \Omega$$

$$f = 1 \text{ GHz}, \quad Z = j6.28 \text{ k}\Omega$$

$$\begin{aligned} 1.23 \text{ (a)} \quad Z &= R + \frac{1}{j\omega C} \\ &= 10^3 + \frac{1}{j2\pi \times 10 \times 10^3 \times 10^{-9}} \\ &= (1 - j15.9) \text{ k}\Omega \end{aligned}$$

$$\begin{aligned} \text{(b)} \quad Y &= \frac{1}{R} + j\omega C \\ &= \frac{1}{10^3} + j2\pi \times 10 \times 10^3 \times 0.01 \times 10^{-6} \\ &= 10^{-3}(1 + j0.628) \Omega \\ Z &= \frac{1}{Y} = \frac{10^3}{1 + j0.628} \\ &= \frac{10^3(1 - j0.628)}{1 + 0.628^2} \\ &= (717 - j450) \Omega \end{aligned}$$

$$\begin{aligned} \text{(c)} \quad Y &= \frac{1}{R} + j\omega C \\ &= \frac{1}{10 \times 10^3} + j2\pi \times 10 \times 10^3 \times 100 \times 10^{-12} \\ &= 10^{-4}(1 + j0.0628) \\ Z &= \frac{10^4}{1 + j0.0628} \\ &= (9.96 - j0.626) \text{ k}\Omega \end{aligned}$$

$$\begin{aligned} \text{(d)} \quad Z &= R + j\omega L \\ &= 100 \times 10^3 + j2\pi \times 10 \times 10^3 \times 10 \times 10^{-3} \\ &= 10^5 + j6.28 \times 100 \\ &= (10^5 + j628) \Omega \end{aligned}$$

$$\begin{aligned} 1.24 \quad Y &= \frac{1}{j\omega L} + j\omega C \\ &= \frac{1 - \omega^2 LC}{j\omega L} \end{aligned}$$

$$\Rightarrow Z = \frac{1}{Y} = \frac{j\omega L}{1 - \omega^2 LC}$$

The frequency at which  $|Z| = \infty$  is found letting the denominator equal zero:

$$1 - \omega^2 LC = 0$$

$$\Rightarrow \omega = \frac{1}{\sqrt{LC}}$$

At frequencies just below this,  $\angle Z = +90^\circ$ .

At frequencies just above this,  $\angle Z = -90^\circ$ .

Since the impedance is infinite at this frequency, the current drawn from an ideal voltage source is zero.

## 1.25

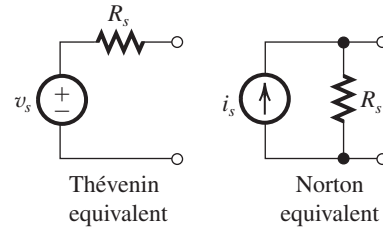

$$v_{oc} = v_s$$

$$i_{sc} = i_s$$

$$v_s = i_s R_s$$

Thus,

$$R_s = \frac{v_{oc}}{i_{sc}}$$

$$\text{(a)} \quad v_s = v_{oc} = 3 \text{ V}$$

$$i_s = i_{sc} = 3 \text{ mA}$$

$$R_s = \frac{v_{oc}}{i_{sc}} = \frac{1 \text{ V}}{3 \text{ mA}} = 1 \text{ k}\Omega$$

$$\text{(b)} \quad v_s = v_{oc} = 0.5 \text{ V}$$

$$i_s = i_{sc} = 50 \mu\text{A}$$

$$R_s = \frac{v_{oc}}{i_{sc}} = \frac{0.5 \text{ V}}{50 \mu\text{A}} = 0.1 \text{ M}\Omega = 10 \text{ k}\Omega$$

## 1.26

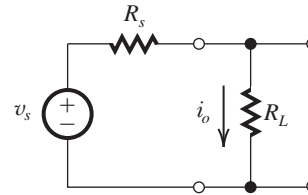

$$\frac{i_o}{v_s} = \frac{1}{R_L + R_s}$$

$$\Rightarrow v_s = i_o (R_L + R_s)$$

Thus,

$$v_s = 10^{-4} \times (10^5 + R_s) = 10 + 10^{-4} \times R_s \quad (1)$$

and,

$$v_s = 5 \times 10^{-4} (10^4 + R_s) = 5 + 5 \times 10^{-4} \times R_s \quad (2)$$

Subtracting equation (2) from equation (1) gives

$$0 = 5 - 4 \times 10^{-4} \times R_s$$

$$\Rightarrow R_s = \frac{5}{4 \times 10^{-4}} = 12.5 \text{ k}\Omega$$

Substituting into equation (1),

$$v_s = 10 + 10^{-4} \times 12.5 \times 10^3 = 11.25 \text{ V}$$

Finally, the Norton equivalent source is found as follows,

$$i_s = v_s / R_s = 900 \mu\text{A}$$

1.27

$$\begin{aligned}
 P_L &= v_o^2 \times \frac{1}{R_L} \\
 &= v_s^2 \frac{R_L^2}{(R_L + R_S)^2} \times \frac{1}{R_L} \\
 &= v_s^2 \frac{R_L}{(R_L + R_S)^2}
 \end{aligned}$$

Since we are told that the power delivered to a  $16\Omega$  speaker load is 75% of the power delivered to a  $32\Omega$  speaker load,

$$\begin{aligned}
 P_L(R_L = 16\Omega) &= 0.75 \times P_L(R_L = 32\Omega) \\
 \frac{16}{(R_S + 32)^2} &= 0.75 \times \frac{32}{(R_S + 32)^2} \\
 \frac{\sqrt{16}}{R_S + 32} &= \frac{\sqrt{24}}{R_S + 32} \\
 \Rightarrow (\sqrt{24} = \sqrt{16})R_S &= \sqrt{16} \times 32 - \sqrt{24} \times 16 \\
 0.9R_S &= 49.6 \\
 R_S &= 55.2\Omega
 \end{aligned}$$

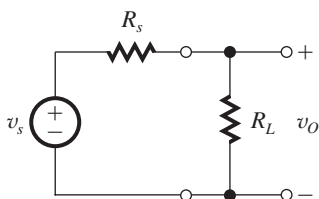

1.28 The observed output voltage is  $0.5 \text{ mV}/^\circ\text{C}$ , which is one quarter the voltage specified by the sensor, presumably under open-circuit conditions: that is, without a load connected. It follows that that sensor internal resistance must be equal to 3 times  $R_L$ , that is,  $30 \text{ k}\Omega$ .

1.29

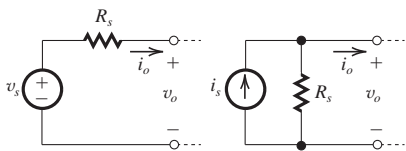

$$v_o = v_s - i_o R_s$$

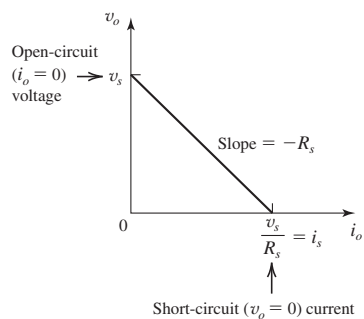

1.30 The nominal values of  $V_L$  and  $I_L$  are given by

$$V_L = \frac{R_L}{R_S + R_L} V_S$$

$$I_L = \frac{V_S}{R_S + R_L}$$

After a 10% increase in  $R_L$ , the new values will be

$$V_L = \frac{1.1R_L}{R_S + 1.1R_L} V_S$$

$$I_L = \frac{V_S}{R_S + 1.1R_L}$$

(a) The nominal values are

$$V_L = \frac{200}{5 + 200} \times 1 = 0.976 \text{ V}$$

$$I_L = \frac{1}{5 + 200} = 4.88 \mu\text{A}$$

After a 10% increase in  $R_L$ , the new values will be

$$V_L = \frac{1.1 \times 200}{5 + 1.1 \times 200} = 0.978 \text{ V}$$

$$I_L = \frac{1}{5 + 1.1 \times 200} = 4.44 \mu\text{A}$$

These values represent a 2% and 9% change, respectively. Since the load voltage remains relatively more constant than the load current, a Thévenin source is more appropriate here.

(b) The nominal values are

$$V_L = \frac{50}{5 + 50} \times 1 = 0.909 \text{ V}$$

$$I_L = \frac{1}{5 + 50} = 18.18 \text{ mA}$$

After a 10% increase in  $R_L$ , the new values will be

$$V_L = \frac{1.1 \times 50}{5 + 1.1 \times 50} = 0.917 \text{ V}$$

$$I_L = \frac{1}{5 + 1.1 \times 50} = 16.67 \text{ mA}$$

These values represent a 1% and 8% change, respectively. Since the load voltage remains relatively more constant than the load current, a Thévenin source is more appropriate here.

(c) The nominal values are

$$V_L = \frac{0.1}{2 + 0.1} \times 1 = 47.6 \text{ mV}$$

$$I_L = \frac{1}{2 + 0.1} = 0.476 \text{ mA}$$

After a 10% increase in  $R_L$ , the new values will be

$$V_L = \frac{1.1 \times 0.1}{2 + 1.1 \times 0.1} = 52.1 \text{ mV}$$

$$I_L = \frac{1}{2 + 1.1 \times 0.1} = 0.474 \text{ mA}$$

These values represent a 9% and 0.4% change, respectively. Since the load current remains

relatively more constant than the load voltage, a Norton source is more appropriate here. The Norton equivalent current source is

$$I_S = \frac{V_S}{R_S} = \frac{1}{2} = 0.5 \text{ mA}$$

(d) The nominal values are

$$V_L = \frac{16}{150 + 16} \times 1 = 96.4 \text{ mV}$$

$$I_L = \frac{1}{150 + 16} = 6.02 \text{ mA}$$

After a 10% increase in  $R_L$ , the new values will be

$$V_L = \frac{1.1 \times 16}{150 + 1.1 \times 16} = 105 \text{ mV}$$

$$I_L = \frac{1}{150 + 1.1 \times 16} = 5.97 \text{ mA}$$

These values represent a 9% and 1% change, respectively. Since the load current remains relatively more constant than the load voltage, a Norton source is more appropriate here. The Norton equivalent current source is

$$I_S = \frac{V_S}{R_S} = \frac{1}{150} = 6.67 \text{ mA}$$

**1.31**

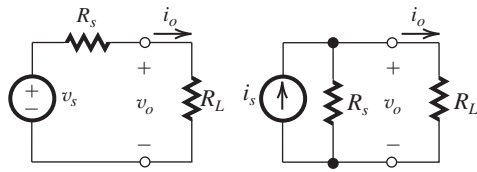

$R_L$  represents the input resistance of the processor

For  $v_o = 0.95v_s$

$$0.95 = \frac{R_L}{R_L + R_S} \Rightarrow R_L = 19R_S$$

For  $i_o = 0.95i_s$

$$0.95 = \frac{R_S}{R_S + R_L} \Rightarrow R_L = R_S/19$$

**1.32**

Case	$\omega$ (rad/s)	$f$ (Hz)	$T$ (s)
a	$3.14 \times 10^{10}$	$5 \times 10^9$	$0.2 \times 10^{-9}$
b	$2 \times 10^9$	$3.18 \times 10^8$	$3.14 \times 10^{-9}$
c	$6.28 \times 10^{10}$	$1 \times 10^{10}$	$1 \times 10^{-10}$
d	$3.77 \times 10^2$	60	$1.67 \times 10^{-2}$
e	$6.28 \times 10^4$	$1 \times 10^4$	$1 \times 10^{-4}$
f	$6.28 \times 10^5$	$1 \times 10^5$	$1 \times 10^{-5}$

**1.33** (a)  $V_{\text{peak}} = 117 \times \sqrt{2} = 165 \text{ V}$

(b)  $V_{\text{rms}} = 33.9/\sqrt{2} = 24 \text{ V}$

(c)  $V_{\text{peak}} = 220 \times \sqrt{2} = 311 \text{ V}$

(d)  $V_{\text{peak}} = 220 \times \sqrt{2} = 311 \text{ kV}$

**1.34** (a)  $v = 3 \sin(2\pi \times 20 \times 10^3 t) \text{ V}$

(b)  $v = 120\sqrt{2} \sin(2\pi \times 60) \text{ V}$

(c)  $v = 0.1 \sin(10^8 t) \text{ V}$

(d)  $v = 0.1 \sin(2\pi \times 10^9 t) \text{ V}$

**1.35** The waveform is symmetrical, and therefore has an average value of 0 V. Its lowest and highest values are -1 V and +1 V respectively. Its frequency is  $1/0.5 \text{ ms} = 2 \text{ kHz}$ . It may be expressed as a sum of sinusoids using Eq. (1.2),

$$\frac{1}{\pi} \left( \sin 2\pi \times 2000t + \frac{1}{3} \sin 6\pi \times 2000t + \frac{1}{5} \sin 10\pi \times 2000t + \dots \right) \text{ V}$$

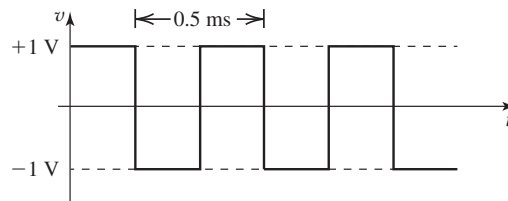

**1.36** The two harmonics have the ratio  $126/98 = 9/7$ . Thus, these are the 7th and 9th harmonics. From Eq. (1.2), we note that the amplitudes of these two harmonics will have the ratio 7 to 9, which is confirmed by the measurement reported. Thus the fundamental will have a frequency of  $98/7$ , or 14 kHz, and peak amplitude of  $63 \times 7 = 441 \text{ mV}$ . The rms value of the fundamental will be  $441/\sqrt{2} = 312 \text{ mV}$ . To find the peak-to-peak amplitude of the square wave, we note that  $4V/\pi = 441 \text{ mV}$ . Thus,

Peak-to-peak amplitude

$$= 2V = 441 \times \frac{\pi}{2} = 693 \text{ mV}$$

$$\text{Period } T = \frac{1}{f} = \frac{1}{14 \times 10^3} = 71.4 \mu\text{s}$$

**1.37** The rms value of a symmetrical square wave with peak amplitude  $\hat{V}$  is simply  $\hat{V}$ . Taking the root-mean-square of the first 5 sinusoidal terms in Eq. (1.2) gives an rms value of,

$$\frac{4\hat{V}}{\pi\sqrt{2}} \sqrt{1^2 + \left(\frac{1}{3}\right)^2 + \left(\frac{1}{5}\right)^2 + \left(\frac{1}{7}\right)^2 + \left(\frac{1}{9}\right)^2} = 0.980\hat{V}$$

which is 2% lower than the rms value of the square wave.

**1.38** If the amplitude of the square wave is  $V_{sq}$ , then the power delivered by the square wave to a resistance  $R$  will be  $V_{sq}^2/R$ . If this power is to be equal to that delivered by a sine wave of peak amplitude  $\hat{V}$ , then

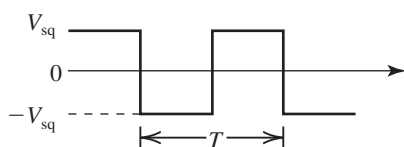

$$\frac{V_{sq}^2}{R} = \frac{(\hat{V}/\sqrt{2})^2}{R}$$

Thus,  $V_{sq} = \hat{V}/\sqrt{2}$ . This result is independent of frequency.

**1.39**

Decimal	Binary
0	0
5	101
13	1101
32	10000
63	111111

**1.40**

$b_3$	$b_2$	$b_1$	$b_0$	Value Represented
0	0	0	0	+0
0	0	0	1	+1
0	0	1	0	+2
0	0	1	1	+3
0	1	0	0	+4
0	1	0	1	+5
0	1	1	0	+6
0	1	1	1	+7
1	0	0	0	-0
1	0	0	1	-1
1	0	1	0	-2
1	0	1	1	-3
1	1	0	0	-4
1	1	0	1	-5
1	1	1	0	-6
1	1	1	1	-7

Note that there are two possible representations of zero: 0000 and 1000. For a 0.5-V step size,

analog signals in the range  $\pm 3.5$  V can be represented.

Input	Steps	Code
+2.5 V	+5	0101
-3.0 V	-6	1110
+2.7	+5	0101
-2.8	-6	1110

**1.41** (a) An  $N$ -bit DAC produces  $2^N$  discrete equally spaced levels over a range of  $V_{FS} - 0 = V_{FS}$ . Thus, the levels are spaced

$$V_{LSB} = \frac{V_{FS}}{(2^N - 1)} \tag{1}$$

(b) Any voltage within the range 0 to  $V_{FS}$  can be approximated by the nearest DAC output level, which will be up to  $V_{LSB}/2$  above or below the desired voltage. Thus, the maximum quantization error of the converter is

$$V_{LSB}/2 = V_{FS}/2(2^N - 1).$$

(c) To obtain a resolution of 2 mV or less, using Eq. (1)

$$0.002 \leq \frac{5}{(2^N - 1)}$$

$$\Rightarrow N \geq \log_2 \left( \frac{5}{0.002} + 1 \right) = 11.3$$

Taking the minimum integer satisfying this condition, we require a 12-bit DAC which provides a resolution of

$$V_{LSB} = \frac{5}{2^{12} - 1} = 1.22 \text{ mV}$$

**1.42** (a) When  $b_i = 1$ , the  $i$ th switch is in position 1 and a current  $(V_{ref}/2^i R)$  flows to the output. Thus  $i_O$  will be the sum of all the currents corresponding to "1" bits, that is,

$$i_O = \frac{V_{ref}}{R} \left( \frac{b_1}{2^1} + \frac{b_2}{2^2} + \dots + \frac{b_N}{2^N} \right)$$

(b)  $b_N$  is the LSB

$b_1$  is the MSB

$$(c) i_{Omax} = \frac{10 \text{ V}}{10 \text{ k}\Omega} \left( \frac{1}{2^1} + \frac{1}{2^2} + \frac{1}{2^3} + \frac{1}{2^4} + \frac{1}{2^5} + \frac{1}{2^6} + \frac{1}{2^7} + \frac{1}{2^8} \right)$$

$$= 0.99609375 \text{ mA}$$

Corresponding to the LSB changing from 0 to 1 the output changes by  $(10/10) \times 1/2^8 = 3.91 \mu\text{A}$ .

**1.43** There will be 44,100 samples per second with each sample represented by 16 bits. Thus the

throughput or speed will be  $44, 100 \times 16 = 7.056 \times 10^5$  bits per second.

**1.44** Each pixel requires  $8 + 8 + 8 = 24$  bits to represent it. We will approximate a megapixel as  $10^6$  pixels, and a Gbit as  $10^9$  bits. Thus, each image requires  $24 \times 10 \times 10^6 = 2.4 \times 10^8$  bits. The number of such images that fit in 16 Gbits of memory is

$$\lfloor \frac{2.4 \times 10^8}{16 \times 10^9} \rfloor = \lfloor 66.7 \rfloor = 66$$

**1.45** (a)  $A_v = \frac{v_o}{v_i} = \frac{10 \text{ V}}{100 \text{ mV}} = 100 \text{ V/V}$

or  $20 \log 100 = 40 \text{ dB}$

$$A_i = \frac{i_o}{i_i} = \frac{v_o/R_L}{i_i} = \frac{10 \text{ V}/100 \Omega}{100 \mu\text{A}} = \frac{0.1 \text{ A}}{100 \mu\text{A}}$$

$$= 1000 \text{ A/A}$$

or  $20 \log 1000 = 60 \text{ dB}$

$$A_p = \frac{v_o i_o}{v_i i_i} = \frac{v_o}{v_i} \times \frac{i_o}{i_i} = 100 \times 1000$$

$$= 10^5 \text{ W/W}$$

or  $10 \log 10^5 = 50 \text{ dB}$

(b)  $A_v = \frac{v_o}{v_i} = \frac{1 \text{ V}}{10 \mu\text{V}} = 1 \times 10^5 \text{ V/V}$

or  $20 \log 1 \times 10^5 = 100 \text{ dB}$

$$A_i = \frac{i_o}{i_i} = \frac{v_o/R_L}{i_i} = \frac{1 \text{ V}/10 \text{ k}\Omega}{100 \text{ nA}}$$

$$= \frac{0.1 \text{ mA}}{100 \text{ nA}} = \frac{0.1 \times 10^{-3}}{100 \times 10^{-9}} = 1000 \text{ A/A}$$

or  $20 \log A_i = 60 \text{ dB}$

$$A_p = \frac{v_o i_o}{v_i i_i} = \frac{v_o}{v_i} \times \frac{i_o}{i_i}$$

$$= 1 \times 10^5 \times 1000$$

$$= 1 \times 10^8 \text{ W/W}$$

or  $10 \log A_p = 80 \text{ dB}$

(c)  $A_v = \frac{v_o}{v_i} = \frac{5 \text{ V}}{1 \text{ V}} = 5 \text{ V/V}$

or  $20 \log 5 = 14 \text{ dB}$

$$A_i = \frac{i_o}{i_i} = \frac{v_o/R_L}{i_i} = \frac{5 \text{ V}/10 \Omega}{1 \text{ mA}}$$

$$= \frac{0.5 \text{ A}}{1 \text{ mA}} = 500 \text{ A/A}$$

or  $20 \log 500 = 54 \text{ dB}$

$$A_p = \frac{v_o i_o}{v_i i_i} = \frac{v_o}{v_i} \times \frac{i_o}{i_i}$$

$$= 5 \times 500 = 2500 \text{ W/W}$$

or  $10 \log A_p = 34 \text{ dB}$

#### 1.46

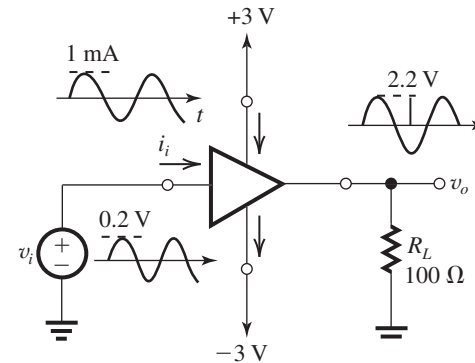

The voltage gain is

$$\frac{V_o}{V_i} = \frac{2.2}{0.2} = 11 \text{ V/V} = 20.8 \text{ dB}$$

The current gain is

$$\frac{I_o}{I_i} = \frac{2.2/0.1}{1.0} = 22 \text{ A/A} = 26.8 \text{ dB}$$

The power gain is

$$\frac{V_o I_o / 2}{V_i I_i / 2} = 11 \times 22 = 242 \text{ W/W} = 23.8 \text{ dB}$$

The supply power is

$$\frac{V_o^2}{2R_L} \times \frac{1}{\eta} = \frac{2.2^2}{2 \times 0.1 \times 0.1} = 242 \text{ mW}$$

Since the power is drawn from  $\pm 3 \text{ V}$  supplies, the supply current must be

$$\frac{242}{3 - (-3)} = 40.3 \text{ mA}$$

The power dissipated in the amplifier is the total power drawn from the supply, less the power dissipated in the load.

$$242 - \frac{2.2^2}{2 \times 0.1} = 217.8 \text{ mW}$$

**1.47** For  $\pm 5 \text{ V}$  supplies:

The largest undistorted sine-wave output is of 4-V peak amplitude or  $4/\sqrt{2} = 2.8 \text{ V}_{\text{rms}}$ . Input needed is  $14 \text{ mV}_{\text{rms}}$ .

For  $\pm 10\text{-V}$  supplies, the largest undistorted sine-wave output is of 9-V peak amplitude or  $6.4 \text{ V}_{\text{rms}}$ . Input needed is  $32 \text{ mV}_{\text{rms}}$ .

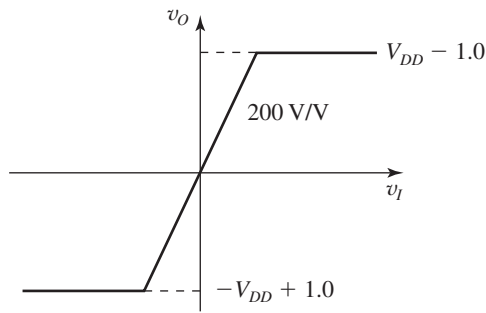

For  $\pm 15\text{-V}$  supplies, the largest undistorted sine-wave output is of  $14\text{-V}$  peak amplitude or  $9.9\text{ V}_{\text{rms}}$ . The input needed is  $9.9\text{ V}/200 = 49.5\text{ mV}_{\text{rms}}$ .

$$\begin{aligned} \mathbf{1.48} \quad v_o &= A_{vo} v_i \frac{R_L}{R_L + R_o} \\ &= A_{vo} \left( v_s \frac{R_i}{R_i + R_s} \right) \frac{R_L}{R_L + R_o} \end{aligned}$$

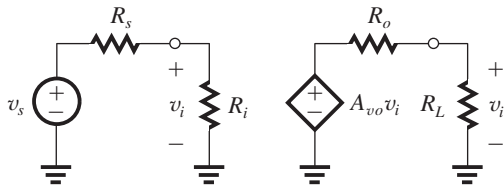

Thus,

$$\begin{aligned} \frac{v_o}{v_s} &= A_{vo} \frac{R_i}{R_i + R_s} \frac{R_L}{R_L + R_o} \\ \text{(a) } A_{vo} &= 100, R_i = 10R_s, R_L = 10R_o \\ \frac{v_o}{v_s} &= 100 \times \frac{10R_s}{10R_s + R_s} \times \frac{10R_o}{10R_o + R_o} \\ &= 82.6\text{ V/V or } 20 \log 82.6 = 38.3\text{ dB} \\ \text{(b) } A_{vo} &= 100, R_i = R_s, R_L = R_o \\ \frac{v_o}{v_s} &= 100 \times \frac{1}{2} \times \frac{1}{2} = 25\text{ V/V or } 20 \log 25 = 28\text{ dB} \\ \text{(c) } A_{vo} &= 100\text{ V/V}, R_i = R_s/10, R_L = R_o/10 \\ \frac{v_o}{v_s} &= 100 \frac{R_s/10}{(R_s/10) + R_s} \frac{R_o/10}{(R_o/10) + R_o} \\ &= 0.826\text{ V/V or } 20 \log 0.826 = -1.7\text{ dB} \end{aligned}$$

**1.49**

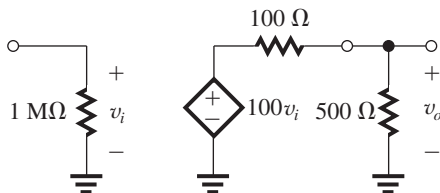

$$20 \log A_{vo} = 40\text{ dB} \Rightarrow A_{vo} = 100\text{ V/V}$$

$$\begin{aligned} A_v &= \frac{v_o}{v_i} \\ &= 100 \times \frac{500}{500 + 100} \\ &= 83.3\text{ V/V} \end{aligned}$$

$$\text{or } 20 \log 83.3 = 38.4\text{ dB}$$

$$A_p = \frac{v_o^2/500\ \Omega}{v_i^2/1\ \text{M}\Omega} = A_v^2 \times 10^4 = 1.39 \times 10^7\text{ W/W}$$

$$\text{or } 10 \log (1.39 \times 10^7) = 71.4\text{ dB.}$$

For a peak output sine-wave current of  $20\text{ mA}$ , the peak output voltage will be  $20\text{ mA} \times 500\ \Omega = 10\text{ V}$ . Correspondingly  $v_i$  will be a sine wave with a peak value of  $10\text{ V}/A_v = 10/83.3$ , or an rms value of  $10/(83.3 \times \sqrt{2}) = 0.085\text{ V}$ . Corresponding output power =  $(10/\sqrt{2})^2/500\ \Omega = 0.1\text{ W}$

**1.50 (a)**

$$\begin{aligned} \frac{v_o}{v_s} &= \frac{v_i}{v_s} \times \frac{v_o}{v_i} \\ &= \frac{1}{5 + 1} \times 100 \times \frac{100}{200 + 100} \\ &= 5.56\text{ V/V} \end{aligned}$$

Much of the amplifier's  $100\text{ V/V}$  gain is lost in the source resistance and amplifier's output resistance. If the source were connected directly to the load, the gain would be

$$\frac{v_o}{v_s} = \frac{0.1}{5 + 0.1} = 0.0196\text{ V/V}$$

This is a factor of  $284\times$  smaller than the gain with the amplifier in place!

(b)

The equivalent current amplifier has a dependent current source with a value of

$$\begin{aligned} \frac{100\text{ V/V}}{200\ \Omega} \times i_i &= \frac{100\text{ V/V}}{200\ \Omega} \times 1000\ \Omega \times v_i \\ &= 500 \times i_i \end{aligned}$$

$$\text{Thus, } \frac{i_o}{i_s} = \frac{i_i}{i_s} \times \frac{i_o}{i_i}$$

$$= \frac{5}{5 + 1} \times 500 \times \frac{200}{200 + 100}$$

$$= 277.8\text{ A/A}$$

Using the voltage amplifier model, the current gain can be found as follows,

$$\begin{aligned} \frac{i_o}{i_s} &= \frac{i_i}{i_s} \times \frac{v_i}{i_i} \times \frac{i_o}{v_i} \\ &= \frac{5}{5 + 1} \times 1000 \times \frac{100\text{ V/V}}{200 + 100} \\ &= 277.8\text{ A/A} \end{aligned}$$

This figure belongs to Problem 1.50.

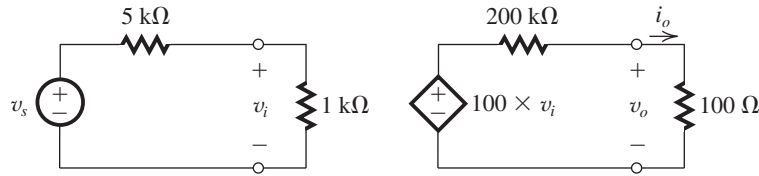

Figure 1

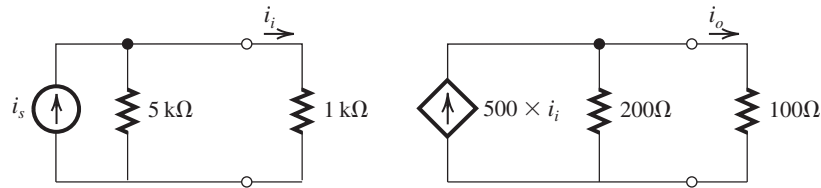
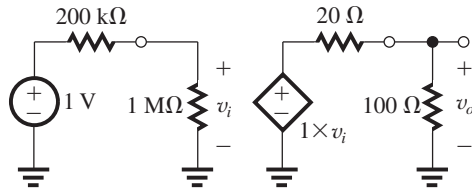

Figure 2

1.51



$$v_o = 1 \text{ V} \times \frac{1 \text{ M}\Omega}{1 \text{ M}\Omega + 200 \text{ k}\Omega} \times 1 \times \frac{100 \Omega}{100 \Omega + 20 \Omega}$$

$$= \frac{1}{1.2} \times \frac{100}{120} = 0.69 \text{ V}$$

$$\text{Voltage gain} = \frac{v_o}{v_s} = 0.69 \text{ V/V or } -3.2 \text{ dB}$$

$$\text{Current gain} = \frac{v_o/100 \Omega}{v_s/1.2 \text{ M}\Omega} = 0.69 \times 1.2 \times 10^4$$

$$= 8280 \text{ A/A or } 78.4 \text{ dB}$$

$$\text{Power gain} = \frac{v_o^2/100 \Omega}{v_s^2/1.2 \text{ M}\Omega} = 5713 \text{ W/W}$$

$$\text{or } 10 \log 5713 = 37.6 \text{ dB}$$

(This takes into account the power dissipated in the internal resistance of the source.)

1.52 In Example 1.3, when the first and the second stages are interchanged, the circuit looks like the figure above, and

$$\frac{v_{i1}}{v_s} = \frac{100 \text{ k}\Omega}{100 \text{ k}\Omega + 100 \text{ k}\Omega} = 0.5 \text{ V/V}$$

$$A_{v1} = \frac{v_{i2}}{v_{i1}} = 100 \times \frac{1 \text{ M}\Omega}{1 \text{ M}\Omega + 1 \text{ k}\Omega} = 99.9 \text{ V/V}$$

$$A_{v2} = \frac{v_{i3}}{v_{i2}} = 10 \times \frac{10 \text{ k}\Omega}{10 \text{ k}\Omega + 1 \text{ k}\Omega} = 9.09 \text{ V/V}$$

$$A_{v3} = \frac{v_L}{v_{i3}} = 1 \times \frac{100 \Omega}{100 \Omega + 10 \Omega} = 0.909 \text{ V/V}$$

$$\text{Total gain} = A_v = \frac{v_L}{v_{i1}} = A_{v1} \times A_{v2} \times A_{v3}$$

$$= 99.9 \times 9.09 \times 0.909 = 825.5 \text{ V/V}$$

The voltage gain from source to load is

$$\frac{v_L}{v_s} = \frac{v_L}{v_{i1}} \times \frac{v_{i1}}{v_s} = A_v \cdot \frac{v_{i1}}{v_s}$$

$$= 825.5 \times 0.5$$

$$= 412.7 \text{ V/V}$$

The overall voltage has reduced appreciably. This is because the input resistance of the first stage,

This figure belongs to Problem 1.52.

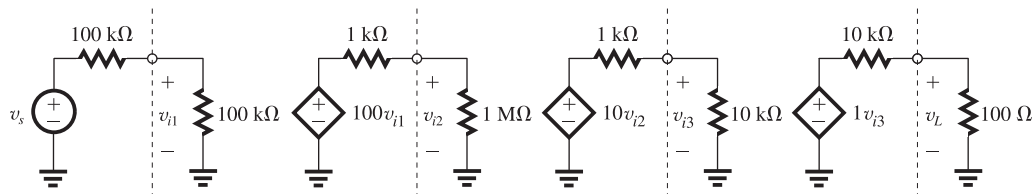

$R_{in}$ , is comparable to the source resistance  $R_s$ . In Example 1.3 the input resistance of the first stage is much larger than the source resistance.

**1.53** (a) Case S-A-B-L (see figure below):

$$\frac{v_o}{v_s} = \frac{v_o}{v_{ib}} \times \frac{v_{ib}}{v_{ia}} \times \frac{v_{ia}}{v_s} = \left(10 \times \frac{100}{100 + 1000}\right) \times \left(100 \times \frac{10}{10 + 10}\right) \times \left(\frac{100}{100 + 100}\right)$$

$$\frac{v_o}{v_s} = 22.7 \text{ V/V and gain in dB } 20 \log 22.7 = 27.1 \text{ dB}$$

(b) Case S-B-A-L (see figure below):

$$\frac{v_o}{v_s} = \frac{v_o}{v_{ia}} \cdot \frac{v_{ia}}{v_{ib}} \cdot \frac{v_{ib}}{v_s} = \left(100 \times \frac{100}{100 + 10 \text{ K}}\right) \times \left(10 \times \frac{100 \text{ K}}{100 \text{ K} + 1 \text{ K}}\right) \times \left(\frac{10 \text{ K}}{10 \text{ K} + 100 \text{ K}}\right)$$

$$\frac{v_o}{v_s} = 0.89 \text{ V/V and gain in dB is } 20 \log 0.89 = -1 \text{ dB. Obviously, case a is preferred because it provides higher voltage gain.}$$

**1.54** Each of stages #1, 2, ..., (n - 1) can be represented by the equivalent circuit:

$$\frac{v_o}{v_s} = \frac{v_{i1}}{v_s} \times \frac{v_{i2}}{v_{i1}} \times \frac{v_{i3}}{v_{i2}} \times \dots \times \frac{v_{in}}{v_{i(n-1)}} \times \frac{v_o}{v_{in}}$$

where

$$\frac{v_{i1}}{v_s} = \frac{100 \text{ k}\Omega}{100 \text{ k}\Omega + 50 \text{ k}\Omega} = 0.667 \text{ V/V}$$

This figure belongs to **1.53**, part (a).

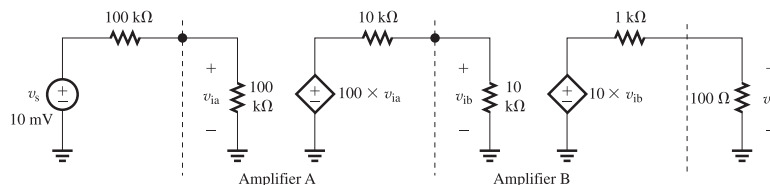

This figure belongs to **1.53**, part (b).

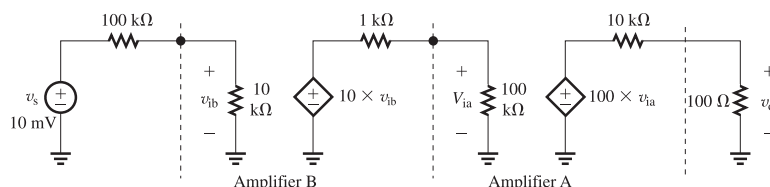

$$\frac{v_o}{v_{in}} = 15 \times \frac{200 \Omega}{1 \text{ k}\Omega + 200 \Omega} = 2.5 \text{ V/V}$$

$$\frac{v_{i2}}{v_{i1}} = \frac{v_{i3}}{v_{i2}} = \dots = \frac{v_{in}}{v_{i(n-1)}} = 15 \times \frac{100 \text{ k}\Omega}{100 \text{ k}\Omega + 1 \text{ k}\Omega}$$

$$= 14.85 \text{ V/V}$$

Thus,

$$\frac{v_o}{v_s} = 0.667 \times (14.85)^{n-1} \times 2.5 = 1.667 \times (14.85)^{n-1}$$

For  $v_s = 5 \text{ mV}$  and  $v_o = 3 \text{ V}$ , the gain  $\frac{v_o}{v_s}$  must be  $\geq 600$ , thus

$$1.667 \times (14.85)^{n-1} \geq 600$$

$$\Rightarrow n = 4$$

Thus four amplifier stages are needed, resulting in

$$\frac{v_o}{v_s} = 1.667 \times (14.85)^3 = 5458 \text{ V/V}$$

and correspondingly

$$v_o = 5458 \times 5 \text{ mV} = 16.37 \text{ V}$$

**1.55** Deliver 0.5 W to a 100-Ω load.

Source is 30 mV rms with 0.5-MΩ source resistance. Choose from these three amplifier types:

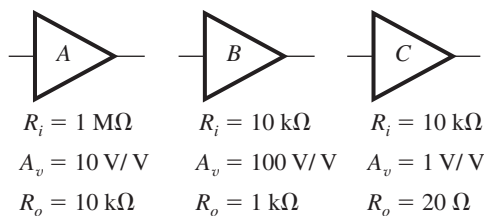

This figure belongs to 1.54.

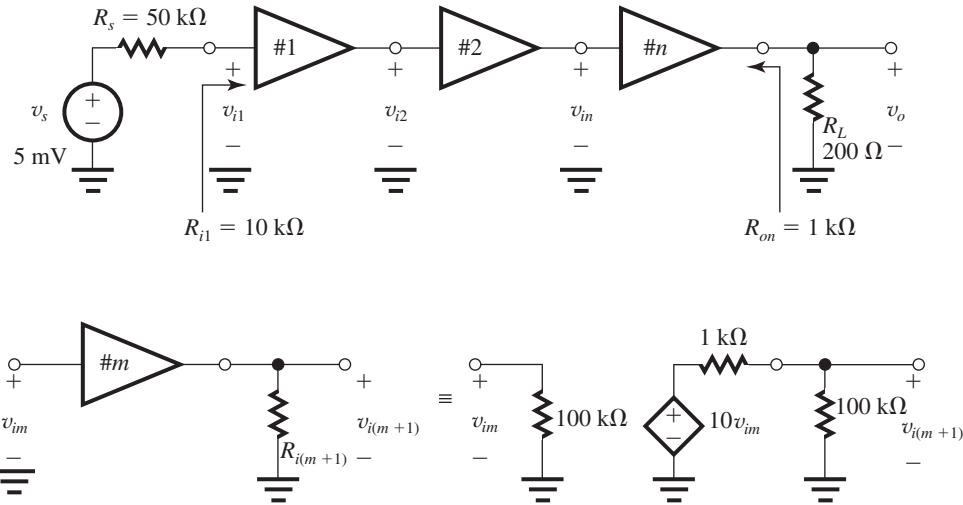

This figure belongs to 1.55.

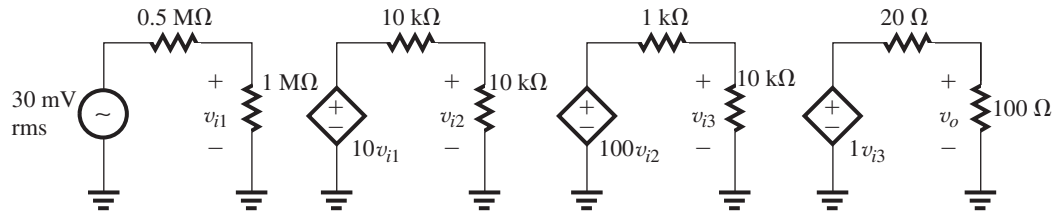

Choose order to eliminate loading on input and output:

- A, first, to minimize loading on 0.5-M $\Omega$  source
  - B, second, to boost gain
  - C, third, to minimize loading at 100- $\Omega$  output.
- We first attempt a cascade of the three stages in the order A, B, C (see figure above), and obtain

$$\frac{v_{i1}}{v_s} = \frac{1 \text{ M}\Omega}{1 \text{ M}\Omega + 0.5 \text{ M}\Omega} = \frac{1}{1.5}$$

$$\Rightarrow v_{i1} = 30 \times \frac{1}{1.5} = 20 \text{ mV}$$

$$\frac{v_{i2}}{v_{i1}} = 10 \times \frac{10 \text{ k}\Omega}{10 \text{ k}\Omega + 10 \text{ k}\Omega} = 5$$

$$\Rightarrow v_{i2} = 20 \times 5 = 100 \text{ mV}$$

$$\frac{v_{i3}}{v_{i2}} = 100 \times \frac{10 \text{ k}\Omega}{10 \text{ k}\Omega + 1 \text{ k}\Omega} = 90.9$$

$$\Rightarrow v_{i3} = 100 \text{ mV} \times 90.9 = 9.09 \text{ V}$$

$$\frac{v_o}{v_{i3}} = 1 \times \frac{100 \Omega}{100 \Omega + 20 \Omega} = 0.833$$

$$\Rightarrow v_o = 9.09 \times 0.833 = 7.6 \text{ V}$$

$$P_o = \frac{v_{o\text{rms}}^2}{R_L} = \frac{7.6^2}{100} = 0.57 \text{ W}$$

which exceeds the required 0.5 W. Also, the signal throughout the amplifier chain never drops below 20 mV (which is greater than the required minimum of 10 mV).

1.56 (a) Required voltage gain  $\equiv \frac{v_o}{v_s}$

$$= \frac{2 \text{ V}}{0.005 \text{ V}} = 400 \text{ V/V}$$

(b) The smallest  $R_i$  allowed is obtained from

$$0.1 \mu\text{A} = \frac{5 \text{ mV}}{R_s + R_i} \Rightarrow R_s + R_i = 50 \text{ k}\Omega$$

Thus  $R_i = 40 \text{ k}\Omega$ .

For  $R_i = 40 \text{ k}\Omega$ ,  $i_i = 0.1 \mu\text{A}$  peak, and

$$\text{Overall current gain} = \frac{v_o/R_L}{i_i} = \frac{2 \text{ V}/1 \text{ k}\Omega}{0.1 \mu\text{A}}$$

$$= \frac{2 \text{ mA}}{0.1 \mu\text{A}} = 2 \times 10^4 \text{ A/A}$$

$$\text{Overall power gain} \equiv \frac{v_{o\text{rms}}^2/R_L}{v_{s\text{rms}} \times i_{i\text{rms}}}$$

$$= \frac{\left(\frac{2}{\sqrt{2}}\right)^2 / 1000}{\left(\frac{5 \times 10^{-3}}{\sqrt{2}}\right) \times \left(\frac{0.1 \times 10^{-6}}{\sqrt{2}}\right)}$$

$$= 8 \times 10^6 \text{ W/W}$$

(This takes into account the power dissipated in the internal resistance of the source.)

(c) If  $(A_{vo}v_i)$  has its peak value limited to 3 V, the largest value of  $R_o$  is found from

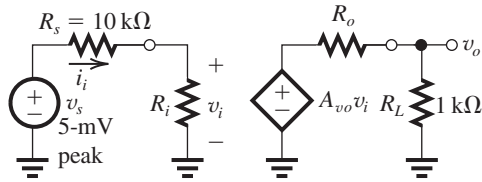

$$= 3 \times \frac{R_L}{R_L + R_o} = 2 \Rightarrow R_o = \frac{1}{2} R_L = 500 \Omega$$

(If  $R_o$  were greater than this value, the output voltage across  $R_L$  would be less than 2 V.)

(d) For  $R_i = 40 \text{ k}\Omega$  and  $R_o = 500 \Omega$ , the required value  $A_{vo}$  can be found from

$$400 \text{ V/V} = \frac{40}{40 + 10} \times A_{vo} \times \frac{1}{1 + 0.5}$$

$$\Rightarrow A_{vo} = 750 \text{ V/V}$$

(e)  $R_i = 100 \text{ k}\Omega (1 \times 10^5 \Omega)$

$$R_o = 100 \Omega (1 \times 10^2 \Omega)$$

$$400 = \frac{100}{100 + 10} \times A_{vo} \times \frac{1000}{1000 + 100}$$

$$\Rightarrow A_{vo} = 484 \text{ V/V}$$

**1.57**

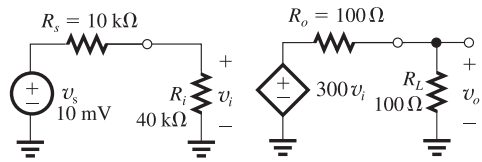

(a)

$$v_o = 10 \text{ mV} \times \frac{40}{40 + 10} \times 300 \times \frac{100}{100 + 100}$$

$$= 1.2 \text{ V}$$

(b)  $\frac{v_o}{v_s} = \frac{1200 \text{ mV}}{10 \text{ mV}} = 120 \text{ V/V}$

(c)  $\frac{v_o}{v_i} = 300 \times \frac{100}{100 + 100} = 150 \text{ V/V}$

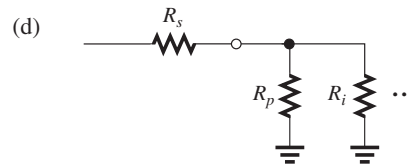

Connect a resistance  $R_p$  in parallel with the input and select its value from

$$\frac{(R_p \parallel R_i)}{(R_p \parallel R_i) + R_s} = \frac{1}{2} \frac{R_i}{R_i + R_s}$$

$$\Rightarrow 1 + \frac{R_s}{R_p \parallel R_i} = 2.5 \Rightarrow R_p \parallel R_i = \frac{R_s}{1.5} = \frac{10}{1.5}$$

$$\Rightarrow \frac{1}{R_p} + \frac{1}{R_i} = \frac{1.5}{10}$$

$$R_p = \frac{1}{0.15 - 0.025} = 8 \text{ k}\Omega$$

**1.58** The equivalent circuit at the output side of a current amplifier loaded with a resistance  $R_L$  is shown. Since

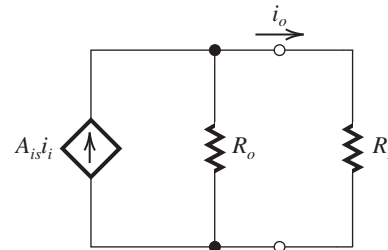

$$i_o = (A_{is} i_i) \frac{R_o}{R_o + R_L}$$

we can write

$$1 = (A_{is} i_i) \frac{R_o}{R_o + 1} \tag{1}$$

and

$$0.5 = (A_{is} i_i) \frac{R_o}{R_o + 12} \tag{2}$$

Dividing Eq. (1) by Eq. (2), we have

$$2 = \frac{R_o + 12}{R_o + 1} \Rightarrow R_o = 10 \text{ k}\Omega$$

$$A_{is} i_i = 1 \times \frac{10 + 1}{10} = 1.1 \text{ mA}$$

**1.59**

The current gain is

$$\frac{i_o}{i_i} = \frac{R_m}{R_o + R_L}$$

$$= \frac{5000}{10 + 1000}$$

$$= 4.95 \text{ A/A} = 13.9 \text{ dB}$$

This figure belongs to Problem 1.59.

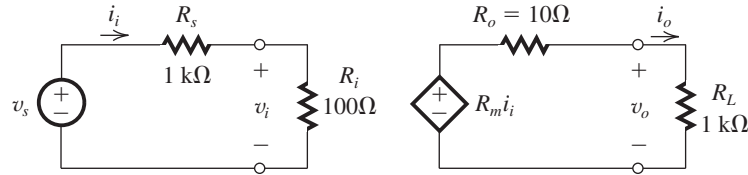

The voltage gain is

$$\begin{aligned} \frac{v_o}{v_s} &= \frac{i_i}{v_s} \times \frac{i_o}{i_i} \times \frac{v_o}{i_o} \\ &= \frac{1}{R_s + R_i} \times \frac{i_o}{i_i} \times R_L \\ &= \frac{1}{1000 + 100} \times 4.95 \times 1000 \\ &= 4.90 \text{ V/V} = 13.8 \text{ dB} \end{aligned}$$

The power gain is

$$\begin{aligned} \frac{v_o i_o}{v_s i_i} &= 4.95 \times 4.90 \\ &= 24.3 \text{ W/W} = 27.7 \text{ dB} \end{aligned}$$

1.60

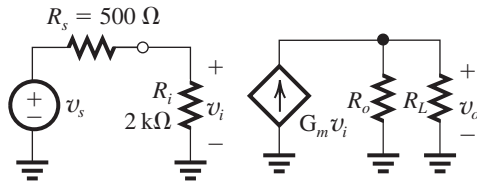

$$G_m = 20 \text{ mA/V}$$

$$R_o = 5 \text{ k}\Omega$$

$$R_L = 1 \text{ k}\Omega$$

$$\begin{aligned} v_i &= v_s \frac{R_i}{R_s + R_i} \\ &= v_s \frac{2}{0.5 + 2} = 0.8 v_s \\ v_o &= G_m v_i (R_L \parallel R_o) \\ &= 20 \frac{5 \times 1}{5 + 1} v_i \\ &= 20 \frac{5}{6} \times 0.8 v_s \end{aligned}$$

$$\text{Overall voltage gain} \equiv \frac{v_o}{v_s} = 13.3 \text{ V/V}$$

1.61 To obtain the weighted sum of  $v_1$  and  $v_2$

$$v_o = 10v_1 + 20v_2$$

we use two transconductance amplifiers and sum their output currents. Each transconductance amplifier has the following equivalent circuit:

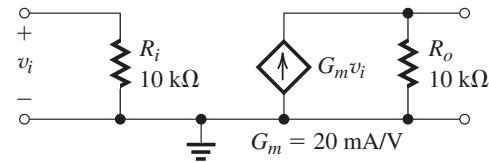

Consider first the path for the signal requiring higher gain, namely  $v_2$ . See figure at top of next page.

The parallel connection of the two amplifiers at the output and the connection of  $R_L$  means that the total resistance at the output is

$$10 \text{ k}\Omega \parallel 10 \text{ k}\Omega \parallel 10 \text{ k}\Omega = \frac{10}{3} \text{ k}\Omega. \text{ Thus the component of } v_o \text{ due to } v_2 \text{ will be}$$

$$\begin{aligned} v_{o2} &= v_2 \frac{10}{10 + 10} \times G_{m2} \times \frac{10}{3} \\ &= v_2 \times 0.5 \times 20 \times \frac{10}{3} = 33.3 v_2 \end{aligned}$$

To reduce the gain seen by  $v_2$  from 33.3 to 20, we connect a resistance  $R_p$  in parallel with  $R_L$ ,

$$\begin{aligned} \left( \frac{10}{3} \parallel R_p \right) &= 2 \text{ k}\Omega \\ \Rightarrow R_p &= 5 \text{ k}\Omega \end{aligned}$$

We next consider the path for  $v_1$ . Since  $v_1$  must see a gain factor of only 10, which is half that seen by  $v_2$ , we have to reduce the fraction of  $v_1$  that appears at the input of its transconductance amplifier to half that that appears at the input of the  $v_2$  transconductance amplifier. We just saw that  $0.5 v_2$  appears at the input of the  $v_2$  transconductance amplifier. Thus, for the  $v_1$  transconductance amplifier, we want  $0.25 v_1$  to appear at the input. This can be achieved by shunting the input of the  $v_1$  transconductance

This figure belongs to Problem 1.61.

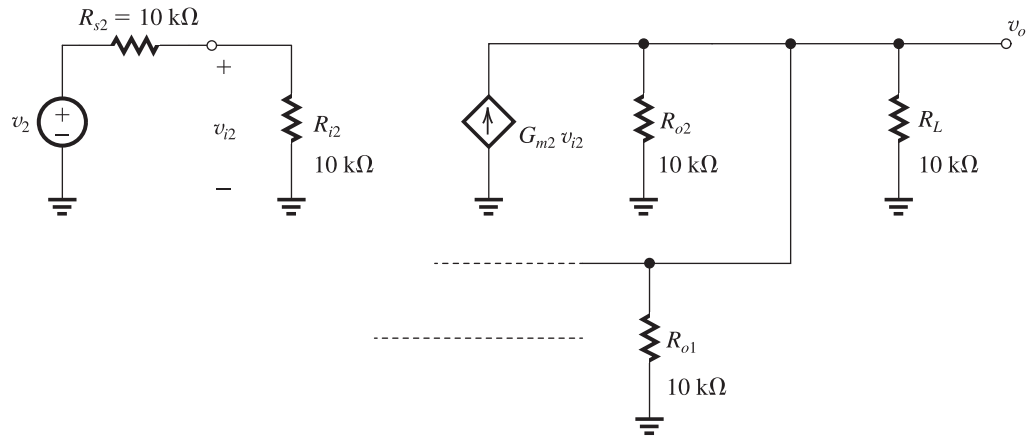

amplifier by a resistance  $R_{p1}$  as in the following figure.

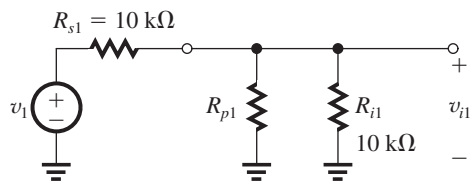

The value of  $R_{p1}$  can be found from

$$\frac{(R_{p1} \parallel R_{i1})}{(R_{p1} \parallel R_{i1}) + R_{s1}} = 0.25$$

Thus,

$$1 + \frac{R_{s1}}{(R_{p1} \parallel R_{i1})} = 4$$

$$\Rightarrow R_{p1} \parallel R_{i1} = \frac{R_{s1}}{3} = \frac{10}{3}$$

$$R_{p1} \parallel 10 = \frac{10}{3}$$

$$\Rightarrow R_{p1} = 5\text{ k}\Omega$$

The final circuit will be as follows:

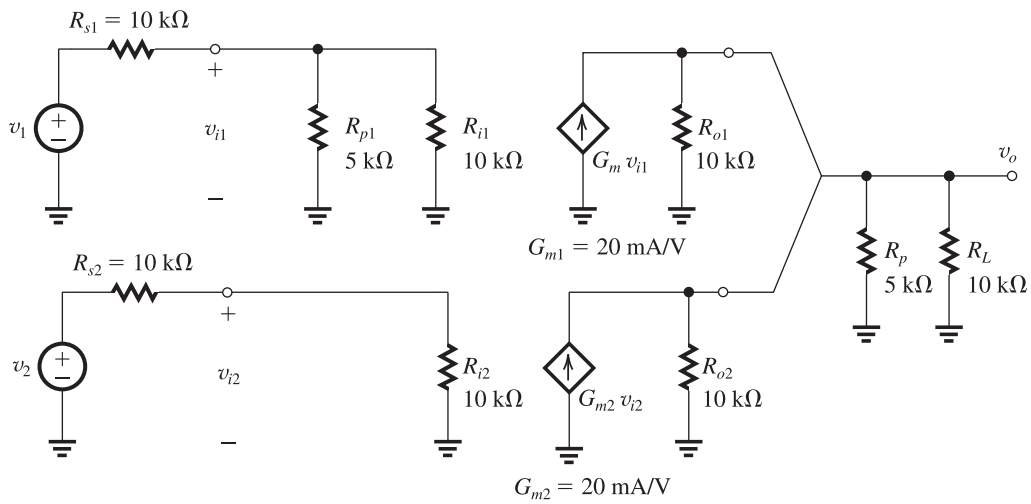

1.62 (a)

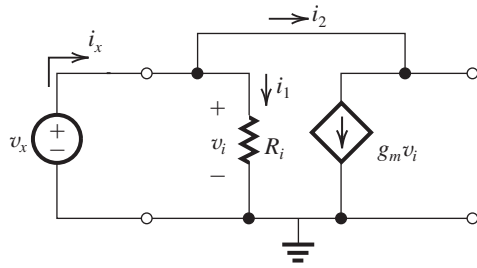

$$\left. \begin{aligned} i_x &= i_1 + i_2 \\ i_1 &= v_i / R_i \\ i_2 &= g_m v_i \\ v_i &= v_x \end{aligned} \right\} \begin{aligned} i_x &= v_x / R_i + g_m v_x \\ i_x &= v_x \left( \frac{1}{R_i} + g_m \right) \\ \frac{v_x}{i_x} &= \frac{1}{1/R_i + g_m} \\ &= \frac{R_i}{1 + g_m R_i} = R_{in} \end{aligned}$$

(b)

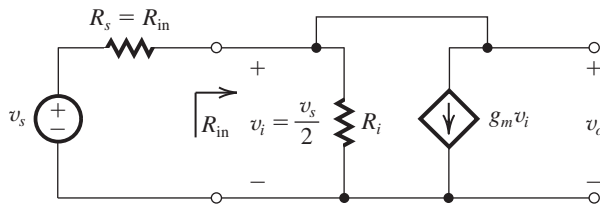

When driven by a source with source resistance  $R_{in}$  as shown in the figure above,

$$v_i = \frac{R_{in}}{R_s + R_{in}} \times v_s = \frac{R_{in}}{R_{in} + R_{in}} \times v_s = 0.5 \times v_s$$

Thus,

$$\frac{v_o}{v_s} = 0.5 \frac{v_o}{v_i}$$

1.63 Voltage amplifier:

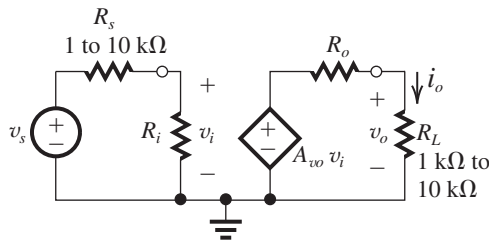

For  $R_s$  varying in the range 1 kΩ to 10 kΩ and  $\Delta v_o$  limited to 10%, select  $R_i$  to be sufficiently large:

$$R_i \geq 10 R_{smax}$$

$$R_i = 10 \times 10 \text{ k}\Omega = 100 \text{ k}\Omega = 1 \times 10^5 \Omega$$

For  $R_L$  varying in the range 1 kΩ to 10 kΩ, the load voltage variation limited to 10%, select  $R_o$  sufficiently low:

$$R_o \leq \frac{R_{Lmin}}{10}$$

$$R_o = \frac{1 \text{ k}\Omega}{10} = 100 \Omega = 1 \times 10^2 \Omega$$

Now find  $A_{vo}$ :

$$v_{omin} = 10 \text{ mV} \times \frac{R_i}{R_i + R_{smax}} \times A_{vo} \frac{R_{Lmin}}{R_o + R_{Lmin}}$$

$$1 = 10 \times 10^{-3} \times \frac{100 \text{ k}\Omega}{100 \text{ k}\Omega + 10 \text{ k}\Omega}$$

$$\times A_{vo} \times \frac{1 \text{ k}\Omega}{100 \Omega + 1 \text{ k}\Omega}$$

$$\Rightarrow A_{vo} = 121 \text{ V/V}$$

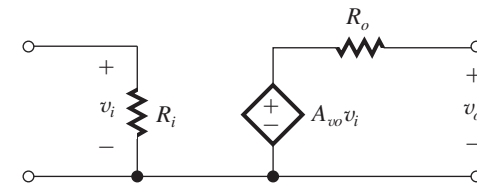

Values for the voltage amplifier equivalent circuit are

$$R_i = 1 \times 10^5 \Omega, A_{vo} = 121 \text{ V/V}, \text{ and}$$

$$R_o = 1 \times 10^2 \Omega$$

1.64 Transresistance amplifier:

To limit  $\Delta v_o$  to 10% corresponding to  $R_s$  varying in the range 1 kΩ to 10 kΩ, we select  $R_i$  sufficiently low;

$$R_i \leq \frac{R_{smin}}{10}$$

$$\text{Thus, } R_i = 100 \Omega = 1 \times 10^2 \Omega$$

To limit  $\Delta v_o$  to 10% while  $R_L$  varies over the range 1 kΩ to 10 kΩ, we select  $R_o$  sufficiently low;

$$R_o \leq \frac{R_{Lmin}}{10}$$

$$\text{Thus, } R_o = 100 \Omega = 1 \times 10^2 \Omega$$

Now, for  $i_s = 10 \mu\text{A}$ ,

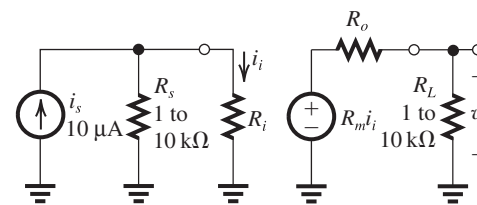

$$v_{o\min} = 10^{-5} \frac{R_{s\min}}{R_{s\min} + R_i} R_m \frac{R_{L\min}}{R_{L\min} + R_o}$$

$$1 = 10^{-5} \frac{1000}{1000 + 100} R_m \frac{1000}{1000 + 100}$$

$$\Rightarrow R_m = 1.21 \times 10^5 \Omega$$

$$= 121 \text{ k}\Omega$$

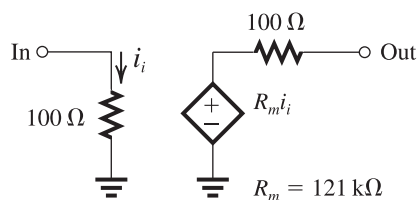

1.65

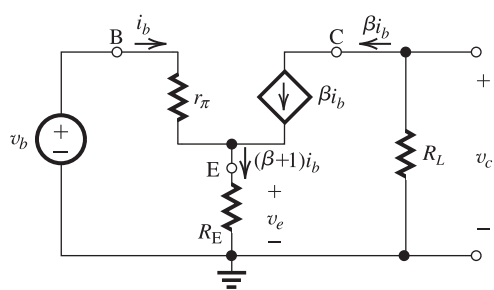

The node equation at  $E$  yields the current through  $R_E$  as  $(\beta i_b + i_b) = (\beta + 1)i_b$ . The voltage  $v_c$  can be found in terms of  $i_b$  as

$$v_c = -\beta i_b R_L \quad (1)$$

The voltage  $v_b$  can be related to  $i_b$  by writing for the input loop:

$$v_b = i_b r_\pi + (\beta + 1)i_b R_E$$

Thus,

$$v_b = r_\pi + (\beta + 1)R_E i_b \quad (2)$$

Dividing Eq. (1) by Eq. (2) yields

$$\frac{v_c}{v_b} = -\frac{\beta R_L}{r_\pi + (\beta + 1)R_E} \quad \text{Q.E.D}$$

The voltage  $v_e$  is related to  $i_b$  by

$$v_e = (\beta + 1)i_b R_E$$

That is,

$$v_e = (\beta + 1)R_E i_b \quad (3)$$

Dividing Eq. (3) by Eq. (2) yields

$$\frac{v_e}{v_b} = \frac{(\beta + 1)R_E}{(\beta + 1)R_E + r_\pi}$$

Dividing the numerator and denominator by  $(\beta + 1)$  gives

$$\frac{v_e}{v_b} = \frac{R_E}{R_E + r_\pi/(\beta + 1)} \quad \text{Q.E.D}$$

1.66

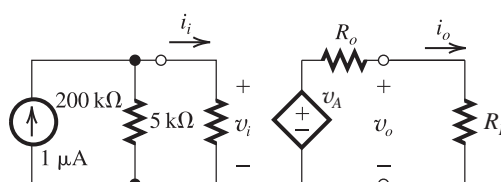

When  $R_L = 0$ ,

$$i_o = i_{sc} = 5 \text{ mA} = \frac{v_A}{R_o}$$

$$\Rightarrow v_A - 5R_o = 0 \quad (1)$$

When  $R_L = 2 \text{ k}\Omega$ ,

$$v_o = 5 \text{ V} = v_A \frac{2}{R_o + 2}$$

$$\Rightarrow 2v_A - 5R_o = 10 \quad (2)$$

Subtracting Eqs. (2) - (1),

$$v_A = 10 \text{ V}$$

Substituting into Eq. (1)

$$R_o = \frac{10}{5} = 2 \text{ k}\Omega$$

When  $R_L = 1 \text{ k}\Omega$ ,

$$A_v = \frac{v_o}{v_i} = \frac{10 \times \frac{1}{2+1}}{0.001 \times 200 \parallel 5}$$

$$= 683.3 \text{ V/V} = 56.7 \text{ dB}$$

The overall current gain is,

$$A_i = \frac{i_o}{i_s} = \frac{2+1}{0.001}$$

$$= 3333.3 \text{ A/A} = 70.5 \text{ dB}$$

The power gain of the amplifier is,

$$A_p = \frac{v_o^2/R_L}{v_i^2/R_i} = \frac{3.33^2/1}{0.00487^2/5}$$

$$= 2.34 \times 10^6 \text{ W/W} = 127.4 \text{ dB}$$

1.67

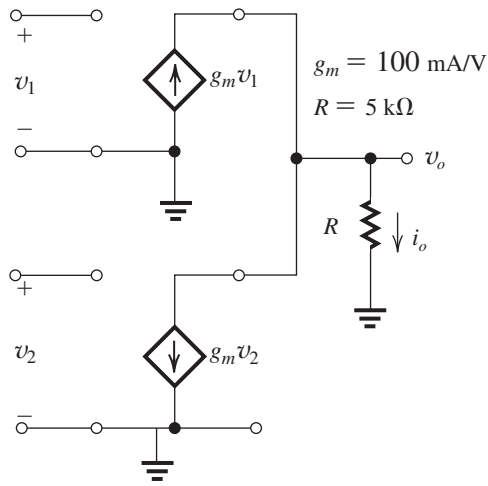

$$i_o = g_m v_1 - g_m v_2$$

$$v_o = i_o R_L = g_m R (v_1 - v_2)$$

$$v_1 = v_2 = 1 \text{ V} \quad \therefore v_o = 0 \text{ V}$$

$$\left. \begin{array}{l} v_1 = 1.01 \text{ V} \\ v_2 = 0.99 \text{ V} \end{array} \right\} \quad \therefore v_o = 100 \times 5 \times 0.02 = 10 \text{ V}$$

1.68

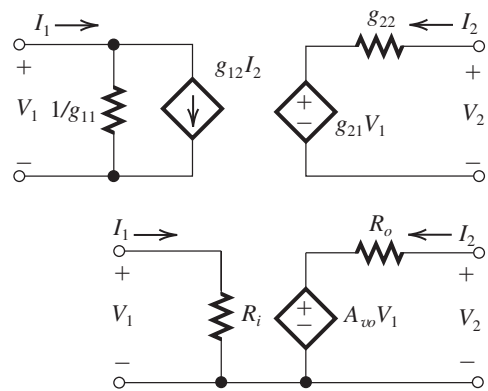

The correspondences between the current and voltage variables are indicated by comparing the two equivalent-circuit models above. At the outset we observe that at the input side of the  $g$ -parameter model, we have the controlled current source  $g_{12}I_2$ . This has no correspondence in the equivalent-circuit model of Fig. 1.16(a). It represents internal feedback, internal to the

amplifier circuit. In developing the model of Fig. 1.16(a), we assumed that the amplifier is unilateral (i.e., has no internal feedback, or that the input side does not know what happens at the output side). If we neglect this internal feedback, that is, assume  $g_{12} = 0$ , we can compare the two models and thus obtain:

$$R_i = 1/g_{11}$$

$$A_{vo} = g_{21}$$

$$R_o = g_{22}$$

1.69 Circuits of Fig. 1.22:

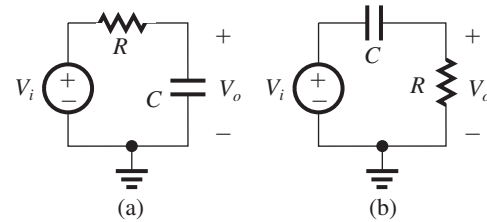

For (a)  $V_o = V_i \left( \frac{1/sC}{1/sC + R} \right)$

$$\frac{V_o}{V_i} = \frac{1}{1 + sCR}$$

which is of the form shown for the low-pass function in Table 1.2 with  $K = 1$  and  $\omega_0 = 1/RC$ .

For (b)  $V_o = V_i \left( \frac{R}{R + \frac{1}{sC}} \right)$

$$\frac{V_o}{V_i} = \frac{sRC}{1 + sCR}$$

$$\frac{V_o}{V_i} = \frac{s}{s + \frac{1}{RC}}$$

which is of the form shown in Table 1.2 for the high-pass function, with  $K = 1$  and  $\omega_0 = 1/RC$ .

1.70

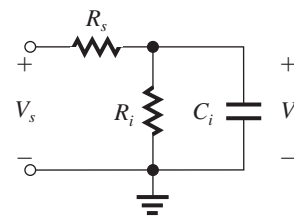

$$\begin{aligned} \frac{V_i}{V_s} &= \frac{\frac{R_i \frac{1}{sC_i}}{R_i + \frac{1}{sC_i}}}{R_s + \left( \frac{R_i \frac{1}{sC_i}}{R_i + \frac{1}{sC_i}} \right)} \\ &= \frac{\frac{R_i}{1 + sC_i R_i}}{R_s + \left( \frac{R_i}{1 + sC_i R_i} \right)} \\ &= \frac{R_i}{R_s + sC_i R_i R_s + R_i} \\ \frac{V_i}{V_s} &= \frac{R_i}{(R_s + R_i) + sC_i R_i R_s} = \\ &= \frac{\frac{R_i}{(R_s + R_i)}}{1 + s \left( \frac{C_i R_i R_s}{R_s + R_i} \right)} \end{aligned}$$

which is a low-pass STC function with  $K = \frac{R_i}{R_s + R_i}$  and  $\omega_0 = 1/C_i(R_i \parallel R_s)$ .

For  $R_s = 10 \text{ k}\Omega$ ,  $R_i = 40 \text{ k}\Omega$ , and  $C_i = 5 \text{ pF}$ ,

$$\omega_0 = \frac{1}{5 \times 10^{-12} \times (40 \parallel 10) \times 10^3} = 25 \text{ Mrad/s}$$

$$f_0 = \frac{25}{2\pi} = 4 \text{ MHz}$$

The dc gain is

$$K = \frac{40}{10 + 40} = 0.8 \text{ V/V}$$

**1.71** Using the voltage-divider rule.

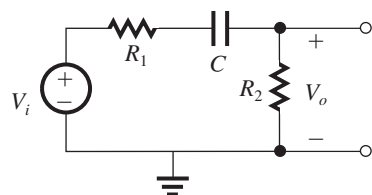

$$T(s) = \frac{V_o}{V_i} = \frac{R_2}{R_2 + R_1 + \frac{1}{sC}}$$

$$T(s) = \left( \frac{R_2}{R_1 + R_2} \right) \left( \frac{s}{s + \frac{1}{C(R_1 + R_2)}} \right)$$

which from Table 1.2 is of the high-pass type with

$$K = \frac{R_2}{R_1 + R_2} \quad \omega_0 = \frac{1}{C(R_1 + R_2)}$$

As a further verification that this is a high-pass network and  $T(s)$  is a high-pass transfer function, see that as  $s \Rightarrow 0$ ,  $T(s) \Rightarrow 0$ ; and as  $s \Rightarrow \infty$ ,

$T(s) = R_2/(R_1 + R_2)$ . Also, from the circuit, observe as  $s \rightarrow \infty$ ,  $(1/sC) \rightarrow 0$  and  $V_o/V_i = R_2/(R_1 + R_2)$ . Now, for  $R_1 = 20 \text{ k}\Omega$ ,  $R_2 = 100 \text{ k}\Omega$  and  $C = 0.1 \mu\text{F}$ ,

$$f_0 = \frac{\omega_0}{2\pi} = \frac{1}{2\pi \times 0.1 \times 10^{-6} (20 + 100) \times 10^3} = 13.26 \text{ Hz}$$

$$|T(j\omega_0)| = \frac{K}{\sqrt{2}} = \frac{100}{20 + 100} \frac{1}{\sqrt{2}} = 0.59 \text{ V/V}$$

**1.72** Using the voltage divider rule,

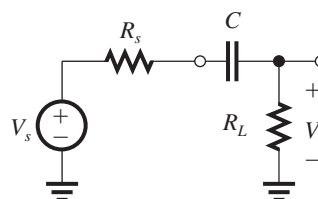

$$\begin{aligned} \frac{V_i}{V_s} &= \frac{R_L}{R_L + R_s + \frac{1}{sC}} \\ &= \frac{R_L}{R_L + R_s} \frac{s}{s + \frac{1}{C(R_L + R_s)}} \end{aligned}$$

which is of the high-pass STC type (see Table 1.2) with

$$K = \frac{R_L}{R_L + R_s} \quad \omega_0 = \frac{1}{C(R_L + R_s)}$$

For  $f_0 \leq 200 \text{ Hz}$

$$\frac{1}{2\pi C(R_L + R_s)} \leq 200$$

$$\Rightarrow C \geq \frac{1}{2\pi \times 200(10 + 4) \times 10^3}$$

Thus, the smallest value of  $C$  that will do the job is  $C = 0.057 \mu\text{F}$  or  $57 \text{ nF}$ .

**1.73** The given measured data indicate that this amplifier has a low-pass STC frequency response with a low-frequency gain of 60 dB, and a 3-dB frequency of 1000 Hz. From our knowledge of the Bode plots for low-pass STC networks [Fig. 1.23(a)], we can complete the table entries and sketch the amplifier frequency response.

$f$ (Hz)	$ T $ (dB)	$\angle T$ ( $^\circ$ )
0	60	0
100	60	0
1000	57	$-45^\circ$
$10^4$	40	$-90^\circ$
$10^5$	20	$-90^\circ$
$10^6$	0	$-90^\circ$

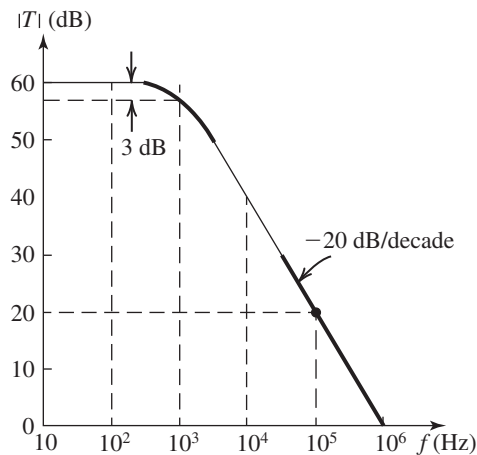

**1.74** From our knowledge of the Bode plots of STC low-pass and high-pass networks, we see that this amplifier has a midband gain of 80 dB, a low-frequency response of the high-pass STC type with  $f_{3dB} = 10^2$  Hz, and a high-frequency response of the low-pass STC type with  $f_{3dB} = 10^5$  Hz. We thus can sketch the amplifier frequency response and complete the table entries as follows.

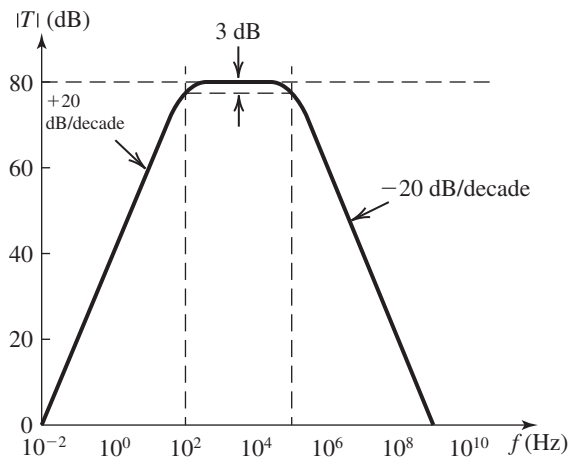

$f(\text{Hz})$	$10^{-2}$	1	$10^2$	$10^3$	$10^4$	$10^5$	$10^6$	$10^7$	$10^9$
$ T (\text{dB})$	0	40	77	80	80	77	60	40	0

**1.75** Since the overall transfer function is that of three identical STC LP circuits in cascade (but with no loading effects, since the buffer amplifiers have infinite input and zero output resistances) the overall gain will drop by 3 dB below the value at dc at the frequency for which the gain of each STC circuit is 1 dB down. This frequency is found as follows: The transfer function of each STC circuit is

$$T(s) = \frac{1}{1 + \frac{s}{\omega_0}}$$

where

$$\omega_0 = 1/CR$$

Thus,

$$|T(j\omega)| = \frac{1}{\sqrt{1 + \left(\frac{\omega}{\omega_0}\right)^2}}$$

$$20 \log \frac{1}{\sqrt{1 + \left(\frac{\omega_{1 \text{ dB}}}{\omega_0}\right)^2}} = -1$$

$$\Rightarrow 1 + \left(\frac{\omega_{1 \text{ dB}}}{\omega_0}\right)^2 = 10^{0.1}$$

$$\omega_{1 \text{ dB}} = 0.51\omega_0$$

$$\omega_{1 \text{ dB}} = 0.51/CR$$

**1.76**  $R_s = 100 \text{ k}\Omega$ , since the 3-dB frequency is reduced by a very high factor (from 5 MHz to 100 kHz)  $C_2$  must be much larger than  $C_1$ . Thus, neglecting  $C_1$  we find  $C_2$  from

$$100 \text{ kHz} \simeq \frac{1}{2\pi C_2 R_s}$$

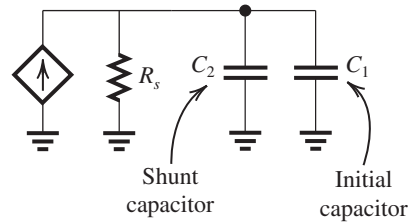

$$= \frac{1}{2\pi C_2 \times 10^5}$$

$$\Rightarrow C_2 = 15.9 \text{ pF}$$

If the original 3-dB frequency (5 MHz) is attributable to  $C_1$ , then

$$5 \text{ MHz} = \frac{1}{2\pi C_1 R_s}$$

$$\Rightarrow C_1 = \frac{1}{2\pi \times 5 \times 10^6 \times 10^5}$$

$$= 0.32 \text{ pF}$$

**1.77** Since when  $C$  is connected to node A the 3-dB frequency is reduced by a large factor, the value of  $C$  must be much larger than whatever parasitic capacitance originally existed at node A (i.e., between A and ground). Furthermore, it must be that  $C$  is now the dominant determinant of the amplifier 3-dB frequency (i.e., it is dominating over whatever may be happening at

node B or anywhere else in the amplifier). Thus, we can write

$$200 \text{ kHz} = \frac{1}{2\pi C(R_{o1} \parallel R_{i2})}$$

$$\Rightarrow (R_{o1} \parallel R_{i2}) = \frac{1}{2\pi \times 200 \times 10^3 \times 1 \times 10^{-9}}$$

$$= 0.8 \text{ k}\Omega$$

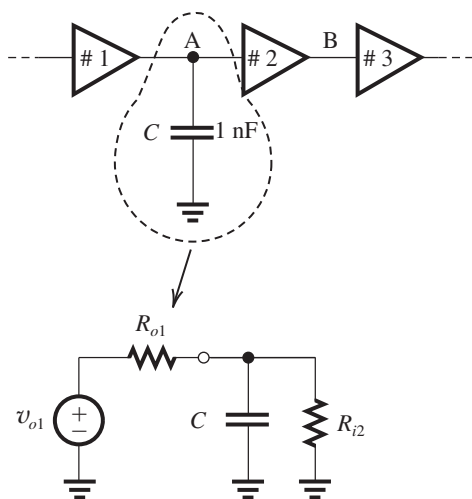

Now  $R_{i2} = 100 \text{ k}\Omega$ .

Thus  $R_{o1} \simeq 0.8 \text{ k}\Omega$

Similarly, for node B,

$$40 \text{ kHz} = \frac{1}{2\pi C(R_{o2} \parallel R_{i3})}$$

$$\Rightarrow R_{o2} \parallel R_{i3} = \frac{1}{2\pi \times 40 \times 10^3 \times 1 \times 10^{-9}}$$

$$= 3.98 \text{ k}\Omega$$

$$R_{o2} = 4.14 \text{ k}\Omega$$

The designer should connect a capacitor of value  $C_p$  to node B where  $C_p$  can be found from

$$5 \text{ kHz} = \frac{1}{2\pi C_p(R_{o2} \parallel R_{i3})}$$

$$\Rightarrow C_p = \frac{1}{2\pi \times 5 \times 10^3 \times 3.98 \times 10^3}$$

$$= 8 \text{ nF}$$

Note that if she chooses to use node A, she would need to connect a capacitor 5 times larger!

**1.78** For the input circuit, the corner frequency  $f_{01}$  is found from

$$f_{01} = \frac{1}{2\pi C_1(R_s + R_i)}$$

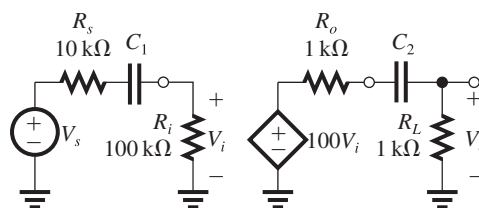

For  $f_{01} \leq 100 \text{ Hz}$ ,

$$\frac{1}{2\pi C_1(10 + 100) \times 10^3} \leq 100$$

$$\Rightarrow C_1 \geq \frac{1}{2\pi \times 110 \times 10^3 \times 10^2} = 1.4 \times 10^{-8} \text{ F}$$

Thus we select  $C_1 = 1 \times 10^{-7} \text{ F} = 0.1 \mu\text{F}$ . The actual corner frequency resulting from  $C_1$  will be

$$f_{01} = \frac{1}{2\pi \times 10^{-7} \times 110 \times 10^3} = 14.5 \text{ Hz}$$

For the output circuit,

$$f_{02} = \frac{1}{2\pi C_2(R_o + R_L)}$$

For  $f_{02} \leq 100 \text{ Hz}$ ,

$$\frac{1}{2\pi C_2(1 + 1) \times 10^3} \leq 100$$

$$\Rightarrow C_2 \geq \frac{1}{2\pi \times 2 \times 10^3 \times 10^2} = 0.8 \times 10^{-6}$$

Select  $C_2 = 1 \times 10^{-6} = 1 \mu\text{F}$ .

This will place the corner frequency at

$$f_{02} = \frac{1}{2\pi \times 10^{-6} \times 2 \times 10^3} = 80 \text{ Hz}$$

$$T(s) = 100 \frac{s}{\left(1 + \frac{s}{2\pi f_{01}}\right) \left(1 + \frac{s}{2\pi f_{02}}\right)}$$

**1.79** The LP factor  $1/(1 + jf/10^5)$  results in a Bode plot like that in Fig. 1.23(a) with the 3-dB frequency  $f_0 = 10^5 \text{ Hz}$ . The high-pass factor  $1/(1 + 10^2/jf)$  results in a Bode plot like that in Fig. 1.24(a) with the 3-dB frequency

$$f_0 = 10^2 \text{ Hz}.$$

The Bode plot for the overall transfer function can be obtained by summing the dB values of the two individual plots and then shifting the

resulting plot vertically by 60 dB (corresponding to the factor 1000 in the numerator). The result is as follows:

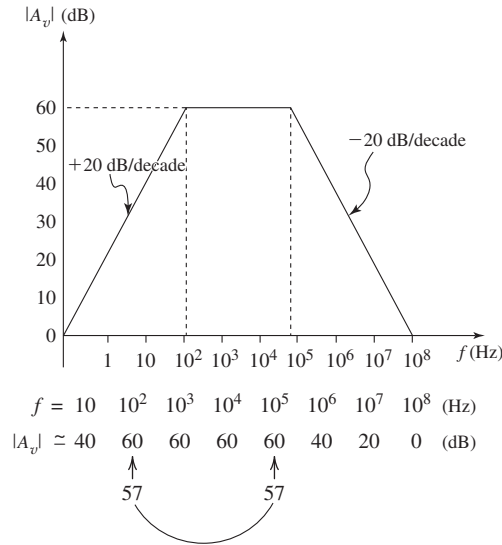

$$\text{Bandwidth} = 10^5 - 10^2 = 99,900 \text{ Hz}$$

**1.80**

$$T_i(s) = \frac{V_i(s)}{V_s(s)} = \frac{1/sC_1}{1/sC_1 + R_1} = \frac{1}{sC_1R_1 + 1}$$

LP with a 3-dB frequency

$$f_{0i} = \frac{1}{2\pi C_1 R_1} = \frac{1}{2\pi \cdot 10^{-11} \cdot 10^5} = 159 \text{ kHz}$$

For  $T_o(s)$ , the following equivalent circuit can be used:

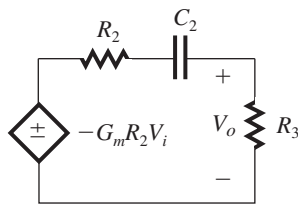

$$T_o(s) = \frac{V_o}{V_i} = -G_m R_2 \frac{R_3}{R_2 + R_3 + 1/sC_2}$$

$$= -G_m (R_2 \parallel R_3) \frac{s}{s + \frac{1}{C_2(R_2 + R_3)}}$$

which is an HP, with

$$\text{3-dB frequency} = \frac{1}{2\pi C_2 (R_2 + R_3)}$$

$$= \frac{1}{2\pi \cdot 100 \times 10^{-9} \times 110 \times 10^3} = 14.5 \text{ Hz}$$

$$\therefore T(s) = T_i(s)T_o(s)$$

$$= \frac{1}{1 + \frac{s}{2\pi \times 159 \times 10^3}} \times -909.1 \times \frac{s}{s + (2\pi \times 14.5)}$$

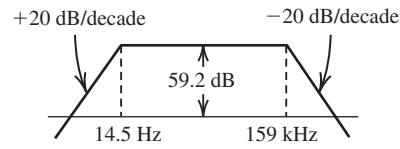

$$\text{Bandwidth} = 159 \text{ kHz} - 14.5 \text{ Hz} \approx 159 \text{ kHz}$$

**1.81**  $V_i = V_s \frac{R_i}{R_s + R_i}$  (1)

(a) To satisfy constraint (1), namely,

$$V_i \geq \left(1 - \frac{x}{100}\right) V_s$$

we substitute in Eq. (1) to obtain

$$\frac{R_i}{R_s + R_i} \geq 1 - \frac{x}{100} \quad (2)$$

Thus

$$\frac{R_s + R_i}{R_i} \leq \frac{1}{1 - \frac{x}{100}}$$

$$\frac{R_s}{R_i} \leq \frac{1}{1 - \frac{x}{100}} - 1 = \frac{\frac{x}{100}}{1 - \frac{x}{100}}$$

which can be expressed as

$$\frac{R_i}{R_s} \geq \frac{1 - \frac{x}{100}}{\frac{x}{100}}$$

resulting in

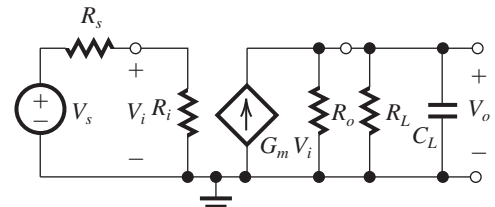

$$R_i \geq R_s \left( \frac{100}{x} - 1 \right) \quad (3)$$

(b) The 3-dB frequency is determined by the parallel RC circuit at the output

$$f_0 = \frac{1}{2\pi} \omega_0 = \frac{1}{2\pi} \frac{1}{C_L (R_L \parallel R_o)}$$

Thus,

$$f_0 = \frac{1}{2\pi C_L} \left( \frac{1}{R_L} + \frac{1}{R_o} \right)$$

To obtain a value for  $f_0$  greater than a specified value  $f_{3\text{dB}}$  we select  $R_o$  so that

$$\begin{aligned} \frac{1}{2\pi C_L} \left( \frac{1}{R_L} + \frac{1}{R_o} \right) &\geq f_{3\text{dB}} \\ \frac{1}{R_L} + \frac{1}{R_o} &\geq 2\pi C_L f_{3\text{dB}} \\ \frac{1}{R_o} &\geq 2\pi C_L f_{3\text{dB}} - \frac{1}{R_L} \\ R_o &\leq \frac{1}{2\pi f_{3\text{dB}} C_L - \frac{1}{R_L}} \end{aligned} \quad (4)$$

(c) To satisfy constraint (c), we first determine the dc gain as

$$\text{dc gain} = \frac{R_i}{R_s + R_i} G_m (R_o \parallel R_L)$$

For the dc gain to be greater than a specified value  $A_0$ ,

$$\frac{R_i}{R_s + R_i} G_m (R_o \parallel R_L) \geq A_0$$

The first factor on the left-hand side is (from constraint (2)) greater or equal to  $(1 - x/100)$ . Thus

$$G_m \geq \frac{A_0}{\left(1 - \frac{x}{100}\right) (R_o \parallel R_L)} \quad (5)$$

Substituting  $R_s = 10 \text{ k}\Omega$  and  $x = 10\%$  in (3) results in

$$R_i \geq 10 \left( \frac{100}{100} - 1 \right) = 90 \text{ k}\Omega$$

Substituting  $f_{3\text{dB}} = 2 \text{ MHz}$ ,  $C_L = 20 \text{ pF}$ , and

$R_L = 10 \text{ k}\Omega$  in Eq. (4) results in

$$\begin{aligned} R_o &\leq \frac{1}{2\pi \times 2 \times 10^6 \times 20 \times 10^{-12} - \frac{1}{10^4}} \\ &= 6.61 \text{ k}\Omega \end{aligned}$$

Substituting  $A_0 = 100$ ,  $x = 10\%$ ,  $R_L = 10 \text{ k}\Omega$ , and  $R_o = 6.61 \text{ k}\Omega$ , Eq. (5) results in

$$G_m \geq \frac{100}{\left(1 - \frac{10}{100}\right) (10 \parallel 6.61) \times 10^3} = 27.9 \text{ mA/V}$$

**1.82** Using the voltage divider rule, we obtain

$$\frac{V_o}{V_i} = \frac{Z_2}{Z_1 + Z_2}$$

where

$$Z_1 = R_1 \parallel \frac{1}{sC_1} \text{ and } Z_2 = R_2 \parallel \frac{1}{sC_2}$$

It is obviously more convenient to work in terms of admittances. Therefore we express  $V_o/V_i$  in the alternate form

$$\frac{V_o}{V_i} = \frac{Y_1}{Y_1 + Y_2}$$

and substitute  $Y_1 = (1/R_1) + sC_1$  and  $Y_2 = (1/R_2) + sC_2$  to obtain

$$\begin{aligned} \frac{V_o}{V_i} &= \frac{\frac{1}{R_1} + sC_1}{\frac{1}{R_1} + \frac{1}{R_2} + s(C_1 + C_2)} \\ &= \frac{C_1}{C_1 + C_2} \frac{s + \frac{1}{C_1 R_1}}{s + \frac{1}{(C_1 + C_2) \left( \frac{1}{R_1} + \frac{1}{R_2} \right)}} \end{aligned}$$

This transfer function will be independent of frequency ( $s$ ) if the second factor reduces to unity.

This in turn will happen if

$$\frac{1}{C_1 R_1} = \frac{1}{C_1 + C_2} \left( \frac{1}{R_1} + \frac{1}{R_2} \right)$$

which can be simplified as follows:

$$\frac{C_1 + C_2}{C_1} = R_1 \left( \frac{1}{R_1} + \frac{1}{R_2} \right) \quad (1)$$

$$1 + \frac{C_2}{C_1} = 1 + \frac{R_1}{R_2}$$

or

$$C_1 R_1 = C_2 R_2 \Rightarrow C_1 = C_2 (R_2 / R_1)$$

When this condition applies, the attenuator is said to be compensated, and its transfer function is given by

$$\frac{V_o}{V_i} = \frac{C_1}{C_1 + C_2}$$

which, using Eq. (1), can be expressed in the alternate form

$$\frac{V_o}{V_i} = \frac{1}{1 + \frac{R_1}{R_2}} = \frac{R_2}{R_1 + R_2}$$

Thus when the attenuator is compensated ( $C_1 R_1 = C_2 R_2$ ), its transmission can be determined either by its two resistors  $R_1$ ,  $R_2$  or by its two capacitors.  $C_1$ ,  $C_2$ , and the transmission is *not* a function of frequency.

**1.83** The HP STC circuit whose response determines the frequency response of the amplifier in the low-frequency range has a phase angle of  $5.7^\circ$  at  $f = 100$  Hz. Using the equation for  $\angle T(j\omega)$  from Table 1.2, we obtain

$$\tan^{-1} \frac{f_0}{100} = 5.7^\circ \Rightarrow f_0 = 10 \text{ Hz} \Rightarrow \tau = \frac{1}{2\pi \cdot 10} =$$

15.9 ms

The LP STC circuit whose response determines the amplifier response at the high-frequency end has a phase angle of  $-5.7^\circ$  at  $f = 1$  kHz. Using the relationship for  $\angle T(j\omega)$  given in Table 1.2, we obtain for the LP STC circuit.

$$-\tan^{-1} \frac{10^3}{f_0} = -5.7^\circ \Rightarrow f_0 \simeq 10 \text{ kHz} \Rightarrow \tau =$$

$$\frac{1}{2\pi \cdot 10^4} = 15.9 \mu\text{s}$$

At  $f = 100$  Hz, the drop in gain is due to the HP STC network, and thus its value is

$$20 \log \frac{1}{\sqrt{1 + \left(\frac{10}{100}\right)^2}} = -0.04 \text{ dB}$$

Similarly, at the drop in gain  $f = 1$  kHz is caused by the LP STC network. The drop in gain is

$$20 \log \frac{1}{\sqrt{1 + \left(\frac{1000}{10,000}\right)^2}} = -0.04 \text{ dB}$$

The gain drops by 3 dB at the corner frequencies of the two STC networks, that is, at  $f = 10$  Hz and  $f = 10$  kHz.

**Chapter 1**

**Solutions to Exercises within the Chapter**

**Ex: 1.1** When output terminals are open-circuited, as in Fig. 1.1a:

For circuit a.  $v_{oc} = v_s(t)$

For circuit b.  $v_{oc} = i_s(t) \times R_s$

When output terminals are short-circuited, as in Fig. 1.1b:

For circuit a.  $i_{sc} = \frac{v_s(t)}{R_s}$

For circuit b.  $i_{sc} = i_s(t)$

For equivalency

$$R_s i_s(t) = v_s(t)$$

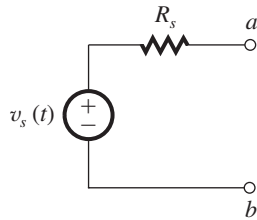

Figure 1.1a

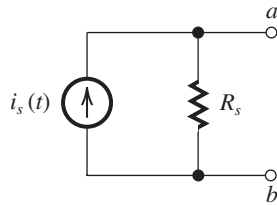
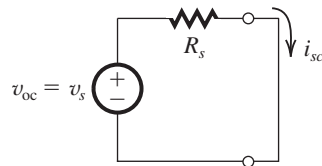

Figure 1.1b

**Ex: 1.2**



$$v_{oc} = 10 \text{ mV}$$

$$i_{sc} = 10 \text{ } \mu\text{A}$$

$$R_s = \frac{v_{oc}}{i_{sc}} = \frac{10 \text{ mV}}{10 \text{ } \mu\text{A}} = 1 \text{ k}\Omega$$

**Ex: 1.3** Using voltage divider:

$$v_o(t) = v_s(t) \times \frac{R_L}{R_s + R_L}$$

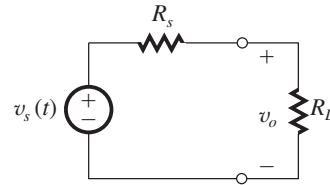

Given  $v_s(t) = 10 \text{ mV}$  and  $R_s = 1 \text{ k}\Omega$ .

If  $R_L = 100 \text{ k}\Omega$

$$v_o = 10 \text{ mV} \times \frac{100}{100 + 1} = 9.9 \text{ mV}$$

If  $R_L = 10 \text{ k}\Omega$

$$v_o = 10 \text{ mV} \times \frac{10}{10 + 1} \simeq 9.1 \text{ mV}$$

If  $R_L = 1 \text{ k}\Omega$

$$v_o = 10 \text{ mV} \times \frac{1}{1 + 1} = 5 \text{ mV}$$

If  $R_L = 100 \text{ } \Omega$

$$v_o = 10 \text{ mV} \times \frac{100}{100 + 1 \text{ K}} \simeq 0.91 \text{ mV}$$

For  $v_o = 0.8v_s$ ,

$$\frac{R_L}{R_L + R_s} = 0.8$$

Since  $R_s = 1 \text{ k}\Omega$ ,

$$R_L = 4 \text{ k}\Omega$$

**Ex: 1.4** Using current divider:

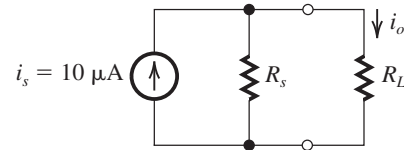

$$i_o = i_s \times \frac{R_s}{R_s + R_L}$$

Given  $i_s = 10 \text{ } \mu\text{A}$ ,  $R_s = 100 \text{ k}\Omega$ .

For

$$R_L = 1 \text{ k}\Omega, i_o = 10 \text{ } \mu\text{A} \times \frac{100}{100 + 1} = 9.9 \text{ } \mu\text{A}$$

For

$$R_L = 10 \text{ k}\Omega, i_o = 10 \text{ } \mu\text{A} \times \frac{100}{100 + 10} \simeq 9.1 \text{ } \mu\text{A}$$

For

$$R_L = 100 \text{ k}\Omega, i_o = 10 \text{ } \mu\text{A} \times \frac{100}{100 + 100} = 5 \text{ } \mu\text{A}$$

For

$$R_L = 1 \text{ M}\Omega, i_o = 10 \text{ } \mu\text{A} \times \frac{100 \text{ K}}{100 \text{ K} + 1 \text{ M}} \simeq 0.9 \text{ } \mu\text{A}$$

$$\text{For } i_o = 0.8i_s, \frac{100}{100 + R_L} = 0.8$$

$$\Rightarrow R_L = 25 \text{ k}\Omega$$

Exercise 1-2

**Ex: 1.5**  $f = \frac{1}{T} = \frac{1}{10^{-3}} = 1000 \text{ Hz}$

$\omega = 2\pi f = 2\pi \times 10^3 \text{ rad/s}$

**Ex: 1.6** (a)  $T = \frac{1}{f} = \frac{1}{60} \text{ s} = 16.7 \text{ ms}$

(b)  $T = \frac{1}{f} = \frac{1}{10^{-3}} = 1000 \text{ s}$

(c)  $T = \frac{1}{f} = \frac{1}{10^6} \text{ s} = 1 \mu\text{s}$

**Ex: 1.7** If 6 MHz is allocated for each channel, then 470 MHz to 806 MHz will accommodate

$$\frac{806 - 470}{6} = 56 \text{ channels}$$

Since the broadcast band starts with channel 14, it will go from channel 14 to channel 69.

**Ex: 1.8**  $P = \frac{1}{T} \int_0^T \frac{v^2}{R} dt$

$$= \frac{1}{T} \times \frac{V^2}{R} \times T = \frac{V^2}{R}$$

Alternatively,

$$\begin{aligned} P &= P_1 + P_3 + P_5 + \dots \\ &= \left(\frac{4V}{\sqrt{2}\pi}\right)^2 \frac{1}{R} + \left(\frac{4V}{3\sqrt{2}\pi}\right)^2 \frac{1}{R} \\ &\quad + \left(\frac{4V}{5\sqrt{2}\pi}\right)^2 \frac{1}{R} + \dots \\ &= \frac{V^2}{R} \times \frac{8}{\pi^2} \times \left(1 + \frac{1}{9} + \frac{1}{25} + \frac{1}{49} + \dots\right) \end{aligned}$$

It can be shown by direct calculation that the infinite series in the parentheses has a sum that approaches  $\pi^2/8$ ; thus  $P$  becomes  $V^2/R$  as found from direct calculation.

Fraction of energy in fundamental

$$= 8/\pi^2 = 0.81$$

Fraction of energy in first five harmonics

$$= \frac{8}{\pi^2} \left(1 + \frac{1}{9} + \frac{1}{25}\right) = 0.93$$

Fraction of energy in first seven harmonics

$$= \frac{8}{\pi^2} \left(1 + \frac{1}{9} + \frac{1}{25} + \frac{1}{49}\right) = 0.95$$

Fraction of energy in first nine harmonics

$$= \frac{8}{\pi^2} \left(1 + \frac{1}{9} + \frac{1}{25} + \frac{1}{49} + \frac{1}{81}\right) = 0.96$$

Note that 90% of the energy of the square wave is in the first three harmonics, that is, in the fundamental and the third harmonic.

**Ex: 1.9** (a)  $D$  can represent 15 equally-spaced values between 0 and 3.75 V. Thus, the values are spaced 0.25 V apart.

$v_A = 0 \text{ V} \Rightarrow D = 0000$

$v_A = 0.25 \text{ V} \Rightarrow D = 0000$

$v_A = 1 \text{ V} \Rightarrow D = 0000$

$v_A = 3.75 \text{ V} \Rightarrow D = 0000$

(b) (i) 1 level spacing:  $2^0 \times +0.25 = +0.25 \text{ V}$

(ii) 2 level spacings:  $2^1 \times +0.25 = +0.5 \text{ V}$

(iii) 4 level spacings:  $2^2 \times +0.25 = +1.0 \text{ V}$

(iv) 8 level spacings:  $2^3 \times +0.25 = +2.0 \text{ V}$

(c) The closest discrete value represented by  $D$  is +1.25 V; thus  $D = 0101$ . The error is -0.05 V, or  $-0.05/1.3 \times 100 = -4\%$ .

**Ex: 1.10** Voltage gain =  $20 \log 100 = 40 \text{ dB}$

Current gain =  $20 \log 1000 = 60 \text{ dB}$

Power gain =  $10 \log A_p = 10 \log (A_v A_i)$   
 $= 10 \log 10^5 = 50 \text{ dB}$

**Ex: 1.11**  $P_{dc} = 15 \times 8 = 120 \text{ mW}$

$$P_L = \frac{(6/\sqrt{2})^2}{1} = 18 \text{ mW}$$

$P_{dissipated} = 120 - 18 = 102 \text{ mW}$

$$\eta = \frac{P_L}{P_{dc}} \times 100 = \frac{18}{120} \times 100 = 15\%$$

**Ex: 1.12**  $v_o = 1 \times \frac{10}{10^6 + 10} \simeq 10^{-5} \text{ V} = 10 \mu\text{V}$

$$P_L = v_o^2/R_L = \frac{(10 \times 10^{-6})^2}{10} = 10^{-11} \text{ W}$$

With the buffer amplifier:

$$v_o = 1 \times \frac{R_i}{R_i + R_s} \times A_{vo} \times \frac{R_L}{R_L + R_o}$$

$$= 1 \times \frac{1}{1+1} \times 1 \times \frac{10}{10+10} = 0.25 \text{ V}$$

$$P_L = \frac{v_o^2}{R_L} = \frac{0.25^2}{10} = 6.25 \text{ mW}$$

Voltage gain =  $\frac{v_o}{v_s} = \frac{0.25 \text{ V}}{1 \text{ V}} = 0.25 \text{ V/V}$

= -12 dB

Power gain ( $A_p$ )  $\equiv \frac{P_L}{P_i}$

where  $P_L = 6.25 \text{ mW}$  and  $P_i = v_i i_1$ ,

$v_i = 0.5 \text{ V}$  and

$$i_1 = \frac{1 \text{ V}}{1 \text{ M}\Omega + 1 \text{ M}\Omega} = 0.5 \mu\text{A}$$

Exercise 1-3

This figure belongs to Exercise 1.15.

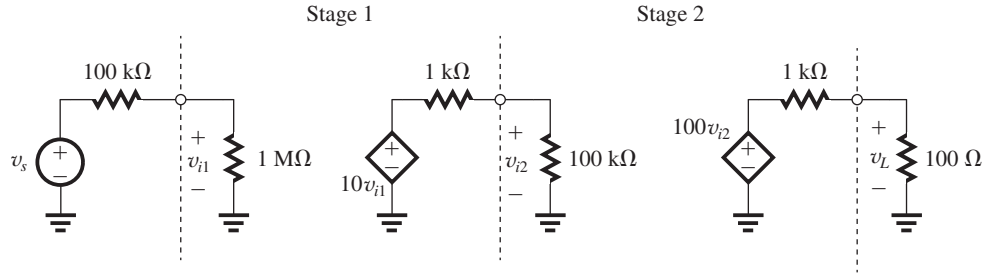

Thus,

$$P_i = 0.5 \times 0.5 = 0.25 \mu\text{W}$$

and

$$A_p = \frac{6.25 \times 10^{-3}}{0.25 \times 10^{-6}} = 25 \times 10^3$$

$$10 \log A_p = 44 \text{ dB}$$

**Ex: 1.13** Open-circuit (no load) output voltage =  $A_{vo}v_i$

Output voltage with load connected

$$= A_{vo}v_i \frac{R_L}{R_L + R_o}$$

$$0.8 = \frac{1}{R_o + 1} \Rightarrow R_o = 0.25 \text{ k}\Omega = 250 \Omega$$

**Ex: 1.14**  $A_{vo} = 40 \text{ dB} = 100 \text{ V/V}$

$$P_L = \frac{v_o^2}{R_L} = \left( A_{vo}v_i \frac{R_L}{R_L + R_o} \right)^2 / R_L$$

$$= v_i^2 \times \left( 100 \times \frac{1}{1+1} \right)^2 / 1000 = 2.5 v_i^2$$

$$P_i = \frac{v_i^2}{R_i} = \frac{v_i^2}{10,000}$$

$$A_p \equiv \frac{P_L}{P_i} = \frac{2.5v_i^2}{10^{-4}v_i^2} = 2.5 \times 10^4 \text{ W/W}$$

$$10 \log A_p = 44 \text{ dB}$$

**Ex: 1.15** Without stage 3 (see figure above)

$$\frac{v_L}{v_s} = \left( \frac{1 \text{ M}\Omega}{100 \text{ k}\Omega + 1 \text{ M}\Omega} \right) (10) \left( \frac{100 \text{ k}\Omega}{100 \text{ k}\Omega + 1 \text{ k}\Omega} \right) \times (100) \left( \frac{100}{100 + 1 \text{ k}\Omega} \right)$$

$$\frac{v_L}{v_s} = (0.909)(10)(0.9901)(100)(0.0909)$$

$$= 81.8 \text{ V/V}$$

**Ex: 1.16** Refer the solution to Example 1.3 in the text.

$$\frac{v_{i1}}{v_s} = 0.909 \text{ V/V}$$

$$v_{i1} = 0.909 v_s = 0.909 \times 1 = 0.909 \text{ mV}$$

$$\frac{v_{i2}}{v_s} = \frac{v_{i2}}{v_{i1}} \times \frac{v_{i1}}{v_s} = 9.9 \times 0.909 = 9 \text{ V/V}$$

$$v_{i2} = 9 \times v_s = 9 \times 1 = 9 \text{ mV}$$

$$\frac{v_{i3}}{v_s} = \frac{v_{i3}}{v_{i2}} \times \frac{v_{i2}}{v_{i1}} \times \frac{v_{i1}}{v_s} = 90.9 \times 9.9 \times 0.909$$

$$= 818 \text{ V/V}$$

$$v_{i3} = 818 v_s = 818 \times 1 = 818 \text{ mV}$$

$$\frac{v_L}{v_s} = \frac{v_L}{v_{i3}} \times \frac{v_{i3}}{v_{i2}} \times \frac{v_{i2}}{v_{i1}} \times \frac{v_{i1}}{v_s}$$

$$= 0.909 \times 90.9 \times 9.9 \times 0.909 \simeq 744 \text{ V/V}$$

$$v_L = 744 \times 1 \text{ mV} = 744 \text{ mV}$$

**Ex: 1.17** Using voltage amplifier model, the three-stage amplifier can be represented as

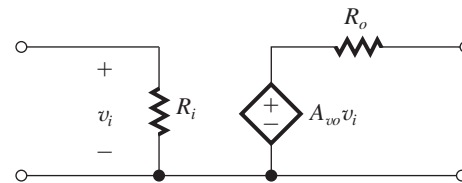

$$R_i = 1 \text{ M}\Omega$$

$$R_o = 10 \Omega$$

$$A_{vo} = A_{v1} \times A_{v2} \times A_{v3} = 9.9 \times 90.9 \times 1 = 900 \text{ V/V}$$

The overall voltage gain

$$\frac{v_o}{v_s} = \frac{R_i}{R_i + R_s} \times A_{vo} \times \frac{R_L}{R_L + R_o}$$

Exercise 1-4

For  $R_L = 10 \Omega$

Overall voltage gain

$$= \frac{1 \text{ M}}{1 \text{ M} + 100 \text{ K}} \times 900 \times \frac{10}{10 + 10} = 409 \text{ V/V}$$

For  $R_L = 1000 \Omega$

Overall voltage gain

$$= \frac{1 \text{ M}}{1 \text{ M} + 100 \text{ K}} \times 900 \times \frac{1000}{1000 + 10} = 810 \text{ V/V}$$

$\therefore$  Range of voltage gain is from 409 V/V to 810 V/V.

**Ex: 1.18**

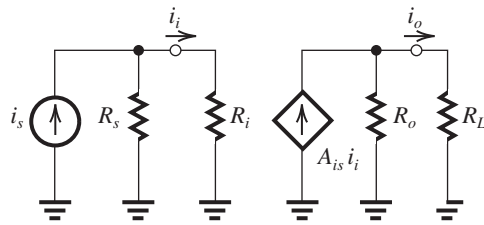

$$i_i = i_s \frac{R_s}{R_s + R_i}$$

$$i_o = A_{is} i_i \frac{R_o}{R_o + R_L} = A_{is} i_s \frac{R_s}{R_s + R_i} \frac{R_o}{R_o + R_L}$$

Thus,

$$\frac{i_o}{i_s} = A_{is} \frac{R_s}{R_s + R_i} \frac{R_o}{R_o + R_L}$$

**Ex: 1.19**

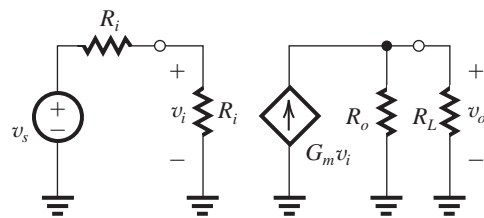

$$v_i = v_s \frac{R_i}{R_i + R_s}$$

$$v_o = G_m v_i (R_o \parallel R_L)$$

$$= G_m v_s \frac{R_i}{R_i + R_s} (R_o \parallel R_L)$$

Thus,

$$\frac{v_o}{v_s} = G_m \frac{R_i}{R_i + R_s} (R_o \parallel R_L)$$

**Ex: 1.20** Using the transresistance circuit model, the circuit will be

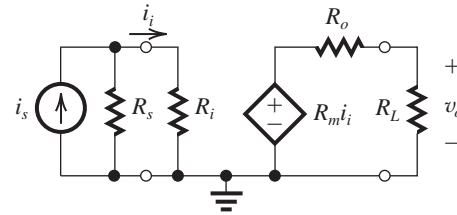

$$\frac{i_i}{i_s} = \frac{R_s}{R_i + R_s}$$

$$v_o = R_m i_i \times \frac{R_L}{R_L + R_o}$$

$$\frac{v_o}{i_i} = R_m \frac{R_L}{R_L + R_o}$$

$$\text{Now } \frac{v_o}{i_s} = \frac{v_o}{i_i} \times \frac{i_i}{i_s} = R_m \frac{R_L}{R_L + R_o} \times \frac{R_s}{R_i + R_s}$$

$$= R_m \frac{R_s}{R_s + R_i} \times \frac{R_L}{R_L + R_o}$$

**Ex: 1.21**

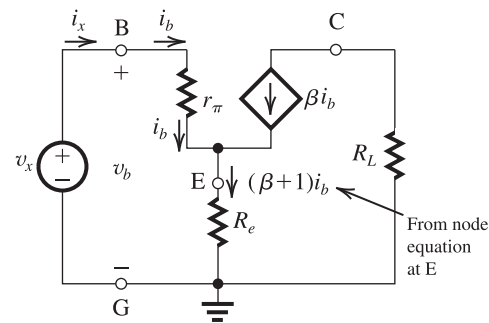

$$v_b = i_b r_\pi + (\beta + 1) i_b R_e$$

$$= i_b r_\pi + (\beta + 1) R_e$$

But  $v_b = v_x$  and  $i_b = i_x$ , thus

$$R_{in} \equiv \frac{v_x}{i_x} = \frac{v_b}{i_b} = r_\pi + (\beta + 1) R_e$$

**Ex: 1.22**

$f$	Gain
10 Hz	60 dB
10 kHz	40 dB
100 kHz	20 dB
1 MHz	0 dB

Exercise 1-5

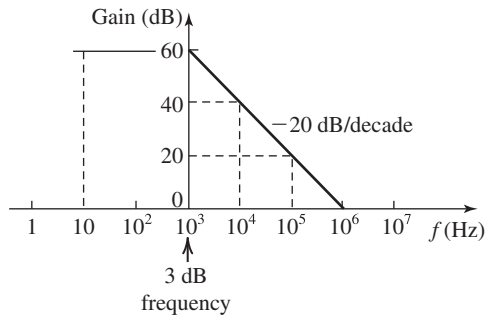

**Ex: 1.23**

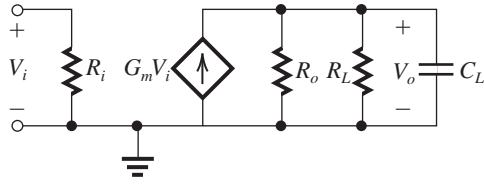

$$V_o = G_m V_i R_o \parallel R_L \parallel C_L$$

$$= \frac{G_m V_i}{\frac{1}{R_o} + \frac{1}{R_L} + sC_L}$$

$$\text{Thus, } \frac{V_o}{V_i} = \frac{G_m}{\frac{1}{R_o} + \frac{1}{R_L}} \times \frac{1}{1 + \frac{sC_L}{\frac{1}{R_o} + \frac{1}{R_L}}}$$

$$\frac{V_o}{V_i} = \frac{G_m (R_L \parallel R_o)}{1 + sC_L (R_L \parallel R_o)}$$

which is of the STC LP type.

$$\omega_0 = \frac{1}{C_L (R_L \parallel R_o)}$$

$$= \frac{1}{4.5 \times 10^{-9} (10^3 \parallel R_o)}$$

For  $\omega_0$  to be at least  $\omega\pi \times 40 \times 10^3$ , the highest value allowed for  $R_o$  is

$$R_o = \frac{10^3}{2\pi \times 40 \times 10^3 \times 10^3 \times 4.5 \times 10^{-9} - 1}$$

$$= \frac{10^3}{1.131 - 1} = 7.64 \text{ k}\Omega$$

The dc gain is

$$G_m (R_L \parallel R_o)$$

To ensure a dc gain of at least 40 dB (i.e., 100), the minimum value of  $G_m$  is

$$\Rightarrow R_L \geq 100 / (10^3 \parallel 7.64 \times 10^3) = 113.1 \text{ mA/V}$$

**Ex: 1.24** Refer to Fig. E1.24

$$\frac{V_2}{V_s} = \frac{R_i}{R_s + \frac{1}{sC} + R_i} = \frac{R_i}{R_s + R_i} \frac{s}{s + \frac{1}{C(R_s + R_i)}}$$

which is an HP STC function.

$$f_{3\text{dB}} = \frac{1}{2\pi C (R_s + R_i)} \leq 100 \text{ Hz}$$

$$C \geq \frac{1}{2\pi (1 + 9)10^3 \times 100} = 0.16 \mu\text{F}$$