

Section 1.2: Charge, Current, and Voltage

Problem 1.1

A free electron has an initial potential energy per unit charge (voltage) of 17 kJ/C and a velocity of 93 Mm/s. Later, its potential energy per unit charge is 6 kJ/C. Determine the change in velocity of the electron.

Solution:

Known quantities:

Initial Coulombic potential energy, $V_i = 17 \text{ kJ/C}$; initial velocity, $U_i = 93 \text{ M} \frac{\text{m}}{\text{s}}$; final Coulombic potential energy, $V_f = 6 \text{ kJ/C}$.

Find:

The change in velocity of the electron.

Assumptions:

$$\Delta PE_g \ll \Delta PE_c$$

Analysis:

Using the first law of thermodynamics, we obtain the final velocity of the electron:

$$Q_{\text{heat}} - W = \Delta KE + \Delta PE_c + \Delta PE_g + \dots$$

Heat is not applicable to a single particle. $W=0$ since no external forces are applied.

$$\Delta KE = -\Delta PE_c$$

$$\frac{1}{2} m_e (U_f^2 - U_i^2) = -Q_e (V_f - V_i)$$

$$U_f^2 = U_i^2 - \frac{2Q_e}{m_e} (V_f - V_i)$$

$$= \left(93 \text{ M} \frac{\text{m}}{\text{s}} \right)^2 - \frac{2(-1.6 \times 10^{-19} \text{ C})}{9.11 \times 10^{-31} \text{ kg}} (6 \text{ kV} - 17 \text{ kV})$$

$$= 8.649 \times 10^{15} \frac{\text{m}^2}{\text{s}^2} - 3.864 \times 10^{15} \frac{\text{m}^2}{\text{s}^2}$$

$$U_f = 6.917 \times 10^7 \frac{\text{m}}{\text{s}}$$

$$|U_f - U_i| = 93 \text{ M} \frac{\text{m}}{\text{s}} - 69.17 \text{ M} \frac{\text{m}}{\text{s}} = 23.83 \text{ M} \frac{\text{m}}{\text{s}}$$

Problem 1.2

The units for voltage, current, and resistance are the volt (V), the ampere (A), and the ohm (Ω), respectively. Express each unit in fundamental MKS units.

Solution:

Known quantities:

MKSQ units.

Find:

Equivalent units of volt, ampere, and ohm.

Analysis:

$$\text{Voltage} = \text{Volt} = \frac{\text{Joule}}{\text{Coulomb}} \quad V = \frac{J}{C}$$

$$\text{Current} = \text{Ampere} = \frac{\text{Coulomb}}{\text{second}} \quad a = \frac{C}{s}$$

$$\text{Resistance} = \text{Ohm} = \frac{\text{Volt}}{\text{Ampere}} = \frac{\text{Joule} \times \text{second}}{\text{Coulomb}^2} \quad \Omega = \frac{J \cdot s}{C^2}$$

$$\text{Conductance} = \text{Siemens or Mho} = \frac{\text{Ampere}}{\text{Volt}} = \frac{C^2}{J \cdot s}$$

Problem 1.3

A particular fully charged battery can deliver 2.7×10^6 coulombs of charge.

Solution:

Known quantities:

$$Q_{\text{Battery}} = 2.7 \cdot 10^6 \text{ C.}$$

Find:

- The capacity of the battery in ampere-hours
- The number of electrons that can be delivered.

Analysis:

- There are 3600 seconds in one hour. Amperage is defined as 1 Coulomb per second and is directly proportional to ampere-hours.

$$2.7 \cdot 10^6 \text{ C} \cdot \frac{1 \text{ hr}}{3600 \text{ s}} = 750 \text{ AH}$$

- The charge of a single electron is $-1.602 \cdot 10^{-19}$ C. The negative sign is negligible. Simple division gives the solution:

$$\frac{2.7 \cdot 10^6 \text{ C}}{1.602 \cdot 10^{-19} \text{ C}} = 1.685 \cdot 10^{25} \text{ electrons}$$

Problem 1.4

The charge cycle shown in Figure P1.4 is an example of a three-rate charge. The current is held constant at 30 mA for 6 h. Then it is switched to 20 mA for the next 3 h.

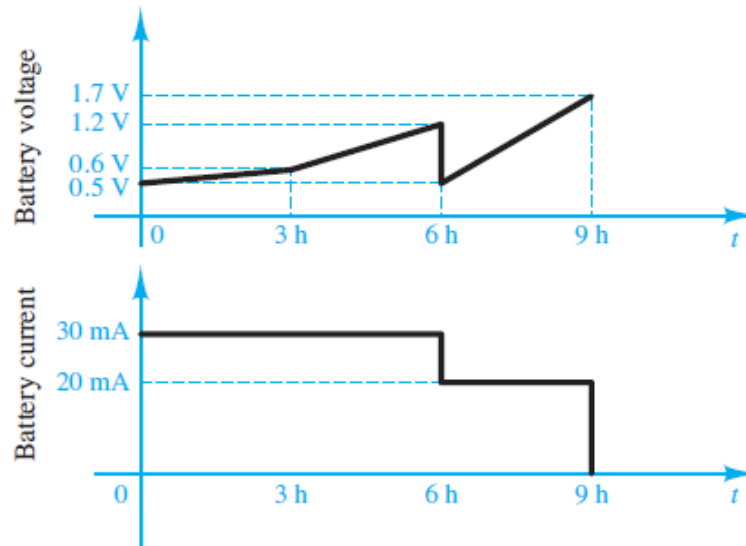

Figure P1.4

Solution:

Known quantities:

See Figure P1.4

Find:

- The total charge transferred to the battery.
- The energy transferred to the battery.

Analysis:

- Current is equal to $\frac{\text{Coulombs}}{\text{Second}}$, therefore given a constant current and a duration of that current, the transferred charge can be calculated by the following equation:

$$A \cdot t = C$$

The two durations should be calculated independently and then added together.

$$0.030A \cdot 21600s = 648C$$

$$0.020A \cdot 10800s = 216C$$

$$648C + 216C = \mathbf{864C}$$

- $P=V \cdot I$, therefore, the total energy can be calculated as sum of the products of the average voltage, the average current, and the interval length over all three intervals. Note the conversion from hours to seconds.

$$U=V \cdot I \cdot \Delta t = (0.55 \cdot 0.030 \cdot 3600 \cdot 3) + (0.9 \cdot 0.030 \cdot 3600 \cdot 3) + (1.1 \cdot 0.020 \cdot 3600 \cdot 3) = 707.4J$$

Problem 1.5

Batteries (e.g., lead-acid batteries) store chemical energy and convert it to electric energy on demand. Batteries do not store electric charge or charge carriers. Charge carriers (electrons) enter one terminal of the battery, acquire electrical potential energy, and exit from the other terminal at a lower voltage. Remember the electron has a negative charge! It is convenient to think of positive carriers flowing in the opposite direction, that is, conventional current, and exiting at a higher voltage. (Benjamin Franklin caused this mess!) For a battery with a rated voltage = 12 V and a rated capacity = 350 A-h, determine:

- The rated chemical energy stored in the battery.
- The total charge that can be supplied at the rated

Solution:

Known quantities:

Rated voltage of the battery; rated capacity of the battery.

Find:

- The rated chemical energy stored in the battery
- The total charge that can be supplied at the rated voltage.

Analysis:

a)

$$\Delta V \equiv \frac{\Delta PE_c}{\Delta Q} \quad I = \frac{\Delta Q}{\Delta t}$$

$$\text{Chemical energy} = \Delta PE_c = \Delta V \cdot \Delta Q = \Delta V \cdot (I \cdot \Delta t)$$

$$= 12 \text{ V} \cdot 350 \text{ A} \cdot \text{hr} \cdot 3600 \frac{\text{s}}{\text{hr}} = 15.12 \text{ MJ}.$$

As the battery discharges, the voltage will decrease below the rated voltage. The remaining chemical energy stored in the battery is less useful or not useful.

b) ΔQ is the total charge passing through the battery and gaining 12 J/C of electrical energy.

$$\Delta Q = I \cdot \Delta t = 350 \text{ A} \cdot \text{hr} = 350 \frac{\text{C}}{\text{s}} \cdot \text{hr} \cdot 3600 \frac{\text{s}}{\text{hr}} = 1.26 \text{ MC}.$$

Problem 1.6

What determines:

- The current through an ideal voltage source?
- The voltage across an ideal current source?

Solution:

Known quantities:

Resistance of external circuit.

Find:

- Current through an ideal voltage source
- Voltage across an ideal current source.

Assumptions:

Ideal voltage and current sources.

Analysis:

a) An ideal voltage source produces a constant voltage at or below its rated current. Current is determined by the power required by the external circuit (modeled as R).

$$I = \frac{V_s}{R}, \quad P = V_s \cdot I$$

b) An ideal current source produces a constant current at or below its rated voltage. Voltage is determined by the power demanded by the external circuit (modeled as R).

$$V = I_s \cdot R, \quad P = V \cdot I_s$$

A real source will overheat and, perhaps, burn up if its rated power is exceeded.

Problem 1.7

An automotive battery is rated at 120 A-h. This means that under certain test conditions it can output 1 A at 12 V for 120 h (under other test conditions, the battery may have other ratings).

a. How much total energy is stored in the battery?

b. If the headlights are left on overnight (8 h), how much energy will still be stored in the battery in the morning? (Assume a 150-W total power rating for both headlights together.)

Solution:**Known quantities:**

Rated discharge current of the battery; rated voltage of the battery; rated discharge time of the battery.

Find:

- Energy stored in the battery when fully recharging
- Energy stored in the battery after discharging

Analysis:

$$a) \text{ Energy} = \text{Power} \times \text{time} = (1A)(12V)(120\text{hr}) \left(\frac{60 \text{ min}}{\text{hr}} \right) \left(\frac{60 \text{ sec}}{\text{min}} \right)$$

$$w = 5.184 \times 10^6 \text{ J}$$

b) Assume that 150 W is the combined power rating of both lights; then,

$$w_{\text{used}} = (150W)(8\text{hrs}) \left(\frac{3600 \text{ sec}}{\text{hr}} \right) = 4.32 \times 10^6 \text{ J}$$

$$w_{\text{stored}} = w - w_{\text{used}} = 864 \times 10^3 \text{ J}$$

Problem 1.8

A car battery kept in storage in the basement needs recharging. If the voltage and the current provided by the charger during a charge cycle are shown in Figure P1.8,

- Find the total charge transferred to the battery.
- Find the total energy transferred to the battery.

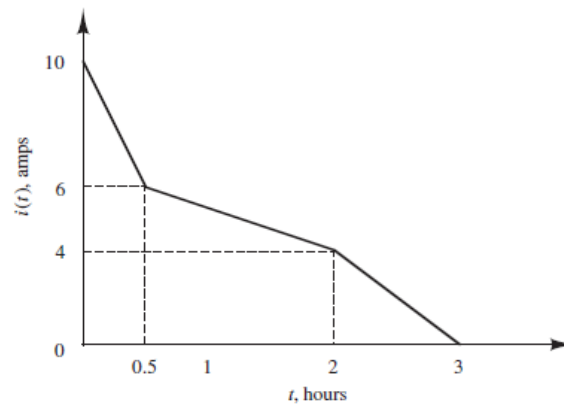
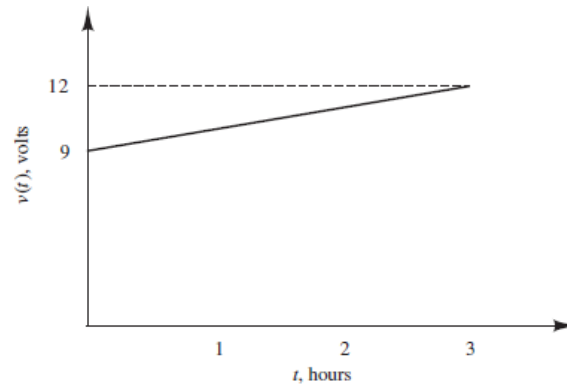

Figure P1.8

Solution:

Known quantities:

Recharging current and recharging voltage

Find:

- a) Total transferred charge
- b) Total transferred energy

Analysis:

$$Q = \text{area under the current - time curve} = \int I dt$$

$$a) = \frac{1}{2}(4)(30)(60) + 6(30)(60) + \frac{1}{2}(2)(90)(60) + 4(90)(60) + \frac{1}{2}(4)(60)(60) = 48,600 \text{ C}$$

$$\boxed{Q = 48,600 \text{ C}}$$

$$b) \frac{dw}{dt} = p \text{ SO } w = \int p dt = \int v i dt$$

$$v = 9 + \frac{3}{10800} t \quad \text{V}, \quad 0 \leq t \leq 10800 \text{ s}$$

$$i_1 = 10 - \frac{4}{1800} t \quad \text{A}, \quad 0 \leq t \leq 1800 \text{ s}$$

$$i_2 = 6 - \frac{2}{5400} t \quad \text{A}, \quad 1800 \leq t \leq 7200 \text{ s}$$

$$i_3 = 12 - \frac{4}{3600} t \quad \text{A}, \quad 7200 \leq t \leq 10800 \text{ s}$$

where $i = i_1 + i_2 + i_3$

Therefore,

$$\begin{aligned} w &= \int_0^{1800} v i_1 dt + \int_{1800}^{7200} v i_2 dt + \int_{7200}^{10800} v i_3 dt \\ &= \left(90t + \frac{t^2}{720} - \frac{t^2}{100} - \frac{t^3}{4.86 \times 10^6} \right) \Big|_0^{1800} \\ &\quad + \left(60t + \frac{t^2}{1080} - \frac{t^2}{600} - \frac{t^3}{29.16 \times 10^6} \right) \Big|_{1800}^{7200} \\ &\quad + \left(108t + \frac{t^2}{600} - \frac{t^2}{200} - \frac{t^3}{9.72 \times 10^6} \right) \Big|_{7200}^{10800} \\ &= 132.9 \times 10^3 + 380.8 \times 10^3 - 105.4 \times 10^3 + 648 \times 10^3 - 566.4 \times 10^3 \end{aligned}$$

$$\boxed{\text{Energy} = 489.9 \text{ kJ}}$$

Problem 1.9

Suppose the current through a wire is given by the curve shown in Figure P1.9.

- Find the amount of charge, q , that flows through the wire between $t_1 = 0$ and $t_2 = 1$ s.
- Repeat part a for $t_2 = 2, 3, 4, 5, 6, 7, 8, 9$, and 10 s.
- Sketch $q(t)$ for $0 \leq t \leq 10$ s.

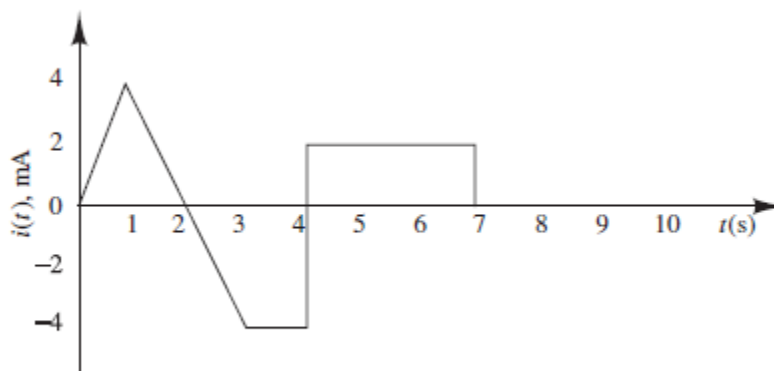

Figure P1.9

Solution:

Known quantities:

Current-time curve

Find:

- a) Amount of charge during 1st second
- b) Amount of charge for 2 to 10 seconds
- c) Sketch charge-time curve

Analysis:

a) $i = \frac{4 \times 10^{-3} t}{1}$

$$Q_1 = \int_0^1 i dt = \int_0^1 4 \times 10^{-3} t dt = 4 \times 10^{-3} \frac{t^2}{2} \Big|_0^1 = 2 \times 10^{-3} \frac{\text{amp}}{\text{sec}} = 2 \times 10^{-3} \text{ Coulombs}$$

b) The charge transferred from $t = 1$ to $t = 2$ is the same as from $t = 0$ to $t = 1$.

$Q_2 = 4 \times 10^{-3} \text{ Coulombs}$

The charge transferred from $t = 2$ to $t = 3$ is the same in magnitude and opposite in direction to that from $t = 1$ to $t = 2$. $Q_3 = 2 \times 10^{-3} \text{ Coulombs}$

$t = 4$
 $Q_4 = 2 \times 10^{-3} - \int_3^4 4 \times 10^{-3} dt = 2 \times 10^{-3} - 4 \times 10^{-3} = -2 \times 10^{-3} \text{ Coulombs}$
 $t = 5, 6, 7$

$Q_5 = -2 \times 10^{-3} + \int_4^5 2 \times 10^{-3} dt = 0$

$Q_6 = 0 + \int_5^6 2 \times 10^{-3} dt = 2 \times 10^{-3} \text{ Coulombs}$

$Q_7 = 2 \times 10^{-3} + \int_6^7 2 \times 10^{-3} dt = 4 \times 10^{-3} \text{ Coulombs}$
 $t = 8, 9, 10s$

$Q = 4 \times 10^{-3} \text{ Coulombs}$

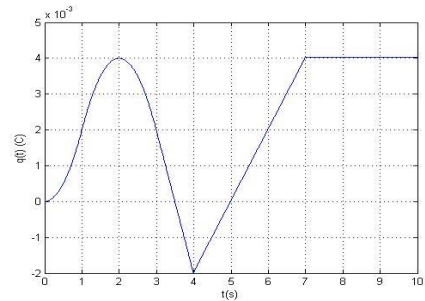

Problem 1.10

The charge cycle shown in Figure P1.10 is an example of a two-rate charge. The current is held constant at 70 mA for 1 h. Then it is switched to 60 mA for the next 1 h.

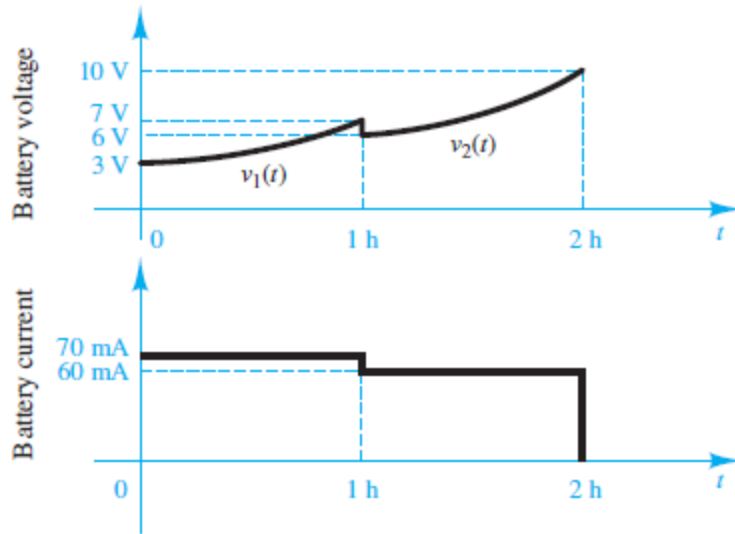

Figure P1.10

Solution:

Known quantities:

See Figure P1.10

Find:

- The total charge transferred to the battery.
- The total energy transferred to the battery.

Analysis:

- Current is equal to $\frac{\text{Coulombs}}{\text{Second}}$, therefore given a constant current and a duration of that current, the transferred charge can be calculated by the following equation:

$$A \cdot t = C$$

The two durations should be calculated independently and then added together.

$$0.070A \cdot 3600s = 252C$$

$$0.060A \cdot 3600s = 216C$$

$$252C + 216C = 468C$$

- $P=V \cdot I$, therefore, an equation for power can be found by multiplying the two graphs together.

First separate the voltage graph into three equations:

$$0 \text{ h} \rightarrow 1 \text{ h} : V = 5 + e^{t/5194.8} \text{ V}$$

$$1 \text{ h} \rightarrow 2 \text{ h} : V = \left(6 - \frac{4}{e^{1h}-1}\right) + \frac{4}{e^{2h}-e^{1h}} * e^t \text{ V}$$

Next, multiply the first equation by 0.07A and the second by 0.06A.

$$0 \text{ h} \rightarrow 1 \text{ h} : P = 0.35 + 0.07e^{t/5194.8}$$

$$1 \text{ h} \rightarrow 2 \text{ h} : P = 0.06 \left(6 - \frac{4}{e^{1h}-1}\right) + 0.06 \frac{4}{e^{2h}-e^{1h}} * e^t \text{ V}$$

Finally, since Energy is equal to the integral of power, take the integral of each of the equations for their specified times and add them together.

$$0 \text{ h} \rightarrow 1 \text{ h} : E = \left[0.35t + 363.64e^{t/5194.8}\right]_0^{3600} = 1623.53 \text{ J}$$

$$1 \text{ h} \rightarrow 2 \text{ h} : E = [0.36t + 2.88 * 10^{-3128} * 2.72^t]_{3600}^{7200} = 1296.24 \text{ J}$$

$$E_{Total} = 2919.77 \text{ J}$$

Problem 1.11

The charging scheme used in Figure P1.11 is an example of a constant-current charge cycle. The charger voltage is controlled such that the current into the battery is held constant at 40 mA, as shown in Figure P1.11. The battery is charged for 6 h. Find:

- The total charge delivered to the battery.
- The energy transferred to the battery during the charging cycle.

Hint: Recall that the energy, w , is the integral of power, or $P = dw/dt$.

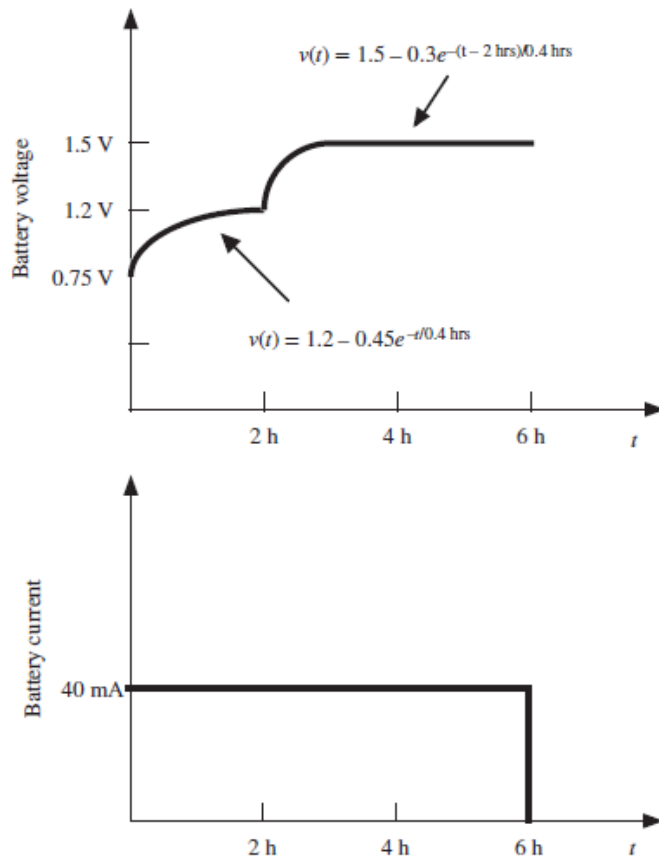

Figure P1.11

Solution:

Known quantities:

Current-time curve and voltage-time curve of battery recharging

Find:

- a) Total transferred charge
- b) Total transferred energy

Analysis:

a) $40 \text{ mA} = 0.04 \text{ A}$

$Q = \text{area under the current-time curve} = \int I dt = (0.04)(6)(3600) = 864 \text{ C}$

$Q = 864 \text{ C}$

b) $\frac{dw}{dt} = P$ so

$w = \int P dt = \int v i dt = (3600) \int_0^2 v i dt + (3600) \int_2^6 v i dt$

$= (3600) \int_0^2 (1.2 - 0.45e^{-t/0.4})(0.04) dt + (3600) \int_2^6 (1.5 - 0.3e^{-(t-2)/0.4})(0.04) dt$

$= 1,167 \text{ J}$

$$\text{Energy} = 1,167\text{J}$$

Problem 1.12

The charging scheme used in Figure P1.12 is called a tapered-current charge cycle. The current starts at the highest level and then decreases with time for the entire charge cycle, as shown.

The battery is charged for 12 h. Find:

- The total charge delivered to the battery.
- The energy transferred to the battery during the charging cycle.

Hint: Recall that the energy, w , is the integral of power, or $P = dw/dt$.

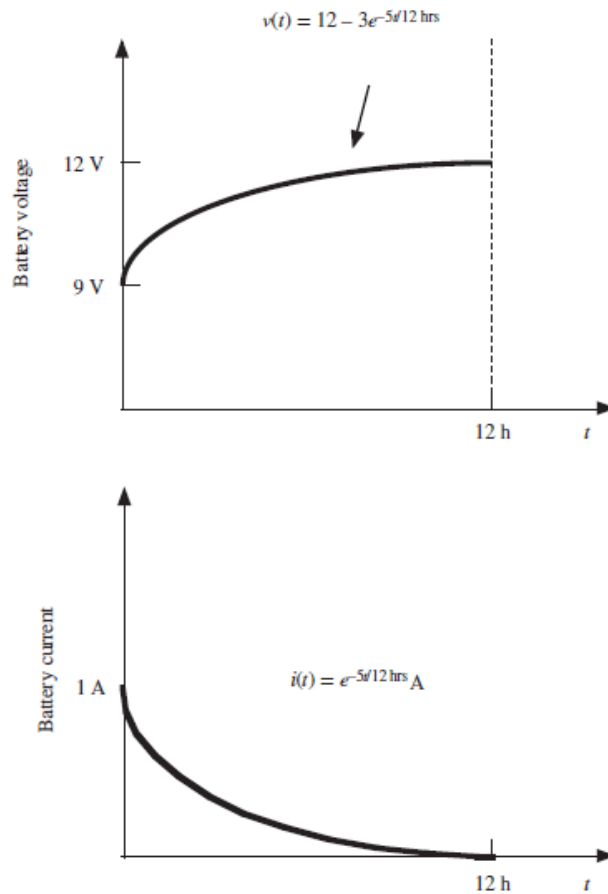

Figure P1.12

Solution:

Known quantities:

Current-time curve and voltage-time curve of battery recharging

Find:

- a) Total transferred charge
- b) Total transferred energy

Analysis:

a) $Q = \int_0^{12} I dt = (3600) \int_0^{12} e^{-5t/12} dt = 8,564 \text{ C}$

$Q = 8,564 \text{ C}$

b) $\frac{dw}{dt} = P$ so

$$w = \int_0^{12} P dt = \int_0^{12} v i dt = (3600) \int_0^{12} (12 - 3e^{-5t/12}) (e^{-5t/12}) dt$$

$= 8,986 \text{ J}$

$\text{Energy} = 8,986 \text{ J}$

Section 1.4: Power and the Passive Sign Convention

Problem 1.13

Find the power delivered by the source in Figure P1.13.

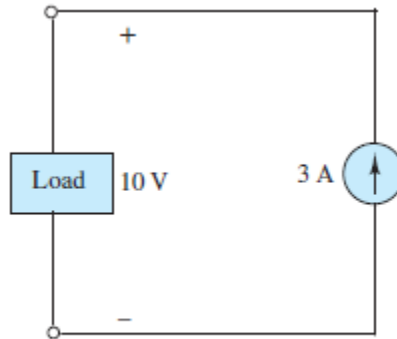

Figure P1.13

Solution:

Known quantities:

Circuit shown in Figure P1.13.

Find:

Power delivered by the 3A current source.

Analysis:

Follow the counterclockwise current:

$$P = (+3A) \cdot (+10V)$$

$$P = +30W \text{ supplied}$$

Problem 1.14

Find the power delivered by each source in Figure P1.14.

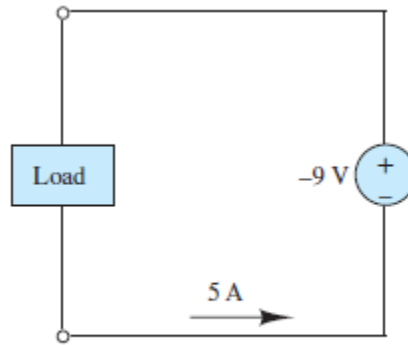

Figure P1.14

Solution:

Known quantities:

Circuits shown in Figure P1.14.

Find:

Power delivered by the -9V Voltage Source

Analysis:

Follow the counterclockwise current:

$$P = (+5A) \cdot (-9V)$$

$$P = -45W \text{ supplied}$$

Problem 1.15

Determine whether each element in Figure P1.15 is supplying or dissipating power, and how much.

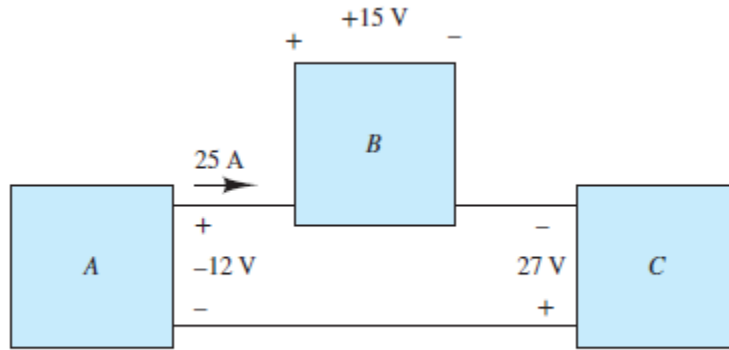

Figure P1.15

Solution:

Known quantities:

Circuit shown in Figure P1.15.

Find:

Determine power dissipated or supplied for each power source.

Analysis:

Element A:

$$P = -vi = -(-12V)(25A) = 300W \text{ (dissipating)}$$

Element B:

$$P = vi = (15V)(25A) = 375W \text{ (dissipating)}$$

Element C:

$$P = vi = (27V)(25A) = 675W \text{ (supplying)}$$

Problem 1.16

In the circuit of Figure P1.16, find the power absorbed by the resistor R_4 and the power delivered by the current source.

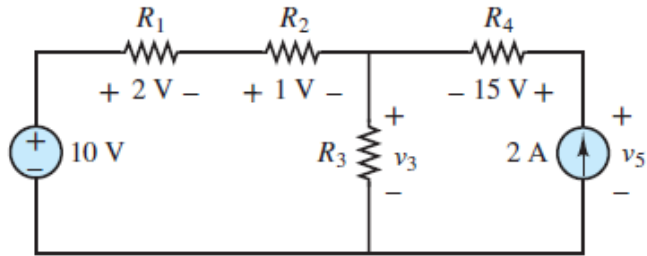

Figure P1.16

Solution:

Known quantities:

Circuit shown in Figure P1.16.

Find:

- a) Power absorbed by R_4
- b) Power supplied by the current source

Analysis:

- a) Follow the counterclockwise current in the rightmost loop:

$$P = (2A) \cdot (15V)$$

$$P = 30W \text{ absorbed}$$

- b) Use KVL at the leftmost loop to find V_3 :

$$10V - 2V - 1V - V_3 = 0$$

$$V_3 = 7V$$

Use KVL at the rightmost loop to find V_5 :

$$7V + 15V - V_5 = 0$$

$$V_5 = 22V$$

Remember that the power calculations are based upon the passive sign convention, in which current is directed from high to low potential. Positive power is power absorbed by an element. Since V_5 is positive the current is directed from low to high potential such that power is supplied by the current source.

$$P = -(+2A) \cdot (22V) = +44W \text{ supplied}$$

Problem 1.17

For the circuit shown in Figure P1.17:

- a. Determine whether each component is absorbing or delivering power.
- b. Is conservation of power satisfied? Explain your answer.

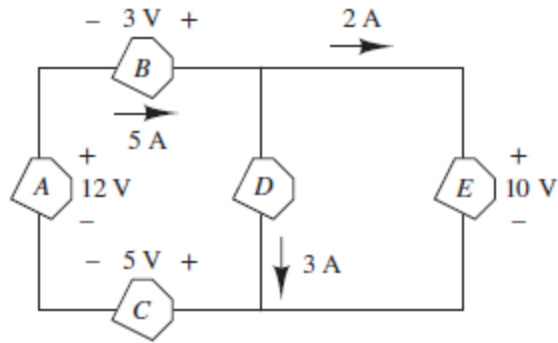

Figure P1.17

Solution:

Known quantities:

Circuit shown in Figure P1.17.

Find:

- a) Determine power absorbed or power delivered
- b) Testify power conservation

Analysis:

A supplies $(12V)(5A) = 60W$

B supplies $(3V)(5A) = 15W$

C absorbs $(5V)(5A) = 25W$

D absorbs $(10V)(3A) = 30W$

E absorbs $(10V)(2A) = 20W$

Total power supplied = $60W + 15W = 75W$

Total power absorbed = $25W + 30W + 20W = 75W$

Tot. power supplied = Tot. power absorbed conservation of power is satisfied.

Problem 1.18

Determine whether each element in Figure P1.18 is supplying or dissipating power, and how much.

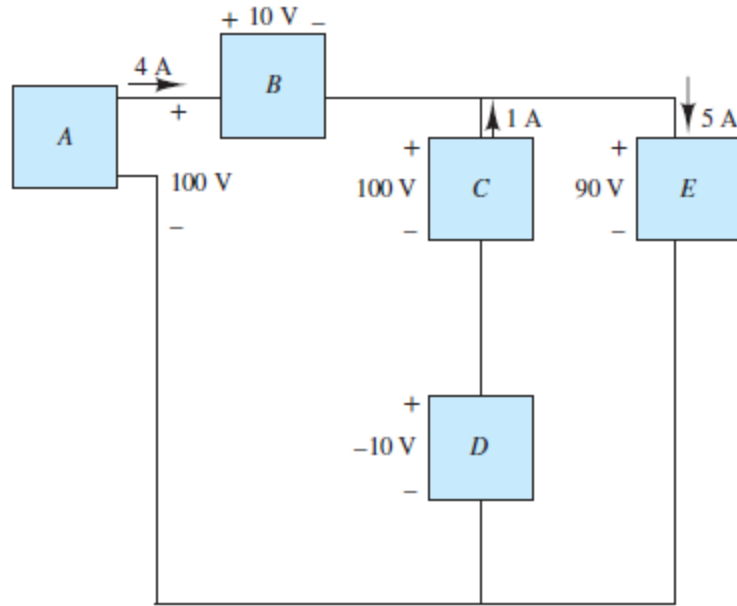

Figure P1.18

Solution:

Known quantities:

Circuit shown in Figure P1.18.

Find:

Determine power absorbed or power delivered and corresponding amount.

Analysis:

A supplies $(100V)(4A) = 400\text{ W}$

B absorbs $(10V)(4A) = 40\text{ W}$

C supplies $(100V)(1A) = 100\text{ W}$

D supplies $(-10V)(1A) = -10\text{ W}$, i.e absorbs 10 W

E absorbs $(90V)(5A) = 450\text{ W}$

Problem 1.19

Determine whether each element in Figure P1.19 is supplying or dissipating power, and how much.

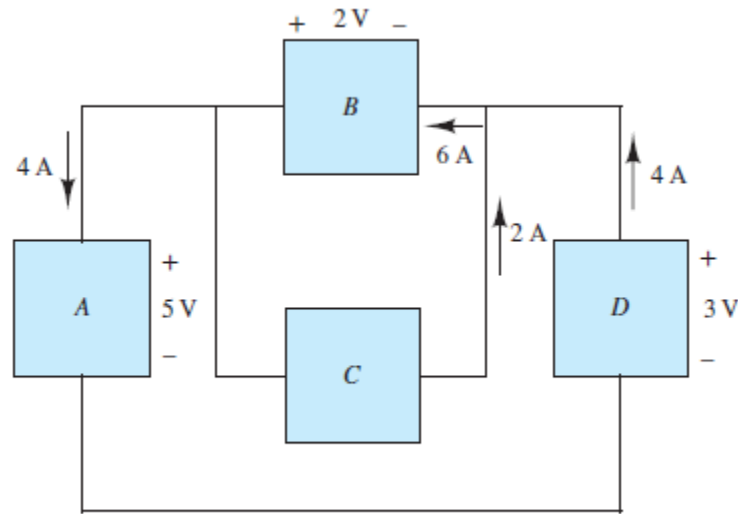

Figure P1.19

Solution:

Known quantities:

Circuit shown in Figure P1.19.

Find:

Determine power absorbed or power delivered and corresponding amount.

Analysis:

A absorbs $(5V)(4A) = 20W$

B supplies $(2V)(6A) = 12W$

C absorbs $(2V)(2A) = 4W$

D supplies $(3V)(4A) = 12W$

Since conservation of power is satisfied, Tot. power supplied = Tot. power absorbed

Total power supplied = $12W + 12W = 24W$

Problem 1.20

If an electric heater requires 23 A at 110 V, determine:

- The power it dissipates as heat or other losses.
- The energy dissipated by the heater in a 24-h period.

c. The cost of the energy if the power company charges at the rate 6 cents/kWh.

Solution:

Known quantities:

Current absorbed by the heater; voltage at which the current is supplied; cost of the energy.

Find:

- a) Power consumption
- b) Energy dissipated in 24 hr.
- c) Cost of the Energy

Assumptions:

The heater works for 24 hours continuously.

Analysis:

a) $P = VI = 110 \text{ V} (23 \text{ A}) = 2.53 \times 10^3 \frac{\text{J}}{\text{A s}} = 2.53 \text{ KW}$

b) $W = Pt = 2.53 \times 10^3 \frac{\text{J}}{\text{s}} \times 24 \text{ hr} \times 3600 \frac{\text{s}}{\text{hr}} = 218.6 \text{ MJ}$

c) $\text{Cost} = (\text{Rate}) \times W = 6 \frac{\text{cents}}{\text{kW-hr}} (2.53 \text{ kW})(24 \text{ hr}) = 364.3 \text{ cents} = \3.64

Section 1.5: Kirchhoff's Laws

Problem 1.21

For the circuit shown in Figure P1.21, determine the power absorbed by the 5 Ω resistor.

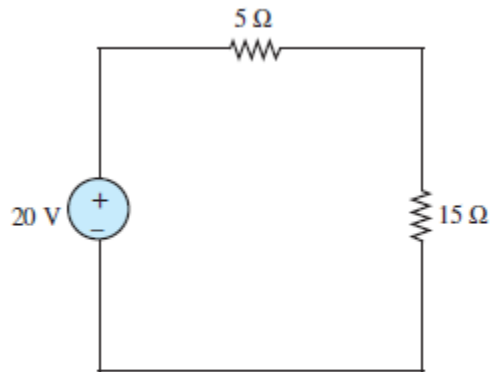

Figure P1.21

Solution:

Known quantities:

Circuit shown in Figure P1.21.

Find:

Power absorbed by the 5Ω resistance.

Analysis:

The current in the series circuit is $i = \frac{20V}{20\Omega} = 1A$.

The voltage across the 5 ohm resistor is $v_5 = (1A)(5\Omega) = 5V$.

Therefore, $P_{5\Omega} = (5V)(1A) = 5W$ absorbed. This power could also have been calculated using $P = (5V)^2/5 = (1A)^2(5) = 5W$. Note that resistors always absorb power. They cannot supply power.

Problem 1.22

Use KCL to determine the unknown currents in the circuit of Figure P1.22. Assume $i_0 = 2A$ and $i_2 = -7A$.

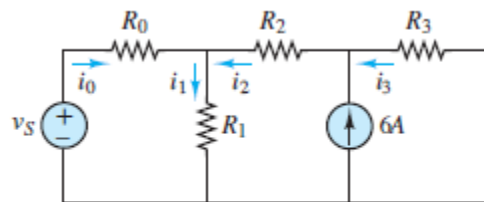

Figure P1.22

Solution:**Known quantities:**

$$i_0 = 2A, \quad i_2 = -7A$$

Find:

- i_1
- i_3

Analysis:

- Apply KCL at the node between R_0 , R_1 , and R_2 .

$$i_0 - i_1 + i_2 = 0$$

$$i_1 = i_0 + i_2$$

$$i_1 = -5A$$

- Apply KCL at the node between R_2 , R_3 , and the current source.

$$6A + i_3 - i_2 = 0$$

$$i_3 = i_2 - 6A$$

$$i_3 = -13A$$

Problem 1.23

Use KCL to find the currents i_1 and i_2 in Figure P1.23. Assume that $i_a = 3$ A, $i_b = -2$ A, $i_c = 1$ A, $i_d = 6$ A and $i_e = -4$ A.

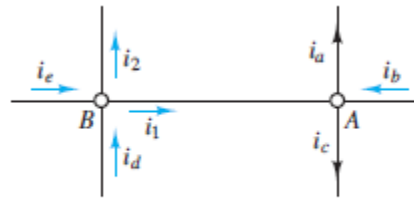

Figure P1.23

Solution:

Known quantities:

$i_a = 3$ A, $i_b = -2$ A, $i_c = 1$ A, $i_d = 6$ A, $i_e = -4$ A

Find:

- a) i_1
- b) i_2

Analysis:

- a) Use KCL at Node A.

$$i_1 + i_b - i_a - i_c = 0$$

$$i_1 = i_a - i_b + i_c$$

$$\mathbf{i_1 = 6A}$$

- b) Use KCL at Node B.

$$i_e + i_d - i_1 - i_2 = 0$$

$$i_2 = i_e + i_d - i_1$$

$$\mathbf{i_2 = -4A}$$

Problem 1.24

Use KCL to find the currents i_1 , i_2 , and i_3 in the circuit of Figure P1.24. Assume that $i_a = 2$ mA, $i_b = 7$ mA and $i_c = 4$ mA.

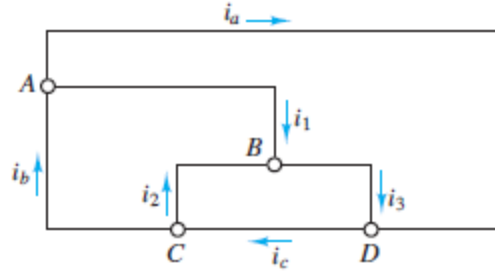

Figure P1.24

Solution:

Known quantities:

$$i_a = 2 \text{ mA}, \quad i_b = 7 \text{ mA}, \quad i_c = 4 \text{ mA}$$

Find:

- a) i_1
- b) i_2
- c) i_3

Analysis:

- a) Use KCL at Node A.

$$i_b - i_a - i_1 = 0$$

$$i_1 = i_b - i_a$$

$$i_1 = \mathbf{5 \text{ mA}}$$

- b) Use KCL at Node C.

$$i_c - i_2 - i_b = 0$$

$$i_2 = i_c - i_b$$

$$i_2 = \mathbf{-3 \text{ mA}}$$

- c) Use KCL at Node D.

$$i_3 + i_a - i_c = 0$$

$$i_3 = i_c - i_a$$

$$i_3 = \mathbf{2 \text{ mA}}$$

Problem 1.25

Use KVL to find the voltages v_1 , v_2 , and v_3 in Figure P1.25. Assume that $v_a = 2 \text{ V}$, $v_b = 4 \text{ V}$, and $v_c = 5 \text{ V}$.

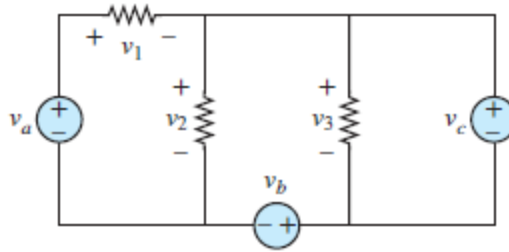

Figure P1.25

Solution:

Known quantities:

$$V_a = 2 \text{ V}, \quad V_b = 4 \text{ V}, \quad V_c = 5 \text{ V}$$

Find:

- a) V_1
- b) V_2
- c) V_3

Analysis:

- a) Apply KVL around the right mesh.

$$V_3 - V_c = 0$$

$$V_3 = V_c$$

$$\mathbf{V_3 = 5V}$$

- b) Apply KVL around the middle mesh.

$$V_2 - V_3 - V_b = 0$$

$$V_2 = V_3 + V_b$$

$$\mathbf{V_2 = 9V}$$

- c) Apply KVL around the left mesh.

$$V_a - V_1 - V_2 = 0$$

$$V_1 = V_a - V_2$$

$$\mathbf{V_1 = -7V}$$

Check these results by applying KVL around the outer loop. $2\text{V} = V_1 + 5\text{V} + 4\text{V} = 2\text{V}$. Check!

Problem 1.26

Use KCL to determine the currents i_1 , i_2 , i_3 , and i_4 in the circuit of Figure P1.26. Assume that $i_a = -2 \text{ A}$, $i_b = 6\text{A}$, $i_c = 1\text{A}$ and $i_d = -4\text{A}$.

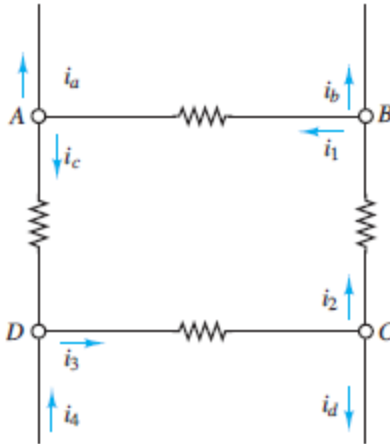

Figure P1.26

Solution:

Known quantities:

$$i_a = -2 \text{ A}, \quad i_b = 6 \text{ A}, \quad i_c = 1 \text{ A}, \quad i_d = -4 \text{ A}$$

Find:

- a) i_1
- b) i_2
- c) i_3
- d) i_4

Analysis:

- a) Use KCL at Node A.

$$i_1 - i_a - i_c = 0$$

$$i_1 = i_a + i_c$$

$$\mathbf{i_1 = -1A}$$

- b) Use KCL at Node B.

$$i_2 - i_1 - i_b = 0$$

$$i_2 = i_1 + i_b$$

$$\mathbf{i_2 = 5A}$$

- c) Use KCL at Node C.

$$i_3 - i_2 - i_d = 0$$

$$i_3 = i_2 + i_d$$

$$\mathbf{i_3 = 1A}$$

- d) Use KCL at Node D.

$$i_c + i_4 - i_3 = 0$$

$$i_4 = i_3 - i_c$$

$$\mathbf{i_4 = 0A}$$

Section 1.6 Resistance and Ohm's Law

Problem 1.27

In the circuit shown in Figure P1.27, determine the terminal voltage v_T of the source, the power absorbed by R_o , and the efficiency of the circuit. Efficiency is defined as the ratio of load power to source power.

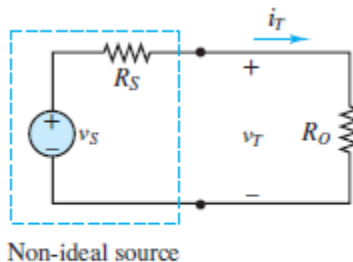

Figure P1.27

Solution:

Known quantities:

Circuit shown in Figure P1.27 with voltage source, $v_s = 12V$, internal resistance, $R_s = 5k$, and load, $R_o = 7k$.

Find:

The terminal voltage of the source; the power supplied to the circuit, the efficiency of the circuit.

Assumptions:

Assume that the only loss is due to the internal resistance of the source.

Analysis:

Apply KVL around the loop to write $v_s - i_T R_s - i_T R_o = 0$. Thus, $i_T = v_s / (R_s + R_o) = 1mA$.
Apply Ohm's law to write $v_T = i_T R_o = 7V$.

$$P_o = \frac{v_R^2}{R_o} = \frac{v_T^2}{R_o} = \frac{(7V)^2}{7 \times 10^3 \Omega} = 7 \text{ mW}$$

$$\eta = \frac{P_{out}}{P_{in}} = \frac{P_{R_o}}{P_{R_s} + P_{R_o}} = \frac{i_T^2 R_o}{i_T^2 R_s + i_T^2 R_o} = \frac{7 \text{ kW}}{5 \text{ kW} + 7 \text{ kW}} = 0.58\bar{3} \text{ or } 58.3\%.$$

Problem 1.28

A 24 V automotive battery is connected to two headlights that are in parallel, similar to that shown in Figure 1.11. Each headlight is intended to be a 75 W load; however, one 100 W headlight is mistakenly installed. What is the resistance of each headlight? What is the total current supplied by the battery?

Solution:

Known quantities:

Headlights connected in parallel to a 24 V automotive battery; power absorbed by each headlight.

Find:

Resistance of each headlight; total resistance seen by the battery.

Analysis:

Headlight no. 1:

$$I_1 = \frac{75W}{24V} = 3.125A$$
$$R_1 = \frac{24V}{3.125A} = 7.68\Omega$$

Headlight no. 2:

$$I_2 = \frac{100W}{24V} = 4.167A$$
$$R_2 = \frac{24V}{4.167A} = 5.76\Omega$$

The total current supplied by the battery is: $I = I_1 + I_2 = 7.292A$

Problem 1.29

What is the total current supplied by the battery of Problem 1.28 if two 15 W taillights are added (in parallel) to the two 75 W headlights?

Solution:

Known quantities:

Headlights and 24 V automotive battery of problem 1.13 with 2 15 W taillights added in parallel; power absorbed by each headlight; power absorbed by each taillight.

Find:

total current supplied by the battery.

Analysis:

For each 15 W tail light compute:

$$I_{3,4} = \frac{15W}{24V} = 0.625A$$

The total current supplied by the battery is $I = I_1 + I_2 + I_3 + I_4 = 8.542A$.

Problem 1.30

For the circuit shown in Figure P1.30, determine the power absorbed by the variable resistor R , ranging from 0 to $30\ \Omega$. Plot the power absorption as a function of R . Assume that $v_s = 15\text{ V}$, $R_s = 10\ \Omega$.

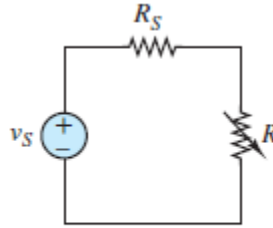

Figure P1.30

Solution:

Known quantities:

$v_s=15\text{V}$, $R_s=10\ \Omega$, and the circuit in Figure P2.30.

Find: Plot of the power absorbed by R as a function of R .

Analysis:

Use Ohm's law to find an equation for P as a function of R .

$$P_R = V_R * I_R$$

The current through R is given by Ohm's law.

$$I_R = 15/(10 + R)$$

The voltage V_R is determined by Ohm's law.

$$V_R = I_R R = \frac{(15)R}{(10 + R)}$$

Then, the power dissipated by R is

$$P_R = \left[\frac{15}{10 + R} \right] * \left[\frac{15R}{10 + R} \right] = \frac{225R}{(10 + R)^2}$$

Plot:

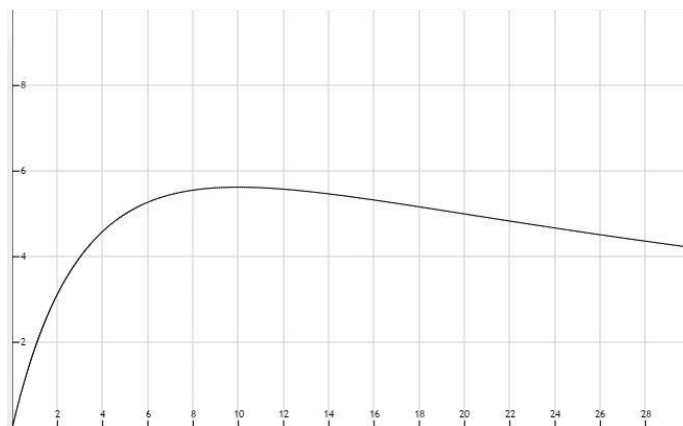

Notice that the maximum power absorbed by R occurs when $R = R_s$.

Problem 1.31

Refer to Figure P1.27 and assume that $v_s = 15 \text{ V}$ and $R_s = 100\Omega$. For $i_T = 0, 10, 20, 30, 80,$ and 100 mA :

- Find the total power supplied by the ideal source.
- Find the power dissipated within the non-ideal source.
- How much power is supplied to the load resistor?
- Plot the terminal voltage v_T and power supplied to the load resistor as a function of terminal current i_T .

Solution:

Known quantities:

$v_s = 15\text{V}$, $R_s = 100 \text{ Ohms}$, $i_T = 0, 10, 20, 30, 80, 100 \text{ mA}$. Figure P2.27.

Find:

- The total power supplied by the ideal source
- The power dissipated within the non-ideal source
- How much power is supplied to the load resistor
- Plot v_T and power supplied to R_0 as a function of i_T .

Analysis:

- The power supplied by the ideal source is equal to the current through the loop times the 15V of the supply. From current lowest to highest the power supplied would be:
 0W 0.15W 0.3W 0.45W 1.2W 1.5W
- The power dissipated within the non-ideal source is the power dissipated by R_s which can be found using $P = i^2 \cdot r$. From current lowest to highest the power dissipated would be:
 0W 0.01W 0.04W 0.09W 0.64W 1W
- The power supplied to the load resistor is equal to the total power supplied minus the power dissipated by the non-ideal source. From current lowest to highest the power supplied would be:
 0W 0.14W 0.26W 0.36W 0.56W 0.5W
- For the v_T plot Ohm's Law can be used to find the voltage drop across R_s which is equal to V_T . For the power plot, the data from part c can be used directly.



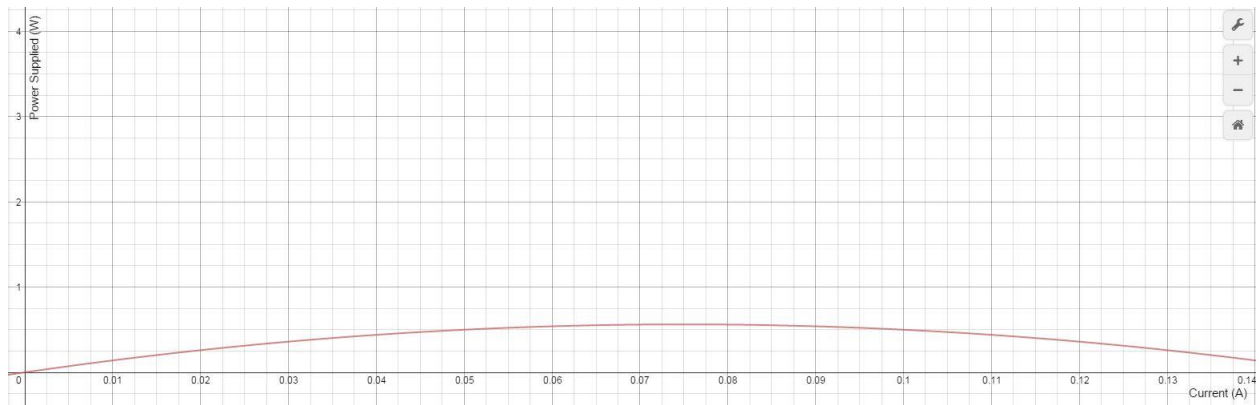

Problem 1.32

In the circuit in Figure P1.32, assume $v_2 = v_s/6$ and the power delivered by the source is 150 mW. Find R , v_s , v_2 , and i .

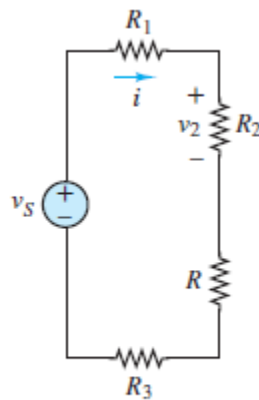

Figure P1.32

Solution:**Known quantities:**

$R_1=8k\Omega$, $R_2=10k\Omega$, $R_3=12k\Omega$ and the circuit in Figure P1.32.

Find:

R , v_s , v_2 , and i .

Analysis:

Use Ohm's law to find v_s and i :

$$v_2 = \frac{v_s}{6} = R_2 * i$$

Also:

$$v_s * i = (6R_2 i) i = 150mW$$

So:

$$i = \sqrt{\frac{150mW}{R_2 * 6}} = 1.58 \text{ mA}$$

Since we know i , v_s can easily be found:

$$\begin{aligned} v_s * i &= 150mW \\ v_s &= 94.9V \end{aligned}$$

$$v_2 = \frac{v_s}{6} = 15.8V$$

The power absorbed by each resistor can be calculated using i^2R .

Thus:

$$P_S = 150mW = i^2(R_1 + R_2 + R + R_3) = 75mW + i^2R \xrightarrow{\text{yields}} R = 30k\Omega$$

Problem 1.33

A GE SoftWhite Longlife light bulb is rated as follows:

PR = rated power = 60 W

POR = rated optical power = 820 lumens (lm) (average)

1 lumen = 1/680W

Operating life = 1,500 h (average)

VR = rated operating voltage = 115 V

The resistance of the filament of the bulb, measured with a standard multimeter, is 16.7 Ω .

When the bulb is connected into a circuit and is operating at the rated values given above, determine:

- The resistance of the filament.
- The efficiency of the bulb.

Solution:**Known quantities:**

Rated power; rated optical power; operating life; rated operating voltage; open-circuit resistance of the filament.

Find:

- The resistance of the filament in operation
- The efficiency of the bulb.

Analysis:

a) The power absorbed by a resistor can be calculated using $P = V^2/R$. Thus,

$$R = \frac{V^2}{P} = \frac{115^2}{60} = 220,4 \Omega$$

b) Efficiency is defined as the ratio of the useful power dissipated by or supplied by the load to the total power supplied by the source. In this case, the useful power supplied by the load is the optical power. From any handbook containing equivalent units: 680 lumens=1 W

$$P_{o,out} = \text{Optical Power Out} = 820 \text{ lum} \frac{\text{W}}{680 \text{ lum}} = 1.206 \text{ W}$$

$$\eta = \text{efficiency} = \frac{P_{o,out}}{P_R} = \frac{1.206 \text{ W}}{60 \text{ W}} = 0.02009 = 2.009 \%$$

Problem 1.34

An incandescent light bulb rated at 100 W is designed to dissipate 100 W as heat and light when connected across a 110-V ideal voltage source. Determine the resistance of the lightbulb when operated as designed.

Solution:**Known quantities:**

Rated power; rated voltage of a light bulb.

Find:

The resistance of the light bulb

Analysis:

the circuit can be assumed as a voltage source connect in series to the resistance due of the light bulb.

$$R = \frac{V^2}{P} = \frac{12100}{100} = 121 \Omega$$

Problem 1.35

An incandescent light bulb rated at 60 W is designed to dissipate 60 W as heat and light when connected across a 110 V ideal voltage source. A 100 W bulb is designed to dissipate 100 W when connected across the same source. Determine the resistance of each lightbulb when operated as designed.

Solution:

Known quantities:

Rated power and rated voltage of the two light bulbs.

Find:

The resistance of each of the two light bulbs in series.

Assumptions:

The resistance of each bulb doesn't vary when connected in series.

Analysis:

$$R_{100W} = \frac{V^2}{P_1} = \frac{12100}{100} = 121\Omega$$

$$R_{60W} = \frac{V^2}{P_2} = \frac{12100}{60} = 201.67\Omega$$

Problem 1.36

Refer to Figure P1.36, and assume that $v_S = 12\text{ V}$, $R_1 = 5\ \Omega$, $R_2 = 3\ \Omega$, $R_3 = 4\ \Omega$, and $R_4 = 5\ \Omega$.

Find:

- The voltage v_{ab} .
- The power dissipated in R_2 .

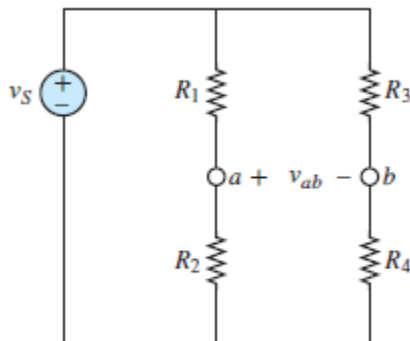

Figure P1.36