

SPE 4<sup>th</sup> Edition Solution Manual Chapter 2.

New Problems and new solutions are listed as new immediately after the solution number. These new problems are: 2A8, 2A10 parts c-e, 2A11, 2A12, 2A13, 2A14, 2C4, 2D1-part g, 2D3, 2D6, 2D7, 2D11, 2D13, 2D14, 2D20, 2D22, 2D23, 2D31, 2D32, 2E3, 2F4, 2G2, 2G3, 2H1, 2H3, 2H4, 2H5 and 2H6.

2.A1. Feed to flash drum is a liquid at high pressure. At this pressure its enthalpy can be calculated as a liquid. eg.  $h(T_{F,P_{high}}) = c_{p,LIQ} (T_F - T_{ref})$ . When pressure is dropped the mixture is above its bubble point and is a two-phase mixture (It “flashes”). In the flash mixture enthalpy is unchanged but temperature changes. Feed location cannot be found from  $T_F$  and  $z$  on the graph because equilibrium data is at a lower pressure on the graph used for this calculation.

2.A2. Yes.

2.A3. The liquid is superheated when the pressure drops, and the energy comes from the amount of superheat.

2.A4.

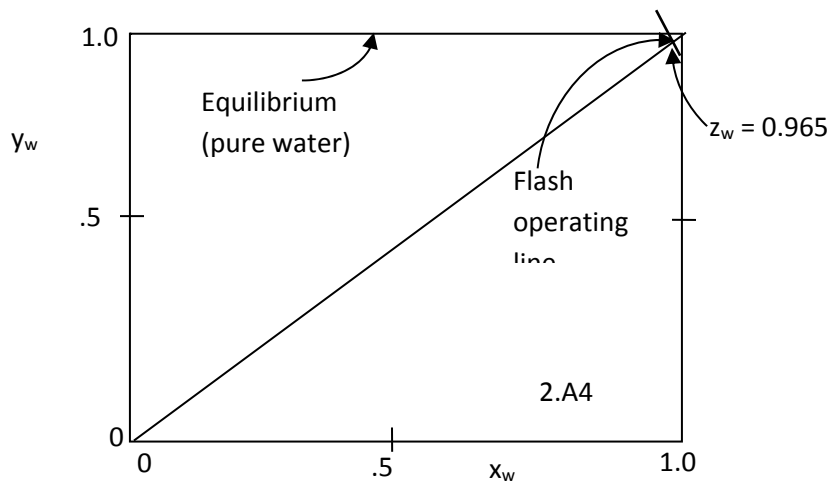

2.A6. In a flash drum separating a multicomponent mixture, raising the pressure will:

- i. Decrease the drum diameter and decrease the relative volatilities. *Answer is i.*

2.A8. *New Problem in 4<sup>th</sup> ed.*

- a. At 100°C and a pressure of 200 kPa what is the K value of n-hexane? 0.29  
 b. As the pressure increases, the K value  
 a. increases, b. decreases, c. stays constant b  
 c. Within a homologous series such as light hydrocarbons as the molecular weight increases, the K value (at constant pressure and temperature)  
 a. increases, b. decreases, c. stays constant b  
 d. At what pressure does pure propane boil at a temperature of -30°C? 160 kPa

- 2.A9. a. The answer is 3.5 to 3.6  
 b. The answer is 36°C  
 c. *This part is new in 4<sup>th</sup> ed.* 102°C
- 2.A10. *Parts c, d, and e are new in 4<sup>th</sup> ed.* a. 0.22; b. No; c. From y-x plot for Methanol  $x = 0.65$ ,  $y_M = 0.85$ ; thus,  $y_W = 0.15$ . d.  $K_M = 0.579/0.2 = 2.895$ ,  $K_W = (1 - 0.579)/(1 - 0.2) = 0.52625$ . e.  $\alpha_{M-W} = K_M/K_W = 2.895/0.52625 = 5.501$ .
- 2.A11. *New problem in 4<sup>th</sup> edition.* Because of the presence of air this is not a binary system. Also, it is not at equilibrium.
- 2.A12. *New problem in 4<sup>th</sup> edition.* The entire system design includes extensive variables and intensive variables necessary to solve mass and energy balances. Gibbs phase rule refers only to the intensive variables needed to set equilibrium conditions.
- 2.A13. *New problem in 4<sup>th</sup> edition.* Although V is an extensive variable, V/F is an intensive variable and thus satisfies Gibbs phase rule.
- 2.A14. *New problem in 4<sup>th</sup> edition.*  $1.0 \text{ kg/cm}^2 = 0.980665 \text{ bar} = 0.96784 \text{ atm}$ .  
 Source: <http://www.unit-conversion.info/pressure.html>
- 2.B1. Must be sure you don't violate Gibbs phase rule for intensive variables in equilibrium.  
 Examples:
- |   |   |                 |
|---|---|-----------------|
| F, z, $T_{\text{drum}}$ , $P_{\text{drum}}$               | F, $T_F$ , z, p                                     | F, $h_F$ , z, p |
| F, z, y, $P_{\text{drum}}$                                | F, $T_F$ , z, y                                     | F, $h_F$ , z, y |
| F, z, x, $P_{\text{drum}}$                                | F, $T_F$ , z, x                                     | etc.            |
| F, z, y, $P_{\text{drum}}$                                | F, $T_F$ , z, $T_{\text{drum}}$ , $P_{\text{drum}}$ |                 |
| F, z, x, $T_{\text{drum}}$                                | F, $T_F$ , y, p                                     |                 |
| Drum dimensions, z, $F_{\text{drum}}$ , $P_{\text{drum}}$ | F, $T_F$ , y, $T_{\text{drum}}$                     |                 |
| Drum dimensions, z, y, $P_{\text{drum}}$                  | F, $T_F$ , x, p                                     |                 |
| etc.  | F, $T_F$ , x, $T_{\text{drum}}$                     |                 |
|   | F, $T_F$ , y, x                                     |                 |
- 2.B2. This is essentially the same problem (disguised) as problem 2-D1c and e but with an existing (larger) drum and a higher flow rate.  
 With  $y = 0.58$ ,  $x = 0.20$ , and  $V/F = 0.25$  which corresponds to 2-D1c.  
 If  $F = 1000 \frac{\text{lb mole}}{\text{hr}}$ ,  $D = .98$  and  $L = 2.95 \text{ ft}$  from Problem 2-D1e .  
 Since  $D \propto \sqrt{V}$  and for constant V/F,  $V \propto F$ , we have  $D \propto \sqrt{F}$ .  
 With  $F = 25,000$ :  
 $\sqrt{F_{\text{new}}/F_{\text{old}}} = 5$ ,  $D_{\text{new}} = 5 D_{\text{old}} = 4.90$ , and  $L_{\text{new}} = 3 D_{\text{new}} = 14.7$ .  
 Existing drum is too small.

Feed rate drum can handle:  $F \propto D^2$ .  $\frac{F_{\text{existing}}}{1000} = \left(\frac{D_{\text{exist}}}{.98}\right)^2 = \left(\frac{4}{.98}\right)^2$  gives

$$F_{\text{existing}} = 16,660 \text{ lbmol/h}$$

*Alternatives*

- Do drums in parallel. Add a second drum which can handle remaining 8340 lbmol/h.
- Bypass with liquid mixing

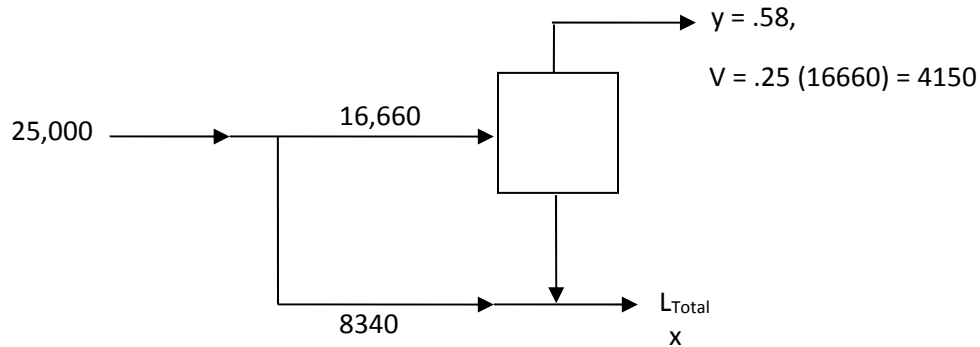

Since  $x$  is not specified, use bypass. This produces less vapor.

- Look at Eq. (2-62), which becomes

$$D = \sqrt{\frac{V(MW_v)}{3K_{\text{drum}} 3600 \sqrt{(\rho_L - \rho_v) \rho_v}}}$$

Bypass reduces  $V$

- $K_{\text{drum}}$  is already 0.35. Perhaps small improvements can be made with a better demister → Talk to the manufacturers.
- $\rho_v$  can be increased by increasing pressure. Thus operate at higher pressure. Note this will change the equilibrium data and raise temperature. Thus a complete new calculation needs to be done.
- Try bypass with vapor mixing.
- Other alternatives are possible.

2.C2. 
$$\frac{V}{F} = \left[ \frac{-z_A}{(K_B - 1)} - \frac{z_B}{(K_A - 1)} \right]$$

2.C5. a. Start with 
$$x_i = \frac{Fz_i}{L + VK_i} \text{ and let } V = F - L$$

$$x_i = \frac{Fz_i}{L + (F - L)K_i} \text{ or } x_i = \frac{z_i}{\frac{L}{F} + \left(1 - \frac{L}{F}\right)K_i}$$

$$\text{Then } y_i = K_i x_i = \frac{K_i z_i}{\frac{L}{F} + \left(1 - \frac{L}{F}\right) K_i}$$

$$\text{From } \sum y_i - \sum x_i = 0 \text{ we obtain } \sum \frac{(K_i - 1) z_i}{\frac{L}{F} + \left(1 - \frac{L}{F}\right) K_i} = 0$$

2.C4. *New Problem.* Prove that the intersection of the operating and  $y = x$  lines for binary flash distillation occurs at the mole fraction of the feed.

SOLUTION:  $y = \frac{L}{V} y + \frac{F}{V} z$ , rearrange:  $y \left[1 + \frac{L}{V}\right] = \frac{F}{V} z$ , or  $y \left[\frac{V+L}{V}\right] = \frac{F}{V} z$  since  $V + L = F$ , the result is  $y = z$  and therefore  $x = y = z$  (2-18)

The intersection is at the feed composition.

2.C7. 
$$\sum \frac{z_i}{1 + (K_i - 1) \frac{V}{F}} - 1 = f\left(\frac{V}{F}\right)$$
 From data in Example 2-2 obtain:

V/F	0	.1	.2	.3	.4	.5	.6	.7	.8	.9	1.0
f	0	-.09	-.1	-.09	-.06	-.007	.07	.16	.3	.49	.77

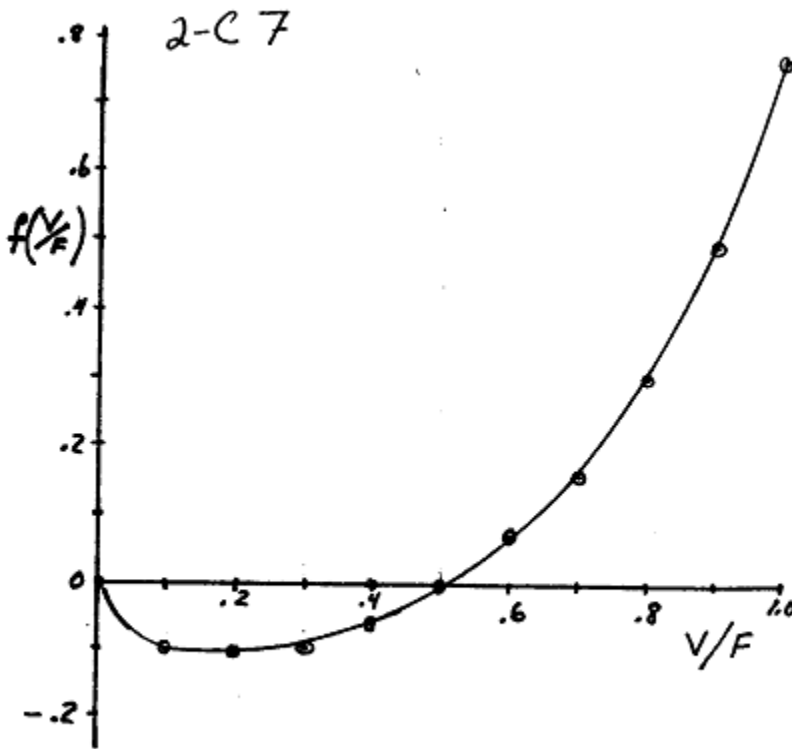

2.C8. Derivation of Eqs. (2-62) and (2-63). Overall and component mass balances are,

$$F = V + L_1 + L_2 \quad \text{and} \quad Fz_i = L_1x_{i,L1} + L_2 + x_{i,L2} + Vy_i \quad \text{Substituting in Eqs. (2-60b) and 2-60c)}$$

$$Fz_i = L_1K_{i,L1-L2}x_{i,L2} + L_2x_{i,L2} + VK_{i,V-L2}x_{i,L2}$$

Solving,

$$x_{i,L2} = \frac{Fz_i}{L_1K_{i,L2} + L_2 + VK_{i,V-L2}} = \frac{Fz_i}{L_1K_{i,L1-L2} + F - V - L_1 + VK_{i,V-L2}}$$

Dividing numerator and denominator by F and collecting terms.

$$x_{i,liq2} = \frac{z_i}{1 + (K_{i,L1-L2} - 1)\frac{L_1}{F} + (K_{i,V-L2} - 1)\frac{V}{F}}$$

Since  $y_i = K_{i,V-L2}x_{i,L2}$ ,  $y_i = \frac{K_{i,V-L2}z_i}{1 + (K_{i,L1-L2} - 1)\frac{L_1}{F} + (K_{i,V-L2} - 1)\frac{V}{F}}$

Stoichiometric equations,  $\sum_{i=1}^C x_{i,L2} = 1$ ,  $\sum_{i=1}^C y_i = 1$ , thus,  $\sum_{i=1}^C y_i - \sum_{i=1}^C x_{i,L2} = 0$

which becomes 
$$\sum_{i=1}^C \frac{(K_{i,V-L2} - 1)z_i}{\left[1 + (K_{i,L1-L2} - 1)\frac{L_1}{F} + (K_{i,V-L2} - 1)\frac{V}{F}\right]} = 0 \quad (2-62)$$

Since  $x_{i,liq1} = K_{i,L1-L2}x_{i,liq2}$ , we have  $x_{i,liq1} = \frac{K_{i,L1-L2}z_i}{1 + (K_{i,L1-L2} - 1)\frac{L_1}{F} + (K_{i,V-L2} - 1)\frac{V}{F}}$

In addition, 
$$\sum x_{i,liq1} - \sum x_{i,liq2} = 0 = \sum_{i=1}^C \frac{(K_{i,L1-L2} - 1)z_i}{\left[1 + (K_{i,L1-L2} - 1)\frac{L_1}{F} + (K_{i,V-L2} - 1)\frac{V}{F}\right]} \quad (2-63)$$

2.D1.

a.  $V = (0.4)100 = 40$  and  $L = F - V = 60$  kmol/h

Slope op. line  $= -L/V = -3/2$ ,  $y = x = z = 0.6$

See graph.  $y = 0.77$  and  $x = 0.48$

b.  $V = (0.4)(1500) = 600$  and  $L = 900$ . Rest same as part a.

c. Plot  $x = 0.2$  on equil. Diagram and  $y = x = z = 0.3$ .  $y_{\text{intercept}} = zF/V = 1.2$

$V/F = z/1.2 = 0.25$ . From equil  $y = 0.58$ .

d. Plot  $x = 0.45$  on equilibrium curve.

$$\text{Slope} = -\frac{L}{V} = -\frac{F-V}{V} = -\frac{1-V/F}{V/F} = \frac{-.8}{.2} = -4$$

Plot operating line,  $y = x = z$  at  $z = 0.51$ . From mass balance  $F = 37.5$  kmol/h.

e. Find Liquid Density.

$$\overline{MW}_L = x_m (MW_m) + x_w (MW_w) = (.2)(32.04) + (.8)(18.01) = 20.82$$

$$\text{Then, } \bar{V}_L = x_m \frac{MW_m}{\rho_m} + x_w \frac{MW_w}{\rho_w} = .2 \left( \frac{32.04}{.7914} \right) + .8 \left( \frac{18.01}{1.00} \right) = 22.51 \text{ ml/mol}$$

$$\rho_L = \overline{MW}_L / \bar{V}_L = 20.82 / 22.51 = 0.925 \text{ g/ml}$$

Vapor Density:  $\rho_v = p(MW)_{v,avg} / RT$  (Need temperature of the drum)

$$\overline{MW}_v = y_m (MW)_m + y_w (MW)_w = .58(32.04) + .42(18.01) = 26.15 \text{ g/mol}$$

Find Temperature of the Drum  $T$ : From Table 3-3 find  $T$  when

$$y = .58, x = 20, T = 81.7^\circ\text{C} = 354.7\text{K}$$

$$\rho_v = (1 \text{ atm})(26.15 \text{ g/mol}) / \left[ \left( 82.0575 \frac{\text{ml atm}}{\text{mol } ^\circ\text{K}} \right) (354.7 \text{ K}) \right] = 8.98 \times 10^{-4} \text{ g/ml}$$

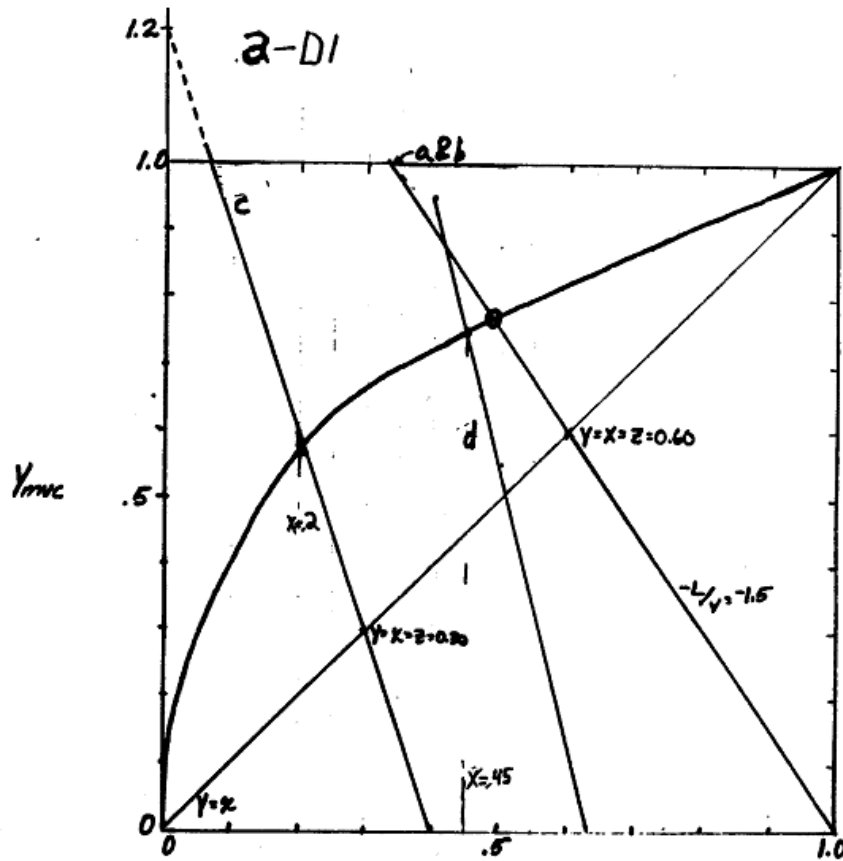

Find Permissible velocity:

$$u_{perm} = K_{drum} \sqrt{(\rho_L - \rho_v) / \rho_v}, K_{drum} = \exp \left[ A + B(\ln F_{iv}) + C(\ln F_{iv})^2 + D(\ln F_{iv})^3 + E(\ln F_{iv})^4 \right] \quad 2-60$$

$$V = \left( \frac{V}{F} \right) F = (0.25)1000 = 250 \text{ lbmol/h}, W_v = V(\overline{MW}_v) = 250 \left( 26.15 \frac{\text{lb}}{\text{lbmol}} \right) = 6537.5 \text{ lb/h}$$

$$L = F - V = 1000 - 250 = 750 \text{ lbmol/h}, \text{ and } W_L = (L)(\overline{MW}_L) = (750)(20.82) = 15,615 \text{ lb/h},$$

$$F_{lv} = \frac{W_L}{W_V} \sqrt{\frac{\rho_V}{\rho_L}} = \left( \frac{15615}{6537.5} \right) \sqrt{\frac{8.89 \times 10^{-4}}{.925}} = 0.0744, \text{ and } \ln(F_{lv}) = -2.598$$

Then  $K_{\text{drum}} = .442$ , and  $u_{\text{perm}} = .442 \sqrt{\frac{.925 - 8.98 \times 10^{-4}}{8.98 \times 10^{-4}}} = 14.19 \text{ ft/s}$

$$A_{cs} = \frac{V(\overline{MW}_v)}{u_{\text{perm}} 3600 \rho_v} = \frac{250(26.15)(454 \text{ g/lb})}{(14.19)(3600)(8.98 \times 10^{-4} \text{ g/ml})(28316.85 \text{ ml/ft}^3)} = 2.28 \text{ ft}^2.$$

$D = \sqrt{4A_{cs}/\pi} = 1.705 \text{ ft}$ . Use 2 ft diameter. L ranges from  $3 \times D = 6 \text{ ft}$  to  $5 \times D = 10 \text{ ft}$

Note that this design is conservative if a demister is used.

- f. Plot T vs x from Table 3-3. When  $T = 77^\circ\text{C}$ ,  $x = 0.34$ ,  $y = 0.69$ . This problem is now very similar to 3-D1c. Can calculate V/F from mass balance,  $Fz = Lx + Vy$ . This is

$$Fz = (F - V)x + Vy \text{ or } \frac{V}{F} = \frac{z - y}{y - x} = \frac{0.4 - 0.34}{0.69 - 0.34} = 0.17$$

- g. Part g is a new problem.  $V = 16.18 \text{ mol/h}$ ,  $L = 33.82$ ,  $y = 0.892$ ,  $x = 0.756$ .

- 2-D2. Work backwards. Starting with  $x_2$ , find  $y_2 = 0.62$  from equilibrium. From equilibrium point plot op. line of slope  $= -(L/V)_2 = -\left(1 - \frac{V}{F}\right)_2 / (V/F)_2 = -3/7$ . Find  $z_2 = 0.51 = x_1$  (see

Figure). From equilibrium,  $y_1 = 0.78$ . For stage 1,  $\frac{V}{F} = \frac{z_1 - x_1}{y_1 - x_1} = \frac{0.55 - 0.51}{0.78 - 0.51} = 0.148$ .

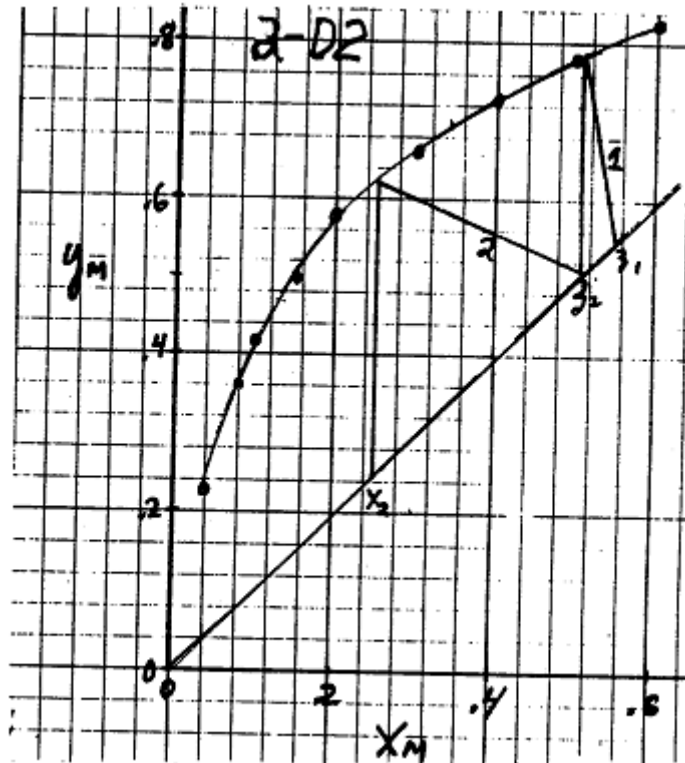

2.D3. *New Problem in 4<sup>th</sup> edition.. Part a.*

x ethane	T °C	y ethane
0	63.19	0
.025	56.18	0.1610
.05	49.57	0.2970
.10	37.57	0.5060
.15	27.17	0.6503
.20	18.26	0.7492
.25	10.64	0.8175
.30	4.11	0.8652
1.0	-37.47	1.0

**b.** See Figure. a. If 1 bubble of vapor product ( $V/F = 0$ ) vapor product, vapor  $y_E = 0.7492$  (highest) liquid  $x_E = z_E = 0.20$  (highest) and  $T = 18.26$  °C. If 1 drop of liquid product ( $V/F = 1$ )  $y_E = z_E = 0.20$  (lowest),  $x_E = 0.035$ ,  $T$  (by linear interpolation)  $\sim 56.18 + [(49.57 - 56.18)/(0.297 - 0.161)][.2 - 0.16] = 54.2$  °C (highest).

**c.** See figure. Slope =  $-L/V = -(1 - V/F)/(V/F) = -.6/.4 = -1.5$ .  $x_E = 0.12$ ,  $y_E = 0.57$ ,  $T = 33.4$ °C.

**d.** From equilibrium data  $y_E = 0.7492$ . For an  $F = 1$ ,  $L = 1 - V$ , Ethane balance:  $.2L = 1(.3) - 0.7492 V$ . Solve 2 equations:  $V/F = 0.1821$ . Can also find  $V/F$  from slope of operating line.

**e.** If do linear interpolation on equilibrium data,  $x = 0.05 + (45-49.57)(0.1 - 0.05)/(37.57 - 49.57) = 0.069$ . From equilibrium plot  $y = 0.375$ .

Mass balance for basis  $F = 1$ ,  $L = 1 - V$  and  $0.069 L = 0.18 - 0.375 V$ . Solve simultaneously,  $V/F = 0.363$ .

2.D4. *New problem in 3<sup>rd</sup> edition.* Highest temperature is dew point ( $V/F = 0$ )

Set  $z_i = y_i$ .  $K_i = y_i/x_i$ . Want  $\sum x_i = \sum y_i/K_i = 1.0$

$$K_{\text{ref}}(T_{\text{New}}) = K_{\text{ref}}(T_{\text{Old}}) \left( \sum (y_i/K_i) \right)$$

If pick C4 as reference: First guess  $K_{\text{butane}} = 1.0$ ,  $T = 41$ °C:  $K_{C_3} = 3.1$ ,  $K_{C_6} = 0.125$

$$\sum \frac{y_i}{K_i} = \frac{.2}{3.1} + \frac{.35}{1.0} + \frac{.45}{.125} = 4.0145 \quad T \text{ too low}$$

Guess for reference:  $K_{C_4} = 4.014$ ,  $T = 118$ °C:  $K_{C_3} = 8.8$ ,  $K_{C_6} = .9$

$$\sum \frac{y_i}{K_i} = \frac{.2}{8.8} + \frac{.35}{4.0145} + \frac{.45}{.9} = 0.6099$$

$$K_{C_4, \text{NEW}} = 4.0145(.6099) = 2.45, T = 85: K_{C_2} = 6.0, K_{C_6} = 0.44$$

$$\sum \frac{y_i}{K_i} = \frac{.2}{6} + \frac{.35}{2.45} + \frac{.45}{.44} = 1.20$$

$$K_{C4,NEW} = 2.45 \times 1.2 = 2.94, T = 96^\circ\text{C}: K_{C3} = 6.9, K_{C6} = 0.56$$

$$\sum \frac{y_i}{K_i} = \frac{.2}{6.9} + \frac{.35}{2.94} + \frac{.45}{.56} = 0.804 \Rightarrow \text{Gives } 84^\circ\text{C}$$

Use  $90.5^\circ \rightarrow$  Avg last two T  $K_{C4} = 2.7, K_{C3} = 6.5, K_{C6} = 0.49$

$$\sum (y_i/K_i) = \frac{.2}{6.5} + \frac{.35}{2.7} + \frac{.45}{.49} = 1.079, T \sim 87-88^\circ\text{C}$$

Note: hexane probably better choice as reference.

2.D5. a)

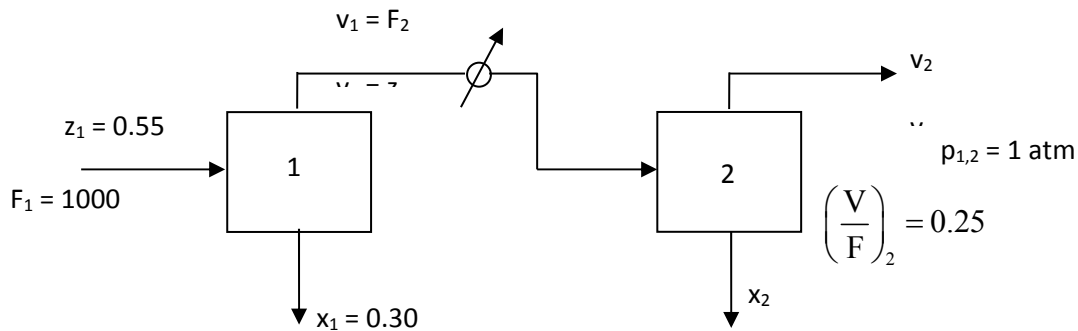

b)  $y_1 = -\frac{L}{V_1}x_1 + \frac{F}{V_1}z$  Plot 1<sup>st</sup> Op line.

$$y_1 = 0.66 = z_2$$

$y = x = z = 0.55$  to  $x_1 = 0.3$  on eq. curve (see graph)

$$\text{Slope} = -\frac{L}{V_1} = \frac{0.55 - 0.80}{.55 - 0} = -\frac{.25}{.55} = -0.454545 \quad L_1 + V_1 = F_1 = 1000$$

$$V_1 = 687.5 \text{ kmol/h} = F_2$$

$$\left(\frac{V}{F}\right)_1 = \frac{687.5}{1000} = 0.6875$$

c) Stage 2  $= \frac{V}{F} = 0.25, -\frac{L}{V} = \frac{-0.75F}{0.25F} = -3, y = x = z_2 = 0.66$ . Plot op line

$$\text{At } x = 0, y = z / (V/F) = \frac{0.66}{0.25} = 2.64. \text{ At } y = 0, x_2 = \frac{F}{L}z = \frac{z}{L/F} = \frac{0.66}{0.75} = 0.88$$

From graph  $y_2 = 0.82, x_2 = 0.63$ .  $V_2 = \left(\frac{V}{F}\right)_2 F_2 = (0.25)687.5 = 171.875 \text{ kmol/h}$

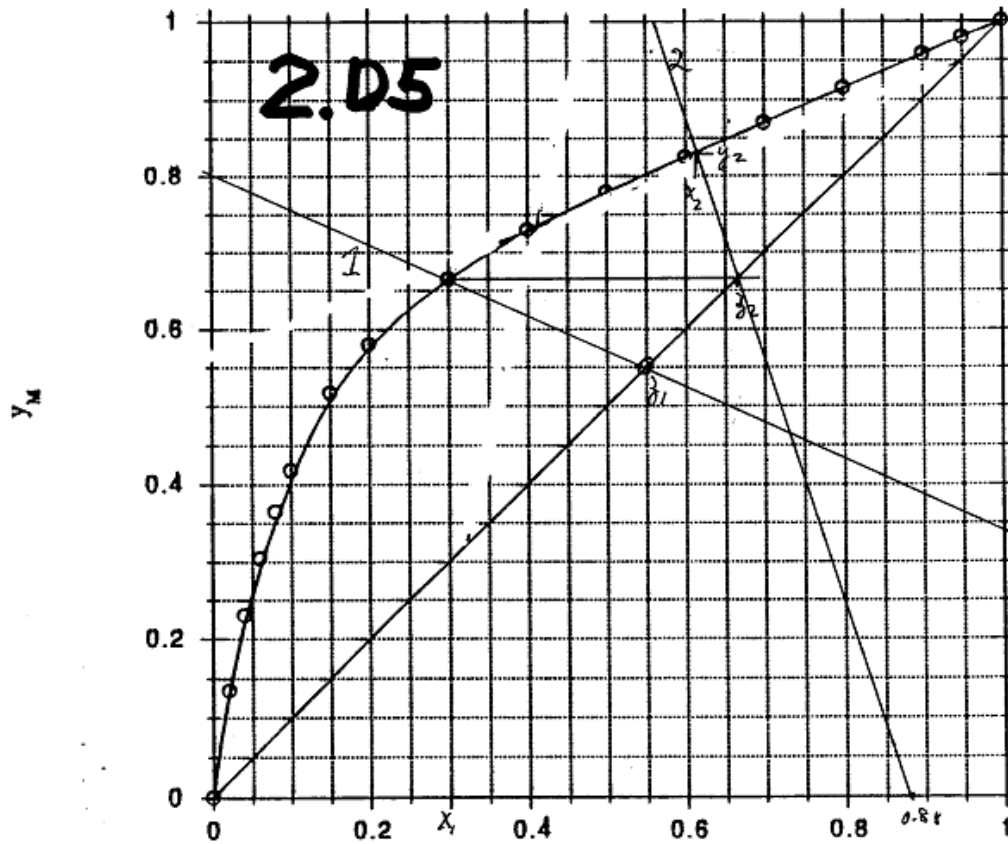

2.D6. *New problem in 4<sup>th</sup> ed. a.)* The answer is  $VP = \underline{19.30}$  mm Hg

$$\log_{10}(VP) = 6.8379 - \frac{1310.62}{100 + 136.05} = 1.2856$$

b.) The answer is  $K = \underline{0.01693}$ .  $K = \frac{VP}{P_{\text{tot}}} = \frac{19.30}{1.5(760)}$

2.D7. *New problem 4<sup>th</sup> ed.*

Part a. Drum 1:  $V_1/F_1 = 0.3$ , Slope op line =  $-L/V = -7/3 = -7/3$ ,  $y=x=z_1=0.46$ .  $L_1 = F_2 = 70$ .

From graph  $x_1 = z_2 = 0.395$

Drum 2:  $V_1/F_1 = 30/70$ , Slope op line =  $-L/V = -7/3$ ,  $y=x=z_2=0.395$ .  $L_1 = F_2 - V_2 = 40$ .

From graph  $x_2 = 0.263$

Part b. Single drum:  $V/F = 0.6$ , Slope op line =  $-L/V = -40/60 = -2/3$ , From graph  $x = 0.295$ .

More separation with 2 drums.



$$\text{Avg. MW} = \frac{100}{4.536} = 22.046 \quad \text{Mole fracs: } x_E = \frac{0.6512}{4.536} = 0.1435, x_w = 0.8565.$$

Use  $C_{P_{\text{EtOH}}}$  at  $100^\circ\text{C}$  as an average  $C_p$  value.

$$\bar{C}_{P_L} = 37.96(.1435) + 18.0(.8565) = 20.86 \frac{\text{kcal}}{\text{kmol } ^\circ\text{C}}$$

$$\text{Per kg this is } \frac{\bar{C}_{P_L}}{\text{MW}_{\text{avg}}} = \frac{20.86}{22.046} = 0.946 \frac{\text{kcal}}{\text{kg } ^\circ\text{C}}$$

$$h_F = 0.946(2000) = 189.2 \text{ kcal/kg}$$

which can now be plotted on the enthalpy composition diagram.

Obtain  $T_{\text{drum}} \approx 88.2^\circ\text{C}$ ,  $x_E = 0.146$ , and  $y_E = 0.617$ .

For  $F = 1000$  find  $L$  and  $V$  from  $F = L + V$  and  $Fz = Lx + Vy$  which gives  $V = 326.9$ , and  $L = 673.1$

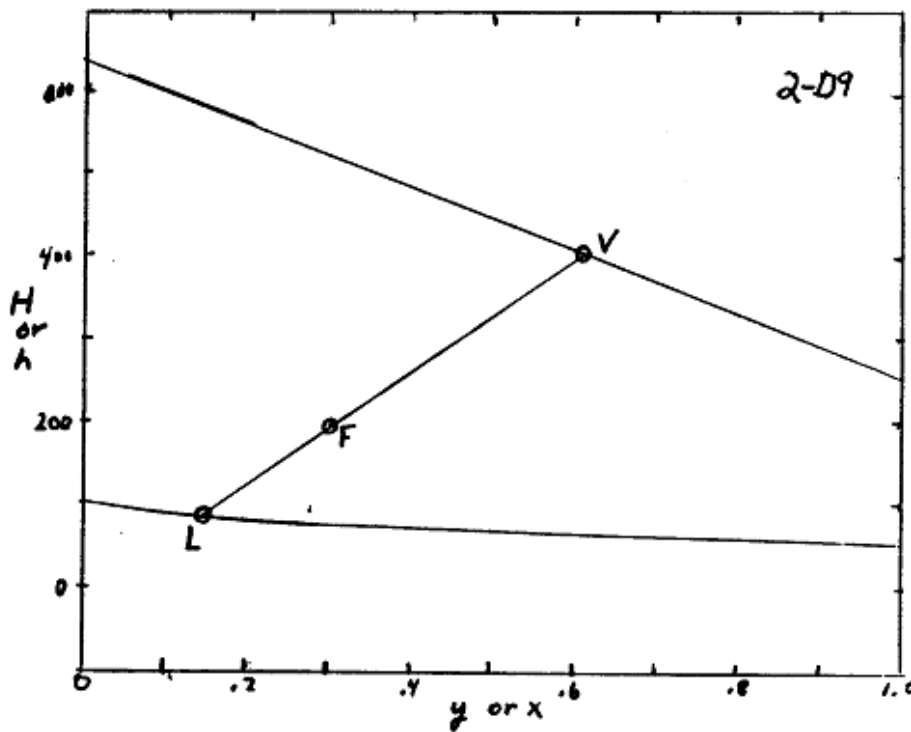

Note: If use wt. fracs.  $\bar{C}_{P_L} = 23.99$  &  $\bar{C}_{P_L}/\text{MW}_{\text{avg}} = 1.088$  and  $h_F = 217.6$ . All wrong.

2.D.10 Solution 400 kPa,  $70^\circ\text{C}$

$z_{C_4} = 35$  Mole % n-butane  $x_{C_6} = 0.7$

From DePriester chart

$K_{C_3} = 5$ ,  $K_{C_4} = 1.9$ ,  $K_{C_6} = 0.3$

$$\text{Know } y_i = K_i x_i, \quad x_i = \frac{z_i}{1 + (K_i - 1) \frac{V}{F}}, \quad \sum x_i = \sum y_i = 1 = \sum z_i$$

$$\text{R.R.} \quad \sum \frac{(K_i - 1)z_i}{1 + (K_i - 1)\frac{V}{F}} = 0 \quad z_{C3} = 1 - z_{C6} - z_{C4} = .65 - z_{C6}$$

$$\text{C6: } 0.7 = \frac{z_{C6}}{1 + (K_{C6} - 1)\frac{V}{F}} = \frac{z_{C6}}{1 - 0.7\frac{V}{F}} \Rightarrow z_{C6} = 0.7 \left( 1 - 0.7\frac{V}{F} \right), \quad z_{C6} = 0.7 - 0.49\frac{V}{F}$$

$$\text{RR Eq:} \quad \frac{4(.65 - z_{C6})}{1 + 4\frac{V}{F}} + \frac{0.9(.35)}{1 + 0.9\frac{V}{F}} - \frac{0.7z_{C6}}{1 - 0.7\frac{V}{F}} = 0$$

2 equations & 2 unknowns. Substitute in for  $z_{C6}$ . Do in Spreadsheet. Use Goal – Seek to find  $V/F$ .  $V/F = 0.594$  when R.R. equation = 0.000881.

$$z_{C6} = 0.7 - 0.49\frac{V}{F} = 0.7 - (0.49)(0.594) = 0.40894$$

2.D11. *New Problem 4<sup>th</sup> ed.* Obtain  $K_{\text{ethylene}} = 2.2$ ,  $K_{\text{propylene}} = 0.56$  from De Priester chart.

$$K_E = y_E/x_E \text{ and } K_P = y_P/x_P \text{ Since } y_P = 1 - y_E \text{ and } x_P = 1 - x_E, \quad K_P = (1 - y_E)/(1 - x_E).$$

Thus, 2 eqs and 2 unknowns. Solve for  $y_E$  and  $x_E$ .

$$x_E = (1 - K_P) / (K_E - K_P) \text{ and } y_E = K_E x_E = K_E (1 - K_P) / (K_E - K_P)$$

$$x_E = (1 - 0.56) / (2.2 - 0.56) = 0.268 \text{ and } y_E = K_E x_E = (2.2)(0.268) = 0.590$$

$$\text{Check: } x_P = 1 - x_E = 1 - 0.268 = 0.732 \text{ and } y_P = 1 - y_E = 1 - 0.590 = 0.410$$

$$K_P = y_P/x_P = 0.410/0.732 = 0.56 \text{ OK}$$

2.D12. For problem 2.D1c, plot  $x = 0.2$  on equilibrium diagram with feed composition of 0.3. The resulting operating line has a  $y$  intercept =  $z/(V/F) = 1.2$ . Thus  $V/F = 0.25$  (see figure in Solution to 2.D1) Vapor mole fraction is  $y = 0.58$ .

*Find Liquid Density.*

$$\overline{MW}_L = x_m (MW_m) + x_w (MW_w) = (.2)(32.04) + (.8)(18.01) = 20.82$$

$$\text{Then, } \bar{V}_L = x_m \frac{MW_m}{\rho_m} + x_w \frac{MW_w}{\rho_w} = .2 \left( \frac{32.04}{.7914} \right) + .8 \left( \frac{18.01}{1.00} \right) = 22.51 \text{ ml/mol}$$

$$\rho_L = \overline{MW}_L / \bar{V}_L = 20.82/22.51 = 0.925 \text{ g/ml}$$

$$\text{Find Vapor Density. } \rho_v = \frac{p(\overline{MW})_v}{RT} \text{ (Need temperature of the drum)}$$

$$\overline{MW}_v = y_m (MW)_m + y_w (MW)_w = .58(32.04) + .42(18.01) = 26.15 \text{ g/mol}$$

*Find Temperature of the Drum T:*

From Table 2-7 find  $T$  corresponding to  $y = .58, x = .20, T = 81.7^\circ\text{C} = 354.7\text{K}$

$$\rho_v = (1 \text{ atm})(26.15 \text{ g/mol}) / \left[ \left( 82.0575 \frac{\text{ml atm}}{\text{mol } ^\circ\text{K}} \right) (354.7 \text{ K}) \right] = 8.98 \cdot 10^{-4} \text{ g/ml}$$

$$\text{Find Permissible velocity: } u_{\text{perm}} = K_{\text{drum}} \sqrt{(\rho_L - \rho_v) / \rho_v}$$

$$K_{\text{drum, horizontal}} = 1.25 \times K_{\text{drum, vertical}} = \left\{ \exp \left[ A + B(\ln F_{iv}) + C(\ln F_{iv})^2 + D(\ln F_{iv})^3 + E(\ln F_{iv})^4 \right] \right\} \times 1.25$$

$$\text{Since } V = (V/F) = (0.25)1000 = 250 \text{ lbmol/h,}$$

$$W_v = V(\overline{MW}_v) = 250(26.15 \text{ lb/lbmol}) = 6537.5 \text{ lb/h}$$

$$L = F - V = 1000 - 250 = 750 \text{ lbmol/h, and } W_L = (L)(\overline{MW}_L) = (750)(20.82) = 15,615 \text{ lb/h,}$$

$$F_{iv} = \frac{W_L}{W_v} \sqrt{\frac{\rho_v}{\rho_L}} = \left( \frac{15615}{6537.5} \right) \sqrt{\frac{8.98 \times 10^{-4}}{.925}} = 0.0744, \text{ and } \ln(F_{iv}) = -2.598$$

$$K_{\text{drum, vertical}} = 0.442, \text{ and } K_{\text{drum, horiz}} = 0.5525$$

$$u_{\text{perm}} = 0.5525 \sqrt{\frac{0.925 - 8.98 \times 10^{-4}}{8.98 \times 10^{-4}}} = 17.74 \text{ ft/s}$$

$$A_{cs} = \frac{V(\overline{MW}_v)}{u_{\text{perm}} 3600 \rho_v} = \frac{250(26.15)(454 \text{ g/lbm})}{(17.74)(3600)(8.98 \times 10^{-4} \text{ g/ml})(28316.85 \text{ ml/ft}^3)}$$

$$A_{Cs} = 1.824 \text{ ft}^2, \quad A_T = A_{Cs}/0.2 = 9.12 \text{ ft}^2$$

$$\text{With } L/D = 4, \quad D = \sqrt{4A_T/\pi} = 3.41 \text{ ft and } L = 13.6 \text{ ft}$$

2.D13. *New Problem 4<sup>th</sup> ed.*  $x_{\text{butane}} = 1 - x_E = 0.912$ ,  $y_{\text{butane}} = 1 - y_E = 0.454$ .  $K_E = y_E/x_E = 0.546/0.088 = 6.20$ ,  $K_{\text{butane}} = y_B/x_B = 0.454/0.912 = 0.498$ .

Plot  $K_E$  and  $K_{\text{butane}}$  on DePriester chart. Draw straight line between them. Intersections with T and P axis give  $T_{\text{drum}} = 15 \text{ }^\circ\text{C}$ , and  $p_{\text{drum}} = 385 \text{ kPa}$  from Figure 2-12.

Use mass balances to find V/F:  $F = L + V$  and  $Fz_E = Lx_E + Vy_E$ . Substitute  $L = F - V$  into ethane balance and divide both sides by F. Obtain:  $z = (1 - V/F)x + y(V/F)$ .

Solve for  $V/F = (z-x)/(y-x) = (0.36 - 0.088)/(0.546 - 0.088) = 0.594$ .

Spreadsheet used as a check (using  $T=15$  and  $p = 385$ ) gave  $V/F = 0.593$ .

2.D14. *New Problem 4<sup>th</sup> ed.* DePriester chart, Fig. 2-12:  $K_{C1} = 50$ ,  $K_{C4} = 1.1$ , and  $K_{C5} = 0.37$ ;  $z_1 = 0.12$ ,  $z_4 = 0.48$ ,  $z_5 = 0.40$

$$\text{Rachford-Rice equation: } \frac{(K_{C2} - 1)z_{C1}}{1 + (K_{C1} - 1)\frac{V}{F}} + \frac{(K_{iC4} - 1)z_{nC4}}{1 + (K_{nC4} - 1)\frac{V}{F}} + \frac{(K_{nC4} - 1)z_{nC5}}{1 + (K_{nC5} - 1)\frac{V}{F}} = 0$$

$$\text{Equation becomes: } \frac{5.88}{1 + 49(V/F)} + \frac{0.048}{1 + 0.1(V/F)} - \frac{0.252}{1 - 0.63(V/F)} = 0$$

Trials:  $V/F = 0.4$ , Eq. = -0.005345;  $V/F = 0.39$ , Eq. = 0.004506;  $V/F = 0.394$ , Eq. = 0.000546, which is close enough with DePriester chart.

Liquid mole fractions:

$$x_{C1} = \frac{z_{C1}}{1 - (K_{C1} - 1)(V/F)} = \frac{.12}{1 + 49(.394)} = 0.00591; \quad x_{C4} = 0.4618, \quad x_{C5} = 0.5321, \text{ and } \sum x_i = 0.9998$$

Vapor mole fractions:  $y_i = K_i x_i$ ;  $y_{C1} = 50(0.00591) = 0.2955$ ,  $y_{C4} = 0.5080$ ,  $y_{C5} = 0.1969$ ,  $\sum y_i = 1.0004$ .

- 2.D15. This is an unusual way of stating problem. However, if we count specified variables we see that problem is not over or under specified. Usually V/F would be the variable, but here it isn't. We can still write R-R eqn. Will have three variables:  $z_{C2}$ ,  $z_{iC4}$ ,  $z_{nC4}$ . Need two other eqns:  $z_{iC4}/z_{nC4} = \text{constant}$ , and  $z_{C2} + z_{iC4} + z_{nC4} = 1.0$   
Thus, solve three equations and three unknowns simultaneously.

*Do It.* Rachford-Rice equation is,

$$\frac{(K_{C2} - 1)z_{C2}}{1 + (K_{C2} - 1)\frac{V}{F}} + \frac{(K_{iC4} - 1)z_{iC4}}{1 + (K_{iC4} - 1)\frac{V}{F}} + \frac{(K_{nC4} - 1)z_{nC4}}{1 + (K_{nC4} - 1)\frac{V}{F}} = 0$$

Can solve for  $z_{C2} = 1 - z_{iC4}$  and  $z_{iC4} = (.8) z_{nC4}$ . Thus  $z_{C2} = 1 - 1.8 z_{nC4}$

Substitute for  $z_{iC4}$  and  $z_{C2}$  into R-R eqn.

$$\frac{(K_{C2} - 1)}{1 + (K_{C2} - 1)\frac{V}{F}}(1 - 1.8 z_{nC4}) + \frac{.8(K_{iC4} - 1)}{1 + (K_{iC4} - 1)\frac{V}{F}}z_{nC4} + z_{nC4} \frac{(K_{nC4} - 1)}{1 + (K_{nC4} - 1)\frac{V}{F}} = 0$$

$$\text{Thus, } z_{nC4} = \frac{\frac{(K_{C2} - 1)}{1 + (K_{C2} - 1)\frac{V}{F}}}{1.8 \frac{(K_{C2} - 1)}{1 + (K_{C2} - 1)\frac{V}{F}} - \frac{.8(K_{iC4} - 1)}{1 + (K_{iC4} - 1)\frac{V}{F}} - \frac{(K_{nC4} - 1)}{1 + (K_{nC4} - 1)\frac{V}{F}}}$$

Can now find K values and plug away.  $K_{C2} = 2.92$ ,  $K_{iC4} = .375$ ,  $K_{nC4} = .26$ .

Solution is  $z_{nC4} = 0.2957$ ,  $z_{iC4} = .8 (.2957) = 0.2366$ , and  $z_{C2} = 0.4677$

- 2.D16.  $z_{C1} = 0.5$ ,  $z_{C4} = 0.1$ ,  $z_{C5} = 0.15$ ,  $z_{C6} = 0.25$ ,  $K_{C1} = 50$ ,  $K_{C4} = .6$ ,  $K_{C5} = .17$ ,  $K_{C6} = 0.05$   
1<sup>st</sup> guess. Can assume all C<sub>1</sub> in vapor, ~ 1/3 C<sub>4</sub> in vapor, C<sub>5</sub> & C<sub>6</sub> in bottom

$$(V/F)_1 = .5 + (.1)/3 = .53 \quad \text{This first guess is not critical.}$$

$$\text{R.R. eq. } f\left(\frac{V}{F}\right) = \sum \frac{(K_i - 1)z_i}{1 + (K_i - 1)V/F} = 0$$

$$\frac{49(.5)}{1 + 49(.53)} + \frac{(-.4)(.1)}{1 - .4(.53)} + \frac{(-.83)(.15)}{1 - .83(.53)} + \frac{(-.95)(.25)}{1 - .95(.53)} = 0.157$$

$$\text{Eq. 3.33 } \left(\frac{V}{F}\right)_2 = \left(\frac{V}{F}\right)_1 + \frac{f(V/F)_1}{\sum \frac{z_i (K_i - 1)^2}{\left[1 - (K_i - 1)\frac{V}{F}\right]^2}}$$

where  $(V/F)_1 = 0.53$  and  $f(V/F)_1 = 0.157$ .

calculate  $(V/F)_2 = .53 + 0.157/2.92 = 0.584$

$$V = .584(150) = 87.6 \text{ kmol/h and } L = 150 - 87.6 = 62.4$$

$$x_{C1} = \frac{z_{C1}}{1 - (K_{C1} - 1)(V/F)} = \frac{.5}{1 + 49(.584)} = 0.016883$$

$$y_{C1} = K_{C1} x_{C1} = 50(0.016883) = 0.844$$

Similar for other components.

- 2-D17. a.  $V = 0.4F = 400$ ,  $L = 600$  Slope  $= -L/F = -1.5$   
 Intercepts  $y = x = z = 0.70$ . Plot line and find  $x_A = 0.65$ ,  $y_A = 0.77$  (see graph)  
 b.  $V = 2000$ ,  $L = 3000$ . Rest identical to part a.  
 c. Lowest  $x_A$  is horizontal op line ( $L = 0$ ).  $x_A = 0.12$   
 Highest  $y_A$  is vertical op line ( $V = 0$ ).  $y_A = 0.52$ . See graph

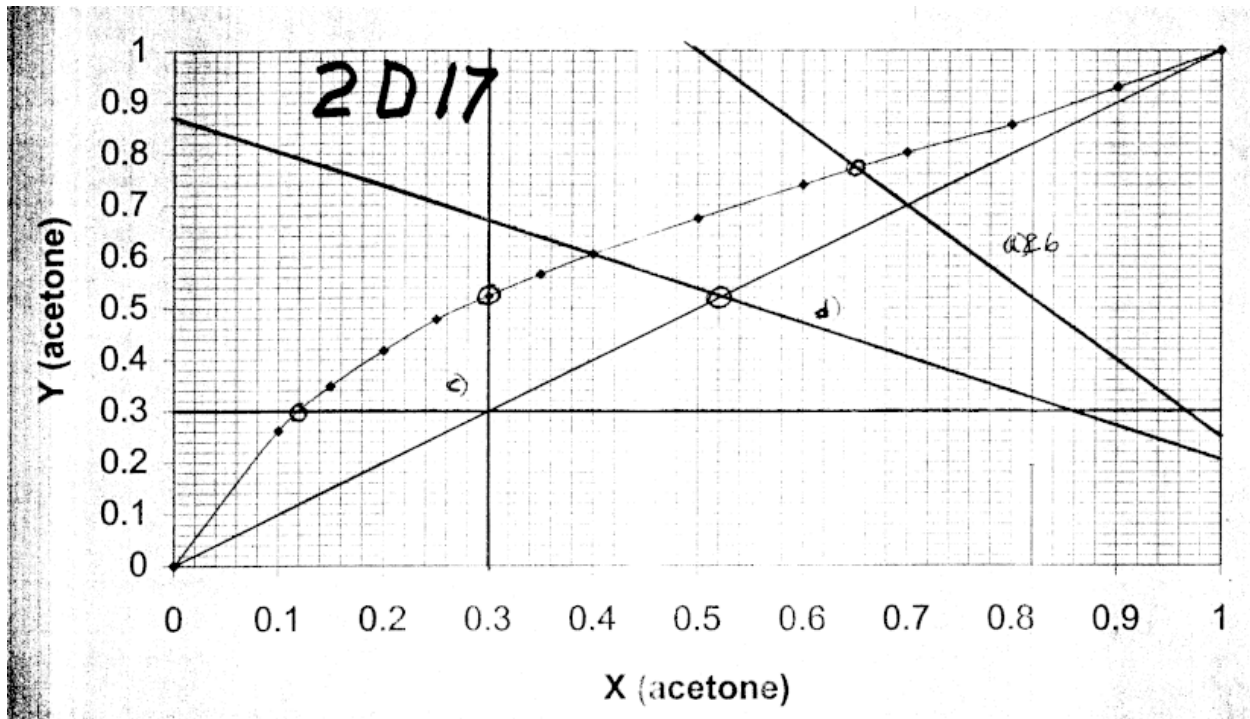

- d.  $V = 600$ ,  $L = 400$ ,  $-L/V = -0.667$ .  
 Find  $x_A = 0.40$  on equilibrium curve. Plot op line & find intersection point with  $y = x$  line.  $z_A = 0.52$

2.D18. From  $x_i = \frac{z_i}{1 + (K_i - 1)\frac{V}{F}}$ , we obtain  $\frac{V}{F} = \frac{\frac{z_h}{K_h} - 1}{K_h - 1}$

Guess  $T_{\text{drum}}$ , calculate  $K_h$ ,  $K_b$  and  $K_p$ , and then determine  $V/F$ .

$$\text{Check: } \sum \frac{(K_i - 1)z_i}{1 + (K_i - 1)V/F} = 0 ?$$

Initial guess:  $T_{\text{drum}}$  must be less than temperature to boil pure hexane

( $K_h = 1.0$ ,  $T = 94^\circ\text{C}$ ). Try  $85^\circ\text{C}$  as first guess (this is not very critical and the calculation will tell us if there is a mistake).  $K_h = 0.8$ ,  $K_b = 4.8$ ,  $K_p = 11.7$ .

$$\frac{V}{F} = \frac{\frac{0.6}{0.85} - 1}{0.8 - 1} = 1.471. \text{ Not possible. Must have } K_h < \frac{0.6}{0.85} = 0.706$$

Try  $T = 73^\circ\text{C}$  where  $K_h = 0.6$ . Then  $K_b = 3.8$ ,  $K_p = 9.9$ .

$$\frac{V}{F} = \frac{\frac{0.6}{.85} - 1}{.6 - 1} = 0.735$$

Check:

$$\sum \frac{(K_i - 1)z_i}{1 + (K_i - 1)V/F} = \frac{(8.9)(.1)}{1 + (8.9).735} + \frac{(2.8)(.3)}{1 + (2.8).735} + \frac{(-.4)(.6)}{1 - (.4)(.735)} = 0.05276$$

Converge on  $T \sim 65.6^\circ\text{C}$  and  $V/F \sim 0.57$ .

2.D19. 90% recovery n-hexane means  $(0.9)(Fz_{C_6}) = L(x_{C_6})$

Substitute in  $L = F - V$  to obtain  $z_{C_6}(.9) = (1 - V/F)x_{C_6}$

$$C_8 \text{ balance: } z_{C_6}F = Lx_{C_6} + Vy_{C_6} = (F - V)x_{C_6} + K_{C_6}Vx_{C_6}$$

$$\text{or } z_{C_6} = (1 - V/F)x_{C_6} + x_{C_6}K_{C_6}V/F$$

Two equations and two unknowns. Remove  $x_{C_6}$  and solve

$$z_{C_6} = .93C_6 + \frac{(.9)z_{C_6}KV/F}{1 - V/F}$$

Solve for  $V/F$ .  $\frac{V}{F} = \frac{.1}{(.9K_{C_6}) + .1}$ . Trial and error scheme.

Pick  $T$ , Calc  $K_{C_6}$ , Calc  $V/F$ , and Check  $f(V/F) = 0$ ?

$$\text{If not } K_{\text{ref,new}} = \frac{K_{\text{ref}}(T_{\text{old}})}{1 + df(T)}$$

Try  $T = 70^\circ\text{C}$ .  $K_{C_4} = 3.1$ ,  $K_{C_5} = .93$ ,  $K_{C_6} = .37 = K_{\text{ref}}$

$$\frac{V}{F} = \frac{.1}{(.9)(.37) + .1} = 0.231.$$

Rachford Rice equation

$$f = \frac{(2.1).4}{1 + (2.1).231} + \frac{(-.08).25}{1 - (.08).231} - \frac{(.63).35}{1 - (.63)(.231)} = .28719$$

$$K_{\text{ref}}(T_{\text{new}}) = \frac{.37}{1 + 0.28719} = 0.28745 \text{ (use .28)}$$

Converge on  $T_{\text{New}} \sim 57^\circ\text{C}$ . Then  $K_{C_4} = 2.50$ ,  $K_{C_8} = .67$ , and  $V/F = 0.293$ .

2.D20. *New Problem 4<sup>th</sup> ed.*

2.D20 Solution:  $y_2$  &  $x_2$  in equilibrium

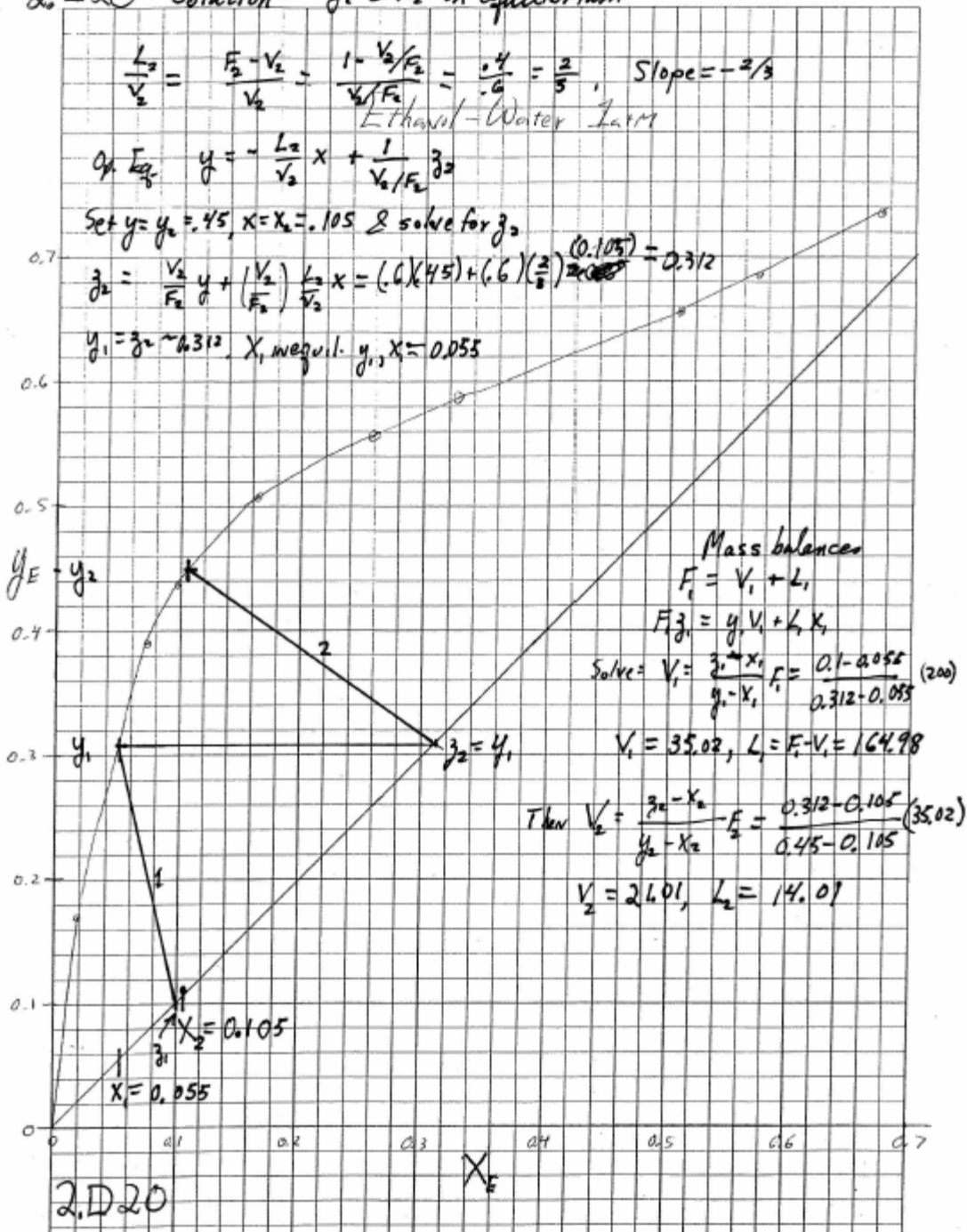

2.D21. a.)  $K_{C2} = 4.8$   $K_{C5} = 0.153$

Soln to Binary R.R. eq.  $\frac{V}{F} = \frac{-z_A}{(K_B - 1)} - \frac{z_B}{(K_A - 1)}$ ,  $\frac{V}{F} = \frac{-0.55}{(0.153 - 1)} - \frac{0.45}{(4.8 - 1)} = 0.5309$

$x_{C2} = \frac{z_{C2}}{1 + (K_{C2} - 1)\frac{V}{F}} = \frac{0.55}{1 + (3.8)(0.5309)} = 0.1823$ ,  $y_{C2} = 0.8749$ ,  $x_{C5} = 0.8177$ ,  $y_{C5} = 0.1251$

Need to convert F to kmol. Avg MW = 0.55(30.07) + 0.45(72.15) = 49.17

$$F = 100,000 \frac{\text{kg}}{\text{hr}} \left| \frac{\text{kmol}}{49.17 \text{ kg}} \right| = 2033.7 \text{ kmol/h}, \quad V = (V/F)F = 1079.7, \quad L = F - V = 954.0 \text{ kmol/h}$$

$$b.) \quad u_{\text{Perm}} = K_{\text{drum}} \sqrt{\frac{\rho_L - \rho_v}{\rho_v}}$$

$$\text{To find} \quad \overline{MW}_L = (0.1823)(30.07) + (0.8177)(72.15) = 64.48$$

$$\overline{MW}_v = (0.8749)(30.07) + (0.1251)(72.15) = 35.33$$

For liquid assume ideal mixture:

$$\overline{V}_L = x_{C2} \overline{V}_{C2,\text{liq}} + x_{C5} \overline{V}_{C5,\text{liq}} = x_{C2} \frac{\overline{MW}_{C2}}{\rho_{C2,\text{liq}}} + x_{C5} \frac{\overline{MW}_{C5}}{\rho_{C5,\text{liq}}}$$

$$\overline{V}_L = (0.1823) \frac{(30.07)}{0.54} + (0.8177) \frac{(72.15)}{(0.63)} = 103.797 \text{ ml/mol}$$

$$\rho_L = \frac{\overline{MW}_L}{\overline{V}_L} = \frac{64.48}{103.797} = 0.621 \text{ g/ml}$$

$$\text{For vapor: ideal gas: } \rho_v = \frac{\overline{MW}_v}{RT} = \frac{700 \text{ kPa} \left| \frac{\text{atm}}{101.3 \text{ kPa}} \right| \left( 35.33 \frac{\text{g}}{\text{mol}} \right)}{82.0575 \frac{\text{ml atm}}{\text{mol K}} (303.16 \text{ K})} = 0.009814 \text{ g/ml}$$

$$K_{\text{drum}}: \text{ Use Eq. (2-60) with } F_{IV} = \frac{W_L}{W_v} \sqrt{\frac{\rho_v}{\rho_L}}$$

$$W_L = 997.7 \frac{\text{kmol}}{\text{h}} \left| \frac{64.48 \text{ kg}}{\text{kmol}} \right| = 6,4331.7 \text{ kg/h}, \quad W_v = 881.5 \left| 35.33 \right| = 31,143.4 \text{ kg/h}$$

$$F_{IV} = \frac{64331.7}{31,143.3} \sqrt{\frac{0.009814}{0.621}} = 0.2597$$

$$K_{\text{drum}} = \exp \left[ -1.877478 + (-0.81458)(\ln 0.2597) + (-0.18707) [\ln 0.2597]^2 + (-0.0145229)(\ln 0.2597)^3 + (-0.0010149)(\ln 0.2597)^4 \right] = 0.3372$$

$$u_{\text{Perm}} = (0.3372) \sqrt{\frac{0.621 - 0.009814 \text{ ft}}{0.009814} \left| \frac{1.0 \text{ m}}{3.2808 \text{ ft}} \right|} = 0.8111 \text{ m/s}$$

$$A_c = \frac{V \overline{MW}_v}{u_{\text{Perm}} 3600 \rho_v} = \frac{\left( 1079.7 \frac{\text{kmol}}{\text{h}} \right) \left( 35.33 \frac{\text{kg}}{\text{kmol}} \right)}{0.8111 \frac{\text{m}}{\text{s}} \left( 3600 \frac{\text{s}}{\text{h}} \right) \left( 0.009814 \frac{\text{g}}{\text{cm}^3} \right) \left( \frac{\text{kg}}{1000 \text{g}} \right) \left( \frac{10^6 \text{ cm}^3}{\text{m}^3} \right)} = 1.392 \text{ m}^2$$

$$D = \sqrt{4A_c/\pi} = 1.33 \text{ m. Arbitrarily } L/D = 4, \quad L = 5.32 \text{ m}$$

2.D22. *New problem in 4<sup>th</sup> edition.*

a.  $V = F - L = 50 - 20 = 20 \text{ kmol/h}$ .  $V/F = 3/5$ , Slope operating line =  $-L/V = -20/30 = -2/3$ ,  $z_M = 0.7$

From graph,  $y = 0.8$ ,  $x = 0.54$ .

b. From graph of  $T$  vs.  $x_M$ ,  $T_{\text{drum}} = 72.3^\circ\text{C}$ . (see graph).

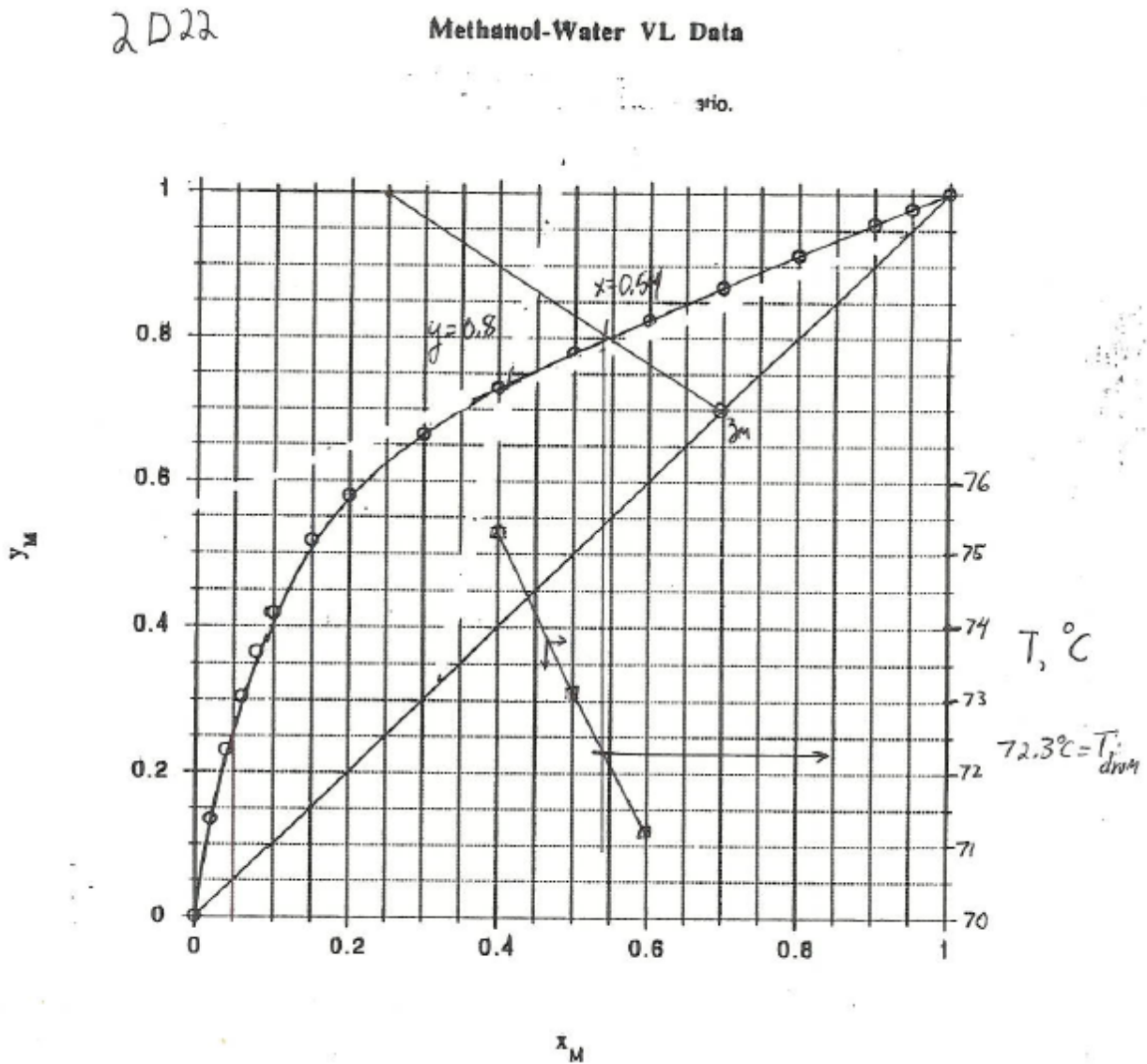

2.D23. New Problem 4<sup>th</sup> ed.

Part a.  $F_{\text{new}} = (1500 \text{ kmol/h})(1.0 \text{ lbmol}/(0.45359 \text{ kmol})) = 3307 \text{ lb mol/h}$ .

$V$ ,  $W_V$ ,  $L$ , and  $W_L$  are the values in Example 2-4 divided by 0.45359. The conversion factor divides out in

$F_{\text{IV}}$  term. Thus,  $F_{\text{IV}}$ ,  $K_{\text{drum}}$ , and  $u_{\text{perm}}$  are the same as in Example 2-4. The Area increases because  $V$  increases:  $\text{Area} = \text{Area}_{\text{Example 2-4}}/0.45359 = 16.047/0.45359 = 35.38 \text{ ft}^2$ .

$$\text{Diameter} = \sqrt{4\text{Area} / \pi} = 6.71 \text{ feet}$$

Probably round this off to 7.0 feet and use a drum height of 28 feet.

b.  $F_{\text{parallel}} = 3307 - 1500 = 1807 \text{ lbmol/h}$ .

$F_{\text{IV}}$ ,  $K_{\text{drum}}$ , and  $u_{\text{perm}}$  are the same as in Example 2-4.  $V_{\text{parallel}} = (V/F) F_{\text{parallel}} = 0.51 (1807) = 921.6 \text{ kmol/h}$ .

$$A_c = 16.047 \times \frac{V_{parallel}}{V_{Example\_2-4}} = 16.047 \times (921.6 / 765) = 19.33 \text{ ft}^2$$

Then,  $Diameter = \sqrt{4Area / \pi} = 4.96 \text{ feet}$ , Use a 5.0 feet diameter and a length of 20 feet.

2.D24.  $p = 300 \text{ kPa}$  At any  $T$ .  $K_{C3} = y_{C3}/x_{C3}$ ,  $K$ 's are known.  $K_{C6} = y_{C6}/x_{C6} = (1 - y_{C3})/(1 - x_{C3})$

Substitute 1<sup>st</sup> equation into 2<sup>nd</sup>  $K_{C6} = (1 - K_{C3}x_{C3})/(1 - x_{C3})$

Solve for  $x_{C3}$ ,  $(1 - x_{C3})K_{C6} = 1 - K_{C3}x_{C3}$ ,  $x_{C3}(K_{C3} - K_{C6}) = 1 - K_{C6}$

$$x_{C3} = \frac{1 - K_{C6}}{K_{C3} - K_{C6}} \quad \& \quad y_{C3} = \frac{K_{C3}(1 - K_{C6})}{K_{C3} - K_{C6}}$$

At 300 kPa pure propane ( $K_{C3} = 1.0$ ) boils at  $-14^\circ\text{C}$  (Fig. 2-10)

At 300 kPa pure n-hexane ( $K_{C6} = 1.0$ ) boils at  $110^\circ\text{C}$

Check: at  $-14^\circ\text{C}$   $x_{C3} = \frac{1 - K_{C6}}{1 - K_{C6}} = 1$ ,  $y_{C3} = \frac{1(1 - K_{C6})}{1 - K_{C6}} = 1.0$

at  $110^\circ\text{C}$   $x_{C3} = \frac{0}{K_{C3}} = 0$ ,  $y_{C3} = \frac{K_{C3}(0)}{K_{C3}} = 0$

Pick intermediate temperatures, find  $K_{C3}$  &  $K_{C6}$ , calculate  $x_{C3}$  &  $y_{C3}$ .

T	$K_{C3}$	$K_{C6}$	$x_{C3}$	$y_{C3} = K_{C3}x_{C3}$	
$0^\circ\text{C}$	1.45	0.027	$\frac{1 - 0.027}{1.45 - 0.027} = 0.684$	0.9915	
$10^\circ\text{C}$	2.1	0.044	0.465	0.976	See
$20^\circ\text{C}$	2.6	0.069	0.368	0.956	Graph
$30^\circ\text{C}$	3.3	0.105	0.280	0.924	
$40^\circ\text{C}$	3.9	0.15	0.227	0.884	
$50^\circ\text{C}$	4.7	0.21	0.176	0.827	
$60^\circ\text{C}$	5.5	0.29	0.136	0.75	
$70^\circ\text{C}$	6.4	0.38	0.103	0.659	

b.  $x_{C3} = 0.3$ ,  $V/F = 0.4$ ,  $L/V = 0.6/0.4 = 1.5$

Operating line intersects  $y = x = 0.3$ , Slope  $-1.5$

$$y = -\frac{L}{V}x + \frac{F}{V}z \quad \text{at} \quad x = 0, \quad y = \frac{F}{V}z = \frac{0.3}{0.4} = 0.75$$

Find  $y_{C3} = 0.63$  and  $x_{C3} = 0.062$

Check with operating line:  $0.63 = -1.5(.062) + 0.75 = 0.657$  OK within accuracy of the graph.

c. Drum T:  $K_{C3} = y_{C3}/x_{C3} = 0.63/0.062 \approx 10.2$ , DePriester Chart  $T = 109^\circ\text{C}$

d.  $y = .8$ ,  $x \sim .16$  Slope  $= -\frac{L}{V} = \frac{\Delta y}{\Delta x} = \frac{.8 - .6}{.16 - .6} = -0.45 = -\frac{1-f}{f} = -.45$

$V/F = f = 1/1.45 = 0.69$

306 HW1, 2008  
 Prob 1

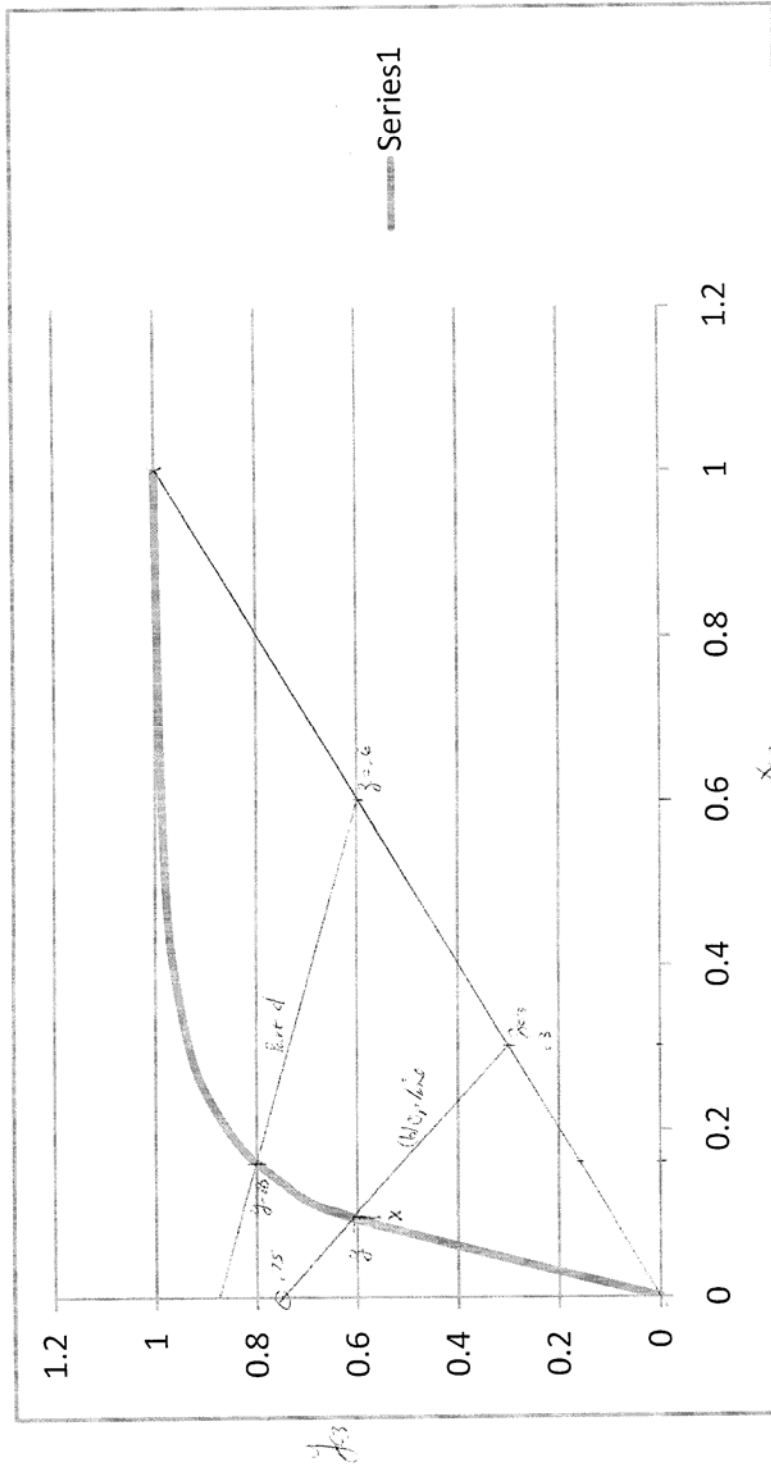

2.D25. 20% Methane and 80% n-butane.  $T_{\text{drum}} = .50^\circ\text{C}$ ,  $\frac{V}{F} = 0.40$ , Find  $p_{\text{drum}}$

$$0 = f\left(\frac{V}{F}\right) = \frac{(K_A - 1)z_A}{1 + (K_A - 1)\left(\frac{V}{F}\right)} + \frac{(K_B - 1)z_B}{1 + (K_B - 1)\frac{V}{F}}$$

Pick  $p_{\text{drum}} = 1500 \text{ kPa}$ :  $K_{C4} = 13$        $K_{nC4} = 0.4$   
 (Any pressure with  $K_{C1} > 1$  and  $K_{C4} < 1.0$  is OK)

Trial 1       $f_1 = \frac{12(.2)}{1 + 12(.4)} + \frac{(-.6)(.8)}{1 - .6(.4)} = -0.2178$       Need lower  $p_{\text{drum}}$

$$K_{C4}(P_{\text{new}}) = \frac{K_{C4}(P_{\text{old}})}{1 + (d)f(P_{\text{old}})} = \frac{(0.4)}{1 + (-.2138)} = 0.511 \text{ with } d = 1.0$$

$P_{\text{new}} = 1160$        $K_{C1} = 16.5$ ,  $f_2 = \frac{(15.5)(.2)}{1 + 15.5(.4)} + \frac{-.489(.8)}{1 - (.489)(.4)} = 0.4305 + -.4863 = -0.055769$

$$K_{C4}(P_{\text{new}}) = \frac{0.511}{1 + -0.055769} = 0.541, \quad P_{\text{new}} = 1100, \quad K_{C1} = 17.4$$

$$f_3 = \frac{16.4(.2)}{1 + (16.4)(.4)} + \frac{(-.459)(.8)}{1 - (.459)(.4)} = -0.0159, \text{ OK. Drum pressure} = 1100 \text{ kPa}$$

b.)       $x_i = \frac{z_i}{1 + (K_i - 1)\frac{V}{F}}, \quad x_{C1} = \frac{0.2}{1 + (16.4)(.4)} = 0.02645$

$$y_{C1} = K_{C1}x_{C1} = (17.4)(0.02645) = 0.4603$$

2.D26. a) Can solve for L and V from M.B.

$$100 = F = V + L$$

$$45 = Fz = 0.8V + 0.2162L$$

Find:

$$L = 59.95 \text{ and } V = 40.05$$

b) Stage is equil.       $K_{C3} = \frac{y_{C3}}{x_{C3}} = \frac{0.8}{0.2162} = 3.700, \quad K_{C5} = \frac{0.2}{0.7838} = .2552$

These K values are at same T, P. Find these 2 K values on DePriester chart.

Draw straight line between them. Extend to  $T_{\text{drum}}, p_{\text{drum}}$ . Find  $10^\circ\text{C}, 160 \text{ kPa}$ .

2.D27. a.)  $VP_{C5} : \log_{10} VP = 6.853 - \frac{1064.8}{0 + 233.01} = 2.2832, \quad VP = 191.97 \text{ mmHg}$

b.)  $VP = 3 \times 760 = 2280 \text{ mmHg}, \quad \log_{10} VP = (6.853) - 1064.8 / (T + 233.01)$

Solve for  $T = 71.65^\circ\text{C}$

c.)       $P_{\text{tot}} = 191.97 \text{ mm Hg}$  [at boiling for pure component  $P_{\text{tot}} = VP$ ]

d.) C5:  $\log_{10} VP = 6.853 - \frac{1064.8}{30 + 233.01} = 2.8045, \quad VP = 637.51 \text{ mm Hg}$

$$K_{C5} = VP_{C5} / P_{\text{tot}} = 637.51 / 500 = 1.2750$$

$$C6: \log_{10} VP_{C6} = 6.876 - \frac{1171.17}{30 + 224.41} = 2.2725, \quad VP_{C6} = 187.29 \text{ mm Hg}$$

$$K_{C6} = 187.29/500 = 0.3746$$

e.)  $K_A = y_A/x_A$                        $K_B = y_B/x_B = (1-y_A)/(1-x_A)$   
 If  $K_A$  &  $K_B$  are known, two eqns. with 2 unknowns ( $K_A$  &  $y_A$ )    Solve.

$$x_{C5} = \frac{1 - K_{C6}}{K_{C5} - K_{C6}} = \frac{1 - 0.3746}{1.2750 - 0.3746} = 0.6946$$

$$y_{C5} = K_{C5}x_{C5} = (1.2750)(0.6946) = 0.8856$$

f.) Overall, M.B.,  $F = L + V$     or  $1 = L + V$

$$C5: Fx_F = Lx + Vy \quad .75 = 0.6946 L + 0.8856 V$$

Solve for L & V:  $L = 0.7099$  &  $V = 0.2901$  mol

g.) Same as part f, except units are mol/min.

2.D28.

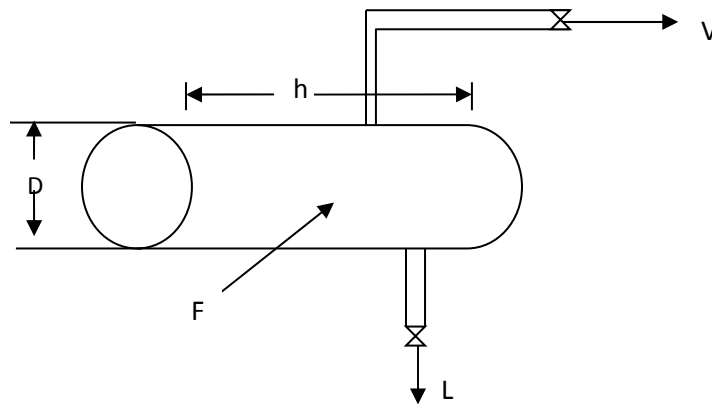

From example 2-4,  $x_H = 0.19$ ,  $T_{\text{drum}} = 378\text{K}$ ,  $V/F = 0.51$ ,  $y_H = 0.6$ ,  $z_H = 0.40$

$MW_v = 97.39$  lbm/lbmole (Example 2-4)

$$\rho_v = 3.14 \times 10^{-3} \text{ g/mol} \left| \frac{1}{454 \text{ g/lbm}} \right| \frac{28316.85 \text{ cm}^3}{\text{ft}^3} = 0.198 \frac{\text{lbm}}{\text{ft}^3}$$

Example 2.4

$$u_{\text{perm}} = K_{\text{drum}} \sqrt{\frac{\rho_L - \rho_v}{\rho_v}}, \quad K_{\text{horiz}} = 1.25 K_{\text{vertical}}$$

From Example 2-4,  $K_{\text{vertical}} = 0.4433$ ,  $K_{\text{horiz}} = 1.25(0.4433) = 0.5541$

$$u_{\text{perm}} = 0.5541 \left( \frac{0.6960 - 0.00314}{0.00314} \right)^{1/2} = 8.231 \text{ ft/s [densities from Example 2-4]}$$

$$V = \left(\frac{V}{F}\right)F = (0.51)\left(3000\frac{\text{lbmol}}{\text{h}}\right) = 1530 \text{ lbmol/h}$$

$$A_{\text{vap}} = \frac{1530\frac{\text{lbmol}}{\text{h}}\left(97.39\frac{\text{lbm}}{\text{lbmole}}\right)}{\left(8.231\frac{\text{ft}}{\text{s}}\right)\left(3600\frac{\text{s}}{\text{h}}\right)\left(0.1958\frac{\text{lbm}}{\text{ft}^3}\right)} = 25.68 \text{ ft}^2$$

$$A_{\text{total}} = A_{\text{vap}} / 0.2 = 128.4\text{ft}^2, D_{\text{min}} = \sqrt{4A_{\text{total}} / \pi} = 12.8\text{ft}$$

$$V_{\text{liq}} = \frac{160,068}{43.41} \frac{55+85}{60 \text{ min/h}} = 8603.8\text{ft}^3, h = \frac{5V_{\text{liq}}}{\pi D^2} = 83.51\text{ft and } h/D = 6.5.$$

2.D29. The stream tables in Aspen Plus include a line stating the fraction vapor in a given stream. Change the feed pressure until the feed stream is all liquid (fraction vapor = 0). For the Peng-Robinson correlation the appropriate pressure is 74 atm.

The feed *mole* fractions are: methane = 0.4569, propane = 0.3087, n-butane = 0.1441, i-butane = 0.0661, and n-pentane = 0.0242.

b. At 74 atm, the Aspen Plus results are; L = 10169.84 kg/h = 201.636 kmol/h, V = 4830.16 kg/h = 228.098 kmol/h, and T<sub>drum</sub> = -40.22 °C.

The vapor mole fractions are: methane = 0.8296, propane = 0.1458, n-butane = 0.0143, i-butane = 0.0097, and n-pentane = 0.0006.

The liquid mole fractions are: methane = 0.0353, propane = 0.4930, n-butane = 0.2910, i-butane = 0.1298, and n-pentane = 0.0509.

c. Aspen Plus gives the liquid density = 0.60786 g/cc, liquid avg MW = 50.4367, vapor density = 0.004578 g/cc = 4.578 kg/m<sup>3</sup>, and vapor avg MW = 21.17579 g/mol = kg/kmol.

The value of u<sub>perm</sub> (in ft/s) can be determined by combining Eqs. (2-64), (2-65) and (2-69)

$$F_{\text{lv}} = (W_L/W_V)[\rho_V/\rho_L]^{0.5} = (10169.84/4830.16)[0.004578/0.60786]^{0.5} = 0.18272$$

Resulting K<sub>vertical</sub> = 0.378887, K<sub>horizontal</sub> = 0.473608, and u<sub>perm</sub> = 5.436779 ft/s = 1.657m/s

$$A_{\text{vap}} = \frac{4830.16\frac{\text{kg}}{\text{h}}}{\left(1.657\frac{\text{m}}{\text{s}}\right)\left(3600\frac{\text{s}}{\text{h}}\right)\left(4.578\frac{\text{kg}}{\text{m}^3}\right)} = 0.177 \text{ m}^2$$

$$A_{\text{total}} = A_{\text{vap}} / 0.2 = 0.884 \text{ m}^2, D_{\text{min}} = \sqrt{4A_{\text{total}} / \pi} = 1.06 \text{ m}$$

$$h / D = 6 = \frac{5V_{\text{liq}}}{\pi D^2}, \text{ thus } V_{\text{liq}} = 6\pi D^2 / 5 = 4.23 \text{ m}^3$$

$$V_{\text{liq}} = (V \text{ ol rate})(\text{hold time} + \text{surge time}) = \left(\frac{10169.84 \text{ kg/h}}{607.86 \text{ kg/m}^3}\right)(9/60 + \text{st})$$

$$\text{st} = 607.86 V_{\text{liq}} / 10169.84 - 9/60 = 0.103 \text{ hours} = 6.18 \text{ min}$$

2.D30.. a. From the equilibrium data if y<sub>A</sub> = .40 mole fraction water, then x<sub>A</sub> = 0.09 mole fraction water. Can find L<sub>A</sub> and V<sub>A</sub> by solving the two mass balances for stage A simultaneously.

L<sub>A</sub> + V<sub>A</sub> = F<sub>A</sub> = 100 and L<sub>A</sub> (.09) + V<sub>A</sub> (.40) = (100) (.20). The results are V<sub>A</sub> = 35.48 and L<sub>A</sub> = 64.52.

b. In chamber B, since 40 % of the vapor is condensed,  $(V/F)_B = 0.6$ . The operating line for this flash chamber is,

$y = -(L/V)x + F_B/V z_B$  where  $z_B = y_A = 0.4$  and  $L/V + .4F_B/.6F_B = 2/3$ . This operating line goes through the point  $y = x = z_B = 0.4$  with a slope of  $-2/3$ . This is shown on the graph. Obtain  $x_B = 0.18$  &  $y_B = 0.54$ .  $L_B = (\text{fraction condensed})(\text{feed to B}) = 0.4(35.48) = 14.19 \text{ kmol/h}$  and  $V_B = F_B - L_B = 21.29$ .

c. From the equilibrium if  $x_B = 0.20$ ,  $y_B = 0.57$ . Then solving the mass balances in the same way as for part a with  $F_B = 35.48$  and  $z_B = 0.4$ ,  $L_B = 16.30$  and  $V_B = 19.18$ . Because  $x_B = z_A$ , recycling  $L_B$  does not change  $y_B = 0.57$  or  $x_A = 0.09$ , but it changes the flow rates  $V_{B,\text{new}}$  and  $L_{A,\text{new}}$ . With recycle these can be found from the overall mass balances:  $F = V_{B,\text{new}} + L_{A,\text{new}}$  and  $Fz_A = V_{B,\text{new}}y_B + L_{A,\text{new}}x_A$ . Then  $V_{B,\text{new}} = 22.92$  and  $L_{A,\text{new}} = 77.08$ .

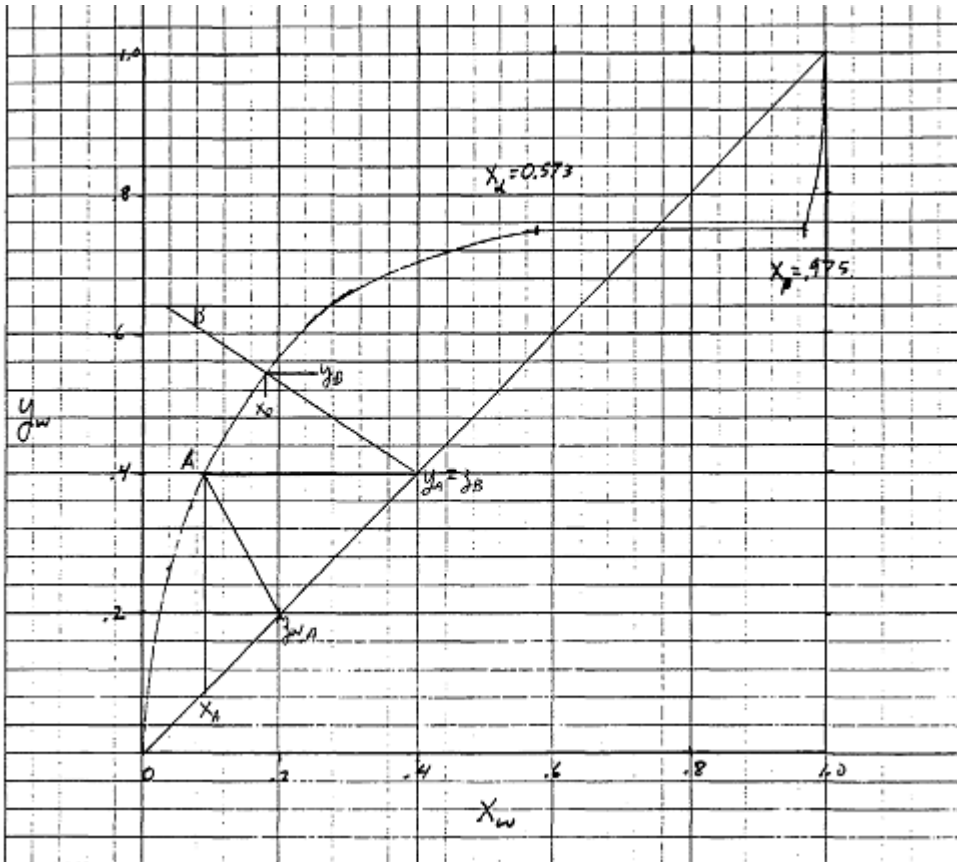

Graph for problem 2.D30.

2.D31. *New problem in 4<sup>th</sup> US edition. Was 2.D13 in 3<sup>rd</sup> International Edition.*

a) Since  $K$ 's are for mole fractions, need to convert feed to mole fractions.

Basis: 100 kg feed

$50 \text{ kg } n_{C_4}$	$\frac{1 \text{ kmol}}{58.12 \text{ kg}}$	$= 0.8603 \text{ kmol}$	$z_4 = 0.555$
$50 \text{ kg } n_{C_5}$	$\frac{1 \text{ kmol}}{72.5 \text{ kg}}$	$= 0.6897 \text{ kmol } n_{C_5}$	$z_5 = 0.445$
Total	$1.5499 \text{ kmol}$		

DePriester Chart  $K_{C4} = 2.05$ ,  $K_{C5} = 0.58$ , (Result similar if use Raoult's law).

$$\frac{V}{F} = \frac{-0.555}{0.58-1} - \frac{0.445}{1.05} = 1.3214 - 0.424 = 0.8976$$

Check  $f\left(\frac{V}{F}\right) = \frac{(1.05)(.555)}{1+(.05)(.8976)} + \frac{(-.42).445}{1-.42(.8976)} = 0.3000 - .29999 = 0$  OK

Eq. 3.23  $x_{C4} = \frac{z_{C4}}{1+(K_{C4}-1)V/F} = \frac{.555}{1+1.056(.8976)} = 0.2857$  ,

$$x_{C5} = .7143 \quad y_{C4} = K_{C4}x_{C4} = 0.5857 \quad , \quad y_{C5} = 0.4143$$

b) From problem 2.D.g.,  $K_{C4} = 1.019$  and  $K_{C5} = 0.253$  .

Solving RR equation,

$$\frac{V}{F} = \left[ -\frac{z_A}{(K_B-1)} - \frac{z_B}{(K_A-1)} \right] = \frac{-.555}{(0.253-1)} - \frac{0.445}{0.019} = -23.28$$

NOT possible. Won't flash at 0°C.

2.D32. New problem in 4<sup>th</sup> US edition. Was 2.D28 in 3<sup>rd</sup> International Edition.

$$\left(\frac{V}{F}\right)_A = 2/3, \quad L/V = \frac{1/3}{2/3} = 1/2 \quad \text{Slope} = -1/2 \quad \text{Through } y = x = z_A = 0.6 \quad \text{See figure}$$

a.  $L_A = \frac{1}{3}F = 33.33$ ,  $x_{M,A} = 0.375$  (from Figure)  $V_A = \frac{2}{3}F = 66.67$ ,  $y_{M,A} = 0.72$  (from Figure)

$$\left.\frac{V}{F}\right|_B = 0.4 \quad -\left(\frac{L}{V}\right)_B = -\frac{1-f}{f} = -\frac{0.6}{0.4} = -1.5$$

Through  $y = x = z_B = y_A = 0.72$

$$V_B = 0.4F_B = 0.4V_A = 0.4(66.67) = 26.67, \quad L_B = 0.6F_B = 0.6(66.67) = 40.00$$

b.  $z_C = x_A = 0.375$ ,  $x_C = 0.15$ ,  $F_C = L_A = 33.33$ , From equilibrium  $y_C = 0.51$

$$\text{At } x = 0, \quad y_C = 0.60 = \left(\frac{F}{V}\right)_C z_C \Rightarrow \left(\frac{V}{F}\right)_C = \frac{z_C}{y_C} = \frac{0.375}{0.6} = 0.625$$

$$V_C = \left(\frac{V}{F}\right)_C F_C = 0.625(33.33) = 20.83, \quad L_C = F_C - V_C = 33.33 - 20.83 = 12.5$$

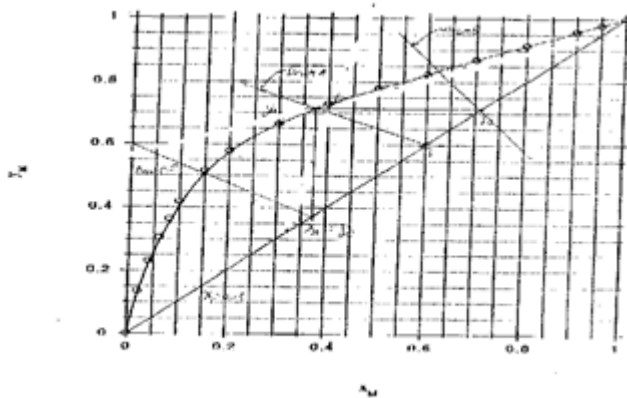

2.E1. From Aspen Plus run with 1000 kmol/h at 1 bar,  $L = V = 500$  kmol/h,  $W_L = 9212.78$  kg/h,  $W_V = 13010.57$  kg/h, liquid density =  $916.14$  kg/m<sup>3</sup>, liquid avg MW = 18.43, vapor density =  $0.85$  kg/m<sup>3</sup>, and vapor avg MW = 26.02,  $T_{\text{drum}} = 94.1$  °C, and  $Q = 6240.85$  kW.

The diameter of the vertical drum in meters (with  $u_{\text{perm}}$  in ft/s) is

$$D = \left\{ \frac{[4(MW_V) V]}{[3600 \pi \rho_V u_{\text{perm}} (1 \text{ m}/3.281 \text{ ft})]} \right\}^{0.5} = \left\{ \frac{[4(26.02)(500)]}{[3600(3.14159)(0.85)(1/3.281)u_{\text{perm}}]} \right\}^{0.5}$$

$$F_{lv} = (W_L/W_V)[\rho_V/\rho_L]^{0.5} = (9212.78/13010.57)[0.85/916.14]^{0.5} = 0.02157$$

Resulting  $K_{\text{vertical}} = 0.404299$ , and  $u_{\text{perm}} = 13.2699$  ft/s, and  $D = 1.16$  m. Appropriate standard size would be used. Mole fractions isopropanol: liquid = 0.00975, vapor = 0.1903

b. Ran with feed at 9 bar and  $p_{\text{drum}}$  at 8.9 bar with  $V/F = 0.5$ . Obtain  $W_L = 9155.07$  kg/h,  $W_V = 13068.27$ , density liquid = 836.89, density vapor = 6.37 kg/m<sup>3</sup>

$$D = \left\{ \frac{[4(MW_V) V]}{[3600 \pi \rho_V u_{\text{perm}} (1 \text{ m}/3.281 \text{ ft})]} \right\}^{0.5} = \left\{ \frac{[4(26.14)(500)]}{[3600(3.14159)(6.37)(1/3.281)u_{\text{perm}}]} \right\}^{0.5}$$

$$F_{lv} = (W_L/W_V)[\rho_V/\rho_L]^{0.5} = (9155.07/13068.27)[6.37/836.89]^{0.5} = 0.06112$$

Resulting  $K_{\text{vertical}} = .446199$ ,  $u_{\text{perm}} = 5.094885$  ft/s, and  $D = 0.684$  m. Thus, the method is feasible.

c. Finding a pressure to match the diameter of the existing drum is trial and error. If we do a linear interpolation between the two simulations to find a pressure that will give us  $D = 1.0$  m (if linear), we find  $p = 3.66$ . Running this simulation we obtain,  $W_L = 9173.91$  kg/h,  $W_V = 13049.43$ , density liquid = 874.58, density vapor = 2.83 kg/m<sup>3</sup>,  $MW_V = 26.10$

$$D = \left\{ \frac{[4(MW_V) V]}{[3600 \pi \rho_V u_{\text{perm}} (1 \text{ m}/3.281 \text{ ft})]} \right\}^{0.5} = \left\{ \frac{[4(26.10)(500)]}{[3600(3.14159)(2.83)(1/3.281)u_{\text{perm}}]} \right\}^{0.5}$$

$$F_{lv} = (W_L/W_V)[\rho_V/\rho_L]^{0.5} = (9173.91/13049.43)[2.83/874.58]^{0.5} = 0.0400$$

Resulting  $K_{\text{vertical}} = .441162$ ,  $u_{\text{perm}} = 7.742851$  ft/s, and  $D = 0.831$  m.

Plotting the curve of  $D$  versus  $p_{\text{drum}}$  and setting  $D = 1.0$ , we interpolate  $p_{\text{drum}} = 2.1$  bar. At  $p_{\text{drum}} = 2.1$  bar simulation gives,  $W_L = 9188.82$  kg/h,  $W_V = 13034.53$ , density liquid = 893.99, density vapor = 1.69 kg/m<sup>3</sup>,  $MW_V = 26.07$ .

$$D = \left\{ \frac{[4(MW_V) V]}{[3600 \pi \rho_V u_{\text{perm}} (1 \text{ m}/3.281 \text{ ft})]} \right\}^{0.5} = \left\{ \frac{[4(26.07)(500)]}{[3600(3.14159)(1.69)(1/3.281)u_{\text{perm}}]} \right\}^{0.5}$$

$$F_{lv} = (W_L/W_V)[\rho_V/\rho_L]^{0.5} = (9188.82/13034.53)[1.69/893.99]^{0.5} = 0.0307$$

Resulting  $K_{\text{vertical}} = .42933$ ,  $u_{\text{perm}} = 9.865175$  ft/s, and  $D = 0.953$  m.

This is reasonably close and will work OK.  $T_{\text{drum}} = 115.42$  °C,  $Q = 6630.39$  kW, Mole fractions isopropanol: liquid = 0.00861, vapor = 0.1914

In this case there is an advantage operating at a somewhat elevated pressure.

2.E2. This problem was 2.D13 in the 2<sup>nd</sup> edition of *SPE*.

a. Will show graphical solution as a binary flash distillation. Can also use R-R equation. To generate equil. data can use

$$x_{C6} + x_{C8} = 1.0, \text{ and } y_{C6} + y_{C8} = K_{C6}x_{C6} + K_{C8}x_{C8} = 1.0$$

Substitute for  $x_{C6}$  
$$x_{C6} = \frac{1 - K_{C8}}{K_{C6} - K_{C8}}$$

Pick T, find  $K_{C6}$  and  $K_{C8}$  (e.g. from DePriester charts), solve for  $x_{C6}$ . Then  $y_{C6} = K_{C6}x_{C6}$

T°C	$K_{C6}$	$K_{C8}$	$x_{C6}$	$y_{C6} = K_{C6}x_{C6}$
125	4	1.0	0	0
120	3.7	.90	.0357	.321
110	3.0	.68	.1379	.141
100	2.37	.52	.2595	.615
90	1.8	.37	.4406	.793
80	1.4	.26	.650	.909
66.5	1.0	.17	1.0	1.0

Op Line Slope =  $-\frac{L}{V} = -\frac{1 - V/F}{V/F} = -\frac{.6}{.4} = -1.5$ , Intersection  $y = x = z = 0.65$ .

See Figure.  $y_{C6} = 0.85$  and  $x_{C6} = 0.52$ . Thus  $K_{C6} = .85/.52 = 1.63$ .  
This corresponds to  $T = 86^\circ\text{C} = 359\text{K}$

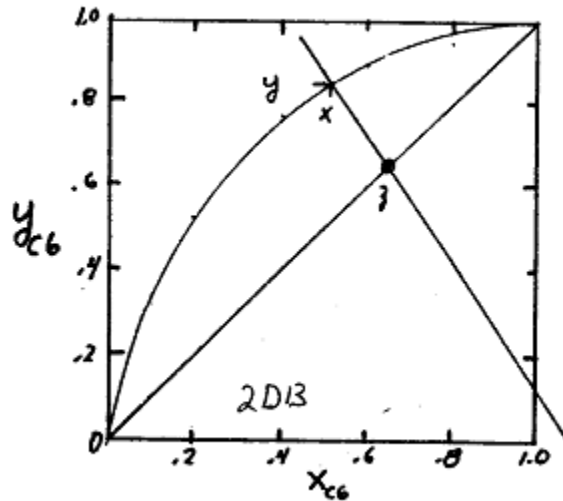

b. Follows Example 2-4.

$$\overline{MW}_L = x_{C6}(\text{MW})_{C6} + x_{C8}(\text{MW})_{C8} = (.52)(86.17) + (.48)(114.22) = 99.63$$

$$\bar{V}_L = x_{C6} \frac{(\text{MW})_{C6}}{\rho_{C6}} + x_{C8} \frac{(\text{MW})_{C8}}{\rho_{C8}} = (.52) \frac{86.17}{.659} + (.48) \frac{114.22}{.703} = 145.98 \text{ ml/mol}$$

$$\rho_L = \frac{\overline{MW}_L}{\bar{V}_L} = \frac{99.63}{145.98} = .682 \text{ g/ml} \left[ \frac{28316 \text{ ml/ft}^3}{454 \text{ g/lbm}} \right] = 42.57 \frac{\text{lbm}}{\text{ft}^3}$$

$$\overline{MW}_v = y_{C_6} (MW_{C_6}) + y_{C_8} (MW_{C_8}) = .85(86.17) + .15(114.22) = 90.38$$

$$\rho_v = \frac{p \overline{MW}_v}{RT} = \frac{(1.0)90.38 \text{ g/mol}}{82.0575 \frac{\text{ml atm}}{\text{mol} \cdot \text{K}} (359\text{K})} = 0.00307 \text{ g/ml} = 0.19135 \text{ lbm/ft}^3$$

Now we can determine flow rates

$$V = \left( \frac{V}{F} \right) F = (.4)(10,000) = 4000 \text{ lbmol/h}$$

$$W_v = V(\overline{MW}_v) = 4000(90.38) = 361,520 \text{ lb/h}$$

$$L = F - V = 6000 \text{ lbmol/h}, W_L = L(\overline{MW}_L) = (6000)(99.63) = 597,780 \text{ lb/h}$$

$$F_{lv} = \frac{W_L}{W_v} \sqrt{\frac{\rho_v}{\rho_L}} = \frac{597,780}{361,520} \sqrt{\frac{0.19135}{42.57}} = 0.1111, \ln F_{lv} = -2.1995$$

$$K_{\text{drum}} = \exp \left[ (-1.87748) + (-.81458)(-2.1995) + (-.18707)(-2.1995)^2 + (-0.01452)(-2.1995)^3 + (-0.00101)(-2.1995)^4 \right] = 0.423$$

$$u_{\text{Perm}} = K_{\text{drum}} \sqrt{\rho_L - \rho_v / \rho_v} = (0.423) \sqrt{(42.57 - 19135) / .19135} = 6.30 \text{ ft/s}$$

$$A_{Cs} = \frac{V(\overline{MW}_v)}{u_{\text{Perm}}(3600)\rho_v} = \frac{(4000)(90.38)}{(6.3)(3600)(0.19135)} = 83.33 \text{ ft}^2$$

$$D = \sqrt{4A_{Cs} / \pi} = \sqrt{4(83.33) / \pi} = 10.3 \text{ ft. Use } 10.5 \text{ ft.}$$

L ranges from  $3 \times 10.5 = 31.5 \text{ ft}$  to  $5 \times 10.5 = 52.5 \text{ ft}$ .

Note: This  $u_{\text{Perm}}$  is at 85% of flood. If we want to operate at lower % flood (say 75%)

$$u_{\text{Perm}75\%} = (0.75/0.85) u_{\text{Perm}85\%} = (0.75/0.85)(.63) = 5.56$$

Then at 75% of flood,  $A_{Cs} = 94.44$  which is  $D = 10.96$  or  $11.0 \text{ ft}$ .

- 2.E3. *New problem 4<sup>th</sup> edition.* The difficulty of this problem is it is stated in weight units, but the VLE data is in molar units. The easiest solution path is to work in weight units, which requires converting some of the equilibrium data to weight units and replotting – good practice. The difficulty with trying to work in molar units is the ratio  $L/V = 0.35/0.65 = 0.5385$  in weight units becomes in molar units,

$$\frac{L_{\text{molar}}}{V_{\text{molar}}} = \frac{L_{\text{wt}} (MW)_{\text{vapor}}}{V_{\text{wt}} (MW)_{\text{liquid}}}, \text{ but } x \text{ and } y \text{ are not known the molecular weights are unknown.}$$

In weight units,  $V = F(V/F) = 2000 \text{ kg/h} (0.35) = 700 \text{ kg/h}$ .  $L = F - V = 1300 \text{ kg/h}$ .

In weight units the equilibrium data (Table 2-7) can be converted as follows:

Basis: 1 mol,  $x = 0.4$  and  $y = 0.729$ ,  $T = 75.3 \text{ C}$

Liquid:  $0.4 \text{ mol methanol} \times 32.04 \text{ g/mol} = 12.816 \text{ g}$

$0.6 \text{ mol water} \times 18.016 \text{ g/mol} = 10.8096 \text{ g}$

Total =  $23.6256 \text{ g} \rightarrow x = 0.5425 \text{ wt frac methanol}$

Vapor:  $0.729 \text{ mol methanol} = 23.357 \text{ g}$

$0.271 \text{ mol water} = 4.881 \text{ g}$

$28.238 \text{ g} \rightarrow y = 0.8271 \text{ wt frac methanol}$ .

Similar calculations for: 0.3 mole frac liquid give  $x_{wt} = 0.433$  and  $y_{wt} = 0.7793$ ,  $T = 78.0$  C  
 0.2 mole frac liquid give  $x_{wt} = 0.3078$  and  $y_{wt} = 0.7099$ ,  $T = 81.7$  C  
 0.15 mole frac liquid give  $x_{wt} = 0.2389$  and  $y_{wt} = 0.6557$ ,  $T = 84.4$  C.

Plot this data on  $y_{wt}$  vs  $x_{wt}$  diagram. Operating line is  $y = - (L/V)x + (F/V)z$  in weight units.

Slope = - 1.857,  $y = x = z = 0.45$ , and y intercept =  $z/(V/F) = 1.286$  all in weight units.

Result is  $x_{M,wt} = 0.309$ ,  $y_{M,wt} = 0.709$  (see graph). Note that plotting only the part of the graph needed to solve the problem, the scale could be increased resulting in better accuracy. By linear interpolation  $T_{drum} = 81.66$  C.

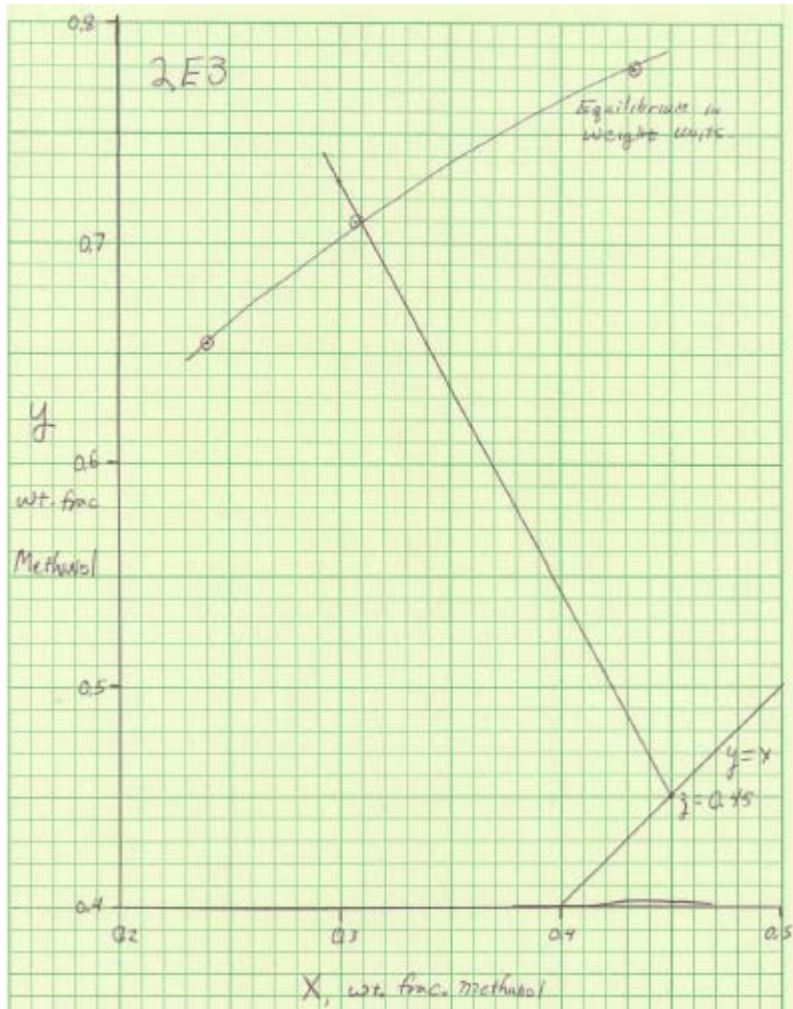

2.F1

$x_B$	0	.1	.2	.3	.4	.5	.6	.7	.8	.9	1
$y_B$	0	.22	.38	.52	.62	.71	.79	.85	.91	.96	1

Benzene-toluene equilibrium is plotted in Figure 13-8 of *Perry's Chemical Engineers Handbook*, 6<sup>th</sup> ed.

2.F2.

See Graph. Data is from *Perry's Chemical Engineers Handbook*, 6<sup>th</sup> ed., p. 13-12.

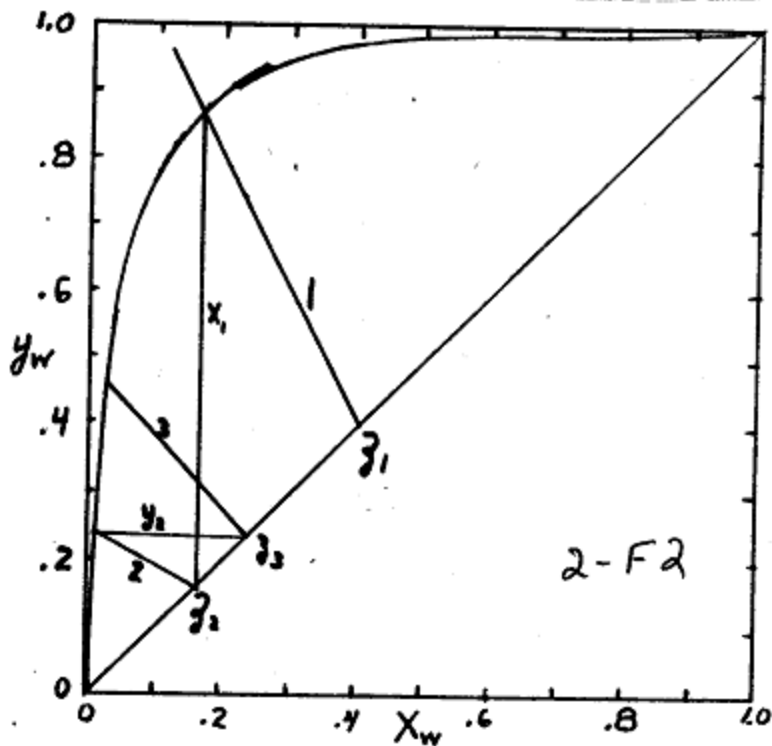

Stage 1)  $z_{F_1} = .4$   $f = 1/3$  Slope  $= -\frac{2/3}{1/3} = -2,$

Intercept  $= \frac{.4}{1/3} = 1.2$   $y_1 = .872$   $x_1 = .164 = z_2$

Stage 2)  $z_{F_2} = .164$   $f = 2/3$  Slope  $= -\frac{1/3}{2/3} = -1/2$

Intercept  $= \frac{.164}{2/3} = .246$   $x_2 \approx .01$   $y_2 = .240 = -z_3$

Stage 3)  $z_{F_3} = .240$   $f = 1/2$  Slope  $= -1$

Intercept  $= \frac{.240}{1/2} = .480$   $x_3 \approx .022$   $y_3 = .461$

2.F3. *Bubble Pt.* At  $P = 250$  kPa. Want  $\sum K_1 z_1 = 1$ . Solution uses DePriester chart for  $K$  values.

Guess  $T = -18^\circ\text{C}$ ,  $K_1 = 1$ ,  $K_2 = .043$ ,  $K_3 = .00095$ ,  $\sum = .52$

Converge to  $T = 0^\circ\text{C}$

*Dew Pt. Calc.* Want  $\sum \frac{z_1}{K_1} = 1.0$

Try  $T = 0^\circ\text{C}$ ,  $K_1 = 1.93$ ,  $K_2 = 0.11$ ,  $K_3 = 0.0033$ ,  $\sum = 120.26$

Converge to  $T = 124^\circ\text{C}$ . This is a wide boiling feed.

$T_{\text{drum}}$  must be lower than  $95^\circ\text{C}$  since that is feed temperature.

First Trial: Guess  $T_{d,1} = 70^\circ\text{C}$ :  $K_1 = 7.8$ ,  $K_2 = 1.07$ ,  $K_3 = .083$

Guess  $V/F = 0.5$ . Rachford Rice Eq.

$$f V/F = \frac{(7.8-1)(.517)}{1+(6.8)(.5)} + \frac{(.07)(.091)}{1+(.07)(.5)} + \frac{(.083-1)(.392)}{1+(.083-1)(.5)} = .14$$

$$V/F = .6 \text{ gives } f(.6) = -.101$$

By linear interpolation:  $V/F = .56$ .  $f(0.56) = -.0016$  which is close enough for first trial.

$$V = (V/F)F = 56, \quad L = 44$$

$$x_i = \frac{z_i}{1+(K_i-1)V/F} \text{ and } y_i = K_i x_i$$

$$x_1 = .1075 \quad x_2 = .088 \quad x_3 = .806 \quad \sum x = 1.001$$

$$y_1 = .839 \quad y_2 = .094 \quad y_3 = .067 \quad \sum y = .9999$$

Data: Pick  $T_{\text{ref}} = 25^\circ\text{C}$ . (Perry's 6<sup>th</sup> ed; p. 3-127), and (Perry's 6<sup>th</sup> ed; p. 3-138)

$$\lambda_1 = 81.76 \text{ cal/g} \times 44 = 3597.44 \text{ kcal/kmol}$$

$$\lambda_2 = 87.54 \text{ cal/g} \times 72 = 6302.88 \text{ kcal/kmol}$$

$$\lambda_3 = 86.80 \text{ cal/g} \times 114 = 9895.2 \text{ kcal/kmol}$$

at  $T = 0^\circ\text{C}$ ,  $C_{pL1} = 0.576 \text{ cal/(g }^\circ\text{C)} \times 44 = 25.34 \text{ kcal/(kmol }^\circ\text{C)}$ .

For  $T = 20 \text{ to } 123^\circ\text{C}$ ,  $C_{pL3} = 65.89 \text{ kcal/(kmol }^\circ\text{C)}$

at  $T = 75^\circ\text{C}$ ,  $C_{pL2} = 39.66 \text{ kcal/(kmol }^\circ\text{C)}$ . (Himmelblau/Appendix E-7)

$$C_{pv} = a + bT + cT^2$$

$$\text{propane} \quad a = 16.26 \quad b = 5.398 \times 10^{-2} \quad c = -3.134 \times 10^{-5}$$

$$\text{n-pentane} \quad a = 27.45 \quad b = 8.148 \times 10^{-2} \quad c = -4.538 \times 10^{-5}$$

$$\text{**n-octane} \quad a = 8.163 \quad b = 140.217 \times 10^{-3} \quad c = -44.127 \times 10^{-6}$$

\*\* Smith & Van Ness p. 106

$$\text{Energy Balance: } E(T_d) = VH_v + Lh_L - Fh_F = 0$$

$$Fh_F = 100[(.577)(25.34) + (.091)(39.66) + .392(65.89)](95.25) = 297,773 \text{ kcal/h}$$

$$Lh_L = 44[(.1075)(25.34) + (.088)(39.66) + (.806)(65.89)](70.25) = 117,450$$

$$\begin{aligned} VH_v = 56 & [ (.839)[3597.4 + 16.26 + 5.398 \times 10^{-2}(45)] \\ & + (.094)[6302.88 + 27.45 + 8.148 \times 10^{-2}(45)] \\ & + (.067)(9895.3 + 8.163 + 140.217 \times 10^{-3}(45)) ] = 240,423 \end{aligned}$$

$$E(T_{\text{drum}}) = -60,101 \text{ Thus, } T_{\text{drum}} \text{ is too high.}$$

Converge on  $T_{\text{drum}} = 57.2^\circ\text{C}$ :  $K_1 = 6.4$ ,  $K_2 = .8$ ,  $K_3 = .054$

For  $V/F = 0.513$ ,  $f(0.513) = -0.0027$ .  $V = 51.3$ ,  $L = 48.7$

$$x_1 = .137, \quad x_2 = .101, \quad x_3 = .762, \quad \sum x_i = 1.0000$$

$$y_1 = .878, \quad y_2 = .081, \quad y_3 = .041, \quad \sum y_i = 1.0000$$

$$Fh_F = 297,773; Lh_L = 90,459; VH_V = 209,999; E(T_{\text{drum}}) = +2685$$

Thus  $T_{\text{drum}}$  must be very close to  $57.3^\circ\text{C}$ .

$$x_1 = .136, x_2 = .101, x_3 = .762, y_1 = .328, y_2 = .081, y_3 = .041$$

$$V = 51.3 \text{ kmol/h}, L = 48.7 \text{ kmol/h}$$

Note: With different data  $T_{\text{drum}}$  may vary significantly.

2.F4. *New Problem 4<sup>th</sup> edition.* This is a mass and energy balance problem disguised as a flash distillation problem. Data is readily available in steam tables.. At 5000 kPa and 500K the feed is a liquid,  $h_F = 17.604 \text{ kJ/mol}$ . For an adiabatic flash,  $h_F = [VH_V + Lh_L]/F$

Vapor and liquid are in equilibrium. Saturated steam at 100 kPa is at  $T = 372.76\text{K}$ ,  $h_L = 7.5214 \text{ kJ/mol}$ ,  $H_V = 48.19 \text{ kJ/mol}$

Mass balance:  $F = V + L$  where  $F$  in  $\text{kmol/min} = (1500 \text{ kg/min})(1 \text{ kmol}/18.016 \text{ kg}) = 83.259 \text{ kmol/min}$

EB:  $Fh_F = VH_V + Lh_L \rightarrow$

$$(83.259 \text{ kmol/min})(17.604 \text{ kJ/mol})(1000 \text{ mol/kmol}) = (48.19)(1000)V + (7.5214)(1000)L.$$

Solve equations simultaneously.  $L = 62.617 \text{ kmol/min} = 1128.12 \text{ kg/min}$  and  $V = 20.642 \text{ kmol/min} = 371.88 \text{ kg/min}$

2.G1. Used Peng-Robinson for hydrocarbons.

$$\text{Find } T_{\text{drum}} = 33.13^\circ\text{C}, L = 34.82 \text{ and } V = 65.18 \text{ kmol/h}$$

In order ethylene, ethane, propane, propylene, n-butane,  $x_i (y_i)$  are:

$$0.0122(0.0748), 0.0866(0.3005), 0.3318(0.3781), 0.0306(0.0404), 0.5388(0.2062.)$$

2.G2. *New problem in 4<sup>th</sup> edition.* Part a.  $p = 31.26 \text{ kPa}$  with  $(V/F)_{\text{feed}} = 0.0009903$ .

Part b. Use  $p_{\text{feed}} = 31.76 \text{ kPa}$ ,  $(V/F)_{\text{feed}} = 0.0$

Part c. Drum  $p = 3.9 \text{ bar}$ ,  $T_{\text{drum}} = 19.339$ ,  $V/F = 0.18605$ ,

Liquid mole fractions:  $C1 = 0.14663$ ,  $C2 = 0.027869$  ( $\sum = 0.05253$  is in spec),  $C5 = 0.6171$ ,  $C6 = 0.3404$ .

Vapor mole fractions:  $C1 = 0.68836$ ,  $C2 = 0.20057$ ,  $C5 = 0.9523$ , and  $C6 = 0.01584$ .

2.G3. *New problem 4<sup>th</sup> edition.*  $K$  values in Aspen Plus are higher by 17.6% (methane), 7.04% (n-butane) and 0.07% n-pentane. Since the  $K$  values are higher  $V/F$  is higher by 10.2%.

Results:

	x	y	K
Methane	0.004599	0.27039	58.79
n-butane	0.44567	0.52474	1.1774
n-pentane	0.54973	0.20488	0.37269

$$(V/F)_{\text{drum}} = 0.43419; (V/F)_{\text{feed}} = 0.3654; Q = -3183.4 \text{ cal/s}$$

2.G4.

COMP	x(l)	y(l)
METHANE	0.12053E-01	0.84824
BUTANE	0.12978	0.78744E-01
PENTANE	0.29304	0.47918E-01
HEXANE	0.56513	0.25101E-01
V/F = 0.58354		

2.G5. *N.* Used NRTL.  $T = 368.07$ ,  $Q = 14889 \text{ kW}$ ,  $1^{\text{st}}$  liquid/total liquid = 0.4221,

Comp	Liquid 1, $x_1$	Liquid 2, $x_2$	Vapor, y
------	-----------------	-----------------	----------

Furfural	0.630	0.0226	0.0815
Water	0.346	0.965	0.820
Ethanol	0.0241	0.0125	0.0989

2.G6. Used Peng Robinson. Feed pressure = 10.6216 atm, Feed temperature = 81.14°C, V/F = 0.40001,  $Q_{\text{drum}} = 0$ . There are very small differences in feed temperature with different versions of AspenPlus.

COMP	x(I)	y(I)
METHANE	0.000273	0.04959
BUTANE	0.18015	0.47976
PENTANE	0.51681	0.39979
HEXANE	0.30276	0.07086
V/F = 0.40001		

2.H1. *New Problem 4<sup>th</sup> ed* A. 563.4 R, b.V/F = .4066. c. 18.264 psia

2.H3. *New Problem. 4<sup>th</sup> ed.* Answer V/F = 0.564;  $x_E = 0.00853$ ,  $x_{\text{hex}} = 0.421$ ,  $x_{\text{hept}} = .570$ ;  $y_E = .421$ ,  $y_{\text{Hex}} = 0.378$ ,  $y_{\text{Hept}} = .201$ .

2H4. *New Problem, 4<sup>th</sup> ed.* Answer:  $p_{\text{drum}} = 120.01$ , kPa = 17.40 psia  
 $x_B = 0.1561$ ,  $x_{\text{pen}} = 0.4255$ ,  $x_{\text{hept}} = 0.4184$ ,  $y_B = 0.5130$ ,  $y_{\text{Pen}} = 0.4326$ ,  $y_{\text{hept}} = 0.0544$

2H5. *New problem 4<sup>th</sup> ed.*

- SOLUTION. P = 198.52 kPa.
- V/F = 0.24836, ethane  $x = 0.00337$ ,  $y = 0.0824$ ; Propane  $x = 0.05069$ ,  $y = 0.3539$ ;  
 Butane  $x = 0.1945$ ,  $y = 0.3536$ ; Pentane  $x = 0.3295$ ,  $y = 0.1584$ ; Hexane  $x = 0.3198$ ,  $y = 0.0469$   
 Heptane  $x = 0.1022$ ,  $y = 0.00464$
- T = 34.48°C
- T = -1.586°C and V/F = 0.0567

2H6. New problem in 4<sup>th</sup> ed.

C2.H6

	A	B	C	D	E	F	G	H	I	J
1										
2	Example 2-2 on spreadsheet									
3	K1	7 K2		2.4 K3		0.8 K4		0.3		
4	z1	0.3 z2		0.1 z3		0.15 z4		0.45		
5	Guess V/F	0.500823								
6	x1	0.074908	x2	0.058784	x3	0.166697	x4	0.692922		
7	y1	0.524353	y2	0.141081	y3	0.12	y4	0.207877	sum ↓	
8	yk-xi	0.449445		0.082297		-0.0467		-0.48505	-2.1E-07	
9								chk	-0.00021	
10	Goal seek 9I to zero by changing B5									
11										