

1 Introduction

1.1 Exercise Solutions

Exercise 1–1. Given the pattern in the statement $1 \text{ k}\Omega = 1 \text{ kilohm} = 1 \times 10^3 \text{ ohms}$, fill in the blanks in the following statements using the standard decimal prefixes.

- 10^{-3} is milli or m. $5.0 \text{ mA} = 5 \text{ milliamperes} = 5 \times 10^{-3} \text{ amperes}$.
- d is deci or 10^{-1} . $10.0 \text{ dB} = 10.0 \text{ decibels} = 1.0 \text{ bel}$.
- p is pico or 10^{-12} . $3.6 \text{ ps} = 3.6 \text{ picoseconds} = 3.6 \times 10^{-12} \text{ seconds}$.
- micro is 10^{-6} or μ . Since we have less than one microfarad, we can also find expressions in terms of nanofarads with n being 10^{-9} . $0.03 \mu\text{F}$ or $30 \text{ nF} = 30 \text{ nanofarads} = 30.0 \times 10^{-9} \text{ farads}$.
- 10^9 is giga or G. $6.6 \text{ GHz} = 6.6 \text{ gigahertz} = 6.6 \times 10^9 \text{ hertz}$.

Exercise 1–2. A device dissipates 100 W of power. How much energy is delivered to it in 10 seconds ?

Energy is the product of power and time. In this case, we have $w = pt = 100 \text{ W} \times 10 \text{ s} = 1000 \text{ J} = 1 \text{ kJ}$.

Exercise 1–3. The graph in Figure 1–2(a) shows the charge $q(t)$ flowing past a point in a wire as a function of time.

- Find the current $i(t)$ at $t = 1, 2.5, 3.5, 4.5,$ and 5.5 ms . Current is the time rate of change of charge, $i = \frac{dq}{dt}$. For each time, compute the slope of the plot and account for the units. At 1 s , we have $i = \frac{-20 \text{ pC}}{2 \text{ ms}} = -10 \text{ nA}$. Similarly, for the other times, we have $+40 \text{ nA}, 0 \text{ nA}, -20 \text{ nA},$ and 0 nA .
- Sketch the variation of $i(t)$ versus time. The variations in $i(t)$ are shown in Figure 1–2(b) in the textbook and the plot is repeated below.

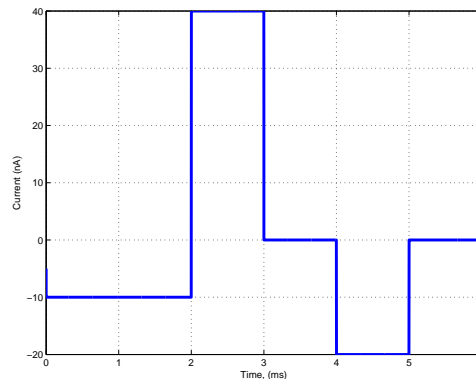

Exercise 1–4. The working variables of a set of two-terminal electrical devices are observed to be as follows:

	Device 1	Device 2	Device 3	Device 4	Device 5
v	+10 V	?	-15 V	+5 V	?
i	-3 A	-3 A	+10 mA	?	-12 mA
p	?	+40 W	?	+10 mW	-120 mW

Device 1: $p = vi = -30 \text{ W}$ (delivering power).

Device 2: $v = p/i = -13.3 \text{ V}$ (absorbing power).

Device 3: $p = vi = -150 \text{ mW}$ (delivering power).

Device 4: $i = p/v = +2 \text{ mA}$ (absorbing power).

Device 5: $v = p/i = +10 \text{ V}$ (delivering power).

1.2 Problem Solutions

Problem 1–1. Express the following quantities to the nearest standard prefix using no more than three digits.

- (a) $520,000,000 \text{ Hz} = 520 \times 10^6 \text{ Hz} = 520 \text{ MHz}$
- (b) $10,250 \text{ W} = 10.3 \times 10^3 \text{ W} = 10.3 \text{ kW}$
- (c) $0.333 \times 10^{-11} \text{ s} = 3.33 \times 10^{-12} \text{ s} = 3.33 \text{ ps}$
- (d) $33 \times 10^{-7} \text{ F} = 3.3 \times 10^{-6} \text{ F} = 3.3 \mu\text{F}$

Problem 1–2. Express the following quantities to the nearest standard prefix using no more than three digits.

- (a) $0.0022 \text{ H} = 2.2 \times 10^{-3} \text{ H} = 2.2 \text{ mH}$
- (b) $50.7 \times 10^5 \text{ J} = 5.07 \times 10^6 \text{ J} = 5.07 \text{ MJ}$
- (c) $82.251 \times 10^4 \text{ C} = 823 \times 10^3 \text{ C} = 823 \text{ kC}$
- (d) $5,633 \Omega = 5.63 \times 10^3 \Omega = 5.63 \text{ k}\Omega$

Problem 1–3. An ampere-hour (Ah) meter measures the time-integral of the current in a conductor. During an 8-hour period, a certain meter records 4500 Ah. Find the number of coulombs that flowed through the meter during the recording period.

By definition, 1 ampere = 1 coulomb/second and 1 hour = 3600 seconds. So $4500 \text{ Ah} = 4500 \text{ ampere-hour} = 4500 \text{ (coulomb/second)(hour)(3600 second/hour)} = 16.2 \text{ MC}$.

Problem 1–4. Fill in the blanks in the following statements.

- (a) To convert capacitance from nanofarads to microfarads, multiply by 10^{-3} . We have $1 \text{ nF} = 1 \times 10^{-9} \text{ F} = (1 \times 10^{-3}) \times 10^{-6} \text{ F} = 1 \times 10^{-3} \mu\text{F}$.
- (b) To convert resistance from megohms to kilohms, multiply by 10^3 . We have $1 \text{ M}\Omega = 1 \times 10^6 \Omega = (1 \times 10^3) \times 10^3 \Omega = 1 \times 10^3 \text{ k}\Omega$.
- (c) To convert voltage from millivolts to volts, multiply by 10^{-3} . We have $1 \text{ mV} = 1 \times 10^{-3} \text{ V}$.
- (d) To convert frequency from megahertz to gigahertz, multiply by 10^{-3} . We have $1 \text{ MHz} = 1 \times 10^6 \text{ Hz} = (1 \times 10^{-3}) \times 10^9 \text{ Hz} = 1 \times 10^{-3} \text{ GHz}$.

Problem 1–5. Place in increasing value the following:

- (a) $1500 \text{ m}\Omega$
- (b) 0.1632Ω
- (c) 1.444Ω
- (d) $0.0000016 \text{ M}\Omega$

Convert all of the values to ohms.

$$1500 \text{ m}\Omega = 1500 \times 10^{-3} \Omega = 1.5 \Omega$$

$$0.1632 \Omega = 0.1632 \Omega$$

$$1.444 \Omega = 1.444 \Omega$$

$$0.0000016 \text{ M}\Omega = 0.0000016 \times 10^6 \Omega = 1.6 \Omega$$

In ascending order, the values are 0.1632Ω , 1.444Ω , 1.5Ω , and 1.6Ω .

Problem 1-6. The net positive charge flowing through a device is $q(t) = 20 + 4t$ mC. Find the current through the device.

The current through the device is the derivative of the charge, $i = dq/dt$.

$$i = \frac{dq}{dt} = \frac{d}{dt}(20 + 4t) \text{ mC} = 4 \text{ mA}$$

The following MATLAB code calculates the same answer.

```
syms t real
qt = 20 + 4*t;
it = diff(qt,t)
```

Problem 1-7. Figure P1-7 shows a plot of the net positive charge flowing in a wire versus time. Sketch the corresponding current during the same period of time.

Take the derivative of the charge waveform to find the current. The charge waveform is piecewise linear, so calculate the slope of each segment to find the current values. The following table presents the results.

Start Time (s)	Stop Time (s)	Start Charge (C)	End Charge (C)	Current (A)
0	1	10	30	+20
1	2	30	0	-30
2	4	0	-20	-10
4	6	-20	30	+25

The following MATLAB code plots the original charge waveform and the corresponding current.

```
syms t
qt = (10+20*t)*(heaviside(t)-heaviside(t-1))...
+ (60-30*t)*(heaviside(t-1)-heaviside(t-2))...
+ (20-10*t)*(heaviside(t-2)-heaviside(t-4))...
+ (-120+25*t)*(heaviside(t-4)-heaviside(t-6));
tt = 0.001:0.01:6;
qtt = subs(qt,t,tt);
figure; plot(tt,qtt,'b','LineWidth',3)
xlabel('Time (s)'); ylabel('Charge (C)')
grid on

it = diff(qt,t);
itt = subs(it,t,tt);
figure; plot(tt,itt,'g','LineWidth',3)
xlabel('Time (s)'); ylabel('Current (A)')
grid on; axis([0 6 -40 40])
```

The resulting plots are shown below.

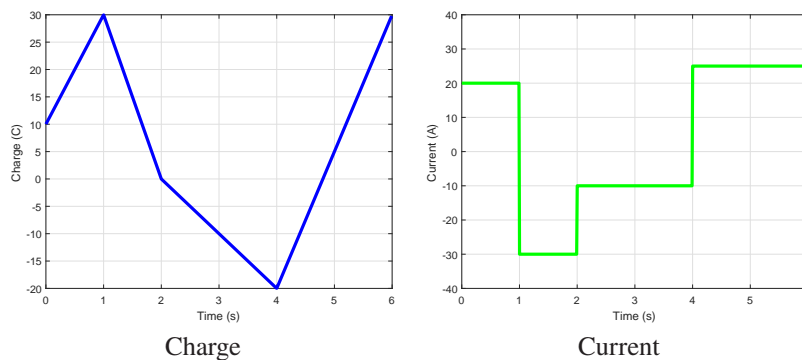

Problem 1–8. The net negative charge flowing through a device varies as $q(t) = 2.2t^2$ C. Find the current through the device at $t = 0$ s, $t = 0.5$ s, and $t = 1$ s.

The current is the derivative of the charge with respect to time, $i = dq/dt$.

$$i(t) = \frac{dq}{dt} = \frac{d}{dt}(2.2t^2) \text{ C} = 4.4t \text{ A}$$

Evaluate $i(t)$ at 0, 0.5, and 1 s to find the corresponding currents. We have $i(0) = 0$ A, $i(0.5) = 2.2$ A, and $i(1) = 4.4$ A. Note that since the negative charge is specified in the problem statement, the current flows in the opposite direction as the charge flow.

The following MATLAB code calculates the same answer.

```
syms t
qt = 2.2*t^2;
it = diff(qt,t)
tt = [0, 0.5, 1];
itt = subs(it,t,tt)
```

Problem 1–9. The charge flowing through a device is $q(t) = 1 - e^{-1000t}$ μC . What will the current be after 1.6094 ms?

The current is the derivative of the charge with respect to time, $i(t) = \frac{d}{dt}q(t)$. Compute the current as a function of time and then substitute the given time value.

$$i(t) = \frac{d}{dt}q(t) = \frac{d}{dt}(1 - e^{-1000t} \mu\text{C}) = (1000)e^{-1000t} \mu\text{A}$$

Substitute $t = 1.6094$ ms:

$$i(t) = (1000)e^{(-1000)(0.0016094)} \mu\text{A} = 200 \mu\text{A}$$

The following MATLAB code calculates the same answer.

```
syms t
qt = 1e-6*(1-exp(-1000*t));
it = diff(qt,t)
itt = double(subs(it,t,1.6094e-3))
```

Problem 1–10. The 12-V automobile battery in Figure P1–10 has an output capacity of 100 ampere-hours (Ah) when connected to a head lamp that absorbs 200 watts of power. The car engine is not running and therefore not charging the battery. Assume the battery voltage remains constant.

- (a) Find the current supplied by the battery and determine how long can the battery power the headlight.

The current is the power divided by the voltage, $i = p/v = 200 \text{ W}/12 \text{ V} = 16.667$ A. Divide the capacity of the battery by the current to determine how long the battery will power the headlight, $t = 100 \text{ Ah}/16.667 \text{ A} = 6$ hours.

- (b) A 100 W device is connected through the utility port. How long can the battery power both the headlight and the device?

The current is the power divided by the voltage, $i = p/v = (200 + 100) \text{ W}/12 \text{ V} = 25$ A. Note that the power requirement increased by 50%, so the current increased by 50% as well. Divide the capacity of the battery by the current to determine how long the battery will power the headlight and the extra device, $t = 100 \text{ Ah}/25 \text{ A} = 4$ hours.

The following MATLAB code calculates the same answers.

```
v = 12;
p = 200;
i = p/v
cap = 100;
t = cap/i

p2 = p+100;
i2 = p2/v
t2 = cap/i2
```

Problem 1–11. The current through a device is zero for $t < 0$ and is $i(t) = 5e^{-3t}$ A for $t \geq 0$. Find the charge $q(t)$ flowing through the device for $t \geq 0$.

The charge flowing through the device is the integral of the current over time.

$$q(t) = \int_0^t i(\tau) d\tau = \int_0^t 5e^{-3\tau} d\tau = -\frac{5}{3}e^{-3\tau} \Big|_0^t = -\frac{5}{3}(e^{-3t} - 1) = \frac{5}{3}(1 - e^{-3t}) \text{ C}, \quad t \geq 0$$

The following MATLAB code calculates the same answer.

```
syms t tau
it = 5*exp(-3*t);
itau = subs(it, t, tau)
qt = simple(int(itau, tau, 0, t))
```

Problem 1–12. When illuminated the i - v relationship for a photocell is $i = e^v - 10$ A. For $v = -2, 1$ and 2.5 V, find the device power and state whether it is absorbing or delivering power.

For each voltage, substitute into the expression for current and solve for the current. Multiply the current and voltage to find power. If the power is positive, the photocell is absorbing power. If the power is negative, the photocell is delivering power. The following table summarizes the results of the calculations.

v (V)	i (A)	p (W)	Absorbing/Delivering
-2	-9.8647	19.7293	Absorbing
1	-7.2817	-7.2817	Delivering
2.5	2.1825	5.4562	Absorbing

The following MATLAB code calculates the same answer.

```
v = [-2 1 2.5]
iv = exp(v)-10
p = v.*iv
pAbsorbs = p>0
Results = [v' iv' p' pAbsorbs']
```

Problem 1–13. The maximum current allowed by a device's power rating is limited by a 25 mA fuse. When the device is connected to a 9-V source what is the maximum power the device can dissipate?

Power is the product of voltage and current, $p = vi$. The maximum power will be the maximum current times the voltage, $p_{\text{Max}} = (9 \text{ V})(25 \text{ mA}) = 225 \text{ mW}$.

Problem 1–14. Traffic lights are being converted from incandescent bulbs to LED arrays to save operating and maintenance costs. Typically each incandescent light uses three 100-W bulbs, one for each color R, Y, G. A competing LED array consists of 61 LEDs with each LED requiring 9 V and drawing 20 mA of current. There are three arrays per light - R, Y, G. A small city has 2560 traffic signals. Since one light is always on 24/7, how much can a city save in one year if the city buys their electricity at 9.2 cents per kWh?

To solve this problem, compare two lights and then scale the problem to the number of lights in the city. The incandescent light always has on one 100-W bulb operating 24 hours per day for 365 days, which yields a total of 876 kWh at a cost of \$80.592. The LED light always has on one array, using a total power of $(61)(9\text{ V})(20\text{ mA}) = 10.98\text{ W}$. Over one year, the LED lights uses 96.185 kWh of energy at a cost of \$8.849. The savings per light per year is \$71.743, which, for a total of 2560 lights, translates into a city-wide saving of \$183,662 per year. The following MATLAB code calculates the same answer.

```
p_incand = 100/1000; % Incandescent power in kW
rate = 0.092; % Dollars per kWh
hours = 24*365; % Hours per year
cost_incand = p_incand*hours*rate

v_led = 9; % LED voltage
i_led = 20e-3; % LED current
n_led = 61; % Number of LED lights per array
p_led = n_led*v_led*i_led/1000 % Power in kW
cost_led = p_led*hours*rate

savings_light = cost_incand - cost_led
lights = 2560;
savings_year = lights*savings_light
```

Problem 1–15. Two electrical devices are connected as shown in Figure P1-15. Using the reference marks shown in the figure, find the power transferred and state whether the power is transferred from A to B or B to A when

- $v = +12\text{ V}$ and $i = -1.2\text{ A}$
- $v = +80\text{ V}$ and $i = +10\text{ mA}$
- $v = -240\text{ V}$ and $i = -12\text{ mA}$
- $v = -15\text{ V}$ and $i = -300\text{ }\mu\text{A}$

The passive sign convention applies to Element B, so if the power is positive the transfer is from A to B, and if the power is negative, the transfer is from B to A. For each case, calculate the power $p = vi$ and determine the direction of the power flow.

The following table summarizes the results of the calculations.

Case	v	i	p	Power Transfer
(a)	+12 V	-1.2 A	-14.4 W	B to A
(b)	+80 V	+10 mA	+800 mW	A to B
(c)	-240 V	-12 mA	+ 2.88 W	A to B
(d)	-15 V	-300 μA	+4.5 mW	A to B

The following MATLAB code calculates the same answer.

```
v = [12 80 -240 -15];
i = [-1.2 10e-3 -12e-3 -300e-6];
p = v.*i
AtoB = p>0
Results = [v' i' p' AtoB']
```

Problem 1–16. Figure P1–16 shows an electric circuit with a voltage and a current variable assigned to each of the six devices. The device voltages and currents are observed to be

	v (V)	i (A)
Device 1	15	–1
Device 2	5	1
Device 3	10	2
Device 4	–10	–1
Device 5	20	–3
Device 6	20	2

Find the power associated with each device and state whether the device is absorbing or delivering power. Use the power balance to check your work.

The power associated with each device is the product of the voltage and current, $p = vi$. If the power is positive, the device is absorbing power. If the power is negative, the device is delivering power. The original table is expanded below to include power and the direction of power flow.

	v (V)	i (A)	p (W)	Absorbing/Delivering
Device 1	15	–1	–15	Delivering
Device 2	5	1	5	Absorbing
Device 3	10	2	20	Absorbing
Device 4	–10	–1	10	Absorbing
Device 5	20	–3	–60	Delivering
Device 6	20	2	40	Absorbing

For the power to balance in this system, the sum of the individual device powers should be zero. We have $-15 + 5 + 20 + 10 - 60 + 40 = 0$, so the power balances.

The following MATLAB code calculates the same results.

```
v = [15 5 10 -10 20 20];
i = [-1 1 2 -1 -3 2];
p = v.*i
Absorbing = p>0
Balance = sum(p)
Results = [v' i' p' Absorbing']
```

Problem 1–17. Figure P1–16 shows an electric circuit with a voltage and a current variable assigned to each of the six devices. Use power balance to find v_4 when $v_1 = 20$ V, $i_1 = -2$ A, $p_2 = 20$ W, $p_3 = 10$ W, $i_4 = 1$ A, and $p_5 = p_6 = 2.5$ W. Is device 4 absorbing or delivering power?

First, calculate the power associated with device 1, $p_1 = v_1 i_1 = -40$ W. The power must balance in the circuit, so the sum of all of the device powers is zero. Therefore, we can solve for p_4 and v_4 as follows:

$$p_4 = -p_1 - p_2 - p_3 - p_5 - p_6 = 40 - 20 - 10 - 2.5 - 2.5 = 5 \text{ W}$$

$$v_4 = p_4 / i_4 = 5 / 1 = 5 \text{ V}$$

The power is positive, so the device is absorbing power.

Problem 1–18. An ion implanter is used to accelerate electrons to crash into a silicon wafer to study the effects of electron radiation damage on the devices on the wafer. If the beam carries 10^{15} electrons per second and is accelerated by a 350 kV source, find the current and power in the beam.

We can find the magnitude of the current by multiplying the magnitude of the charge of an electron q_E by the rate of electron flow dn_E/dt .

$$i = |q_E| \frac{dn_E}{dt} = (1.6 \times 10^{-19}) (10^{15}) = 1.6 \times 10^{-4} \text{ A} = 160 \mu\text{A}$$

Therefore, the beam power is

$$p = vi = (350 \times 10^3) (1.6 \times 10^{-4}) = 56 \text{ W}$$

Problem 1–19. Repeat Problem 1–16 using MATLAB to perform the calculations. Create a vector for the voltage values, $v = [15 \ 5 \ 10 \ -10 \ 20 \ 20]$, and a vector for the current values, $i = [-1 \ 1 \ 2 \ -1 \ -3 \ 2]$. Compute the corresponding vector for the power values, p , using element-by-element multiplication (\cdot $*$) and then use the `sum` command to verify the power balance.

The following MATLAB code provides the solution.

```
device = [1 2 3 4 5 6];
v = [15 5 10 -10 20 20];
i = [-1 1 2 -1 -3 2];
p = v.*i
Absorbing = p>0
Balance = sum(p)
Results = [device' v' i' p' Absorbing']
```

The corresponding MATLAB output is shown below.

```
Balance =
    0.0000e+000
Results =
    1.0000e+000    15.0000e+000    -1.0000e+000    -15.0000e+000    0.0000e+000
    2.0000e+000     5.0000e+000     1.0000e+000     5.0000e+000     1.0000e+000
    3.0000e+000    10.0000e+000     2.0000e+000    20.0000e+000     1.0000e+000
    4.0000e+000   -10.0000e+000    -1.0000e+000    10.0000e+000     1.0000e+000
    5.0000e+000    20.0000e+000    -3.0000e+000   -60.0000e+000     0.0000e+000
    6.0000e+000    20.0000e+000     2.0000e+000    40.0000e+000     1.0000e+000
```

The power balance is zero, as expected, and the other results match those in Problem 1–22.

Problem 1–20. Power Ratio in dB (A). A stereo amplifier takes the output of a CD player, for example, and increases the power to an audible level. Suppose the output of the CD player is 25 mW and the desired audible output is 100 W per stereo channel, find the power ratio of the amplifier per channel in decibels (dB), where the power ratio in dB is

$$PR_{\text{dB}} = 10 \log_{10} \left(\frac{p_2}{p_1} \right)$$

The power values are given, so substitute into the equation for the power ratio and calculate.

$$PR_{\text{dB}} = 10 \log_{10} \left(\frac{p_2}{p_1} \right) = 10 \log_{10} \left(\frac{100}{0.025} \right) = 10 \log_{10} (4000) = (10)(3.602) = 36.02 \text{ dB}$$

Problem 1–21. AC to DC Converter (A). A manufacturer's data sheet for the converter in Figure P1-21 states that the output voltage is $v_{\text{dc}} = 12 \text{ V}$ when the input voltage $v_{\text{ac}} = 120 \text{ V}$. When the load draws a current $i_{\text{dc}} = 15 \text{ A}$ the input power is $p_{\text{ac}} = 300 \text{ W}$. Find the efficiency of the converter.

The efficiency of the converter is the percentage of input power that is delivered to the load. The power delivered to the load is the product of the voltage and current, $p_{\text{Load}} = v_{\text{dc}} i_{\text{dc}} = (12 \text{ V})(15 \text{ A}) = 180 \text{ W}$. The power input to the converter is 300 W, so the efficiency is $(180 \text{ W})/(300 \text{ W}) = 60\%$.

Problem 1–22. Charge-Storage Device (A). A capacitor is a two-terminal device that can store electric charge. In a linear capacitor the amount of charge stored is proportional to the voltage across the device. For a particular device the proportionality is $q(t) = 10^{-7} v(t)$. If $v(t) = 0$ for $t < 0$ and $v(t) = 10(1 - e^{-5000t})$ for $t \geq 0$, find the energy stored in the device at $t = 100 \mu\text{s}$.

Take the derivative of the expression for charge to find the expression for current.

$$i(t) = \frac{d}{dt} [10^{-7} v(t)] = \frac{d}{dt} [10^{-6} (1 - e^{-5000t})] = 10^{-6} (5000 e^{-5000t}) = \frac{1}{200} e^{-5000t}$$

Multiply the expressions for voltage and current to find the expression for power.

$$p(t) = v(t) i(t) = [10(1 - e^{-5000t})] \left[\frac{1}{200} e^{-5000t} \right] = \frac{1}{20} (e^{-5000t} - e^{-10000t})$$

Integrate the power from $t = 0$ s to $t = 100 \mu\text{s}$ to determine the energy stored in the circuit.

$$\begin{aligned} w &= \int_0^{100 \mu\text{s}} p(t) dt = \int_0^{100 \mu\text{s}} \frac{1}{20} (e^{-5000t} - e^{-10000t}) dt \\ &= \frac{1}{20} \left(-\frac{e^{-5000t}}{5000} + \frac{e^{-10000t}}{10000} \right) \Bigg|_0^{100 \mu\text{s}} \\ &= \frac{1}{20} (-121.31 \times 10^{-6} + 200 \times 10^{-6} + 36.788 \times 10^{-6} - 100 \times 10^{-6}) = 774.09 \text{ nJ} \end{aligned}$$

The following MATLAB code calculates the same answer.

```
syms t
tt = 100e-6;
C = 1e-7;
vt = 10*(1-exp(-5000*t))
qt = C*vt
it = diff(qt,t)
pt = it*vt
wt = double(int(pt,t,0,tt))
```

The corresponding MATLAB output is shown below.

```
vt = 10 - 10*exp(-5000*t)
qt = 1/10000000 - exp(-5000*t)/10000000
it = exp(-5000*t)/200
pt = -(exp(-5000*t)*(10*exp(-5000*t) - 10))/200
wt = 774.0906e-009
```

Problem 1–23. Light Source Comparison (A). Today people have three competing light sources for home use. This problem asks you to determine the trade-offs between the costs of the three types of lights. In this example all three emit the same amount of light (lumens) or 1600 lumens. The following table shows the salient properties of each lamp. Over the lifetime of one light-emitting diode (LED) lamp, how much cost savings is there by using the LED lamp over the traditional incandescent bulb and over the compact fluorescent lamp (CFL) if electricity costs 10 cents/kWh?

Bulb Type	Cost per Lamp	Power Used	Average Lifetime
Incandescent	\$1.00	100 W	2500 Hrs
CFL	\$3.00	23 W	10,000 Hrs
LED	\$7.00	15 W	30,000 Hrs

Consider the LED lamp first. Purchase one LED lamp for \$7.00 and operate it for its lifetime of 30,000 hours. The energy used will be $(30000 \text{ hr})(15 \text{ W}) = 450 \text{ kWh}$ and the cost to operate it will be $(450 \text{ kWh})(\$0.10/\text{kWh}) = \45.00 . The total cost for the LED lamp is $\$7.00 + \$45.00 = \$52.00$.

For the incandescent bulb, determine the number of bulbs required to operate for the lifetime of one LED lamp by dividing the average lifetime of the LED lamp by the average lifetime of the incandescent bulb and rounding up, if necessary. The number of incandescent bulbs is $(30000/2500) = 12$, at cost of \$12.00. The energy used will be $(30000 \text{ hr})(100 \text{ W}) = 3000 \text{ kWh}$ and the cost to operate it will be $(3000 \text{ kWh})(\$0.10/\text{kWh}) = \300.00 . The total cost for the incandescent bulbs is $\$12.00 + \$300.00 = \$312.00$.

Perform a similar calculation for the CFL. The number of CFLs is $(30000/10000) = 3$, at cost of \$9.00. The energy used will be $(30000 \text{ hr})(23 \text{ W}) = 690 \text{ kWh}$ and the cost to operate it will be $(690 \text{ kWh})(\$0.10/\text{kWh}) = \69.00 . The total cost for the CFLs is $\$9.00 + \$69.00 = \$78.00$.

Comparing the three results, over its lifetime, the LED lamp saves \$260.00 over the incandescent bulbs and \$26.00 compared to the CFLs.

The following MATLAB code calculates the same answer.

```
% Given information
IncandLamp = 1;
IncandP = 100;
IncandLife = 2500;
CFLLife = 3;
CFLP = 23;
CFLLife = 10000;
LEDLamp = 7;
LEDP = 15;
LEDLife = 30000;
Cost_kWh = 0.1;

% Cost for incandescent
Incand_n = ceil(LEDLife/IncandLife);
IncandCost = Incand_n*IncandLamp + IncandP*LEDLife*Cost_kWh/1000

% Cost for CFL
CFL_n = ceil(LEDLife/CFLLife);
CFLCost = CFL_n*CFLLife + CFLP*LEDLife*Cost_kWh/1000

% Cost for LED
LED_n = 1;
LEDCost = LED_n*LEDLamp + LEDP*LEDLife*Cost_kWh/1000

% Savings
Saving_LED_Incand = IncandCost - LEDCost
Saving_LED_CFL = CFLCost-LEDCost
```

The corresponding MATLAB output is shown below.

```
IncandCost = 312
CFLCost = 78
LEDCost = 52
Saving_LED_Incand = 260
Saving_LED_CFL = 26
```

Problem 1–24. Ground Selection (D). A circuit consists of five voltages, namely, v_a , v_b , v_c , v_d , and v_e . The voltage from v_a to v_b is -5 V, from v_b to v_c is 10 V, from v_a to v_e is -2 V, and from v_b to v_d is 8 V.

- (a) If one wanted to eliminate negative voltages, which voltage would be best to select as ground?

We have the following voltage relationships:

$$v_a - v_b = -5 \text{ V}$$

$$v_b - v_c = 10 \text{ V}$$

$$v_a - v_e = -2 \text{ V}$$

$$v_b - v_d = 8 \text{ V}$$

If we pick $v_a = 0$ V and solve for the remaining voltages, we get:

$$v_b = v_a + 5 = 5 \text{ V}$$

$$v_c = v_b - 10 = -5 \text{ V}$$

$$v_d = v_b - 8 = -3 \text{ V}$$

$$v_e = v_a + 2 = 2 \text{ V}$$

To eliminate negative voltages, select the lowest voltage found in the scenario above to be the ground. Therefore, v_c is the ground.

- (b) What would all the remaining voltages be with your ground selection?

Set $v_c = 0$ V and solve for the other voltages.

$$v_b = v_c + 10 = 10 \text{ V}$$

$$v_a = v_b - 5 = 5 \text{ V}$$

$$v_d = v_b - 8 = 2 \text{ V}$$

$$v_e = v_a + 2 = 7 \text{ V}$$

None of the voltages are negative, as expected.

2 Basic Circuit Analysis

2.1 Exercise Solutions

Exercise 2–1. A 6-V lantern battery powers a light bulb that draws 3 mA of current. What is the resistance of the lamp? How much power does the lantern use?

Using Ohm's law, we have $v = iR$ or $R = \frac{v}{i}$, so we can compute the resistance as $R = \frac{6\text{ V}}{3\text{ mA}} = 2\text{ k}\Omega$. The power is $p = vi = (6\text{ V})(3\text{ mA}) = 18\text{ mW}$.

Exercise 2–2. What is the maximum current that can flow through a $\frac{1}{8}$ -W, 6.8-k Ω resistor? What is the maximum voltage that can be across it?

The resistor can dissipate up to 0.125 W of power. We have $p_{\text{MAX}} = i_{\text{MAX}}^2 R$, which we can solve for i_{MAX} and then substitute in values for the power and resistance

$$i_{\text{MAX}} = \sqrt{\frac{p_{\text{MAX}}}{R}} = \sqrt{\frac{0.125}{6800}} = 4.2875\text{ mA}$$

Similarly, we can use $p_{\text{MAX}} = \frac{v_{\text{MAX}}^2}{R}$ to solve for the maximum voltage as follows:

$$v_{\text{MAX}} = \sqrt{R p_{\text{MAX}}} = \sqrt{(6800)(0.125)} = 29.155\text{ V}$$

Exercise 2–3. A digital clock is a voltage that switches between two values at a constant rate that is used to time digital circuits. A particular clock switches between 0 V and 5 V every 10 μs . Sketch the clock's i - v characteristics for the times when the clock is at 0 V and at 5 V.

When the clock has a value of 0 V, its voltage is constant and zero for a wide range of currents. In this case, the i - v characteristic is a vertical line at 0 V. Likewise, when the clock has a value of 5 V, the voltage is constant at 5 V for a wide range of currents. In this case, the i - v characteristic is a vertical line at 5 V.

Exercise 2–4. Refer to Figure 2–12.

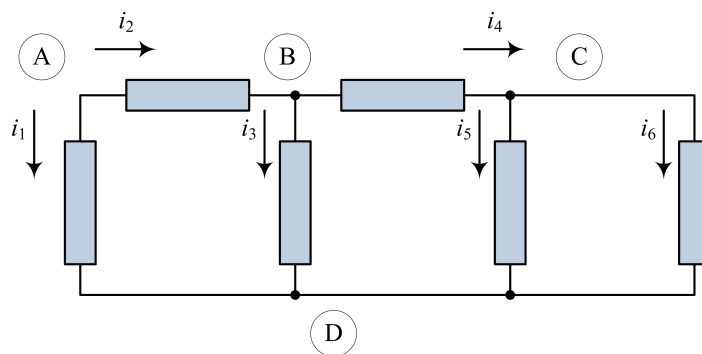

- (a) Write KCL equations at nodes A, B, C, and D.

KCL states that the sum of the currents entering a node is zero at every instant. As we sum the currents at a node, if the current enters that node, it is positive and if the current leaves the node, it is negative. At node A, both currents i_1 and i_2 are leaving the node, so the equation is $-i_1 - i_2 = 0$. At node B, current i_2 enters the node and currents i_3 and i_4 leave the node, so we have $i_2 - i_3 - i_4 = 0$. At node C, current i_4 enters the node and currents i_5 and i_6 leave the node, so we have $i_4 - i_5 - i_6 = 0$. At node D, currents i_1 , i_3 , i_5 , and i_6 enter the node, so we have $i_1 + i_3 + i_5 + i_6 = 0$.

- (b) Given $i_1 = -1\text{ mA}$, $i_3 = 0.5\text{ mA}$, $i_6 = 0.2\text{ mA}$, find i_2 , i_4 , and i_5 .

Applying the KCL equation for node A, we can find $i_2 = -i_1 = 1\text{ mA}$. Applying the KCL equation for node B, we have $i_4 = i_2 - i_3 = 1 - 0.5 = 0.5\text{ mA}$. Finally, applying the KCL equation for node C, we have $i_5 = i_4 - i_6 = 0.5 - 0.2 = 0.3\text{ mA}$.

(c) Identify which equation is redundant.

The equation at node D is redundant to those at nodes A, B, and C. If we sum the equations for nodes A, B, and C together and multiply the result by -1 , we can generate the equation for node D.

Exercise 2-5. Find the voltages v_x and v_y in Figure 2-14.

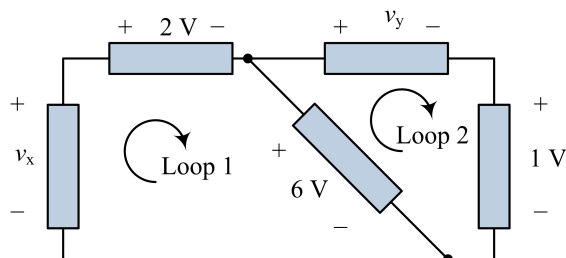

To find v_x , write the KVL equation around Loop 1 as $-v_x + 2 + 6 = 0$ and solve for $v_x = +8$ V. To find v_y , write the KVL equation around Loop 2 as $v_y + 1 - 6 = 0$ and solve for $v_y = +5$ V.

Exercise 2-6. Find the voltages v_x , v_y , and v_z in Figure 2-15.

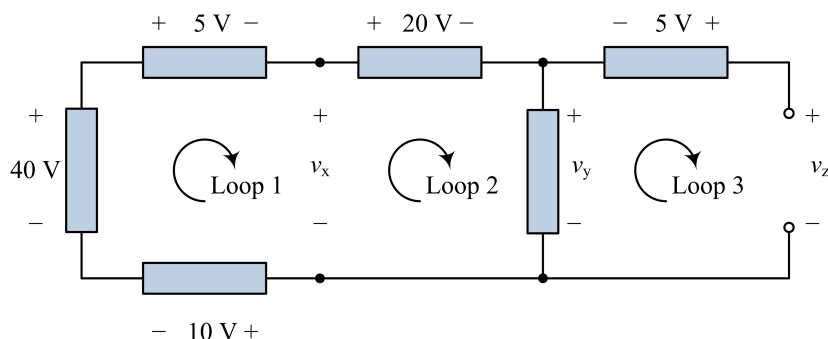

In Figure 2-15, some of the unknown voltages do not appear across elements, but we can still write KVL equations. For Loop 1 starting with the lowest element, the KVL equation is $10 - 40 + 5 + v_x = 0$, which can be solved to yield $v_x = 25$ V. For Loop 2, the KVL equation is $-v_x + 20 + v_y = 0$, which can be solved for $v_y = 25 - 20 = 5$ V. Finally, for Loop 3, the KVL equation is $-v_y - 5 + v_z = 0$, which yields $v_z = 5 + 5 = 10$ V.

Exercise 2-7. Identify the elements connected in series or parallel when a short circuit is connected between nodes A and B in each of the circuits in Figure 2-18. The modified circuits are shown below.

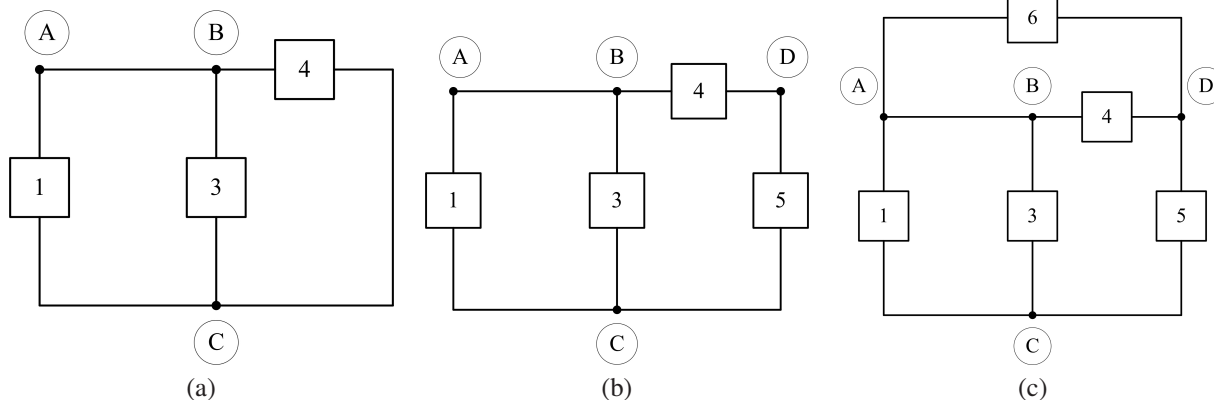

In the solution, the short circuit has been applied in each of the circuits and Element 2 has been shorted out of the circuit. For the circuit in Figure 2–18(a), all of the elements share the same two nodes, A and C, so Elements 1, 2, and 3 are in parallel. For the circuit in Figure 2–18(b), Elements 1 and 3 share nodes A and C, so they are in parallel. In addition, Elements 4 and 5 are the only elements connected to node D, so they are in series. For the circuit in Figure 2–18(c), Elements 1 and 3 are in parallel because they share nodes A and C. In addition, Elements 4 and 6 are in parallel, because they share nodes A and D.

Exercise 2–8. Identify the elements in Figure 2–19 that are connected in (a) parallel, (b) series, or (c) neither.

Refer to the figure in the textbook.

- (a) Elements 1, 8, and 11 share the upper left node and ground, so they are in parallel. In addition, Elements 3, 4, and 5 share the center node and ground, so they are in parallel.
- (b) Elements 9 and 10 are in series, because they share a single node and no other elements with current connect to that node. Likewise, Elements 6 and 7 share a single node with no other elements, so they are also in series.
- (c) The remaining element, Element 2, is neither in series nor in parallel with any other elements.

Exercise 2–9. A 1-k Ω resistor R_R is inserted between nodes A and B in Figure 2–20(a) as shown in Figure 2–20(b).

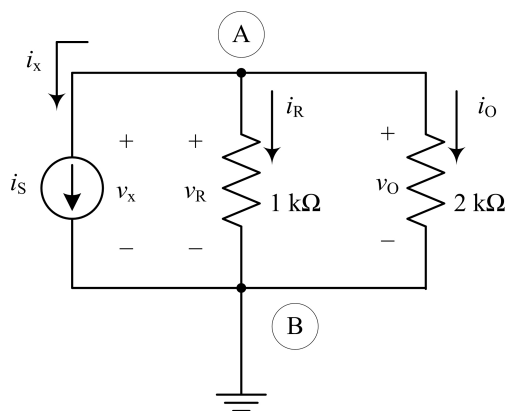

The voltage across it is labeled v_R and the current through it is labeled i_R . Write a set of element and connection constraints defining the circuit. Then find i_x , v_x , i_O , i_R , v_R , and v_O if $i_S = 1$ mA and $R = 2$ k Ω .

The resulting circuit is shown earlier. Note that the 1-k Ω resistor has been inserted and the current through it labeled as i_R and the voltage across it labeled as v_R . The element constraint for the current source is $i_S = i_x = 1$ mA. The element constraints for the resistors are $v_R = i_R R_R = 1000 i_R$ and $v_O = i_O R = 2000 i_O$. Writing KCL at the top node, we have $-i_S - i_R - i_O = 0$. Writing KVL around the left loop yields $-v_x + v_R = 0$. Writing KVL around the right loop yields $-v_R + v_O = 0$. Alternately, we can see that the three elements all share the top and bottom nodes, so they are all in parallel and have the same voltage, $v_x = v_R = v_O$. Using these equations we can solve for the unknown values

as follows:

$$\begin{aligned}
 i_x &= i_S = 1 \text{ mA} \\
 v_R &= v_O \\
 R_R i_R &= R_O i_O \\
 1000 i_R &= 2000 i_O \\
 i_R &= 2 i_O \\
 i_x + i_R + i_O &= 0 \\
 i_R + i_O &= -i_x = -1 \text{ mA} \\
 2 i_O + i_O &= -1 \text{ mA} \\
 3 i_O &= -1 \text{ mA} \\
 i_O &= -333 \mu\text{A} \\
 v_x = v_R = v_O &= (2 \text{ k}\Omega)(-333 \mu\text{A}) = -667 \text{ mV} \\
 i_R = 2 i_O &= -667 \mu\text{A}
 \end{aligned}$$

Exercise 2–10. The wire connecting R_1 to node B in Figure 2-21 is broken. What would you measure for i_A , v_1 , i_2 , and v_2 ? Is KVL violated? Where does the source voltage appear across?

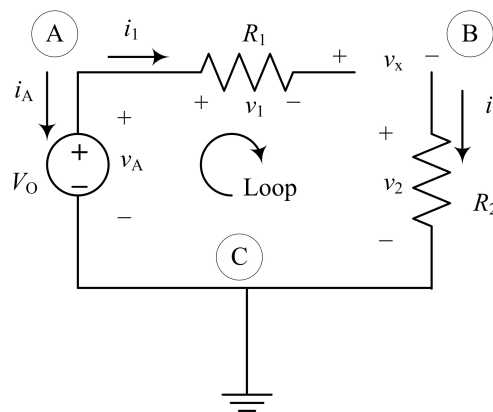

The resulting circuit is shown above. If the circuit is broken between R_1 and node B, then no current can flow in the circuit and all currents are zero, $i_A = i_1 = i_2 = 0$. Using Ohm's law, $v = Ri$, for the voltages across the resistors, the current is zero, so the voltages must also be zero and we have $v_1 = v_2 = 0$. Note that a new voltage, v_x , has been labeled across the gap where the circuit is broken. We can now write KVL as $-v_A + v_1 + v_x + v_2 = 0$. With $v_1 = v_2 = 0$, we get $v_x = v_A = V_O$. KVL is not violated because the voltage from the source now appears across the gap in the open (broken) circuit.

Exercise 2–11. Repeat the problem of Example 2-10 if the 30-V voltage source is replaced with a 2-mA current source with the arrow pointed up toward node A.

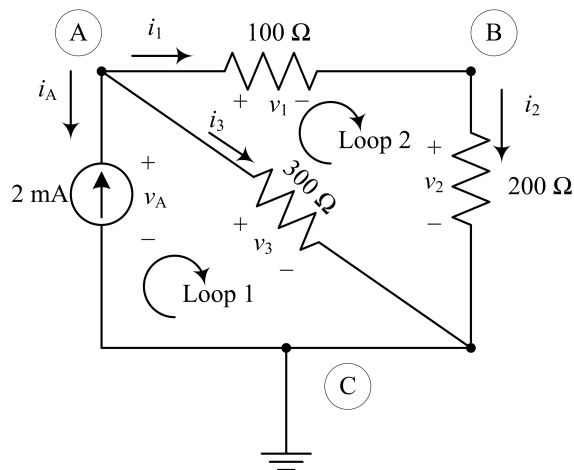

The resulting circuit is shown above. The description of the circuit requires four element equations and four connection equations. The element equations are

$$\begin{aligned}v_1 &= 100i_1 \\v_2 &= 200i_2 \\v_3 &= 300i_3 \\i_A &= -2\text{ mA}\end{aligned}$$

The four connection equations are

$$\begin{aligned}\text{KCL : Node A} & & -i_A - i_1 - i_3 &= 0 \\ \text{KCL : Node B} & & i_1 - i_2 &= 0 \\ \text{KVL : Loop 1} & & -v_A + v_3 &= 0 \\ \text{KVL : Loop 2} & & -v_3 + v_1 + v_2 &= 0\end{aligned}$$

The KCL equation at node B implies $i_1 = i_2$. We can then start with the KVL equation around loop 2 and solve as follows:

$$\begin{aligned}-v_3 + v_1 + v_2 &= 0 \\ v_1 + v_2 &= v_3 \\ 100i_1 + 200i_2 &= 300i_3 \\ 100i_1 + 200i_1 &= 300i_3 \\ 300i_1 &= 300i_3 \\ i_1 &= i_3\end{aligned}$$

Now using the KCL equation at node A, we have

$$\begin{aligned} -i_A - i_1 - i_3 &= 0 \\ i_1 + i_3 &= -i_A = 2 \text{ mA} \\ i_1 + i_1 &= 2 \text{ mA} \\ 2i_1 &= 2 \text{ mA} \\ i_1 &= i_3 = i_2 = 1 \text{ mA} \end{aligned}$$

Now apply Ohm's law to solve for the voltages

$$\begin{aligned} v_1 &= 100i_1 = 100 \text{ mV} \\ v_2 &= 200i_2 = 200 \text{ mV} \\ v_3 &= 300i_3 = 300 \text{ mV} \end{aligned}$$

Exercise 2–12. In Figure 2–24 write a loop equation around Loop 1 and a node equation at Node A. Then if $i_1 = 200$ mA and $i_3 = -100$ mA, use the appropriate element equations to find the voltages v_x and v_y .

Write the KVL equation around Loop 1 as $-v_x + v_1 + v_2 = 0$. The KCL equation at Node A is $i_1 - i_2 - i_3 = 0$. Solving for i_2 and substituting in the given values, we have $i_2 = i_1 - i_3 = 200 + 100 = 300$ mA. Apply Ohm's law to solve for $v_1 = 100i_1 = (100 \Omega)(200 \text{ mA}) = 20$ V, and $v_2 = 50i_2 = (50 \Omega)(300 \text{ mA}) = 15$ V. Solve for $v_x = v_1 + v_2 = 20 + 15 = 35$ V. Write a KVL equation around the right loop as $-v_2 + v_3 + v_y = 0$. Apply Ohm's law to find $v_3 = 200i_3 = (200 \Omega)(-100 \text{ mA}) = -20$ V. Solve for v_y as $v_y = v_2 - v_3 = 15 + 20 = 35$ V.

Exercise 2–13. In Figure 2–25(a), the 2-A source is replaced by a 100-V source with the + terminal at the top, and the 3-A source is removed. Find the current and its direction through the voltage source.

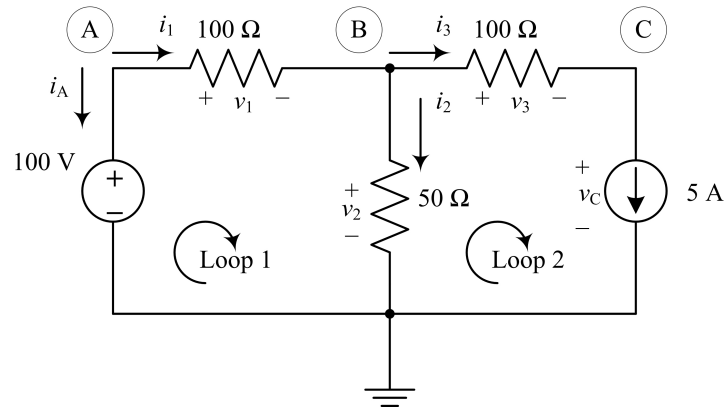

The resulting circuit is shown above. Writing KCL at node C, we have $i_3 - 5 = 0$, which yields $i_3 = 5$ A. Write the KCL equation at node B to get $i_1 - i_2 - i_3 = 0$, which can be solved for $i_1 = i_2 + i_3 = i_2 + 5$. Write the KVL equation around loop 1 to get $-100 + v_1 + v_2 = 0$, which yields the following

$$v_1 + v_2 = 100$$

$$100i_1 + 50i_2 = 100$$

$$100(i_2 + 5) + 50i_2 = 100$$

$$100i_2 + 500 + 50i_2 = 100$$

$$150i_2 = -400$$

$$i_2 = -2.667 \text{ A}$$

We can then solve for $i_1 = i_2 + 5 = 2.333$ A and $i_A = -i_1 = -2.333$ A. Since i_A is negative, the current follows in the opposite direction through the voltage source, which is up, and has a magnitude of 2.333 A.

Exercise 2–14. Find the equivalent resistance for the circuit in Figure 2–29.

Redraw the original circuit to an equivalent circuit without the diagonal resistor. Starting from the right side, combine resistors in series or parallel as appropriate to reduce the circuit to a single resistor. The following sequence of circuits shows the progress in reducing the circuit.

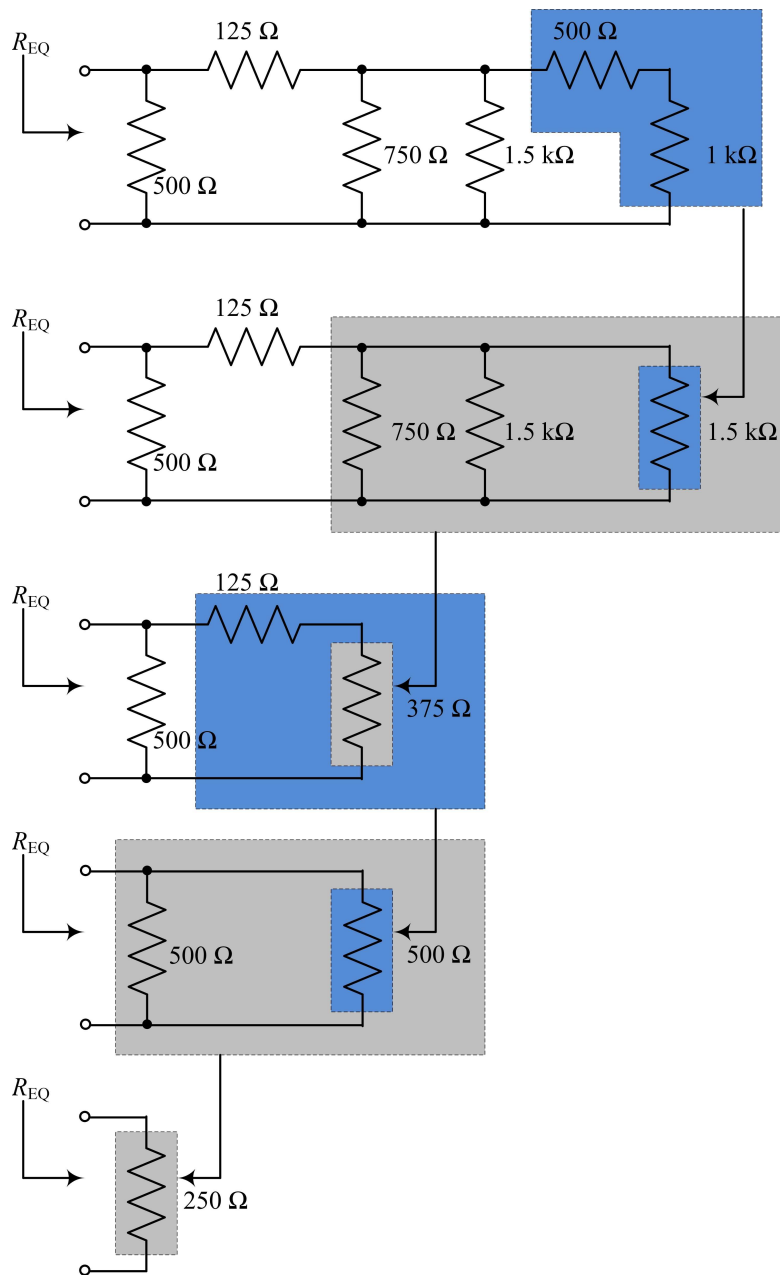

Starting at the far right, combine the $500\text{-}\Omega$ and $1\text{-k}\Omega$ resistors in series to get a $1.5\text{-k}\Omega$ resistor. Next, combine the two $1.5\text{-k}\Omega$ resistors and the $750\text{-}\Omega$ resistor in parallel to get a $375\text{-}\Omega$ resistor. Combine the $125\text{-}\Omega$ resistor in series with the $375\text{-}\Omega$ resistor to get a $500\text{-}\Omega$ resistor. Combine the two $500\text{-}\Omega$ resistors in parallel to get the final equivalent resistance of $250\ \Omega$.

Exercise 2–15. Find the equivalent resistance between terminals A–C, B–D, A–D, and B–C in the circuit in Figure 2–30.

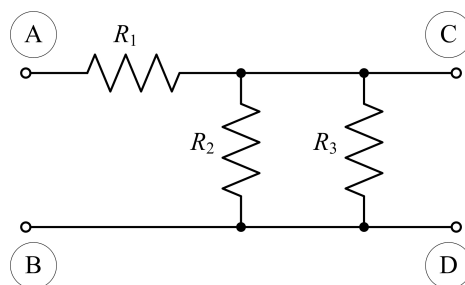

If current flows only between terminals A and C, then no current flows through terminals B and D and resistors R_2 and R_3 are not active in the circuit. The equivalent resistance $R_{A-C} = R_1$. If current flows only between terminals B and D, then no current flows through terminals A and C and none of the resistors are active in the circuit. The equivalent resistance $R_{B-D} = 0$. If current flows between terminals A and D, resistors R_2 and R_3 are in parallel and that combination is in series with R_1 . The equivalent resistance $R_{A-D} = R_1 + R_2 \parallel R_3 = R_1 + \frac{R_2 R_3}{R_2 + R_3}$. If current flows between terminals B and C, then no current flows through R_1 and it is not part of the circuit. The equivalent resistance is the parallel combination of R_2 and R_3 or $R_{B-C} = R_2 \parallel R_3 = \frac{R_2 R_3}{R_2 + R_3}$.

Exercise 2–16. Find the equivalent resistance between terminals A–B, A–C, A–D, B–C, B–D, and C–D in the circuit of Figure 2-31. For example: $R_{A-B} = (80 \parallel 80) + 60 = 100 \Omega$.

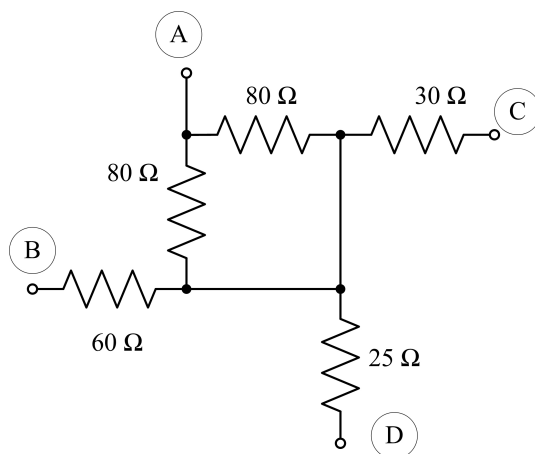

If current flows between terminals A and C, then no current flows through the 60- Ω and the 25- Ω resistors and they are not part of the circuit. The two 80- Ω resistors are in parallel and that combination is in series with the 30- Ω resistor, so we have $R_{A-C} = (80 \parallel 80) + 30 = 70 \Omega$. If current flows between terminals A and D, then no current flows through the 60- Ω and the 30- Ω resistors and they are not part of the circuit. Again, the two 80- Ω resistors are in parallel and that combination is in series with the 25- Ω resistor, so we have $R_{A-D} = (80 \parallel 80) + 25 = 65 \Omega$. If current flows between terminals B and C, then no current flows through the 25- Ω resistor and it is not part of the circuit. In addition, in the remaining circuit, the two 80- Ω resistors are shorted out. The resulting circuit is a series combination of the 60- Ω and 30- Ω resistors, which yields $R_{B-C} = 60 + 30 = 90 \Omega$. If current flows between terminals B and D, then no current flows through the 30- Ω resistor and it is not part of the circuit. In addition, in the remaining circuit, the two 80- Ω resistors are again shorted out. The resulting circuit is a series combination of the 60- Ω and 25- Ω resistors, which yields $R_{B-D} = 60 + 25 = 85 \Omega$. Finally, with current flowing between terminals C and D, the 60- Ω resistor is not part of the circuit and the two 80- Ω resistors are shorted out. The equivalent resistance is the series combination of the 30- Ω and 25- Ω resistors, which yields $R_{C-D} = 25 + 30 = 55 \Omega$.

Exercise 2–17. A practical current source consists of a 2-mA ideal current source in parallel with a 500- Ω resistance. (a) Find the equivalent practical voltage source. (b) Connect a 1-k Ω resistor in parallel with the first and find the power delivered by the current source. (c) Find the power delivered by the equivalent voltage source. Why is there a difference in the source powers?

- (a) The equivalent practical voltage source will have the same 500- Ω resistance. To transform the current source into a voltage source, we compute $v_S = i_S R = (2 \text{ mA})(500 \Omega) = 1 \text{ V}$. The equivalent practical voltage source is therefore a 1-V ideal voltage source in series with a 500- Ω resistor.
- (b) The ideal current source experiences an equivalent resistance of $500 \parallel 1000 = (500)(1000)/(500 + 1000) = 333 \Omega$. The voltage across the current source is $v_S = i_S R_{EQ} = (2 \text{ mA})(333 \Omega) = 666 \text{ mV}$. The power supplied by the current source is $p_S = i_S v_S = (2 \text{ mA})(666 \text{ mV}) = 1.33 \text{ mW}$.
- (c) The ideal voltage source experiences an equivalent resistance for $500 + 1000 = 1500 \Omega$. The current supplied by the voltage sources is $i_S = v_S/R = 1 \text{ V}/1500 \Omega = 667 \mu\text{A}$. The power supplied by the voltage source is $p_S = i_S v_S = (667 \mu\text{A})(1 \text{ V}) = 667 \mu\text{W}$. The sources provide different powers because equivalent circuits are only guaranteed to provide the same voltage, current, and power to the load, which is the 1-k Ω resistor in this case. The equivalent circuits may have different internal characteristics.

Exercise 2–18. Find the equivalent circuit for each of the following

- (a) Three ideal 1.5-V batteries connected in series.
For voltage sources connected in series, the voltages add. Assuming all three sources are oriented in the same direction, the equivalent voltage is $1.5 + 1.5 + 1.5 = 4.5 \text{ V}$.
- (b) A 5-mA current source in series with a 100-k Ω resistor.
A current source in series with a resistor acts as a current source without the resistor, so the equivalent circuit is a single 5-mA current source.
- (c) A 40-A ideal current source in parallel with an ideal 10-A current source.
For ideal current sources in parallel, the currents add, so the equivalent circuit is a 50-A current source.
- (d) A 100-V source in parallel with two 10-k Ω resistors.
A voltage source in parallel with any resistance acts like a voltage source, so the equivalent circuit is a single 100-V voltage source.
- (e) An ideal 15-V source in series with an ideal 10-mA source.
This is not a valid combination of sources and the two cannot be combined in a theoretical perspective.
- (f) A 15-V ideal source and a 5-V ideal source connected in parallel.
This is not a valid combination of voltage sources, since a parallel combination of elements must have the same voltage.

Exercise 2–19. Find the voltages v_x , v_y , and v_z in the circuit of Figure 2–39. Show that the sum of all the voltages across each of the individual resistors equals the source voltage.

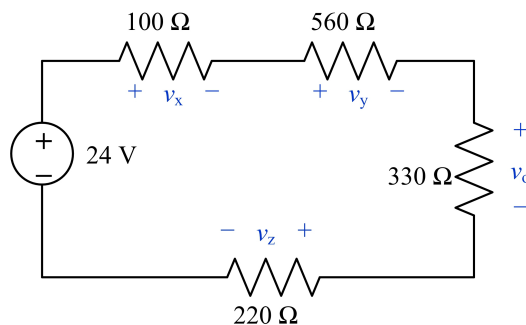

For each resistor, use voltage division to find its corresponding voltage.

$$v_x = \left(\frac{100}{100 + 560 + 330 + 220} \right) 24 = 1.9835 \text{ V}$$

$$v_y = \left(\frac{560}{100 + 560 + 330 + 220} \right) 24 = 11.1074 \text{ V}$$

$$v_o = \left(\frac{330}{100 + 560 + 330 + 220} \right) 24 = 6.5455 \text{ V}$$

$$v_z = \left(\frac{220}{100 + 560 + 330 + 220} \right) 24 = 4.3636 \text{ V}$$

Sum the voltages to get $1.9835 + 11.107 + 6.5455 + 4.3636 = 24 \text{ V}$, which matches the source voltage.

Exercise 2–20. Using only the available 10% tolerance resistors in the inside back cover, design a voltage divider to obtain $6.5 \text{ V} \pm 20\%$ from a 20-V source using only two resistors.

There are many valid designs to solve this problem. With only two resistors, we want one to have 6.5 V across it, which implies the other will have 13.5 V across it. The voltages have a ratio of approximately 1:2, so we want the resistors to have a similar ratio. We can calculate the exact ratio using the voltage divider equation as follows:

$$v_o = \frac{R_o}{R_s + R_o} v_{\text{TOTAL}}$$

$$6.5 = \frac{R_o}{R_s + R_o} (20)$$

$$\frac{R_o}{R_s + R_o} = 0.325$$

$$R_o - 0.325 R_o = 0.325 R_s$$

$$R_o = 0.481 R_s$$

Reviewing all of the resistor options in the table, the best match is $R_o = 2.7 \text{ k}\Omega$ and $R_s = 5.6 \text{ k}\Omega$, which have a ratio of 0.482. With these resistor choices, the output voltage is calculated as follows:

$$v_o = \frac{R_o}{R_s + R_o} v_{\text{TOTAL}} = \frac{2.7}{5.6 + 2.7} (20) = 6.506 \text{ V}$$

If the resistors approach the limits of their tolerances, the output voltage could vary between 5.66 V and 7.42 V, which is within the 20% tolerance for the output voltage of 6.5 V, or between 5.2 V and 7.8 V. Other good resistor options

include $R_O = 3.3 \text{ k}\Omega$ and $R_S = 6.8 \text{ k}\Omega$, which have a ratio of 0.485, or $R_O = 3.9 \text{ k}\Omega$ and $R_S = 8.2 \text{ k}\Omega$, which have a ratio of 0.476.

Exercise 2–21. In Figure 2-40, $R_x = 10 \text{ k}\Omega$. The output voltage $v_O = 20 \text{ V}$. Find the voltage source that would produce that output. (*Hint:* It is not 10 V.)

The modified circuit is shown below.

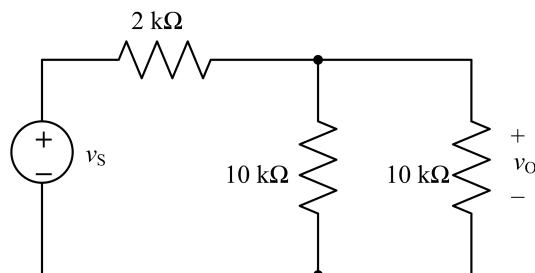

Combine the two 10-k Ω resistors in parallel to get a single 5-k Ω resistor in series with the 2-k Ω resistor. The 5-k Ω resistor still has 20 V across it. Use the voltage division equation to solve for the voltage of the source as follows:

$$20 = \left(\frac{5000}{5000 + 2000} \right) v_s$$

$$v_s = \left(\frac{5000 + 2000}{5000} \right) 20 = 28 \text{ V}$$

Exercise 2–22. In Figure 2–41, suppose that a resistor R_4 is connected across the output. What value should R_4 be if we want $\frac{1}{2}v_s$ to appear between node A and ground?

Using the concept of voltage division, for one-half of v_s to appear between node A and ground, the resistance between node A and ground will have to match R_1 so that the source voltage divides equally between the two parts of the circuit. The equivalent resistance between node A and ground is the series combination of R_3 and R_4 in parallel with R_2 or $R_{EQ} = R_2 \parallel (R_3 + R_4)$. Setting $R_{EQ} = R_1$ we can solve for R_4 as follows:

$$R_1 = R_2 \parallel (R_3 + R_4) = \frac{R_2(R_3 + R_4)}{R_2 + R_3 + R_4} = \frac{R_2 R_3 + R_2 R_4}{R_2 + R_3 + R_4}$$

$$R_1(R_2 + R_3 + R_4) = R_2 R_3 + R_2 R_4$$

$$R_1 R_4 - R_2 R_4 = R_2 R_3 - R_1 R_2 - R_1 R_3$$

$$R_4(R_1 - R_2) = R_2 R_3 - R_1 R_2 - R_1 R_3$$

$$R_4 = \frac{R_2 R_3 - R_1 R_2 - R_1 R_3}{R_1 - R_2} = \frac{R_1 R_3 + R_1 R_2 - R_3 R_2}{R_2 - R_1}$$

Exercise 2–23. Ten volts (v_s) are connected across the 10-k Ω potentiometer (R_{TOTAL}) shown in Figure 2–42(c). A load resistor of 10 k Ω is connected across its output. At what resistance should the wiper ($R_{TOTAL} - R_1$) be set so that 2 V appears at the output, v_O ?

To solve this problem, first define $R_2 = R_{TOTAL} - R_1$, which is the resistance we want to find. For a 10-k Ω potentiometer, $R_1 + R_2 = 10 \text{ k}\Omega$, so $R_1 = 10 \text{ k}\Omega - R_2$. The equivalent resistance of the output is $R_{EQ} = R_2 \parallel 10 \text{ k}\Omega$.

Now use the voltage division equation and the specified source and output voltages to solve for R_2 as follows:

$$2 = \left(\frac{R_{\text{EQ}}}{R_1 + R_{\text{EQ}}} \right) 10 = \left[\frac{\frac{10^4 R_2}{10^4 + R_2}}{10^4 - R_2 + \left(\frac{10^4 R_2}{10^4 + R_2} \right)} \right] 10$$

$$2 \left[10^4 - R_2 + \left(\frac{10^4 R_2}{10^4 + R_2} \right) \right] = \left(\frac{10^4 R_2}{10^4 + R_2} \right) 10$$

$$(10^4 - R_2)(10^4 + R_2) + 10^4 R_2 = (10^4 R_2)(5)$$

$$-R_2^2 + 10^8 + 10^4 R_2 = (5 \times 10^4)R_2$$

$$R_2^2 + (4 \times 10^4)R_2 - 10^8 = 0$$

Solving for the positive root of the quadratic equation, we get $R_2 = 2.36 \text{ k}\Omega$. The other root is negative, so it is not a valid solution for a resistance.

Exercise 2–24. For the circuit shown in Figure 2–43, find the values of the output v_O as the potentiometer is moved across its range. Then determine the value of v_O if the potentiometer is set to exactly halfway of its range.

If the wiper is set at the top of the 5-k Ω resistor, then the full voltage of the source appears across the output, which is 15 V. If the wiper is set at the bottom of the 5-k Ω resistor, there is no voltage drop across the output resistor and the output voltage is 0 V. The output voltage range is therefore $0 \text{ V} \leq v_O \leq 15 \text{ V}$.

If the wiper is set at its halfway point, then there is a 2.5-k Ω resistor above the wiper and a 2.5-k Ω wiper in parallel with the 5-k Ω resistor. The equivalent circuit is shown below.

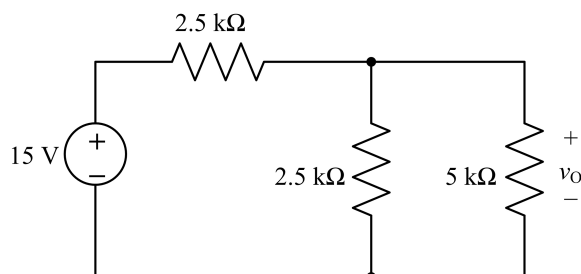

Combine the 2.5-k Ω and 5-k Ω resistors in parallel to get an equivalent resistance of $R_{\text{EQ}} = (2.5)(5)/(2.5 + 5) = 1.667 \text{ k}\Omega$. Apply voltage division to find the output voltage as follows:

$$v_O = \frac{R_{\text{EQ}}}{2.5 + R_{\text{EQ}}}(15) = \frac{1.667}{2.5 + 1.667}(15) = 6.0 \text{ V}$$

Exercise 2–25.

(a) Find i_y and i_z in the circuit of Figure 2–47(a).

Use current division to find all of the currents. Note that i_z flows through an equivalent resistance of $10\ \Omega$.

$$i_x = \left(\frac{\frac{1}{20}}{\frac{1}{20} + \frac{1}{20} + \frac{1}{10}} \right) 5 = 1.25\ \text{A}$$

$$i_y = \left(\frac{\frac{1}{20}}{\frac{1}{20} + \frac{1}{20} + \frac{1}{10}} \right) 5 = 1.25\ \text{A}$$

$$i_z = \left(\frac{\frac{1}{10}}{\frac{1}{20} + \frac{1}{20} + \frac{1}{10}} \right) 5 = 2.5\ \text{A}$$

(b) Show that the sum of i_x , i_y , and i_z equals the source current.

Sum the currents found in part (a), $i_x + i_y + i_z = 1.25 + 1.25 + 2.5 = 5\ \text{A}$.

Exercise 2–26. The circuit in Figure 2–48 shows a delicate device that is modeled by a $90\text{-}\Omega$ equivalent resistance. The device requires a current of $1\ \text{mA}$ to operate properly. A 1.5-mA fuse is inserted in series with the device to protect it from overheating. The resistance of the fuse is $10\ \Omega$. Without the shunt resistance R_x , the source would deliver $5\ \text{mA}$ to the device, causing the fuse to blow. Inserting a shunt resistor R_x diverts a portion of the available source current around the fuse and device. Select a value of R_x so only $1\ \text{mA}$ is delivered to the device.

The equivalent resistance of the device and its fuse is $100\ \Omega$. Write the current division equation such that the current through the device is $1\ \text{mA}$ and then solve for the shunt resistance R_x .

$$1 = \left(\frac{\frac{1}{100}}{\frac{1}{100} + \frac{1}{R_x} + \frac{1}{100}} \right) 10 = \left(\frac{R_x}{R_x + 100 + R_x} \right) 10 = \left(\frac{R_x}{2R_x + 100} \right) 10$$

$$2R_x + 100 = 10R_x$$

$$8R_x = 100$$

$$R_x = 12.5\ \Omega$$

Exercise 2–27. Repeat the problem of Example 2–23 if the battery's internal resistance increases to $70\ \text{m}\Omega$. Will there be sufficient current available to start the car?

Perform a source transformation with the 12.6-V battery and the $70\text{-m}\Omega$ resistor. The resulting current source has a value of $180\ \text{A}$, so it cannot supply $210.1\ \text{A}$ to the starter and accessories. Using the second approach described in Example 2–23, the current through the source resistance is $210.1\ \text{A}$ and the resistance is $70\ \text{m}\Omega$. The voltage drop across the source resistance is $(210.1)(0.070) = 14.707\ \text{V}$. This voltage is greater than the battery rating, so there will not be sufficient current to start the car.

Exercise 2–28.

(a) Find the currents i_s , i_1 , i_2 , and i_3 in the R - $2R$ circuit shown in Figure 2–51

In the figure, let node 1 be the node from which current i_1 exits. Label nodes 2 and 3 similarly with respect to currents i_2 and i_3 . Find the equivalent resistance in the circuit, working from right to left. The equivalent resistance to the right of node 3 is $100\ \Omega \parallel 100\ \Omega = 50\ \Omega$. The equivalent resistance to the right of node