

**PROBLEM 2-1**

**Statement:** Find three (or other number as assigned) of the following common devices. Sketch careful kinematic diagrams and find their total degrees of freedom.

- a. An automobile hood hinge mechanism
- b. An automobile hatchback lift mechanism
- c. An electric can opener
- d. A folding ironing board
- e. A folding card table
- f. A folding beach chair
- g. A baby swing
- h. A folding baby walker
- i. A fancy corkscrew as shown in Figure P2-9
- j. A windshield wiper mechanism
- k. A dump-truck dump mechanism
- l. A trash truck dumpster mechanism
- m. A pickup tailgate mechanism
- n. An automobile jack
- o. A collapsible auto radio antenna

**Solution:** See Mathcad file P0201.

Equation 2.1c is used to calculate the mobility (*DOF*) of each of the models below.

- a. An automobile hood hinge mechanism.

The hood (3) is linked to the body (1) through two rocker links (2 and 4).

Number of links  $L := 4$

Number of full joints  $J_1 := 4$

Number of half joints  $J_2 := 0$

$$M := 3 \cdot (L - 1) - 2 \cdot J_1 - J_2$$

$$M = 1$$

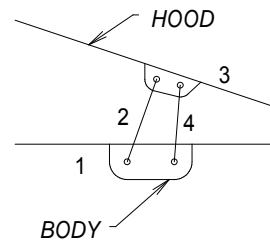

- b. An automobile hatchback lift mechanism.

The hatch (2) is pivoted on the body (1) and is linked to the body by the lift arm, which can be modeled as two links (3 and 4) connected through a translating slider joint.

Number of links  $L := 4$

Number of full joints  $J_1 := 4$

Number of half joints  $J_2 := 0$

$$M := 3 \cdot (L - 1) - 2 \cdot J_1 - J_2$$

$$M = 1$$

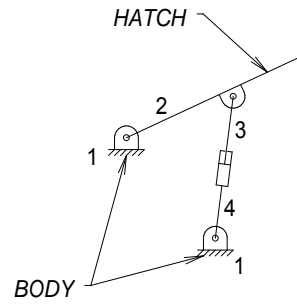

c. An electric can opener has 2 *DOF*.

d. A folding ironing board.

The board (1) itself has one pivot (full) joint and one pin-in-slot sliding (half) joint. The two legs (2 and 3) have a common pivot. One leg connects to the pivot joint on the board and the other to the slider joint.

Number of links  $L := 3$

Number of full joints  $J_1 := 2$

Number of half joints  $J_2 := 1$

$$M := 3 \cdot (L - 1) - 2 \cdot J_1 - J_2$$

$$M = 1$$

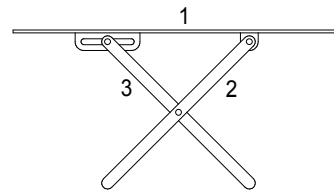

e. A folding card table has 7 *DOF*: One for each leg, 2 for location in *xy* space, and one for angular orientation.

f. A folding beach chair.

The seat (3) and the arms (6) are ternary links. The seat is linked to the front leg(2), the back (5) and a coupling link (4). The arms are linked to the front leg (2), the rear leg (1), and the back (5). Links 1, 2, 4, and 5 are binary links. The analysis below is appropriate when the chair is not fully opened. When fully opened, one or more links are prevented from moving by a stop. Subtract 1 *DOF* when forced against the stop.

Number of links  $L := 6$

Number of full joints  $J_1 := 7$

Number of half joints  $J_2 := 0$

$$M := 3 \cdot (L - 1) - 2 \cdot J_1 - J_2$$

$$M = 1$$

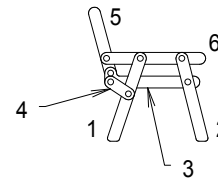

g. A baby swing has 4 *DOF*: One for the angular orientation of the swing with respect to the frame, and 3 for the location and orientation of the frame with respect to a 2-D frame.

- h. A folding baby walker has 4 *DOF*: One for the degree to which it is unfolded, and 3 for the location and orientation of the walker with respect to a 2-D frame.
- i. A fancy corkscrew has 2 *DOF*: The screw can be rotated and the arms rotate to translate the screw.
- j. A windshield wiper mechanism has 1 *DOF*: The position of the wiper blades is defined by a single input.
- k. A dump-truck dump mechanism has 1 *DOF*: The angle of the dump body is determined by the length of the hydraulic cylinder that links it to the body of the truck.
- l. A trash truck dumpster mechanism has 2 *DOF*: These are generally a rotation and a translation.
- m. A pickup tailgate mechanism has 1 *DOF*:
- n. An automobile jack has 4 *DOF*: One is the height of the jack and the other 3 are the position and orientation of the jack with respect to a 2-D frame.
- o. A collapsible auto radio antenna has as many *DOF* as there are sections, less one.

<b>PROBLEM 2-2</b>
--------------------

**Statement:** How many DOF do you have in your wrist and hand combined?

**Solution:** See Mathcad file P0202.

1. Holding the palm of the hand level and facing toward the floor, the hand can be rotated about an axis through the wrist that is parallel to the floor (and perpendicular to the forearm axis) and one perpendicular to the floor ( $2\ DOF$ ). The wrist can rotate about the forearm axis ( $1\ DOF$ ).
2. Each finger (and thumb) can rotate up and down and side-to-side about the first joint. Additionally, each finger can rotate about each of the two remaining joints for a total of  $4\ DOF$  for each finger (and thumb).
3. Adding all  $DOF$ , the total is

Wrist	1
Hand	2
Thumb	4
Fingers 4x4	<u>16</u>
TOTAL	23

**PROBLEM 2-3**

**Statement:** How many *DOF* do the following joints have?

- a. Your knee
- b. Your ankle
- c. Your shoulder
- d. Your hip
- e. Your knuckle

**Solution:** See Mathcad file P0203.

- a. Your knee.  
1 *DOF*: A rotation about an axis parallel to the ground.
- b. Your ankle.  
3 *DOF*: Three rotations about mutually perpendicular axes.
- c. Your shoulder.  
3 *DOF*: Three rotations about mutually perpendicular axes.
- d. Your hip.  
3 *DOF*: Three rotations about mutually perpendicular axes.
- e. Your knuckle.  
2 *DOF*: Two rotations about mutually perpendicular axes.

**PROBLEM 2-4**

**Statement:** How many DOF do the following have in their normal environment?

- a. A submerged submarine
- b. An earth-orbit satellite
- c. A surface ship
- d. A motorcycle (road bike)
- e. A two-button mouse
- f. A computer joy stick.

**Solution:** See Mathcad file P0204.

- a. A submerged submarine.

Using a coordinate frame attached to earth, or an inertial coordinate frame, a submarine has 6 *DOF*: 3 linear coordinates and 3 angles.

- b. An earth-orbit satellite.

If the satellite was just a particle it would have 3 *DOF*. But, since it probably needs to be oriented with respect to the earth, sun, etc., it has 6 *DOF*.

- c. A surface ship.

There is no difference between a submerged submarine and a surface ship, both have 6 *DOF*. One might argue that, for an earth-centered frame, the depth of the ship with respect to mean sea level is constant, however that is not strictly true. A ship's position is generally given by two coordinates (longitude and latitude). For a given position, a ship can also have pitch, yaw, and roll angles. Thus, for all practical purposes, a surface ship has 5 *DOF*.

- d. A motorcycle.

At an intersection, the motorcycle's position is given by two coordinates. In addition, it will have some heading angle (turning a corner) and roll angle (if turning). Thus, there are 4 *DOF*.

- e. A two-button mouse.

A two-button mouse has 4 *DOF*. It can move in the x and y directions and each button has 1 *DOF*.

- f. A computer joy stick.

The joy stick has 2 *DOF* (x and y) and orientation, for a total of 3 *DOF*.

**PROBLEM 2-5**

**Statement:** Are the joints in Problem 2-3 force closed or form closed?

**Solution:** See Mathcad file P0205.

They are force closed by ligaments that hold them together. None are geometrically closed.

**PROBLEM 2-6**

**Statement:** Describe the motion of the following items as pure rotation, pure translation, or complex planar motion.

- a. A windmill
- b. A bicycle (in the vertical plane, not turning)
- c. A conventional "double-hung" window
- d. The keys on a computer keyboard
- e. The hand of a clock
- f. A hockey puck on the ice
- g. A "casement" window

**Solution:** See Mathcad file P0206.

- a. A windmill.  
Pure rotation.
- b. A bicycle (in the vertical plane, not turning).  
Pure translation for the frame, complex planar motion for the wheels.
- c. A conventional "double-hung" window.  
Pure translation.
- d. The keys on a computer keyboard.  
Pure translation.
- e. The hand of a clock.  
Pure rotation.
- f. A hockey puck on the ice.  
Complex planar motion.
- g. A "casement" window.  
Pure rotation.

**PROBLEM 2-7**

**Statement:** Calculate the mobility of the linkages assigned from Figure P2-1 part 1 and part 2.

**Solution:** See Figure P2-1 and Mathcad file P0207.

1. Use equation 2.1c (Kutzbach's modification) to calculate the mobility.

a. Number of links  $L := 6$

Number of full joints  $J_1 := 7$

Number of half joints  $J_2 := 1$

$$M := 3 \cdot (L - 1) - 2 \cdot J_1 - J_2$$

$$M = 0$$

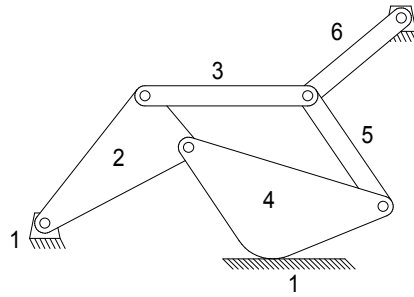

(a)

b. Number of links  $L := 3$

Number of full joints  $J_1 := 2$

Number of half joints  $J_2 := 1$

$$M := 3 \cdot (L - 1) - 2 \cdot J_1 - J_2$$

$$M = 1$$

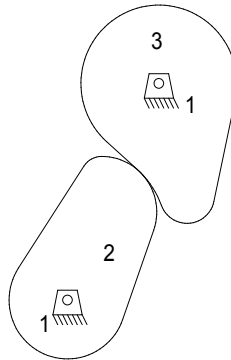

(b)

c. Number of links  $L := 4$

Number of full joints  $J_1 := 4$

Number of half joints  $J_2 := 0$

$$M := 3 \cdot (L - 1) - 2 \cdot J_1 - J_2$$

$$M = 1$$

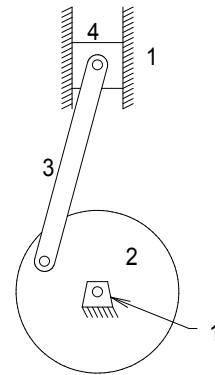

(c)

- d. Number of links  $L := 7$   
 Number of full joints  $J_1 := 7$   
 Number of half joints  $J_2 := 1$   
 $M := 3 \cdot (L - 1) - 2 \cdot J_1 - J_2$   
 $M = 3$

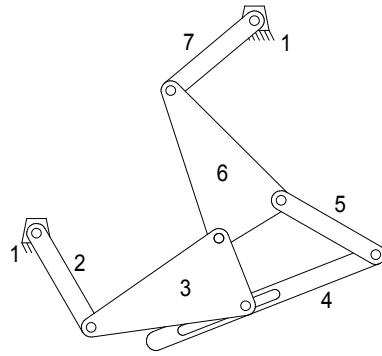

(d)

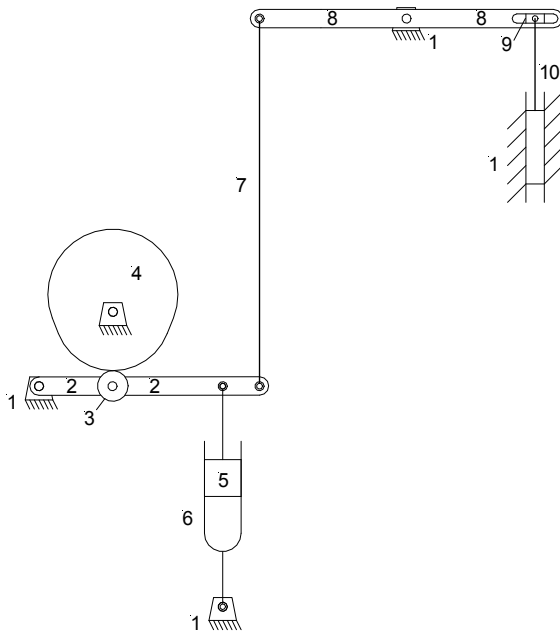

(e)

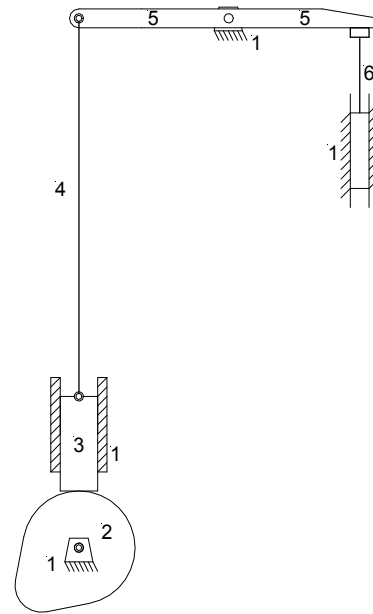

(f)

- e. Number of links  $L := 10$   
 Number of full joints  $J_1 := 13$   
 Number of half joints  $J_2 := 0$   
 $M := 3 \cdot (L - 1) - 2 \cdot J_1 - J_2$   
 $M = 1$

- f. Number of links  $L := 6$   
 Number of full joints  $J_1 := 6$   
 Number of half joints  $J_2 := 2$   
 $M := 3 \cdot (L - 1) - 2 \cdot J_1 - J_2$   
 $M = 1$

g. Number of links  $L := 8$

Number of full joints  $J_1 := 9$

Number of half joints  $J_2 := 2$

$$M := 3 \cdot (L - 1) - 2 \cdot J_1 - J_2$$

$$M = 1$$

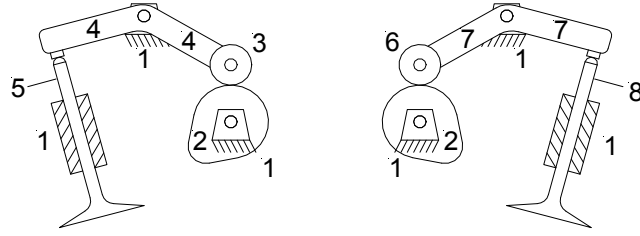

(g)

h. Number of links  $L := 4$

Number of full joints  $J_1 := 4$

Number of half joints  $J_2 := 0$

$$M := 3 \cdot (L - 1) - 2 \cdot J_1 - J_2$$

$$M = 1$$

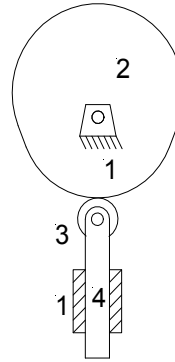

(h)

**PROBLEM 2-8**

**Statement:** Identify the items in Figure P2-1 as mechanisms, structures, or preloaded structures.

**Solution:** See Figure P2-1 and Mathcad file P0208.

- Use equation 2.1c (Kutzbach's modification) to calculate the mobility and the definitions in Section 2.5 of the text to classify the linkages.

a. Number of links  $L := 6$

Number of full joints  $J_1 := 7$

Number of half joints  $J_2 := 1$

$$M := 3 \cdot (L - 1) - 2 \cdot J_1 - J_2$$

$M = 0$  Structure

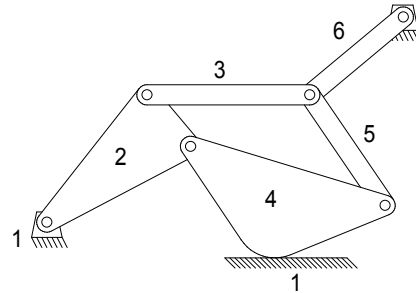

(a)

b. Number of links  $L := 3$

Number of full joints  $J_1 := 2$

Number of half joints  $J_2 := 1$

$$M := 3 \cdot (L - 1) - 2 \cdot J_1 - J_2$$

$M = 1$  Mechanism

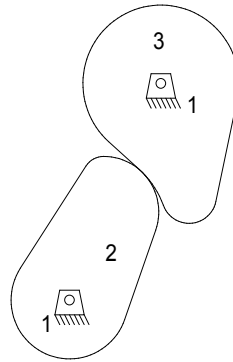

(b)

c. Number of links  $L := 4$

Number of full joints  $J_1 := 4$

Number of half joints  $J_2 := 0$

$$M := 3 \cdot (L - 1) - 2 \cdot J_1 - J_2$$

$M = 1$  Mechanism

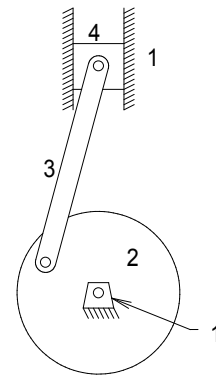

(c)

d. Number of links  $L := 7$

Number of full joints  $J_1 := 7$

Number of half joints  $J_2 := 1$

$$M := 3 \cdot (L - 1) - 2 \cdot J_1 - J_2$$

$$M = 3 \quad \text{Mechanism}$$

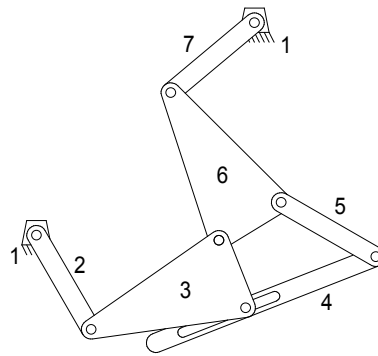

(d)

**PROBLEM 2-9**

**Statement:** Use linkage transformation on the linkage of Figure P2-1a to make it a 1-DOF mechanism.

**Solution:** See Figure P2-1a and Mathcad file P0209.

1. The mechanism in Figure P2-1a has mobility:

$$\text{Number of links} \quad L := 6$$

$$\text{Number of full joints} \quad J_1 := 7$$

$$\text{Number of half joints} \quad J_2 := 1$$

$$M := 3 \cdot (L - 1) - 2 \cdot J_1 - J_2$$

$$M = 0$$

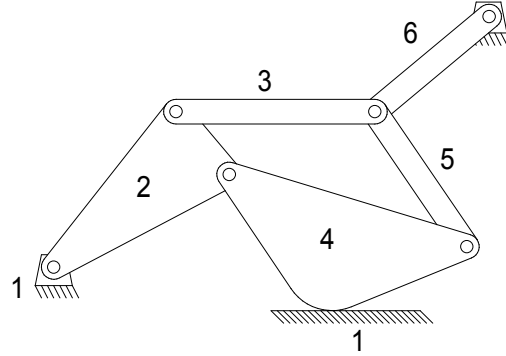

2. Use rule 2, which states: "Any full joint can be replaced by a half joint, but this will increase the *DOF* by one." One way to do this is to replace one of the pin joints with a pin-in-slot joint such as that shown in Figure 2-3c. Choosing the joint between links 2 and 4, we now have mobility:

$$\text{Number of links} \quad L := 6$$

$$\text{Number of full joints} \quad J_1 := 6$$

$$\text{Number of half joints} \quad J_2 := 2$$

$$M := 3 \cdot (L - 1) - 2 \cdot J_1 - J_2$$

$$M = 1$$

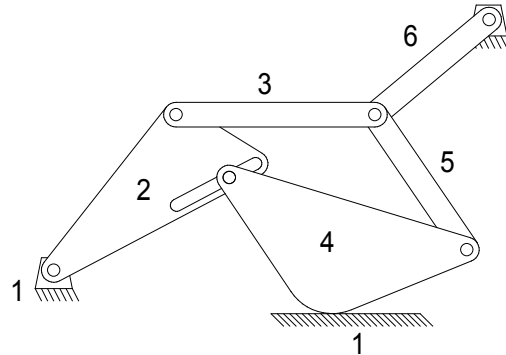

<b>PROBLEM 2-10</b>
---------------------

**Statement:** Use linkage transformation on the linkage of Figure P2-1d to make it a 2-DOF mechanism.

**Solution:** See Figure P2-1d and Mathcad file P0210.

1. The mechanism in Figure P2-1d has mobility:

Number of links  $L := 7$

Number of full joints  $J_1 := 7$

Number of half joints  $J_2 := 1$

$$M := 3 \cdot (L - 1) - 2 \cdot J_1 - J_2$$

$$M = 3$$

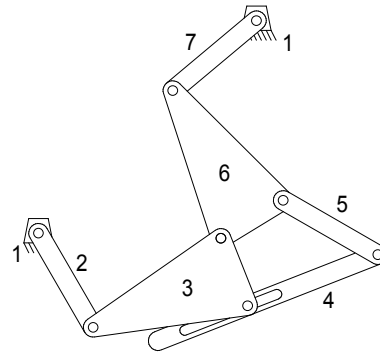

2. Use rule 3, which states: "Removal of a link will reduce the *DOF* by one." One way to do this is to remove link 7 such that link 6 pivots on the fixed pin attached to the ground link (1). We now have mobility:

Number of links  $L := 6$

Number of full joints  $J_1 := 6$

Number of half joints  $J_2 := 1$

$$M := 3 \cdot (L - 1) - 2 \cdot J_1 - J_2$$

$$M = 2$$

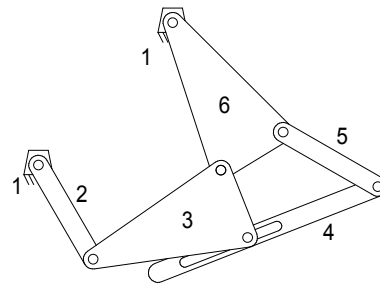

<b>PROBLEM 2-11</b>
---------------------

**Statement:** Use number synthesis to find all the possible link combinations for 2-DOF, up to 9 links, to hexagonal order, using only revolute joints.

**Solution:** See Mathcad file P0211.

1. Use equations 2.4a and 2.6 with  $DOF = 2$  and iterate the solution for valid combinations. Note that the number of links must be odd to have an even  $DOF$  (see Eq. 2.4). The smallest possible 2-DOF mechanism is then 5 links since three will give a structure (the delta triplet, see Figure 2-7).

$$L := B + T + Q + P + H \quad L - 3 - M := T + 2 \cdot Q + 3 \cdot P + 4 \cdot H \quad M := 2$$

$$L - 5 := T + 2 \cdot Q + 3 \cdot P + 4 \cdot H$$

2. For  $L := 5$

$$0 := T + 2 \cdot Q + 3 \cdot P + 4 \cdot H \quad 0 = T = Q = P = H \quad B := 5$$

3. For  $L := 7$

$$2 := T + 2 \cdot Q + 3 \cdot P + 4 \cdot H \quad H := 0 \quad P := 0$$

$$\begin{array}{lll} \text{Case 1:} & Q := 0 & T := 2 - 2 \cdot Q - 3 \cdot P - 4 \cdot H & T = 2 \\ & & B := L - T - Q - P - H & B = 5 \end{array}$$

$$\begin{array}{lll} \text{Case 2:} & Q := 1 & T := 2 - 2 \cdot Q - 3 \cdot P - 4 \cdot H & T = 0 \\ & & B := L - T - Q - P - H & B = 6 \end{array}$$

4. For  $L := 9$

$$4 := T + 2 \cdot Q + 3 \cdot P + 4 \cdot H$$

$$\begin{array}{llll} \text{Case 1:} & H := 1 & T := 0 & Q := 0 & P := 0 \\ & & B := L - T - Q - P - H & & B = 8 \end{array}$$

$$\begin{array}{ll} \text{Case 2a:} & H := 0 \\ & 4 := T + 2 \cdot Q + 3 \cdot P \\ & 9 := B + T + Q + P \end{array}$$

$$\begin{array}{llll} \text{Case 2b:} & P := 1 & 1 := T + 2 \cdot Q & Q := 0 & T := 1 \\ & & B := L - T - Q - P - H & & B = 7 \end{array}$$

$$\begin{array}{ll} \text{Case 2c:} & P := 0 \\ & 4 := T + 2 \cdot Q \\ & 9 := B + T + Q \end{array}$$

$$\begin{array}{lll} \text{Case 2c1:} & Q := 2 & T := 4 - 2 \cdot Q & T = 0 \\ & & B := 9 - T - Q & B = 7 \end{array}$$

$$\begin{array}{lll} \text{Case 2c2:} & Q := 1 & T := 4 - 2 \cdot Q & T = 2 \\ & & B := 9 - T - Q & B = 6 \end{array}$$

$$\begin{array}{lll} \text{Case 2c3:} & Q := 0 & T := 4 - 2 \cdot Q & T = 4 \\ & & B := 9 - T - Q & B = 5 \end{array}$$

**PROBLEM 2-12**

**Statement:** Find all of the valid isomers of the eightbar 1-*DOF* link combinations in Table 2-2 (p. 38) having:

- Four binary and four ternary links.
- Five binaries, two ternaries, and one quaternary link.
- Six binaries and two quaternary links.
- Six binaries, one ternary, and one pentagonal link.

**Solution:** See Mathcad file P0212.

- Table 2-3 lists 16 possible isomers for an eightbar chain. However, Table 2-2 shows that there are five possible link sets, four of which are listed above. Therefore, we expect that the 16 valid isomers are distributed among the five link sets and that there will be fewer than 16 isomers among the four link sets listed above.
- One method that is helpful in finding isomers is to represent the linkage in terms of molecules as defined in Franke's Condensed Notations for Structural Synthesis. A summary of the rules for obtaining Franke's molecules follows:
  - The links of order greater than 2 are represented by circles.
  - A number is placed within each circle (the "valence" number) to describe the type (ternary, quaternary, etc.) of link.
  - The circles are connected using straight lines. The number of straight lines emanating from a circle must be equal to its valence number.
  - Numbers (0, 1, 2, etc.) are placed on the straight lines to correspond to the number of binary links used in connecting the higher order links.
  - There is one-to-one correspondence between the molecule and the kinematic chain that it represents.

**a. Four binary and four ternary links.**

Draw 4 circles with valence numbers of 3 in each. Then find all unique combinations of straight lines that can be drawn that connect the circles such that there are exactly three lines emanating from each circle and the total of the numbers written on the lines is exactly equal to 4. In this case, there are three valid isomers as depicted by Franke's molecules and kinematic chains below.

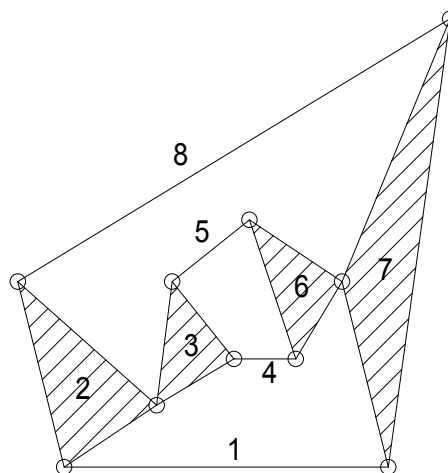
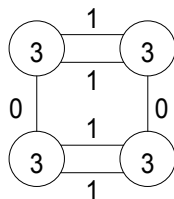

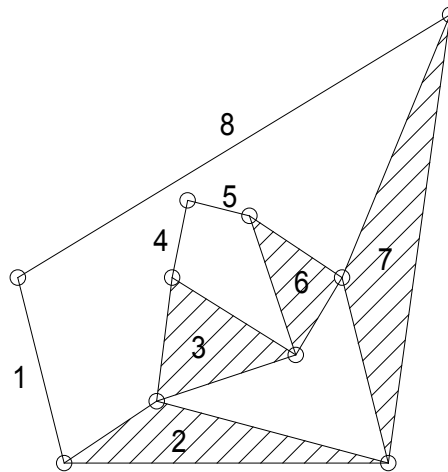
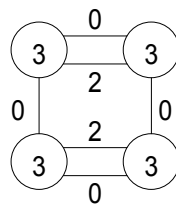
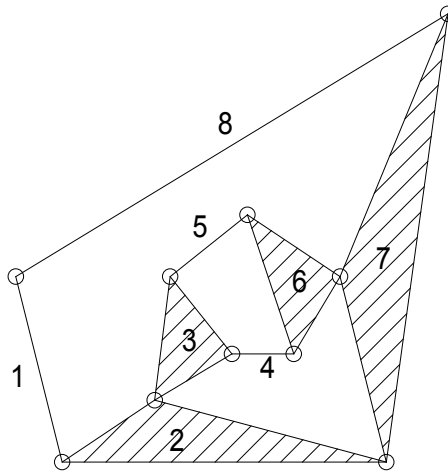
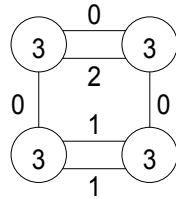

The mechanism shown in Figure P2-5b is the same eightbar isomer as that depicted schematically above.

**b. Five binaries, two ternaries, and one quaternary link.**

Draw 2 circles with valence numbers of 3 in each and one with a valence number of 4. Then find all unique combinations of straight lines that can be drawn that connect the circles such that there are exactly three lines emanating from each circle with valence of three and four lines from the circle with valence of four; and the total of the numbers written on the lines is exactly equal to 5. In this case, there are five valid isomers as depicted by Franke's molecules and kinematic chains below.

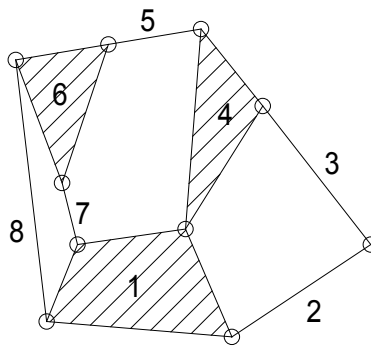
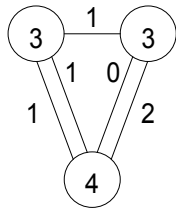
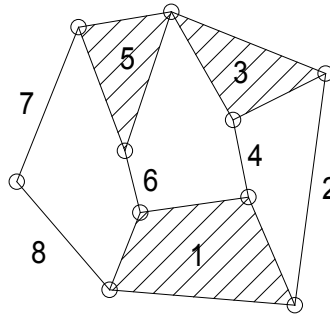
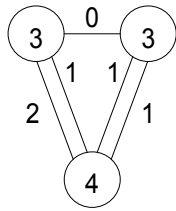
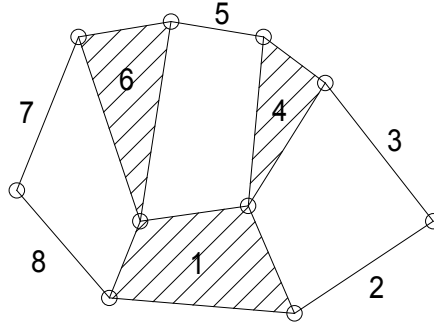
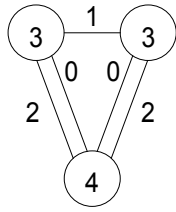
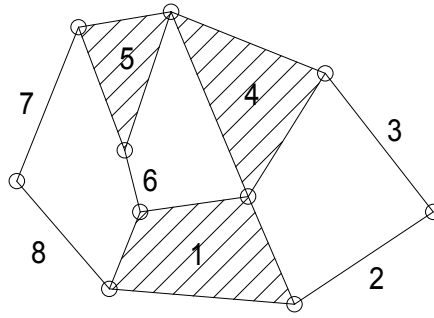
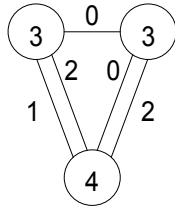

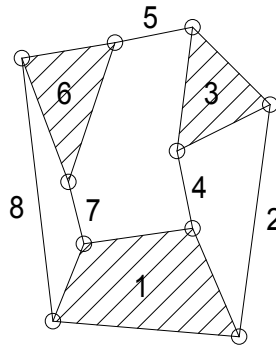
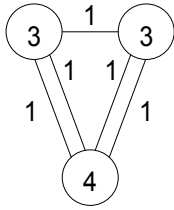

**c. Six binaries and two quaternary links.**

Draw 2 circles with valence numbers of 4 in each. Then find all unique combinations of straight lines that can be drawn that connect the circles such that there are exactly four lines emanating from each circle and the total of the numbers written on the lines is exactly equal to 6. In this case, there are two valid isomers as depicted by Franke's molecules and kinematic chains below.

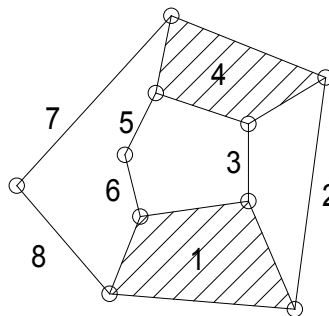
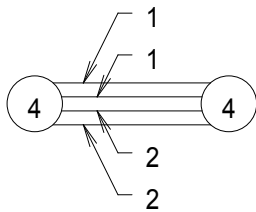
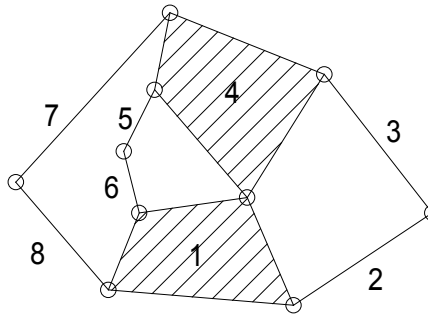
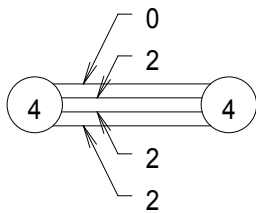

**d. Six binaries, one ternary, and one pentagonal link.**

There are no valid implementations of 6 binary links with 1 pentagonal link.

**PROBLEM 2-13**

**Statement:** Use linkage transformation to create a 1-*DOF* mechanism with two sliding full joints from a Stephenson's sixbar linkage as shown in Figure 2-14a (p. 47).

**Solution:** See Figure 2-14a and Mathcad file P0213.

1. The mechanism in Figure 2-14a has mobility:

Number of links  $L := 6$

Number of full joints  $J_1 := 7$

Number of half joints  $J_2 := 0$

$$M := 3 \cdot (L - 1) - 2 \cdot J_1 - J_2$$

$$M = 1$$

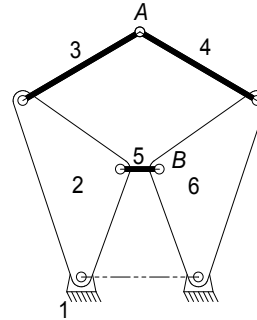

2. Use rule 1, which states: "Revolute joints in any loop can be replaced by prismatic joints with no change in *DOF* of the mechanism, provided that at least two revolute joints remain in the loop." One way to do this is to replace pin joints at *A* and *B* with translating full slider joints such as that shown in Figure 2-3b.

Note that the sliders are attached to links 3 and 5 in such a way that they cannot rotate relative to the links. The number of links and 1-*DOF* joints remains the same. There are no 2-*DOF* joints in either mechanism.

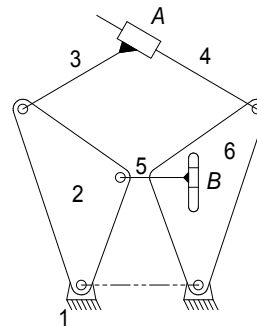

**PROBLEM 2-14**

**Statement:** Use linkage transformation to create a 1-DOF mechanism with one sliding full joint a half joint from a Stephenson's sixbar linkage as shown in Figure 2-14b (p. 48).

**Solution:** See Figure 2-14a and Mathcad file P0213.

1. The mechanism in Figure 2-14b has mobility:

Number of links  $L := 6$

Number of full joints  $J_1 := 7$

Number of half joints  $J_2 := 0$

$$M := 3 \cdot (L - 1) - 2 \cdot J_1 - J_2$$

$$M = 1$$

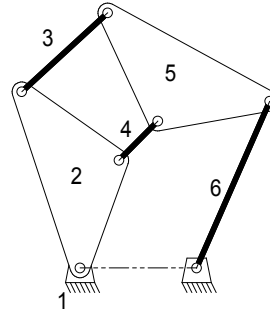

2. To get the sliding full joint, use rule 1, which states: "Revolute joints in any loop can be replaced by prismatic joints with no change in *DOF* of the mechanism, provided that at least two revolute joints remain in the loop." One way to do this is to replace pin joint links 3 and 5 with a translating full slider joint such as that shown in Figure 2-3b.

Note that the slider is attached to link 3 in such a way that it cannot rotate relative to the link. The number of links and 1-DOF joints remains the same.

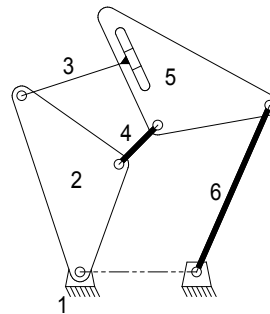

3. To get the half joint, use rule 4 on page 42, which states: "The combination of rules 2 and 3 above will keep the original *DOF* unchanged." One way to do this is to remove link 6 (and its two nodes) and insert a half joint between links 5 and 1.

Number of links  $L := 5$

Number of full joints  $J_1 := 5$

Number of half joints  $J_2 := 1$

$$M := 3 \cdot (L - 1) - 2 \cdot J_1 - J_2$$

$$M = 1$$

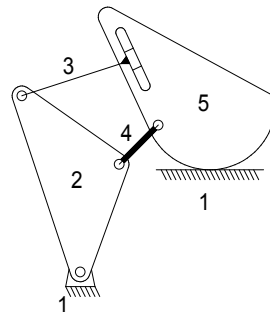

**PROBLEM 2-15**

**Statement:** Calculate the Grashof condition of the fourbar mechanisms defined below. Build cardboard models of the linkages and describe the motions of each inversion. Link lengths are in inches (or double given numbers for centimeters).

Part 1.

- |    |   |     |   |   |
|----|---|-----|---|---|
| a. | 2 | 4.5 | 7 | 9 |
| b. | 2 | 3.5 | 7 | 9 |
| c. | 2 | 4.0 | 6 | 8 |

Part 2.

- |    |   |     |   |   |
|----|---|-----|---|---|
| d. | 2 | 4.5 | 7 | 9 |
| e. | 2 | 4.0 | 7 | 9 |
| f. | 2 | 3.5 | 7 | 9 |

**Solution:** See Mathcad file P0215

1. Use inequality 2.8 to determine the Grashof condition.

$$\begin{array}{l}
 \text{Condition}(a,b,c,d) := \left\{ \begin{array}{l}
 S \leftarrow \min(a,b,c,d) \\
 L \leftarrow \max(a,b,c,d) \\
 SL \leftarrow S + L \\
 PQ \leftarrow a + b + c + d - SL \\
 \text{return "Grashof" if } SL < PQ \\
 \text{return "Special Grashof" if } SL = PQ \\
 \text{return "non-Grashof" otherwise}
 \end{array} \right.
 \end{array}$$

- a.  $\text{Condition}(2,4.5,7,9) = \text{"Grashof"}$
- b.  $\text{Condition}(2,3.5,7,9) = \text{"non-Grashof"}$
- c.  $\text{Condition}(2,4.0,6,8) = \text{"Special Grashof"}$

This is a special case Grashof since the sum of the shortest and longest is equal to the sum of the other two link lengths.

- d.  $\text{Condition}(2,4.5,7,9) = \text{"Grashof"}$
- e.  $\text{Condition}(2,4.9,7,9) = \text{"Grashof"}$
- f.  $\text{Condition}(2,3.5,7,9) = \text{"non-Grashof"}$

**PROBLEM 2-16**

**Statement:** Which type(s) of electric motor would you specify

- a. To drive a load with large inertia.
- b. To minimize variation of speed with load variation.
- c. To maintain accurate constant speed regardless of load variations.

**Solution:** See Mathcad file P0216.

- a. Motors with high starting torque are suited to drive large inertia loads. Those with this characteristic include series-wound, compound-wound, and shunt-wound DC motors, and capacitor-start AC motors.
- b. Motors with flat torque-speed curves (in the operating range) will minimize variation of speed with load variation. Those with this characteristic include shunt-wound DC motors, and synchronous and capacitor-start AC motors.
- b. Speed-controlled DC motors will maintain accurate constant speed regardless of load variations.

**PROBLEM 2-17**

**Statement:** Describe the difference between a cam-follower (half) joint and a pin joint.

**Solution:** See Mathcad file P0217.

1. A pin joint has one rotational *DOF*. A cam-follower joint has 2 *DOF*, rotation and translation. The pin joint also captures its lubricant in the annulus between pin and bushing while the cam-follower joint squeezes its lubricant out of the joint.

**PROBLEM 2-18**

**Statement:** Examine an automobile hood hinge mechanism of the type described in Section 2.14. Sketch it carefully. Calculate its *DOF* and Grashof condition. Make a cardboard model. Analyze it with a free-body diagram. Describe how it keeps the hood up.

**Solution:** Solution of this problem will depend upon the specific mechanism modeled by the student.

**PROBLEM 2-19**

**Statement:** Find an adjustable arm desk lamp of the type shown in Figure P2-2. Sketch it carefully. Measure it and sketch it to scale. Calculate its *DOF* and Grashof condition. Make a cardboard model. Analyze it with a free-body diagram. Describe how it keeps itself stable. Are there any positions in which it loses stability? Why?

**Solution:** Solution of this problem will depend upon the specific mechanism modeled by the student.

**PROBLEM 2-20**

- Statement:** The torque-speed curve for a 1/8 hp permanent magnet (PM) DC motor is shown in Figure P2-3. The rated speed for this fractional horsepower motor is 2500 rpm at a rated voltage of 130V. Determine:
- The rated torque in oz-in (ounce-inches, the industry standard for fractional hp motors)
  - The no-load speed
  - Plot the power-torque curve and determine the maximum power that the motor can deliver.

**Given:** Rated speed,  $N_R$        $N_R := 2500 \cdot \text{rpm}$       Rated power,  $H_R$        $H_R := \frac{1}{8} \cdot \text{hp}$

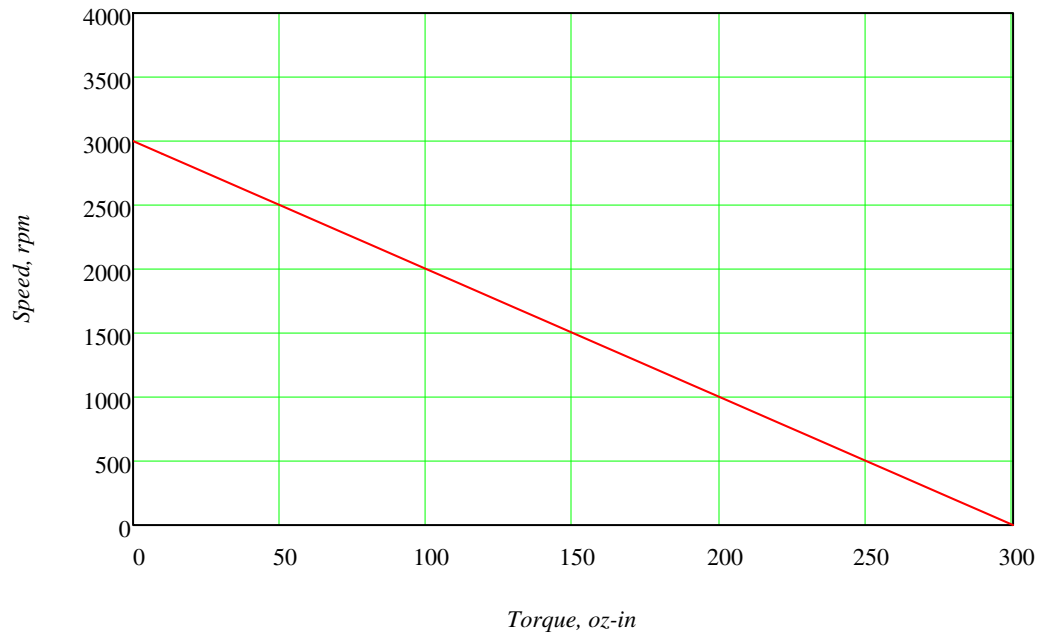

Figure P2-3 Torque-speed Characteristic of a 1/8 HP, 2500 rpm PM DC Motor

**Solution:** See Figure P2-3 and Mathcad file P0220.

- a. The rated torque is found by dividing the rated power by the rated speed:

$$\text{Rated torque, } T_R \quad T_R := \frac{H_R}{N_R} \quad T_R = 50 \cdot \text{ozf} \cdot \text{in}$$

- b. The no-load speed occurs at  $T=0$ . From the graph this is 3000 rpm.

- c. The power is the product of the speed and the torque. From the graph the equation for the torque-speed curve is:

$$N(T) := -\frac{3000 \cdot \text{rpm}}{300 \cdot \text{ozf} \cdot \text{in}} \cdot T + 3000 \cdot \text{rpm}$$

and the power, therefore, is:

$$H(T) := -10 \cdot \frac{\text{rpm}}{\text{ozf}\cdot\text{in}} \cdot T^2 + 3000 \cdot \text{rpm} \cdot T$$

Plotting the power as a function of torque over the range  $T := 0 \cdot \text{ozf}\cdot\text{in}, 10 \cdot \text{ozf}\cdot\text{in} \dots 300 \cdot \text{ozf}\cdot\text{in}$

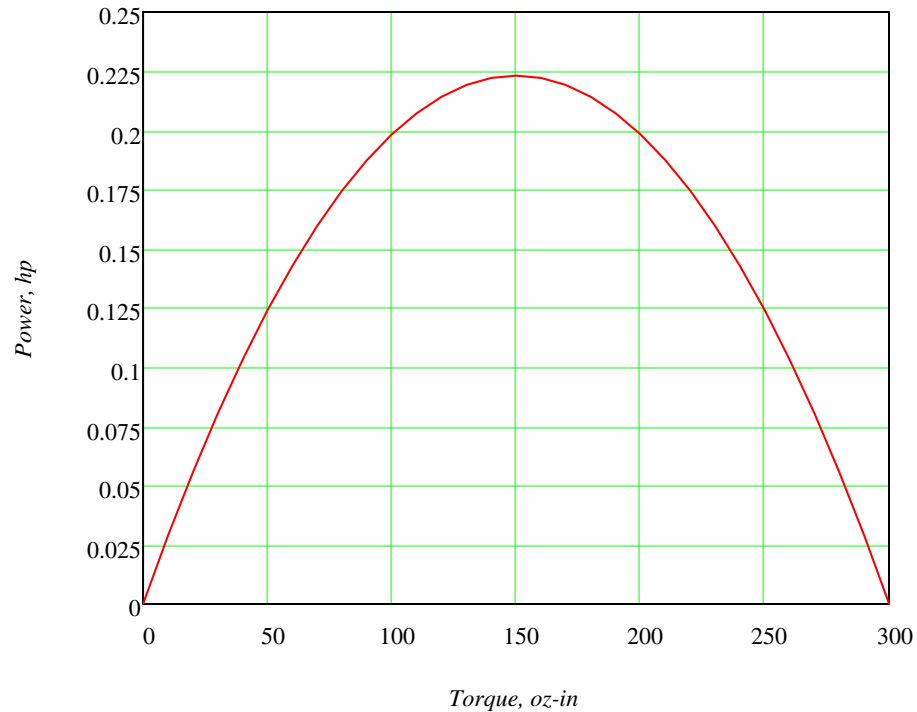

Maximum power occurs when  $dH/dT = 0$ . The value of  $T$  at maximum power is:

$$\text{Value of } T \text{ at } H_{max} \quad T_{Hmax} := 3000 \cdot \text{rpm} \cdot \frac{\text{ozf}\cdot\text{in}}{2 \cdot 10 \cdot \text{rpm}} \quad T_{Hmax} = 150 \cdot \text{ozf}\cdot\text{in}$$

$$\text{Maximum power} \quad H_{max} := H(T_{Hmax}) \quad H_{max} = 0.223 \cdot \text{hp}$$

$$\text{Speed at max power} \quad N_{Hmax} := N(T_{Hmax}) \quad N_{Hmax} = 1500 \cdot \text{rpm}$$

Note that the curve goes through the rated power point of 0.125 hp at the rated torque of 50 oz-in.

**PROBLEM 2-21**

**Statement:** Find the mobility of the mechanisms in Figure P2-4.

**Solution:** See Figure P2-4 and Mathcad file P0221.

1. Use equation 2.1c (Kutzbach's modification) to calculate the mobility.

a. This is a basic fourbar linkage. The input is link 2 and the output is link 4. The cross-hatched pivot pins at  $O_2$  and  $O_4$  are attached to the ground link (1).

Number of links  $L := 4$

Number of full joints  $J_1 := 4$

Number of half joints  $J_2 := 0$

$$M := 3 \cdot (L - 1) - 2 \cdot J_1 - J_2$$

$$M = 1$$

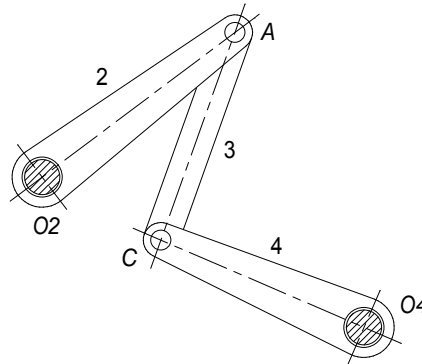

b. This is a fourbar linkage. The input is link 2, which in this case is the wheel 2 with a pin at A, and the output is link 4. The cross-hatched pivot pins at  $O_2$  and  $O_4$  are attached to the ground link (1).

Number of links  $L := 4$

Number of full joints  $J_1 := 4$

Number of half joints  $J_2 := 0$

$$M := 3 \cdot (L - 1) - 2 \cdot J_1 - J_2$$

$$M = 1$$

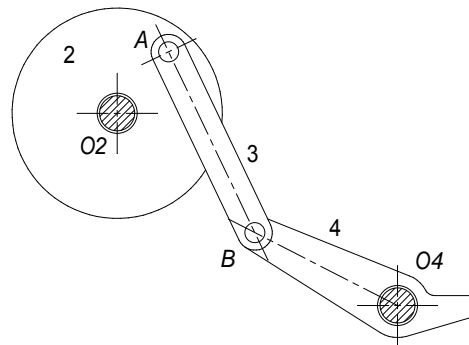

c. This is a 3-cylinder, rotary, internal combustion engine. The pistons (sliders) 6, 7, and 8 drive the output crank (2) through piston rods (couplers 3, 4, and 5). There are 3 full joints at the crank where rods 3, 4 and 5 are pinned to crank 2. The cross-hatched crank-shaft at  $O_2$  is supported by the ground link (1) through bearings.