

T H R E E

Modeling in the Time Domain

SOLUTIONS TO CASE STUDIES CHALLENGES

Antenna Control: State-Space Representation

For the power amplifier, $\frac{E_a(s)}{V_p(s)} = \frac{150}{s+150}$. Taking the inverse Laplace transform, $\dot{e}_a + 150e_a =$

$150v_p$. Thus, the state equation is

$$\dot{e}_a = -150e_a + 150v_p$$

For the motor and load, define the state variables as $x_1 = \theta_m$ and $x_2 = \dot{\theta}_m$. Therefore,

$$\dot{x}_1 = x_2 \tag{1}$$

Using the transfer function of the motor, cross multiplying, taking the inverse Laplace transform,

and using the definitions for the state variables,

$$\dot{x}_2 = -\frac{1}{J_m} \left(D_m + \frac{K_t K_a}{R_a} \right) x_2 + \frac{K_t}{R_a J_m} e_a \tag{2}$$

Using the gear ratio, the output equation is

$$y = 0.2x_1 \tag{3}$$

Also, $J_m = J_a + 5\left(\frac{1}{5}\right)^2 = 0.05 + 0.2 = 0.25$, $D_m = D_a + 3\left(\frac{1}{5}\right)^2 = 0.01 + 0.12 = 0.13$, $\frac{K_t}{R_a J_m} = \frac{1}{(5)(0.25)}$

$= 0.8$, and $\frac{1}{J_m} \left(D_m + \frac{K_t K_a}{R_a} \right) = 1.32$. Using Eqs. (1), (2), and (3) along with the previous values, the

state and output equations are,

$$\dot{\mathbf{x}} = \begin{bmatrix} 0 & 1 \\ 0 & -1.32 \end{bmatrix} \mathbf{x} + \begin{bmatrix} 0 \\ 0.8 \end{bmatrix} e_a; \mathbf{y} = \begin{bmatrix} 0.2 & 0 \end{bmatrix} \mathbf{x}$$

Aquifer: State-Space Representation

$$C_1 \frac{dh_1}{dt} = q_{i1} - q_{o1} + q_2 - q_1 + q_{21} = q_{i1} - 0 + G_2(h_2 - h_1) - G_1 h_1 + G_{21}(H_1 - h_1) =$$

$$-(G_2 + G_1 + G_{21})h_1 + G_2 h_2 + q_{i1} + G_{21}H_1$$

$$C_2 \frac{dh_2}{dt} = q_{i2} - q_{o2} + q_3 - q_2 + q_{32} = q_{i2} - q_{o2} + G_3(h_3 - h_2) - G_2(h_2 - h_1) + 0 = G_2 h_1 - [G_2 + G_3]h_2 + G_3 h_3 + q_{i2} - q_{o2}$$

$$C_3 \frac{dh_3}{dt} = q_{i3} - q_{o3} + q_4 - q_3 + q_{43} = q_{i3} - q_{o3} + 0 - G_3(h_3 - h_2) + 0 = G_3 h_2 - G_3 h_3 + q_{i3} - q_{o3}$$

Dividing each equation by C_i and defining the state vector as $\mathbf{x} = [h_1 \ h_2 \ h_3]^T$

$$\dot{\mathbf{x}} = \begin{bmatrix} \frac{-(G_1 + G_2 + G_3)}{C_1} & \frac{G_2}{C_1} & 0 \\ \frac{G_2}{C_2} & \frac{-(G_2 + G_3)}{C_2} & \frac{G_3}{C_2} \\ 0 & \frac{G_3}{C_3} & \frac{-G_3}{C_3} \end{bmatrix} \mathbf{x} + \begin{bmatrix} \frac{q_{i1} + G_{21}H_1}{C_1} \\ \frac{q_{i2} - q_{o2}}{C_2} \\ \frac{q_{i3} - q_{o3}}{C_3} \end{bmatrix} u(t)$$

$$\mathbf{y} = \begin{bmatrix} 1 & 0 & 0 \\ 0 & 1 & 0 \\ 0 & 0 & 1 \end{bmatrix} \mathbf{x}$$

where $u(t) =$ unit step function.

ANSWERS TO REVIEW QUESTIONS

1. (1) Can model systems other than linear, constant coefficients; (2) Used for digital simulation
2. Yields qualitative insight
3. That smallest set of variables that completely describe the system
4. The value of the state variables
5. The vector whose components are the state variables
6. The n-dimensional space whose bases are the state variables
7. State equations, an output equation, and an initial state vector (initial conditions)
8. Eight
9. Forms linear combinations of the state variables and the input to form the desired output
10. No variable in the set can be written as a linear sum of the other variables in the set.

11. (1) They must be linearly independent; (2) The number of state variables must agree with the order of the differential equation describing the system; (3) The degree of difficulty in obtaining the state equations for a given set of state variables.

12. The variables that are being differentiated in each of the linearly independent energy storage elements

13. Yes, depending upon the choice of circuit variables and technique used to write the system equations. For example, a three-loop problem with three energy storage elements could yield three simultaneous second-order differential equations which would then be described by six, first-order differential equations. This exact situation arose when we wrote the differential equations for mechanical systems and then proceeded to find the state equations.

14. The state variables are successive derivatives.

SOLUTIONS TO PROBLEMS

1.

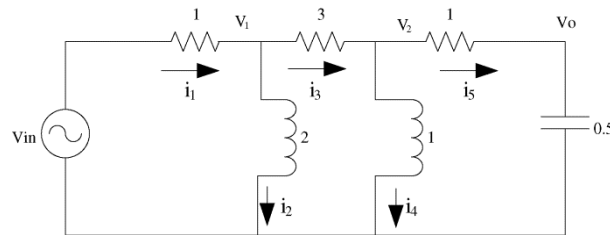

The state variables are i_2 , i_4 and v_o .

We have that $2 \frac{di_2}{dt} = v_1$, $\frac{di_4}{dt} = v_2$ and $0.5 \frac{dv_o}{dt} = i_5$.

Applying KVL around the external loop one gets

$$v_i - i_1 - 3i_3 - i_5 - v_o = 0$$

And in each one of the nodes

$$i_3 = i_1 - i_2 \text{ and } i_5 = i_3 - i_4$$

Substituting

$$v_i - i_1 - 3(i_1 - i_2) - (i_3 - i_4) - v_o = 0$$

or

$$v_i - i_1 - 3(i_1 - i_2) - ((i_1 - i_2) - i_4) - v_o = 0$$

Solving for i_1 one gets

$$i_1 = \frac{4}{5}i_2 + \frac{1}{5}i_4 + \frac{1}{5}v_i - \frac{1}{5}v_o$$

Thus

$$v_1 = v_i - i_1 = -\frac{4}{5}i_2 - \frac{1}{5}i_4 + \frac{4}{5}v_i + \frac{1}{5}v_o$$

$$\frac{di_2}{dt} = \frac{v_1}{2} = -\frac{2}{5}i_2 - \frac{1}{10}i_4 + \frac{2}{5}v_i + \frac{1}{10}v_o$$

Also

$$i_3 = i_1 - i_2 = -\frac{1}{5}i_2 + \frac{1}{5}i_4 + \frac{1}{5}v_i - \frac{1}{5}v_o$$

and

$$i_5 = i_3 - i_4 = -\frac{1}{5}i_2 - \frac{4}{5}i_4 + \frac{1}{5}v_i - \frac{1}{5}v_o$$

$$\frac{dv_o}{dt} = 2i_5 = -\frac{2}{5}i_2 - \frac{8}{5}i_4 + \frac{2}{5}v_i - \frac{2}{5}v_o$$

Finally

$$\frac{di_4}{dt} = v_2 = i_5 + v_o = -\frac{1}{5}i_2 - \frac{4}{5}i_4 + \frac{1}{5}v_i + \frac{4}{5}v_o$$

In matrix form we have

$$\begin{bmatrix} \frac{di_2}{dt} \\ \frac{di_4}{dt} \\ \frac{dv_o}{dt} \end{bmatrix} = \begin{bmatrix} -\frac{2}{5} & -\frac{1}{10} & \frac{1}{10} \\ -\frac{1}{5} & -\frac{4}{5} & \frac{4}{5} \\ -\frac{2}{5} & -\frac{8}{5} & -\frac{2}{5} \end{bmatrix} \begin{bmatrix} i_2 \\ i_4 \\ v_o \end{bmatrix} + \begin{bmatrix} \frac{2}{5} \\ \frac{1}{5} \\ \frac{2}{5} \end{bmatrix} v_o$$

$$y = v_o = \begin{bmatrix} 0 & 0 & 1 \end{bmatrix} \begin{bmatrix} i_2 \\ i_4 \\ v_o \end{bmatrix}$$

2.

Add branch currents and node voltages to the schematic and obtain,

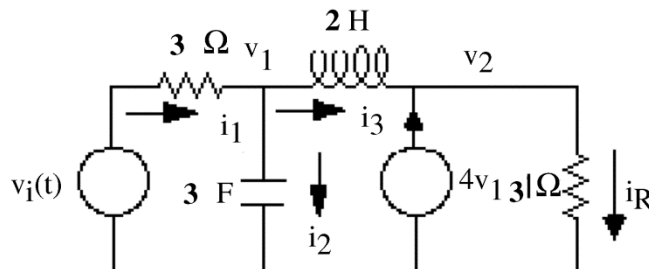

Write the differential equation for each energy storage element.

$$\frac{dv_1}{dt} = \frac{1}{3}i_2$$

$$\frac{di_3}{dt} = \frac{1}{2}v_L$$

Therefore the state vector is $\mathbf{x} = \begin{bmatrix} v_1 \\ i_3 \end{bmatrix}$

Now obtain v_L and i_2 , in terms of the state variables,

$$v_L = v_1 - v_2 = v_1 - 3i_R = v_1 - 3(i_3 + 4v_1) = -11v_1 - 3i_3$$

$$i_2 = i_1 - i_3 = \frac{1}{3}(v_i - v_1) - i_3 = -\frac{1}{3}v_1 - i_3 + \frac{1}{3}v_i$$

Also, the output is

$$y = i_R = 4v_1 + i_3$$

Hence,

$$\dot{\mathbf{x}} = \begin{bmatrix} -\frac{1}{9} & -\frac{1}{3} \\ -\frac{11}{2} & -\frac{3}{2} \end{bmatrix} \mathbf{x} + \begin{bmatrix} \frac{1}{9} \\ \mathbf{0} \end{bmatrix} v_i$$

$$y = [4 \quad 1] \mathbf{x}$$

3.

Let C_1 be the grounded capacitor and C_2 be the other. Now, writing the equations for the energy storage components yields,

$$\frac{di_L}{dt} = v_i - v_{C_1}$$

$$\frac{dv_{C_1}}{dt} = i_1 - i_2 \quad (1)$$

$$\frac{dv_{C_2}}{dt} = i_2 - i_3$$

Thus the state vector is $\mathbf{x} = \begin{bmatrix} i_L \\ v_{C_1} \\ v_{C_2} \end{bmatrix}$.

Now, find the three loop currents in terms of the state variables and the input.

Writing KVL around Loop 2 yields $v_{C_1} = v_{C_2} + 2i_2$.

Or, $i_2 = 0.5v_{C_1} - 0.5v_{C_2}$

Writing KVL around the outer loop yields $2i_3 + 2i_2 = v_i$

Or,

$$i_3 = 0.5v_i - i_2 = 0.5v_i - 0.5v_{C_1} + 0.5v_{C_2}$$

Also, $i_1 - i_3 = i_L$. Hence, $i_1 = i_L + i_3 = i_L + 0.5(v_i - v_{C_1} + v_{C_2})$

Substituting the loop currents in equations (1) yields the results in vector-matrix form,

$$\begin{bmatrix} \frac{di_L}{dt} \\ \frac{dv_{C_1}}{dt} \\ \frac{dv_{C_2}}{dt} \end{bmatrix} = \begin{bmatrix} 0 & -1 & 0 \\ 1 & -1 & 1 \\ 0 & 1 & -1 \end{bmatrix} \begin{bmatrix} i_L \\ v_{C_1} \\ v_{C_2} \end{bmatrix} + \begin{bmatrix} 1 \\ 0.5 \\ -0.5 \end{bmatrix} v_i$$

Since $v_o = i_2 = v_{C_1} - v_{C_2}$, the output equation is

$$y = \begin{bmatrix} 0 & 1 & -1 \end{bmatrix} \begin{bmatrix} i_L \\ v_{C_1} \\ v_{C_2} \end{bmatrix}$$

4.

Equations of motion in Laplace:

$$(2s^2 + 3s + 2)X_1(s) - (s + 2)X_2(s) - sX_3(s) = 0$$

$$-(s + 2)X_1(s) + (s^2 + 2s + 2)X_2(s) - sX_3(s) = F(s)$$

$$-sX_1(s) - sX_2(s) + (s^2 + 3s)X_3(s) = 0$$

Equations of motion in the time domain:

$$\begin{aligned}
2\frac{d^2x_1}{dt^2} + 3\frac{dx_1}{dt} + 2x_1 - \frac{dx_2}{dt} - 2x_2 - \frac{dx_3}{dt} &= 0 \\
-\frac{dx_1}{dt} - 2x_1 + \frac{d^2x_2}{dt^2} + 2\frac{dx_2}{dt} + 2x_2 - \frac{dx_3}{dt} &= f(t) \\
-\frac{dx_1}{dt} - \frac{dx_2}{dt} + \frac{d^2x_3}{dt^2} + 3\frac{dx_3}{dt} &= 0
\end{aligned}$$

Define state variables:

$$z_1 = x_1 \quad \text{or} \quad x_1 = z_1 \quad (1)$$

$$z_2 = \frac{dx_1}{dt} \quad \text{or} \quad \frac{dx_1}{dt} = z_2 \quad (2)$$

$$z_3 = x_2 \quad \text{or} \quad x_2 = z_3 \quad (3)$$

$$z_4 = \frac{dx_2}{dt} \quad \text{or} \quad \frac{dx_2}{dt} = z_4 \quad (4)$$

$$z_5 = x_3 \quad \text{or} \quad x_3 = z_5 \quad (5)$$

$$z_6 = \frac{dx_3}{dt} \quad \text{or} \quad \frac{dx_3}{dt} = z_6 \quad (6)$$

Substituting Eq. (1) in (2), (3) in (4), and (5) in (6), we obtain, respectively:

$$\frac{dz_1}{dt} = z_2 \quad (7)$$

$$\frac{dz_3}{dt} = z_4 \quad (8)$$

$$\frac{dz_5}{dt} = z_6 \quad (9)$$

Substituting Eqs. (1) through (6) into the equations of motion in the time domain and solving for the derivatives of the state variables and using Eqs. (7) through (9) yields the state equations:

$$\begin{aligned}\frac{dz_1}{dt} &= z_2 \\ \frac{dz_2}{dt} &= -z_1 - \frac{3}{2}z_2 + z_3 + \frac{1}{2}z_4 + \frac{1}{2}z_6 \\ \frac{dz_3}{dt} &= z_4 \\ \frac{dz_4}{dt} &= 2z_1 + z_2 - 2z_3 - 2z_4 + z_6 + f(t) \\ \frac{dz_5}{dt} &= z_6 \\ \frac{dz_6}{dt} &= z_2 + z_4 - 3z_6\end{aligned}$$

The output is $x_3 = z_5$.

In vector-matrix form:

$$\dot{\mathbf{Z}} = \begin{bmatrix} 0 & 1 & 0 & 0 & 0 & 0 \\ -1 & -1.5 & 1 & 0.5 & 0 & 0.5 \\ 0 & 0 & 0 & 1 & 0 & 0 \\ 2 & 1 & -2 & -2 & 0 & 1 \\ 0 & 0 & 0 & 0 & 0 & 1 \\ 0 & 1 & 0 & 1 & 0 & -3 \end{bmatrix} \mathbf{Z} + \begin{bmatrix} 0 \\ 0 \\ 0 \\ 1 \\ 0 \\ 0 \end{bmatrix} f(t)$$

$$\mathbf{y} = [0 \ 0 \ 0 \ 0 \ 1 \ 0] \mathbf{Z}$$

5.

The impedance equations are:

$$\begin{aligned}(s^2 + 2s + 1)X_1(s) - sX_2(s) - (s + 1)X_3(s) &= 0 \\ -sX_1(s) + (2s^2 + 2s + 1)X_2(s) - (s + 1)X_3(s) &= 0 \\ -(s + 1)X_1(s) - (s + 1)X_2(s) + (s^2 + 2s + 2)X_3(s) &= f(t)\end{aligned}$$

Taking the inverse Laplace transform

$$\begin{aligned}\ddot{x}_1 + 2\dot{x}_1 + x_1 - \dot{x}_2 - \dot{x}_3 - x_3 &= 0 \\ -\dot{x}_1 + 2\ddot{x}_2 + 2\dot{x}_2 + x_2 - \dot{x}_3 - x_3 &= 0 \\ -\dot{x}_1 - x_1 - \dot{x}_2 - x_2 + \ddot{x}_3 + 2\dot{x}_3 + 2x_3 &= f(t)\end{aligned}$$

$$\ddot{x}_1 = -2\dot{x}_1 - x_1 + \dot{x}_2 + \dot{x}_3 + x_3$$

$$\ddot{x}_2 = \frac{1}{2}\dot{x}_1 - \dot{x}_2 + \frac{1}{2}x_2 + \frac{1}{2}\dot{x}_3 + \frac{1}{2}x_3 = 0$$

$$\ddot{x}_3 = \dot{x}_1 + x_1 + \dot{x}_2 + x_2 - 2\dot{x}_3 - 2x_3 + f(t)$$

Define the state variables

$$z_1 = x_1; z_2 = \dot{x}_1; z_3 = x_2; z_4 = \dot{x}_2; z_5 = x_3; z_6 = \dot{x}_3$$

The equations are rewritten as

$$\dot{z}_1 = \dot{x}_1 = z_2$$

$$\dot{z}_2 = \ddot{x}_1 = -2z_2 - z_1 + z_4 + z_6 + z_5$$

$$\dot{z}_3 = \dot{x}_2 = z_4$$

$$\dot{z}_4 = \ddot{x}_2 = \frac{z_1}{2} - z_4 - \frac{z_3}{2} + \frac{z_6}{2} + \frac{z_5}{2}$$

$$\dot{z}_5 = \dot{x}_3 = z_6$$

$$\dot{z}_6 = \ddot{x}_3 = z_2 + z_1 + z_4 + z_3 - 2z_6 - 2z_5$$

In matrix form

$$\dot{\mathbf{z}} = \begin{bmatrix} 0 & 1 & 0 & 0 & 0 & 0 \\ -1 & -2 & 0 & 1 & 1 & 1 \\ 0 & 0 & 0 & 1 & 0 & 0 \\ \frac{1}{2} & 0 & -\frac{1}{2} & -1 & \frac{1}{2} & \frac{1}{2} \\ 0 & 0 & 0 & 0 & 0 & 1 \\ 1 & 1 & 1 & 1 & -2 & -2 \end{bmatrix} \mathbf{z} + \begin{bmatrix} 0 \\ 0 \\ 0 \\ 0 \\ 0 \\ 1 \end{bmatrix} f(t)$$

$$y = [0 \ 0 \ 0 \ 0 \ 1 \ 0] \mathbf{z}$$

6.

Drawing the equivalent network,

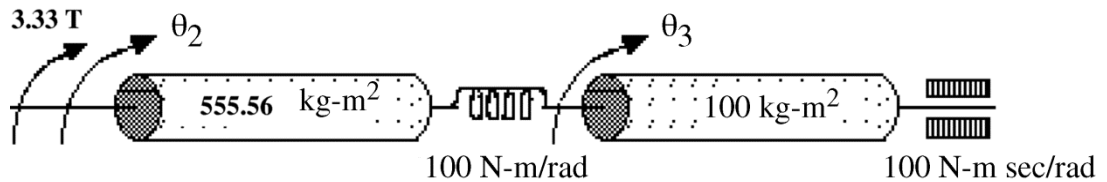

Writing the equations of motion,

$$(555.56s^2 + 100)\theta_2 - 100\theta_3 = 3.33T$$

$$-100\theta_2 + (100s^2 + 100s + 100)\theta_3 = 0$$

Taking the inverse Laplace transform and simplifying,

$$\ddot{\theta}_2 + 0.18\theta_2 - 0.18\theta_3 = 0.006T$$

$$-\theta_2 + \ddot{\theta}_3 + \dot{\theta}_3 + \theta_3 = 0$$

Defining the state variables as

$$x_1 = \theta_2, x_2 = \dot{\theta}_2, x_3 = \theta_3, x_4 = \dot{\theta}_3$$

Writing the state equations using the equations of motion and the definitions of the state variables

$$\begin{aligned} \dot{x}_1 &= x_2 \\ \dot{x}_2 &= \ddot{\theta}_2 = -0.18\theta_2 + 0.18\theta_3 + 0.006T = -0.18x_1 + 0.18x_3 + 0.006T \\ \dot{x}_3 &= x_4 \\ \dot{x}_4 &= \ddot{\theta}_3 = \theta_2 - \theta_3 - \dot{\theta}_3 = x_1 - x_3 - x_4 \\ y &= 3.33\theta_2 = 3.33x_1 \end{aligned}$$

In vector-matrix form,

$$\dot{\mathbf{x}} = \begin{bmatrix} 0 & 1 & 0 & 0 \\ -0.18 & 0 & 0.18 & 0 \\ 0 & 0 & 0 & 1 \\ 1 & 0 & -1 & -1 \end{bmatrix} \mathbf{x} + \begin{bmatrix} 0 \\ 0.006 \\ 0 \\ 0 \end{bmatrix} T$$

$$y = [3.33 \quad 0 \quad 0 \quad 0] \mathbf{x}$$

7.

Drawing the equivalent circuit,

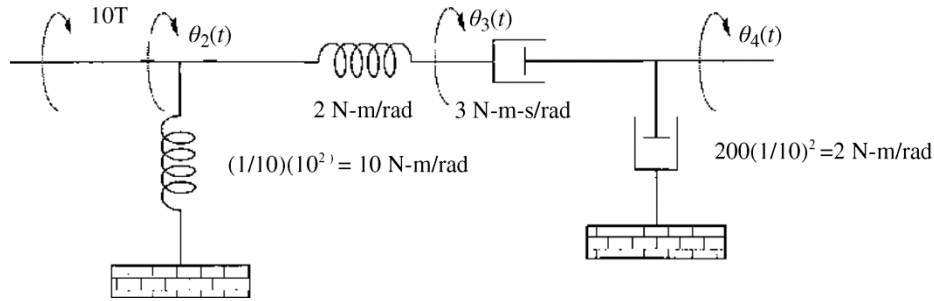

Writing the equations of motion,

$$\begin{aligned} 12\theta_2(s) - 2\theta_3(s) &= 10T(s) \\ -2\theta_2(s) + (3s + 2)\theta_3(s) - 3s\theta_4(s) &= 0 \\ -3s\theta_3(s) + 5s\theta_4(s) &= 0 \end{aligned}$$

Taking the inverse Laplace transform,

$$12\theta_2(t) - 2\theta_3(t) = 10T(t) \quad (1)$$

$$-2\theta_2(t) + 3\dot{\theta}_3(t) + 2\theta_3 - 3\dot{\theta}_4(t) = 0 \quad (2)$$

$$-3\dot{\theta}_3(t) + 5\dot{\theta}_4(t) = 0 \quad (3)$$

From (3),

$$\dot{\theta}_3(t) = \frac{5}{3}\dot{\theta}_4(t) \text{ and } \theta_3(t) = \frac{5}{3}\theta_4(t) \quad (4)$$

assuming zero initial conditions.

From (1)

$$\theta_2(t) = \frac{1}{6}\theta_3(t) + \frac{5}{6}T(t) = \frac{5}{18}\theta_4(t) + \frac{5}{6}T(t) \quad (5)$$

Substituting (4) and (5) into (2) yields the state equation (notice there is only one equation),

$$\dot{\theta}_4(t) = -\frac{25}{18}\theta_4(t) + \frac{5}{6}T(t)$$

The output equation is given by,

$$\theta_L(t) = \frac{1}{10}\theta_4(t)$$

8.

Solving Eqs. (3.44) and (3.45) in the text for the transfer functions $\frac{X_1(s)}{F(s)}$ and $\frac{X_2(s)}{F(s)}$:

$$X_1(s) = \frac{\begin{pmatrix} 0 & -K \\ F & M_2 s^2 + K \end{pmatrix}}{\begin{bmatrix} M_1 s^2 + D s + K & -K \\ -K & M_2 s^2 + K \end{bmatrix}} \quad \text{and} \quad X_2(s) = \frac{\begin{pmatrix} M_1 s^2 + D s + K & 0 \\ -K & F \end{pmatrix}}{\begin{bmatrix} M_1 s^2 + D s + K & -K \\ -K & M_2 s^2 + K \end{bmatrix}}$$

Thus,

$$\frac{X_1(s)}{F(s)} = \frac{K}{M_2 M_1 s^4 + D M_2 s^3 + K M_2 s^2 + K M_1 s^2 + D K s}$$

and

$$\frac{X_2(s)}{F(s)} = \frac{M_1 s^2 + D s + K}{M_2 M_1 s^4 + D M_2 s^3 + K M_2 s^2 + K M_1 s^2 + D K s}$$

Multiplying each of the above transfer functions by s to find velocity yields pole/zero cancellation at the origin and a resulting transfer function that is third order.

9.

a. Using the standard form derived in the textbook,

$$\dot{\mathbf{x}} = \begin{bmatrix} 0 & 1 & 0 & 0 \\ 0 & 0 & 1 & 0 \\ 0 & 0 & 0 & 1 \\ -100 & -7 & -10 & -20 \end{bmatrix} \mathbf{x} + \begin{bmatrix} 0 \\ 0 \\ 0 \\ 1 \end{bmatrix} r(t)$$

$$c = [100 \ 0 \ 0 \ 0] \mathbf{x}$$

b. Using the standard form derived in the textbook,

$$\dot{\mathbf{x}} = \begin{bmatrix} 0 & 1 & 0 & 0 & 0 \\ 0 & 0 & 1 & 0 & 0 \\ 0 & 0 & 0 & 1 & 0 \\ 0 & 0 & 0 & 0 & 1 \\ -30 & -1 & -6 & -9 & -8 \end{bmatrix} \mathbf{x} + \begin{bmatrix} 0 \\ 0 \\ 0 \\ 0 \\ 1 \end{bmatrix} r(t)$$

$$c = [30 \ 0 \ 0 \ 0 \ 0] \mathbf{x}$$

10.

Program:

```
'a'
num=100;
den=[1 20 10 7 100];
G=tf(num,den)
[Acc,Bcc,Ccc,Dcc]=tf2ss(num,den);
Af=flipud(Acc);
A=fliplr(Af)
B=flipud(Bcc)
C=fliplr(Ccc)
'b'
num=30;
```

```

den=[1 8 9 6 1 30];
G=tf(num,den)
[Acc,Bcc,Ccc,Dcc]=tf2ss(num,den);
Af=flipud(Acc);
A=fliplr(Af)
B=flipud(Bcc)
C=fliplr(Ccc)

```

Computer response:

ans =

a

Transfer function:

$$\frac{100}{s^4 + 20 s^3 + 10 s^2 + 7 s + 100}$$

A =

$$\begin{bmatrix} 0 & 1 & 0 & 0 \\ 0 & 0 & 1 & 0 \\ 0 & 0 & 0 & 1 \\ -100 & -7 & -10 & -20 \end{bmatrix}$$

B =

$$\begin{bmatrix} 0 \\ 0 \\ 0 \\ 1 \end{bmatrix}$$

C =

$$\begin{bmatrix} 100 & 0 & 0 & 0 \end{bmatrix}$$

ans =

b

Transfer function:

$$\frac{30}{s^5 + 8 s^4 + 9 s^3 + 6 s^2 + s + 30}$$

A =

$$\begin{bmatrix} 0 & 1 & 0 & 0 & 0 \\ 0 & 0 & 1 & 0 & 0 \\ 0 & 0 & 0 & 1 & 0 \\ 0 & 0 & 0 & 0 & 1 \\ -30 & -1 & -6 & -9 & -8 \end{bmatrix}$$

B =

$$\begin{bmatrix} 0 \\ 0 \\ 0 \\ 0 \\ 1 \end{bmatrix}$$

C =

$$[30 \quad 0 \quad 0 \quad 0 \quad 0]$$

11.

a. Using the standard form derived in the textbook,

$$\dot{\mathbf{x}} = \begin{bmatrix} 0 & 1 & 0 & 0 \\ 0 & 0 & 1 & 0 \\ 0 & 0 & 0 & 1 \\ -13 & -5 & -1 & -5 \end{bmatrix} \mathbf{x} + \begin{bmatrix} 0 \\ 0 \\ 0 \\ 1 \end{bmatrix} r(t)$$

$$c = [10 \quad 8 \quad 0 \quad 0 \quad 0] \mathbf{x}$$

b. Using the standard form derived in the textbook,

$$\dot{\mathbf{x}} = \begin{bmatrix} 0 & 1 & 0 & 0 & 0 \\ 0 & 0 & 1 & 0 & 0 \\ 0 & 0 & 0 & 1 & 0 \\ 0 & 0 & 0 & 0 & 1 \\ 0 & 0 & -8 & -13 & -9 \end{bmatrix} \mathbf{x} + \begin{bmatrix} 0 \\ 0 \\ 0 \\ 0 \\ 1 \end{bmatrix} r(t)$$

$$c = [6 \quad 7 \quad 12 \quad 2 \quad 1] \mathbf{x}$$

12.

Program:

```
'a'
num=[8 10];
den=[1 5 1 5 13]
G=tf(num,den)
[Acc,Bcc,Ccc,Dcc]=tf2ss(num,den);
Af=flipud(Acc);
A=fliplr(Af)
B=flipud(Bcc)
C=fliplr(Ccc)
'b'
num=[1 2 12 7 6];
den=[1 9 13 8 0 0]
G=tf(num,den)
[Acc,Bcc,Ccc,Dcc]=tf2ss(num,den);
Af=flipud(Acc);
```

```
A=fliplr(Af)
B=flipud(Bcc)
C=fliplr(Ccc)
```

Computer response:

```
ans =
```

```
ans =
```

```
a
```

```
den =
```

```
1 5 1 5 13
```

```
Transfer function:
```

```
8 s + 10
```

```
-----
s^4 + 5 s^3 + s^2 + 5 s + 13
```

```
A =
```

```
0 1 0 0
0 0 1 0
0 0 0 1
-13 -5 -1 -5
```

```
B =
```

```
0
0
0
1
```

```
C =
```

```
10 8 0 0
```

```
ans =
```

```
b
```

```
den =
```

```
1 9 13 8 0 0
```