

2.1. (a) $T(x[n]) = g[n]x[n]$

- **Stable:** Let $|x[n]| \leq M$ then $|T(x[n])| \leq |g[n]|M$. So, it is stable if $|g[n]|$ is bounded.
- **Causal:** $y_1[n] = g[n]x_1[n]$ and $y_2[n] = g[n]x_2[n]$, so if $x_1[n] = x_2[n]$ for all $n < n_0$, then $y_1[n] = y_2[n]$ for all $n < n_0$, and the system is causal.
- **Linear:**

$$\begin{aligned} T(ax_1[n] + bx_2[n]) &= g[n](ax_1[n] + bx_2[n]) \\ &= ag[n]x_1[n] + bg[n]x_2[n] \\ &= aT(x_1[n]) + bT(x_2[n]) \end{aligned}$$

So this is linear.

- **Not time-invariant:**

$$\begin{aligned} T(x[n - n_0]) &= g[n]x[n - n_0] \\ &\neq y[n - n_0] = g[n - n_0]x[n - n_0] \end{aligned}$$

which is not TI.

- **Memoryless:** $y[n] = T(x[n])$ depends only on the n^{th} value of x , so it is memoryless.

(b) $T(x[n]) = \sum_{k=n_0}^n x[k]$

- **Not Stable:** $|x[n]| \leq M \rightarrow |T(x[n])| \leq \sum_{k=n_0}^n |x[k]| \leq |n - n_0|M$. As $n \rightarrow \infty$, $T \rightarrow \infty$, so not stable.
- **Not Causal:** $T(x[n])$ depends on the future values of $x[n]$ when $n < n_0$, so this is not causal.
- **Linear:**

$$\begin{aligned} T(ax_1[n] + bx_2[n]) &= \sum_{k=n_0}^n ax_1[k] + bx_2[k] \\ &= a \sum_{k=n_0}^n x_1[k] + b \sum_{k=n_0}^n x_2[k] \\ &= aT(x_1[n]) + bT(x_2[n]) \end{aligned}$$

The system is linear.

- **Not TI:**

$$\begin{aligned} T(x[n - n_0]) &= \sum_{k=n_0}^n x[k - n_0] \\ &= \sum_{k=0}^{n-n_0} x[k] \\ &\neq y[n - n_0] = \sum_{k=n_0}^{n-n_0} x[k] \end{aligned}$$

The system is not TI.

- **Not Memoryless:** Values of $y[n]$ depend on past values for $n > n_0$, so this is not memoryless.

(c) $T(x[n]) = \sum_{k=n-n_0}^{n+n_0} x[k]$

- **Stable:** $|T(x[n])| \leq \sum_{k=n-n_0}^{n+n_0} |x[k]| \leq \sum_{k=n-n_0}^{n+n_0} x[k]M \leq |2n_0 + 1|M$ for $|x[n]| \leq M$, so it is stable.
- **Not Causal:** $T(x[n])$ depends on future values of $x[n]$, so it is not causal.
- **Linear:**

$$\begin{aligned} T(ax_1[n] + bx_2[n]) &= \sum_{k=n-n_0}^{n+n_0} ax_1[k] + bx_2[k] \\ &= a \sum_{k=n-n_0}^{n+n_0} x_1[k] + b \sum_{k=n-n_0}^{n+n_0} x_2[k] = aT(x_1[n]) + bT(x_2[n]) \end{aligned}$$

This is linear.

- TI:

$$\begin{aligned} T(x[n - n_0]) &= \sum_{k=n-n_0}^{n+n_0} x[k - n_0] \\ &= \sum_{k=n-n_0}^n x[k] \\ &= y[n - n_0] \end{aligned}$$

This is TI.

- Not memoryless: The values of $y[n]$ depend on $2n_0$ other values of x , not memoryless.

(d) $T(x[n]) = x[n - n_0]$

- Stable: $|T(x[n])| = |x[n - n_0]| \leq M$ if $|x[n]| \leq M$, so stable.
- Causality: If $n_0 \geq 0$, this is causal, otherwise it is not causal.
- Linear:

$$\begin{aligned} T(ax_1[n] + bx_2[n]) &= ax_1[n - n_0] + bx_2[n - n_0] \\ &= aT(x_1[n]) + bT(x_2[n]) \end{aligned}$$

This is linear.

- TI: $T(x[n - n_d]) = x[n - n_0 - n_d] = y[n - n_d]$. This is TI.
- Not memoryless: Unless $n_0 = 0$, this is not memoryless.

(e) $T(x[n]) = e^{x[n]}$

- Stable: $|x[n]| \leq M$, $|T(x[n])| = |e^{x[n]}| \leq e^{|x[n]|} \leq e^M$, this is stable.
- Causal: It doesn't use future values of $x[n]$, so it is causal.
- Not linear:

$$\begin{aligned} T(ax_1[n] + bx_2[n]) &= e^{ax_1[n] + bx_2[n]} \\ &= e^{ax_1[n]} e^{bx_2[n]} \\ &\neq aT(x_1[n]) + bT(x_2[n]) \end{aligned}$$

This is not linear.

- TI: $T(x[n - n_0]) = e^{x[n - n_0]} = y[n - n_0]$, so this is TI.
- Memoryless: $y[n]$ depends on the n^{th} value of x only, so it is memoryless.

(f) $T(x[n]) = ax[n] + b$

- Stable: $|T(x[n])| = |ax[n] + b| \leq a|M| + |b|$, which is stable for finite a and b .
- Causal: This doesn't use future values of $x[n]$, so it is causal.
- Not linear:

$$\begin{aligned} T(cx_1[n] + dx_2[n]) &= acx_1[n] + adx_2[n] + b \\ &\neq cT(x_1[n]) + dT(x_2[n]) \end{aligned}$$

This is not linear.

- **TI:** $T(x[n - n_0]) = ax[n - n_0] + b = y[n - n_0]$. It is TI.
- **Memoryless:** $y[n]$ depends on the n^{th} value of $x[n]$ only, so it is memoryless.

(g) $T(x[n]) = x[-n]$

- **Stable:** $|T(x[n])| \leq |x[-n]| \leq M$, so it is stable.
- **Not causal:** For $n < 0$, it depends on the future value of $x[n]$, so it is not causal.
- **Linear:**

$$\begin{aligned} T(ax_1[n] + bx_2[n]) &= ax_1[-n] + bx_2[-n] \\ &= aT(x_1[n]) + bT(x_2[n]) \end{aligned}$$

This is linear.

- **Not TI:**

$$\begin{aligned} T(x[n - n_0]) &= x[-n - n_0] \\ &\neq y[n - n_0] = x[-n + n_0] \end{aligned}$$

This is not TI.

- **Not memoryless:** For $n \neq 0$, it depends on a value of x other than the n^{th} value, so it is not memoryless.

(h) $T(x[n]) = x[n] + u[n + 1]$

- **Stable:** $|T(x[n])| \leq M + 3$ for $n \geq -1$ and $|T(x[n])| \leq M$ for $n < -1$, so it is stable.
- **Causal:** Since it doesn't use future values of $x[n]$, it is causal.
- **Not linear:**

$$\begin{aligned} T(ax_1[n] + bx_2[n]) &= ax_1[n] + bx_2[n] + 3u[n + 1] \\ &\neq aT(x_1[n]) + bT(x_2[n]) \end{aligned}$$

This is not linear.

- **Not TI:**

$$\begin{aligned} T(x[n - n_0]) &= x[n - n_0] + 3u[n + 1] \\ &= y[n - n_0] \\ &= x[n - n_0] + 3u[n - n_0 + 1] \end{aligned}$$

This is not TI.

- **Memoryless:** $y[n]$ depends on the n^{th} value of x only, so this is memoryless.

2.2. For an LTI system, the output is obtained from the convolution of the input with the impulse response of the system:

$$y[n] = \sum_{k=-\infty}^{\infty} h[k]x[n-k]$$

(a) Since $h[k] \neq 0$, for $(N_0 \leq n \leq N_1)$,

$$y[n] = \sum_{k=N_0}^{N_1} h[k]x[n-k]$$

The input, $x[n] \neq 0$, for $(N_2 \leq n \leq N_3)$, so

$$x[n-k] \neq 0, \text{ for } N_2 \leq (n-k) \leq N_3$$

Note that the minimum value of $(n-k)$ is N_2 . Thus, the lower bound on n , which occurs for $k = N_0$ is

$$N_4 = N_0 + N_2.$$

Using a similar argument,

$$N_5 = N_1 + N_3.$$

Therefore, the output is nonzero for

$$(N_0 + N_2) \leq n \leq (N_1 + N_3).$$

(b) If $x[n] \neq 0$, for some $n_o \leq n \leq (n_o + N - 1)$, and $h[n] \neq 0$, for some $n_1 \leq n \leq (n_1 + M - 1)$, the results of part (a) imply that the output is nonzero for:

$$(n_o + n_1) \leq n \leq (n_o + n_1 + M + N - 2)$$

So the output sequence is $M + N - 1$ samples long. This is an important quality of the convolution for finite length sequences as we shall see in Chapter 8.

2.3. We desire the step response to a system whose impulse response is

$$h[n] = a^{-n}u[-n], \text{ for } 0 < a < 1.$$

The convolution sum:

$$y[n] = \sum_{k=-\infty}^{\infty} h[k]x[n-k]$$

The step response results when the input is the unit step:

$$x[n] = u[n] = \begin{cases} 1, & \text{for } n \geq 0 \\ 0, & \text{for } n < 0 \end{cases}$$

Substitution into the convolution sum yields

$$y[n] = \sum_{k=-\infty}^{\infty} a^{-k}u[-k]u[n-k]$$

For $n \leq 0$:

$$\begin{aligned} y[n] &= \sum_{k=-\infty}^{\infty} a^{-k} \\ &= \sum_{k=-n}^{\infty} a^k \\ &= \frac{a^{-n}}{1-a} \end{aligned}$$

For $n > 0$:

$$\begin{aligned} y[n] &= \sum_{k=-\infty}^0 a^{-k} \\ &= \sum_{k=0}^{\infty} a^k \\ &= \frac{1}{1-a} \end{aligned}$$

2.4. The difference equation:

$$y[n] - \frac{3}{4}y[n-1] + \frac{1}{8}y[n-2] = 2x[n-1]$$

To solve, we take the Fourier transform of both sides.

$$Y(e^{j\omega}) - \frac{3}{4}Y(e^{j\omega})e^{-j\omega} + \frac{1}{8}Y(e^{j\omega})e^{-j2\omega} = 2 \cdot X(e^{j\omega})e^{-j\omega}$$

The system function is given by:

$$\begin{aligned} H(e^{j\omega}) &= \frac{Y(e^{j\omega})}{X(e^{j\omega})} \\ &= \frac{2e^{-j\omega}}{1 - \frac{3}{4}e^{-j\omega} + \frac{1}{8}e^{-j2\omega}} \end{aligned}$$

The impulse response (for $x[n] = \delta[n]$) is the inverse Fourier transform of $H(e^{j\omega})$.

$$H(e^{j\omega}) = \frac{-8}{1 + \frac{1}{4}e^{-j\omega}} + \frac{8}{1 - \frac{1}{2}e^{-j\omega}}$$

Thus,

$$h[n] = -8\left(\frac{1}{4}\right)^n u[n] + 8\left(\frac{1}{2}\right)^n u[n].$$

2.5. (a) The homogeneous difference equation:

$$y[n] - 5y[n-1] + 6y[n-2] = 0$$

Taking the Z -transform,

$$\begin{aligned} 1 - 5z^{-1} + 6z^{-2} &= 0 \\ (1 - 2z^{-1})(1 - 3z^{-1}) &= 0. \end{aligned}$$

The homogeneous solution is of the form

$$y_h[n] = A_1(2)^n + A_2(3)^n.$$

(b) We take the z -transform of both sides:

$$Y(z)[1 - 5z^{-1} + 6z^{-2}] = 2z^{-1}X(z)$$

Thus, the system function is

$$\begin{aligned} H(z) &= \frac{Y(z)}{X(z)} \\ &= \frac{2z^{-1}}{1 - 5z^{-1} + 6z^{-2}} \\ &= \frac{-2}{1 - 2z^{-1}} + \frac{2}{1 - 3z^{-1}}, \end{aligned}$$

where the region of convergence is outside the outermost pole, because the system is causal. Hence the ROC is $|z| > 3$. Taking the inverse z -transform, the impulse response is

$$h[n] = -2(2)^n u[n] + 2(3)^n u[n].$$

(c) Let $x[n] = u[n]$ (unit step), then

$$X(z) = \frac{1}{1 - z^{-1}}$$

and

$$\begin{aligned} Y(z) &= X(z) \cdot H(z) \\ &= \frac{2z^{-1}}{(1 - z^{-1})(1 - 2z^{-1})(1 - 3z^{-1})}. \end{aligned}$$

Partial fraction expansion yields

$$Y(z) = \frac{1}{1 - z^{-1}} - \frac{4}{1 - 2z^{-1}} + \frac{3}{1 - 3z^{-1}}.$$

The inverse transform yields:

$$y[n] = u[n] - 4(2)^n u[n] + 3(3)^n u[n].$$

2.6. (a) The difference equation:

$$y[n] - \frac{1}{2}y[n-1] = x[n] + 2x[n-1] + x[n-2]$$

Taking the Fourier transform of both sides,

$$Y(e^{j\omega})[1 - \frac{1}{2}e^{-j\omega}] = X(e^{j\omega})[1 + 2e^{-j\omega} + e^{-j2\omega}].$$

Hence, the frequency response is

$$\begin{aligned} H(e^{j\omega}) &= \frac{Y(e^{j\omega})}{X(e^{j\omega})} \\ &= \frac{1 + 2e^{-j\omega} + e^{-j2\omega}}{1 - \frac{1}{2}e^{-j\omega}}. \end{aligned}$$

(b) A system with frequency response:

$$\begin{aligned} H(e^{j\omega}) &= \frac{1 - \frac{1}{2}e^{-j\omega} + e^{-j3\omega}}{1 + \frac{1}{2}e^{-j\omega} + \frac{3}{4}e^{-j2\omega}} \\ &= \frac{Y(e^{j\omega})}{X(e^{j\omega})} \end{aligned}$$

cross multiplying,

$$Y(e^{j\omega})[1 + \frac{1}{2}e^{-j\omega} + \frac{3}{4}e^{-j2\omega}] = X(e^{j\omega})[1 - \frac{1}{2}e^{-j\omega} + e^{-j3\omega}],$$

and the inverse transform gives

$$y[n] + \frac{1}{2}y[n-1] + \frac{3}{4}y[n-2] = x[n] - \frac{1}{2}x[n-1] + x[n-3].$$

2.7. $x[n]$ is periodic with period N if $x[n] = x[n + N]$ for some integer N .

(a) $x[n]$ is periodic with period 12:

$$e^{j(\frac{\pi}{6}n)} = e^{j(\frac{\pi}{6})(n+N)} = e^{j(\frac{\pi}{6}n+2\pi k)}$$

$$\implies 2\pi k = \frac{\pi}{6}N, \text{ for integers } k, N$$

Making $k = 1$ and $N = 12$ shows that $x[n]$ has period 12.

(b) $x[n]$ is periodic with period 8:

$$e^{j(\frac{3\pi}{4}n)} = e^{j(\frac{3\pi}{4})(n+N)} = e^{j(\frac{3\pi}{4}n+2\pi k)}$$

$$\implies 2\pi k = \frac{3\pi}{4}N, \text{ for integers } k, N$$

$$\implies N = \frac{8}{3}k, \text{ for integers } k, N$$

The smallest k for which both k and N are integers are is 3, resulting in the period N being 8.

(c) $x[n] = [\sin(\pi n/5)]/(\pi n)$ is not periodic because the denominator term is linear in n .

(d) We will show that $x[n]$ is not periodic. Suppose that $x[n]$ is periodic for some period N :

$$e^{j(\frac{\pi}{\sqrt{2}}n)} = e^{j(\frac{\pi}{\sqrt{2}})(n+N)} = e^{j(\frac{\pi}{\sqrt{2}}n+2\pi k)}$$

$$\implies 2\pi k = \frac{\pi}{\sqrt{2}}N, \text{ for integers } k, N$$

$$\implies N = 2\sqrt{2}k, \text{ for some integers } k, N$$

There is no integer k for which N is an integer. Hence $x[n]$ is not periodic.

2.8. We take the Fourier transform of both $h[n]$ and $x[n]$, and then use the fact that convolution in the time domain is the same as multiplication in the frequency domain.

$$\begin{aligned}H(e^{j\omega}) &= \frac{5}{1 + \frac{1}{2}e^{-j\omega}} \\Y(e^{j\omega}) &= H(e^{j\omega})X(e^{j\omega}) \\&= \frac{5}{1 + \frac{1}{2}e^{-j\omega}} \cdot \frac{1}{1 - \frac{1}{3}e^{-j\omega}} \\&= \frac{3}{1 + \frac{1}{2}e^{-j\omega}} + \frac{2}{1 - \frac{1}{3}e^{-j\omega}} \\y[n] &= 2\left(\frac{1}{3}\right)^n u[n] + 3\left(-\frac{1}{2}\right)^n u[n]\end{aligned}$$

2.9. (a) First the frequency response:

$$Y(e^{j\omega}) - \frac{5}{6}e^{-j\omega}Y(e^{j\omega}) + \frac{1}{6}e^{-2j\omega}Y(e^{j\omega}) = \frac{1}{3}e^{-2j\omega}X(e^{j\omega})$$

$$\begin{aligned} H(e^{j\omega}) &= \frac{Y(e^{j\omega})}{X(e^{j\omega})} \\ &= \frac{\frac{1}{3}e^{-2j\omega}}{1 - \frac{5}{6}e^{-j\omega} + \frac{1}{6}e^{-2j\omega}} \end{aligned}$$

Now we take the inverse Fourier transform to find the impulse response:

$$\begin{aligned} H(e^{j\omega}) &= \frac{-2}{1 - \frac{1}{3}e^{-j\omega}} + \frac{2}{1 - \frac{1}{2}e^{-j\omega}} \\ h[n] &= -2\left(\frac{1}{3}\right)^n u[n] + 2\left(\frac{1}{2}\right)^n u[n] \end{aligned}$$

For the step response $s[n]$:

$$\begin{aligned} s[n] &= \sum_{k=-\infty}^{\infty} h[k]u[n-k] \\ &= \sum_{k=-\infty}^n h[k] \\ &= -2\frac{1 - (1/3)^{n+1}}{1 - 1/3}u[n] + 2\frac{1 - (1/2)^{n+1}}{1 - 1/2}u[n] \\ &= \left(1 + \left(\frac{1}{3}\right)^n - 2\left(\frac{1}{2}\right)^n\right)u[n] \end{aligned}$$

(b) The homogeneous solution $y_h[n]$ solves the difference equation when $x[n] = 0$. It is in the form $y_h[n] = \sum A(c)^n$, where the c 's solve the quadratic equation

$$c^2 - \frac{5}{6}c + \frac{1}{6} = 0$$

So for $c = 1/2$ and $c = 1/3$, the general form for the homogeneous solution is:

$$y_h[n] = A_1\left(\frac{1}{2}\right)^n + A_2\left(\frac{1}{3}\right)^n$$

(c) The total solution is the sum of the homogeneous and particular solutions, with the particular solution being the impulse response found in part (a):

$$\begin{aligned} y[n] &= y_h[n] + y_p[n] \\ &= A_1\left(\frac{1}{2}\right)^n + A_2\left(\frac{1}{3}\right)^n - 2\left(\frac{1}{3}\right)^n u[n] + 2\left(\frac{1}{2}\right)^n u[n] \end{aligned}$$

Now we use the constraint $y[0] = y[1] = 1$ to solve for A_1 and A_2 :

$$\begin{aligned} y[0] &= A_1 + A_2 - 2 + 2 = 1 \\ y[1] &= A_1/2 + A_2/3 - 2/3 + 1 = 1 \\ A_1 + A_2 &= 1 \\ A_1/2 + A_2/3 &= 2/3 \end{aligned}$$

With $A_1 = 2$ and $A_2 = -1$ solving the simultaneous equations, we find that the impulse response is

$$y[n] = 2\left(\frac{1}{2}\right)^n - \left(\frac{1}{3}\right)^n - 2\left(\frac{1}{3}\right)^n u[n] + 2\left(\frac{1}{2}\right)^n u[n]$$

2.10. (a)

$$\begin{aligned}
 y[n] &= h[n] * x[n] \\
 &= \sum_{k=-\infty}^{\infty} a^k u[-k-1] u[n-k] \\
 &= \begin{cases} \sum_{k=-\infty}^n a^k, & n \leq -1 \\ \sum_{k=-\infty}^{-1} a^k, & n > -1 \end{cases} \\
 &= \begin{cases} \frac{a^n}{1-1/a}, & n \leq -1 \\ \frac{1/a}{1-1/a}, & n > -1 \end{cases}
 \end{aligned}$$

(b) First, let us define $v[n] = 2^n u[-n-1]$. Then, from part (a), we know that

$$w[n] = u[n] * v[n] = \begin{cases} 2^{n+1}, & n \leq -1 \\ 1, & n > -1 \end{cases}$$

Now,

$$\begin{aligned}
 y[n] &= u[n-4] * v[n] \\
 &= w[n-4] \\
 &= \begin{cases} 2^{n-3}, & n \leq 3 \\ 1, & n > 3 \end{cases}
 \end{aligned}$$

(c) Given the same definitions for $v[n]$ and $w[n]$ from part(b), we use the fact that $h[n] = 2^{n-1} u[-(n-1)-1] = v[n-1]$ to reduce our work:

$$\begin{aligned}
 y[n] &= x[n] * h[n] \\
 &= x[n] * v[n-1] \\
 &= w[n-1] \\
 &= \begin{cases} 2^n, & n \leq 0 \\ 1, & n > 0 \end{cases}
 \end{aligned}$$

(d) Again, we use $v[n]$ and $w[n]$ to help us.

$$\begin{aligned}
 y[n] &= x[n] * h[n] \\
 &= (u[n] - u[n-10]) * v[n] \\
 &= w[n] - w[n-10] \\
 &= (2^{n+1} u[-(n+1)] + u[n]) - (2^{n-9} u[-(n-9)] + u[n-10]) \\
 &= \begin{cases} 2^{(n+1)} - 2^{(n-9)}, & n \leq -2 \\ 1 - 2^{(n-9)}, & -1 \leq n \leq 8 \\ 0, & n \geq 9 \end{cases}
 \end{aligned}$$

2.11. First we re-write $x[n]$ as a sum of complex exponentials:

$$x[n] = \sin\left(\frac{\pi n}{4}\right) = \frac{e^{j\pi n/4} - e^{-j\pi n/4}}{2j}.$$

Since complex exponentials are eigenfunctions of LTI systems,

$$y[n] = \frac{H(e^{j\pi/4})e^{j\pi n/4} - H(e^{-j\pi/4})e^{-j\pi n/4}}{2j}$$

Evaluating the frequency response at $\omega = \pm\pi/4$:

$$H(e^{j\pi/4}) = \frac{1 - e^{-j\pi/2}}{1 + 1/2e^{-j\pi}} = 2(1 - j) = 2\sqrt{2}e^{-j\pi/4}$$

$$H(e^{-j\pi/4}) = \frac{1 - e^{j\pi/2}}{1 + 1/2e^{j\pi}} = 2(1 + j) = 2\sqrt{2}e^{j\pi/4}$$

We get:

$$\begin{aligned} y[n] &= \frac{2\sqrt{2}e^{-j\pi/4}e^{j\pi n/4} - 2\sqrt{2}e^{j\pi/4}e^{-j\pi n/4}}{2j} \\ &= 2\sqrt{2}\sin(\pi n/4 - \pi/4). \end{aligned}$$

2.12. The difference equation:

$$y[n] = ny[n-1] + x[n]$$

Since the system is causal and satisfies initial-rest conditions, we may recursively find the response to any input.

(a) Suppose $x[n] = \delta[n]$:

$$y[n] = 0, \text{ for } n < 0$$

$$y[0] = 1$$

$$y[1] = 1$$

$$y[2] = 2$$

$$y[3] = 6$$

$$y[4] = 24$$

$$y[n] = h[n] = n!u[n]$$

(b) To determine if the system is linear, consider the input:

$$x[n] = a\delta[n] + b\delta[n]$$

performing the recursion,

$$y[n] = 0, \text{ for } n < 0$$

$$y[0] = a + b$$

$$y[1] = a + b$$

$$y[2] = 2(a + b)$$

$$y[3] = 6(a + b)$$

$$y[4] = 24(a + b)$$

Because the output of the superposition of two input signals is equivalent to the superposition of the individual outputs, the system is LINEAR.

(c) To determine if the system is time-invariant, consider the input:

$$x[n] = \delta[n-1]$$

the recursion yields

$$y[n] = 0, \text{ for } n < 0$$

$$y[0] = 0$$

$$y[1] = 1$$

$$y[2] = 2$$

$$y[3] = 6$$

$$y[4] = 24$$

Using $h[n]$ from part (a),

$$h[n-1] = (n-1)!u[n-1] \neq y[n]|_{x[n]=\delta[n-1]}$$

Conclude: NOT TIME INVARIANT.

© 2009 by Oppenheim. Published by Pearson Prentice Hall, Pearson Education, Inc., Upper Saddle River, NJ. All rights reserved. This material is protected under all copyright laws as they currently exist. No portion of this material may be reproduced, in any form or by any means, without permission in writing from the publisher.

2.13. Eigenfunctions of LTI systems are of the form α^n , so functions (a), (b), and (e) are eigenfunctions.

Notice that part (d), $\cos(\omega_0 n) = .5(e^{j\omega_0 n} + e^{-j\omega_0 n})$ is a sum of two α^n functions, and is therefore not an eigenfunction itself.

- 2.14.** (a) The information given shows that the system satisfies the eigenfunction property of exponential sequences for LTI systems for one particular eigenfunction input. However, we do not know the system response for any other eigenfunction. Hence, we can say that the system may be LTI, but we cannot uniquely determine it. \Rightarrow (iv).
- (b) If the system were LTI, the output should be in the form of $A(1/2)^n$, since $(1/2)^n$ would have been an eigenfunction of the system. Since this is not true, the system cannot be LTI. \Rightarrow (i).
- (c) Given the information, the system *may* be LTI, but does not have to be. For example, for any input other than the given one, the system may output 0, making this system non-LTI. \Rightarrow (iii).
If it were LTI, its system function can be found by using the DTFT:

$$\begin{aligned}H(e^{j\omega}) &= \frac{Y(e^{j\omega})}{X(e^{j\omega})} \\ &= \frac{1}{1 - \frac{1}{2}e^{-j\omega}} \\ h[n] &= \left(\frac{1}{2}\right)^n u[n]\end{aligned}$$

2.15. (a) No. Consider the following input/outputs:

$$x_1[n] = \delta[n] \implies y_1[n] = \left(\frac{1}{4}\right)^n u[n]$$

$$x_2[n] = \delta[n - 1] \implies y_2[n] = \left(\frac{1}{4}\right)^{n-1} u[n]$$

Even though $x_2[n] = x_1[n - 1]$, $y_2[n] \neq y_1[n - 1] = \left(\frac{1}{4}\right)^{n-1} u[n - 1]$

- (b) No. Consider the input/output pair $x_2[n]$ and $y_2[n]$ above. $x_2[n] = 0$ for $n < 1$, but $y_2[0] \neq 0$.
- (c) Yes. Since $h[n]$ is stable and multiplication with $u[n]$ will not cause any sequences to become unbounded, the entire system is stable.

- 2.16. (a) The homogeneous solution $y_h[n]$ solves the difference equation when $x[n] = 0$. It is in the form $y_h[n] = \sum A(c)^n$, where the c 's solve the quadratic equation

$$c^2 - \frac{1}{4}c + \frac{1}{8} = 0$$

So for $c = 1/2$ and $c = -1/4$, the general form for the homogeneous solution is:

$$y_h[n] = A_1\left(\frac{1}{2}\right)^n + A_2\left(-\frac{1}{4}\right)^n$$

- (b) Taking the z -transform of both sides, we find that

$$Y(z)\left(1 - \frac{1}{4}z^{-1} - \frac{1}{8}z^{-2}\right) = 3X(z)$$

and therefore

$$\begin{aligned} H(z) &= \frac{Y(z)}{X(z)} \\ &= \frac{3}{1 - 1/4z^{-1} - 1/8z^{-2}} \\ &= \frac{3}{(1 + 1/4z^{-1})(1 - 1/2z^{-1})} \\ &= \frac{1}{1 + 1/4z^{-1}} + \frac{2}{1 - 1/2z^{-1}} \end{aligned}$$

The causal impulse response corresponds to assuming that the region of convergence extends outside the outermost pole, making

$$h_c[n] = \left(-\frac{1}{4}\right)^n + 2\left(\frac{1}{2}\right)^n u[n]$$

The anti-causal impulse response corresponds to assuming that the region of convergence is inside the innermost pole, making

$$h_{ac}[n] = -\left(-\frac{1}{4}\right)^n + 2\left(\frac{1}{2}\right)^n u[-n - 1]$$

- (c) $h_c[n]$ is absolutely summable, while $h_{ac}[n]$ grows without bounds.

- (d)

$$\begin{aligned} Y(z) &= X(z)H(z) \\ &= \frac{1}{1 - \frac{1}{2}z^{-1}} \cdot \frac{1}{(1 + \frac{1}{4}z^{-1})(1 - \frac{1}{2}z^{-1})} \\ &= \frac{1/3}{1 + 1/4z^{-1}} + \frac{2}{1 - 1/2z^{-1}} + \frac{2/3}{1 - 1/2z^{-1}} \\ y[n] &= \frac{1}{3}\left(\frac{1}{4}\right)^n u[n] + 4(n+1)\left(\frac{1}{2}\right)^{n+1} u[n+1] + \frac{2}{3}\left(\frac{1}{2}\right)^n u[n] \end{aligned}$$

2.17. (a) We have

$$r[n] = \begin{cases} 1, & \text{for } 0 \leq n \leq M \\ 0, & \text{otherwise} \end{cases}$$

Taking the Fourier transform

$$\begin{aligned} R(e^{j\omega}) &= \sum_{n=0}^M e^{-j\omega n} \\ &= \frac{1 - e^{-j\omega(M+1)}}{1 - e^{-j\omega}} \\ &= e^{-j\frac{M}{2}\omega} \left(\frac{e^{j\frac{M+1}{2}\omega} - e^{-j\frac{M+1}{2}\omega}}{e^{j\omega} - e^{-j\omega}} \right) \\ &= e^{-j\frac{M}{2}\omega} \left(\frac{\sin(\frac{M+1}{2}\omega)}{\sin(\omega/2)} \right) \end{aligned}$$

(b) We have

$$w[n] = \begin{cases} \frac{1}{2}(1 + \cos(\frac{2\pi n}{M})), & \text{for } 0 \leq n \leq M \\ 0, & \text{otherwise} \end{cases}$$

We note that,

$$w[n] = r[n] \cdot \frac{1}{2} [1 + \cos(\frac{2\pi n}{M})].$$

Thus,

$$\begin{aligned} W(e^{j\omega}) &= R(e^{j\omega}) * \sum_{n=-\infty}^{\infty} \frac{1}{2} (1 + \cos(\frac{2\pi n}{M})) e^{-j\omega n} \\ &= R(e^{j\omega}) * \sum_{n=-\infty}^{\infty} \frac{1}{2} (1 + \frac{1}{2} e^{j\frac{2\pi n}{M}} + \frac{1}{2} e^{-j\frac{2\pi n}{M}}) e^{-j\omega n} \\ &= R(e^{j\omega}) * (\frac{1}{2}\delta(\omega) + \frac{1}{4}\delta(\omega + \frac{2\pi}{M}) + \frac{1}{4}\delta(\omega - \frac{2\pi}{M})) \end{aligned}$$

(c)

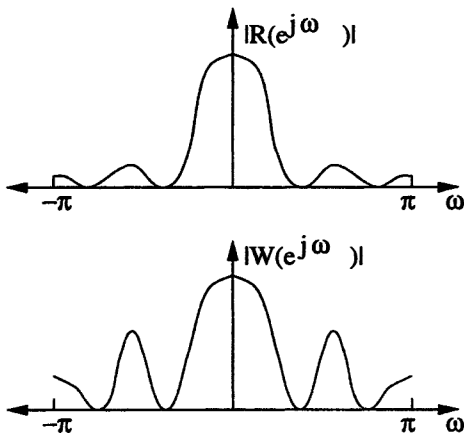

© 2010 by Oppenheim. Published by Pearson Prentice Hall, Pearson Education, Inc., Upper Saddle River, NJ. All rights reserved. This material is protected under all copyright laws as they currently exist. No portion of this material may be reproduced, in any form or by any means, without permission in writing from the publisher.

2.18. $h[n]$ is causal if $h[n] = 0$ for $n < 0$. Hence, (a) and (b) are causal, while (c), (d), and (e) are not.

2.19. $h[n]$ is stable if it is absolutely summable.

(a) Not stable because $h[n]$ goes to ∞ as n goes to ∞ .

(b) Stable, because $h[n]$ is non-zero only for $0 \leq n \leq 9$.

(c) Stable.

$$\sum_n |h[n]| = \sum_{n=-\infty}^{-1} 3^n = \sum_{n=1}^{\infty} (1/3)^n = 1/2 < \infty$$

(d) Not stable. Notice that

$$\sum_{n=0}^5 |\sin(\pi n/3)| = 2\sqrt{3}$$

and summing $|h[n]|$ over all positive n therefore grows to ∞ .

(e) Stable. Notice that $|h[n]|$ is upperbounded by $(3/4)^{|n|}$, which is absolutely summable.

(f) Stable.

$$h[n] = \begin{cases} 2, & -5 \leq n \leq -1 \\ 1, & 0 \leq n \leq 4 \\ 0, & \text{otherwise} \end{cases}$$

So $\sum |h[n]| = 15$.

2.20. (a) Taking the difference equation $y[n] = (1/a)y[n-1] + x[n-1]$ and assuming $h[0] = 0$ for $n < 0$:

$$h[0] = 0$$

$$h[1] = 1$$

$$h[2] = 1/a$$

$$h[3] = (1/a)^2$$

$$\vdots$$

$$h[n] = (1/a)^{n-1}u[n-1]$$

(b) $h[n]$ is absolutely summable if $|1/a| < 1$ or if $|a| > 1$

© 2010 by Oppenheim. Published by Pearson Prentice Hall, Pearson Education, Inc., Upper Saddle River, NJ. All rights reserved. This material is protected under all copyright laws as they currently exist. No portion of this material may be reproduced, in any form or by any means, without permission in writing from the publisher.

2.21.

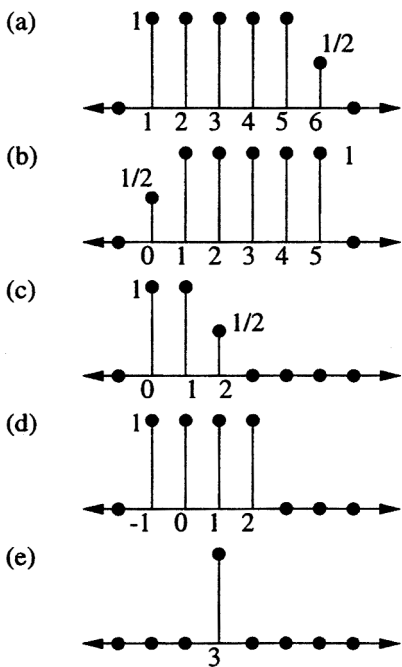

2.22. For an LTI system, we use the convolution equation to obtain the output:

$$y[n] = \sum_{k=-\infty}^{\infty} x[n-k]h[k]$$

Let $n = m + N$:

$$\begin{aligned} y[m+N] &= \sum_{k=-\infty}^{\infty} x[m+N-k]h[k] \\ &= \sum_{k=-\infty}^{\infty} x[(m-k)+N]h[k] \end{aligned}$$

Since $x[n]$ is periodic, $x[n] = x[n+rN]$ for any integer r . Hence,

$$\begin{aligned} y[m+N] &= \sum_{k=-\infty}^{\infty} x[m-k]h[k] \\ &= y[m] \end{aligned}$$

So, the output must also be periodic with period N .

2.23. (a) Since $\cos(\pi n)$ only takes on values of $+1$ or -1 , this transformation outputs the current value of $x[n]$ multiplied by either ± 1 . $T(x[n]) = (-1)^n x[n]$.

- Hence, it is stable, because it doesn't change the magnitude of $x[n]$ and hence satisfies bounded-in/bounded-out stability.
- It is causal, because each output depends only on the current value of $x[n]$.
- It is linear. Let $y_1[n] = T(x_1[n]) = \cos(\pi n)x_1[n]$, and $y_2[n] = T(x_2[n]) = \cos(\pi n)x_2[n]$. Now

$$T(ax_1[n] + bx_2[n]) = \cos(\pi n)(ax_1[n] + bx_2[n]) = ay_1[n] + by_2[n]$$

- It is not time-invariant. If $y[n] = T(x[n]) = (-1)^n x[n]$, then $T(x[n-1]) = (-1)^n x[n-1] \neq y[n-1]$.

(b) This transformation simply "samples" $x[n]$ at location which can be expressed as k^2 .

- The system is stable, since if $x[n]$ is bounded, $x[n^2]$ is also bounded.
- It is not causal. For example, $Tx[4] = x[16]$.
- It is linear. Let $y_1[n] = T(x_1[n]) = x_1[n^2]$, and $y_2[n] = T(x_2[n]) = x_2[n^2]$. Now

$$T(ax_1[n] + bx_2[n]) = ax_1[n^2] + bx_2[n^2] = ay_1[n] + by_2[n]$$

- It is not time-invariant. If $y[n] = T(x[n]) = x[n^2]$, then $T(x[n-1]) = x[n^2 - 1] \neq y[n-1]$.

(c) First notice that

$$\sum_{k=0}^{\infty} \delta[n-k] = u[n]$$

So $T(x[n]) = x[n]u[n]$. This transformation is therefore stable, causal, linear, but not time-invariant.

To see that it is not time invariant, notice that $T(\delta[n]) = \delta[n]$, but $T(\delta[n+1]) = 0$.

(d) $T(x[n]) = \sum_{k=n-1}^{\infty} x[k]$

- This is not stable. For example, $T(u[n]) = \infty$ for all $n \geq 1$.
- It is not causal, since it sums *forward* in time.
- It is linear, since

$$\sum_{k=n-1}^{\infty} ax_1[k] + bx_2[k] = a \sum_{k=n-1}^{\infty} x_1[k] + b \sum_{k=n-1}^{\infty} x_2[k]$$

- It is time-invariant. Let

$$y[n] = T(x[n]) = \sum_{k=n-1}^{\infty} x[k],$$

then

$$T(x[n-n_0]) = \sum_{k=n-n_0-1}^{\infty} x[k] = y[n-n_0]$$