

Solutions to Chapter 2 Exercises

2.1. From Eq. (2.4),

$$f(E_f - \Delta E) = \frac{1}{1 + e^{-\Delta E/kT}} = \frac{e^{\Delta E/kT}}{e^{\Delta E/kT} + 1},$$

and

$$f(E_f + \Delta E) = \frac{1}{1 + e^{\Delta E/kT}}.$$

Adding the above two equations yields

$$f(E_f - \Delta E) + f(E_f + \Delta E) = \frac{e^{\Delta E/kT} + 1}{e^{\Delta E/kT} + 1} = 1.$$

2.2. Neglecting the hole (last) term in Eq. (2.19), one obtains

$$N_c e^{-(E_c - E_f)/kT} + 2N_c e^{-(E_c + E_d - 2E_f)/kT} = N_d.$$

Treating $\exp(E_f/kT)$ as an unknown, the above equation is a quadratic equation with the solution

$$e^{E_f/kT} = \frac{-1 + \sqrt{1 + 8(N_d / N_c) e^{(E_c - E_d)/kT}}}{4e^{-E_d/kT}}.$$

Here only the positive root has been kept. For shallow donors with low to moderate concentration at room temperature, $(N_d/N_c)\exp[(E_c - E_d)/kT] \ll 1$, and the last equation can be approximated by

$$e^{E_f/kT} = \frac{4(N_d / N_c) e^{(E_c - E_d)/kT}}{4e^{-E_d/kT}} = \frac{N_d}{N_c} e^{E_c/kT},$$

which is the same as Eq. (2.20). If we compare the above relation with Eq. (2.19), it is clear that in this case, $\exp[-(E_d - E_f)/kT] \ll 1$, and $N_d^+ \approx N_d$ or complete ionization.

If the condition for low to moderate concentration of shallow donors is not met, then $\exp[-(E_d - E_f)/kT]$ is no longer negligible compared with unity. That means $N_d^+ < N_d$ (Eq. (2.19)) or incomplete ionization (freeze-out). [Note that incomplete ionization never occurs for shallow impurities: arsenic, boron, phosphorus, and antimony at room temperature, even for doping concentrations higher than N_c or N_v . This is because in heavily doped silicon, the

impurity level broadens and the ionization energy decreases to zero, as discussed in Section 2.1.2.3.]

2.3. (a) Substituting Eqs. (2.5) and (2.3) into the expression for average kinetic energy, one obtains

$$\langle \text{K.E.} \rangle = \frac{\int_{E_c}^{\infty} (E - E_c)^{3/2} e^{-(E-E_f)/kT} dE}{\int_{E_c}^{\infty} (E - E_c)^{1/2} e^{-(E-E_f)/kT} dE}.$$

Applying integration by parts to the numerator yields

$$\langle \text{K.E.} \rangle = \frac{(3/2)kT \int_{E_c}^{\infty} (E - E_c)^{1/2} e^{-(E-E_f)/kT} dE}{\int_{E_c}^{\infty} (E - E_c)^{1/2} e^{-(E-E_f)/kT} dE} = \frac{3}{2}kT.$$

(b) For a degenerate semiconductor at 0 K, $f(E) = 1$ if $E < E_f$ and $f(E) = 0$ if $E > E_f$. Here $E_f > E_c$. Therefore,

$$\langle \text{K.E.} \rangle = \frac{\int_{E_c}^{E_f} (E - E_c)^{3/2} dE}{\int_{E_c}^{E_f} (E - E_c)^{1/2} dE} = \frac{3}{5}(E_f - E_c).$$

2.4. With the point charge Q at the center, construct a closed spherical surface S with radius r . By symmetry, the electric field at every point on S has the same magnitude and points outward perpendicular to the surface. Therefore,

$$\oiint_S \mathbf{E} \cdot d\mathbf{S} = 4\pi r^2 \mathbf{E},$$

where \mathbf{E} is the magnitude of the electric field on S . 3-D Gauss's law then gives

$$\mathbf{E} = \frac{Q}{4\pi\epsilon_{si}r^2},$$

which is Coulomb's law.

Since $\mathbf{E} = -dV/dr$, the electric potential at a point on the sphere is

$$V = \frac{Q}{4\pi\epsilon_{si}r},$$

if one defines the potential to be zero at infinity.

2.5. (a) Construct a cylindrical Gaussian surface perpendicular to the charge sheet as shown:

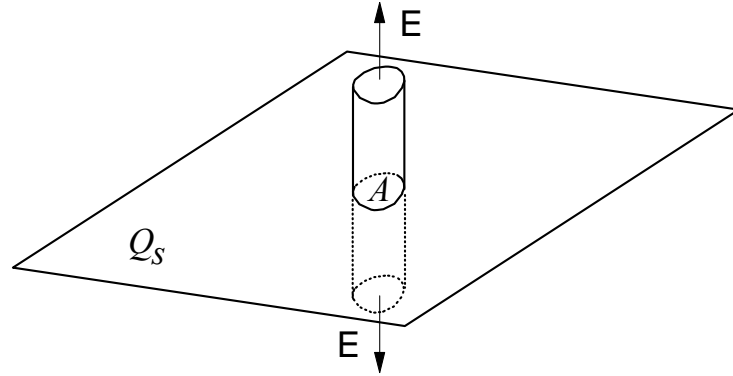

The cross-sectional area is A . At the two ends of the cylinder, the electric field \mathbf{E} is perpendicular to the surface and pointing outward. Along the side surface of the cylinder, the field is parallel to the surface, so $\mathbf{E} \cdot d\mathbf{S} = 0$. For an infinitely large sheet of charge, \mathbf{E} is uniform across A from symmetry. Therefore,

$$\oiint_S \mathbf{E} \cdot d\mathbf{S} = 2AE.$$

The charge enclosed within the surface is $Q_s A$. From Gauss's law, one obtains $E = Q_s/2\epsilon$.

(b) The field due to the positively charged sheet is $Q_s/2\epsilon$ pointing away from the sheet. The field due to the negatively charged sheet is also $Q_s/2\epsilon$, but pointing toward the negatively charged sheet. In the region between the two sheets, the two fields are in the same direction and the total field adds up to Q_s/ϵ , pointing from the positively charged sheet toward the negatively charged sheet. In the regions outside the two parallel sheets, the fields are equal and opposite to each other, resulting in zero net field.

2.6. (a) Using the integral expressions of Q_d and Q_i , one has

$$C_d \equiv -\frac{dQ_d}{d\psi_s} = \frac{qN_a(1 - e^{-q\psi_s/kT})}{E_s},$$

and

$$C_i \equiv -\frac{dQ_i}{d\psi_s} = \frac{q(n_i^2 / N_a)(e^{q\psi_s/kT} - 1)}{E_s}.$$

Here $E_s = E$ ($\psi = \psi_s$).

(b) Take the square of Eq. (2.182) and differentiate with respect to ψ_s , one obtains

$$2Q_s \frac{dQ_s}{d\psi_s} = 2\epsilon_{si} q N_a \left[\left(1 - e^{-q\psi_s/kT}\right) + \frac{n_i^2}{N_a^2} \left(e^{q\psi_s/kT} - 1\right) \right].$$

Using $Q_s = -\epsilon_{si} E_s$ (Gauss's law) and the above two equations in (a), it is straightforward to show that

$$C_{si} \equiv -\frac{dQ_s}{d\psi_s} = \frac{qN_a}{E_s} \left[\left(1 - e^{-q\psi_s/kT}\right) + \frac{n_i^2}{N_a^2} \left(e^{q\psi_s/kT} - 1\right) \right] = C_d + C_i.$$

(c) When $\psi_s = 2\psi_B$, $\exp(q\psi_s/kT) = (N_a/n_i)^2 \gg 1$ and $\exp(-q\psi_s/kT) \ll 1$. From (a), one has

$$C_i \cong C_d \cong \frac{qN_a}{E_s}.$$

(d) It is clear from Fig. 2.33 that Q_s and therefore E_s takes off rapidly beyond strong inversion. This means that $C_d \propto E_s^{-1}$ decreases rapidly beyond strong inversion. We say that the depletion layer (charge) is "screened" by the inversion layer. Note that C_i , on the other hand, increases rapidly beyond strong inversion because of the $\exp(q\psi_s/kT)$ factor.

2.7. In strong inversion and near the surface, Eq. (2.191) can be approximated by

$$\frac{d\psi}{dx} = -\sqrt{\frac{2kTn_i^2}{\epsilon_{si}N_a}} e^{q\psi/2kT}.$$

The solution to the above differential equation is

$$e^{-q\psi/2kT} = e^{-q\psi_s/2kT} + \frac{n_i q x}{\sqrt{2\epsilon_{si} k T N_a}},$$

where $\psi_s = \psi(x=0)$ is the surface potential.

Using Eq. (2.178) and the above solution, one has

$$n(x) = \frac{n_i^2}{N_a} e^{q\psi/kT} = \frac{n(0)}{\left(1 + \sqrt{q^2 n(0) / 2\epsilon_{si} k T x}\right)^2},$$

where $n(0)$ equals $(n_i^2/N_a)\exp(q\psi_s/kT)$.

2.8. Substituting Eq. (2.189) into Eq. (2.195), one obtains