

Chapter 2 – Answer Key, Introduction to Chemical Engineering: Tools for Today and Tomorrow

Reading Question 2.1:

The purpose of the equipment and conditions used in a process is to convert the starting materials into the desired products.

Reading Question 2.2:

A continuous process operates without interruptions in the flows and reactions of the process. In contrast, a batch process consists of multiple steps which are initiated and concluded in sequence, one batch at a time.

Reading Question 2.3:

A steady-state process is one in which none of the process characteristics change with time. In other words, the conditions at any point in the process remain the same (constant with respect to time).

Reading Question 2.4:

A PFD shows more detail than a block diagram and typically includes a stream table. The PFD also includes symbols or icons which “look like” the actual equipment as opposed to the rectangular blocks used in the block diagram.

Chapter 2 – Answer Key, Introduction to Chemical Engineering: Tools for Today and Tomorrow

Reading Question 2.5:

Test tube → Tank

Lab Burner → Heat Exchanger

Reaction Vessel → Reactor

Distillation Apparatus → Distillation Column

Homework Problem 2.1:

- a. continuous and non steady-state.
- b. batch and non steady-state.
- c. continuous and steady-state.

Homework Problem 2.2:

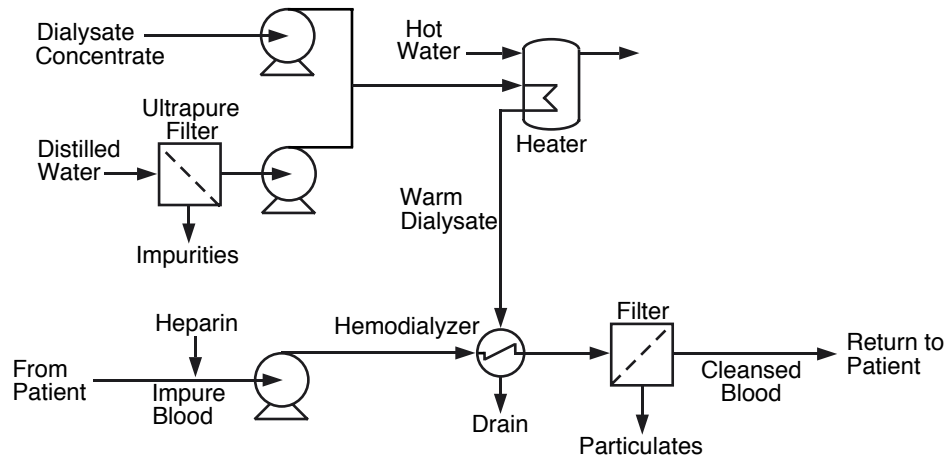

Homework Problem 2.3:

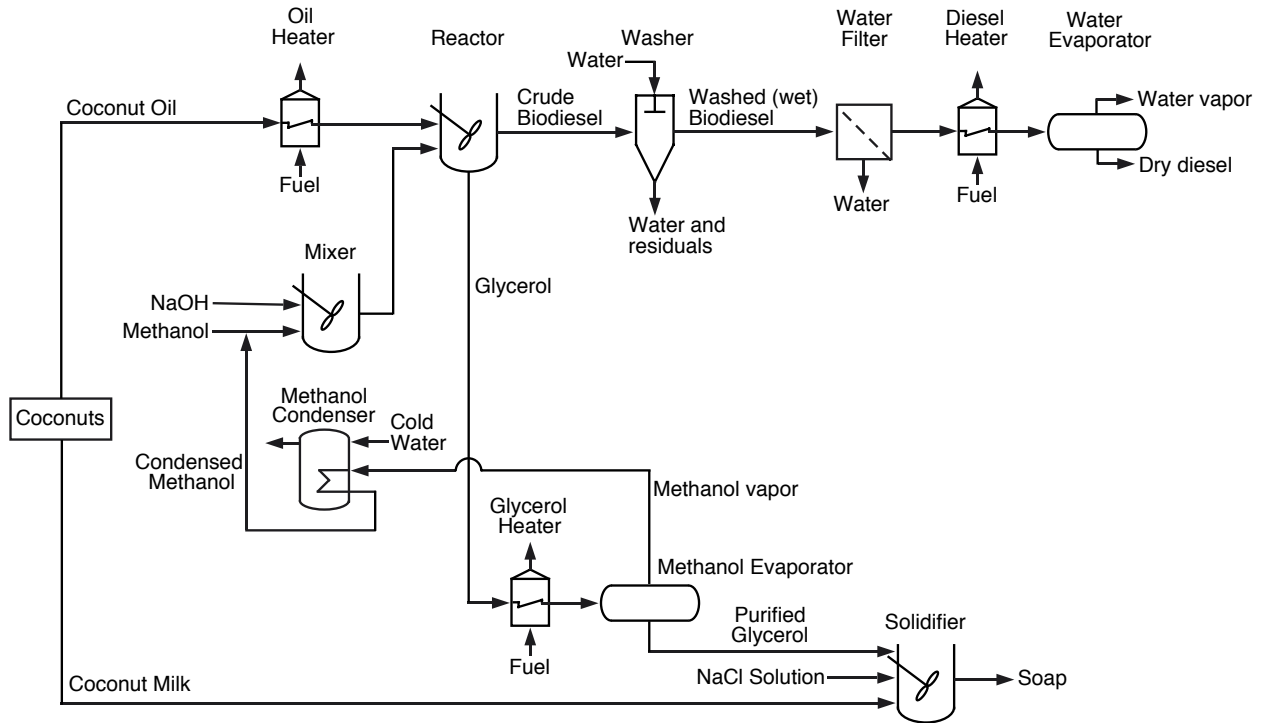

Homework Problem 2.4:

a. Block diagram

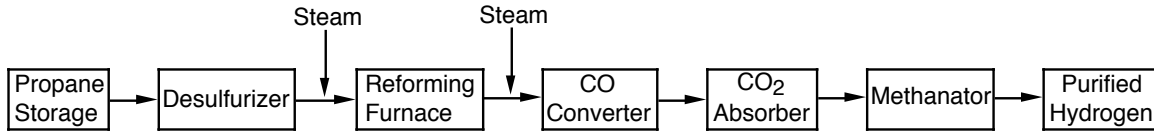

b. Process flow diagram

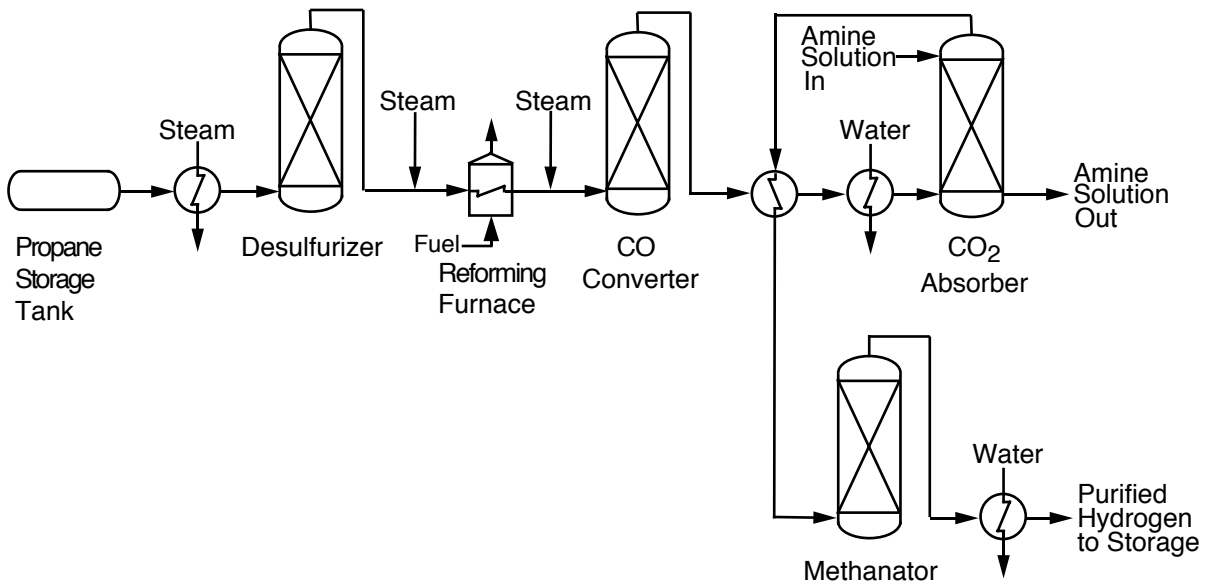

Homework Problem 2.5:

- a. fluid mechanics to bring the steam to the bones and flow the grease away
heat transfer from the steam to the grease to cause it to flow
- b. reaction engineering as the acid reacts with the solid material of the bones
fluid mechanics as the acid stream carries away the minerals
(mass transfer as the released minerals find their way into the acid stream)
- c. heat transfer as the steam heats the compartment
mass transfer as the water is removed from the gelatin

Fluid mechanics are also an important part of the entire operation because fluid flows from one unit to another unit in pipes.