

# CHAPTER 1: INTRODUCTION

## Short Answer Problems

- 1.1** True: The earth is taken to be non-accelerating for purposes of modeling systems on the surface of the earth.
- 1.2** False: Systems undergoing mechanical vibrations are not subject to nuclear reactions is an example of an implicit assumption.
- 1.3** True: Basic laws of nature can only be observed and postulated.
- 1.4** False: The point of application of surface forces is on the surface of the body.
- 1.5** False: The number of degree of freedom necessary to model a mechanical system is unique.
- 1.6** False: Distributed parameter systems are another name for continuous systems.
- 1.7** True: The Buckingham Pi theorem states that the number of dimensionless variables required in the formulation of a dimensional relationship is the number of dimensional variables, including the dependent variable, minus the number of dimensions involved in the dimensional variables.
- 1.8** True: The displacement of its mass center (x and y coordinates) and the rotation about an axis perpendicular to the mass center are degrees of freedom the motion of an unconstrained rigid body undergoing planar motion.
- 1.9** False: A particle traveling in a circular path has a velocity which is tangent to the circle.
- 1.10** False: The principle of work and energy is derived from Newton's second law by integrating the dot product of the law with a differential displacement vector as the particle moves from one location to another.
- 1.11** The continuum assumption treats all matter as a continuous material and implies that properties are continuous functions of the coordinates used in modeling the system.
- 1.12** An explicit assumption must be stated every time it is used, whereas an implicit assumption is taken for granted.
- 1.13** Constitutive equations are used to model the stress-strain relationships in materials. They are used in vibrations to model the force-displacement relationships in materials that behave as a spring.
- 1.14** A FBD is a diagram of a body abstracted from its surroundings and showing the effects of the surroundings as forces. They are drawn at an arbitrary time.

**1.15** The equation represents simple harmonic motion

**1.16** (a)  $X$  is the amplitude of motion; (b)  $\omega$  is the frequency at which the motion occurs  
(c)  $\phi$  is the phase between the motion and a pure sinusoid.

**1.17** The phase angle is positive for simply harmonic motion. Thus the response lags a pure sinusoid.

**1.18** A particle has mass that is concentrated at a point. A rigid body has a distribution of mass about the mass center.

**1.19** A rigid body undergoes planar motion if (1) the path of its mass center lies in a plane and (2) rotation occurs only about an axis perpendicular to the plane of motion of the mass center.

**1.20** The acceleration of a particle traveling in a circular path has a tangential component that is the radius of the circle times the angular acceleration of the particle and a centripetal acceleration which is directed toward the center of the circle which is the radius time the square of the angular velocity.

**1.21** An observer fixed at A observes, instantaneously that particle B is moving in a circular path of radius  $|\mathbf{r}_{B/A}|$  about A.

**1.22** It is applied to the FBD of the particle.

**1.23** The effective forces for a rigid body undergoing planar motion are a force applied at the mass center equal to  $m\bar{\mathbf{a}}$  and a moment equal to  $\bar{I}\alpha$ .

**1.24** The two terms of the kinetic energy of a rigid body undergoing planar motion are  $\frac{1}{2}m\bar{v}^2$ , the translational kinetic energy, and  $\frac{1}{2}\bar{I}\omega^2$ , the rotational kinetic energy.

**1.25** The principle of impulse and momentum states that a body's momentum (linear or angular) momentum at  $t_1$  plus the external impulses applied to the body (linear or angular) between  $t_1$  and  $t_2$  is equal to the system's momentum (linear or angular) at  $t_2$ .

**1.26** One, let  $\theta$  be the angular rotation of the bar, measured positive counterclockwise, from the system's equilibrium position.

**1.27** Four, let  $x_1$  be the absolute displacement of the cart,  $x_2$  the displacement of the leftmost block relative to the cart,  $x_3$  the displacement of the rightmost block away from the cart and  $\theta$  the counterclockwise angular rotation of the bar.

**1.28** Four, let  $x_1$  represent the displacement of the center of the disk to the right,  $x_2$  the downward displacement of the hanging mass,  $x_3$  the displacement of the sliding mass to the left and  $\theta$  the counterclockwise angular rotation of the rightmost pulley.

**1.29** Two, let  $\theta$  be clockwise the angular displacement of the bar and  $x$  the downward displacement of the hanging mass.

**1.30** Three, let  $x$  be the downward displacement of the middle of the upper bar,  $\theta$  its clockwise angular rotation and  $\phi$  the clockwise angular rotation of the lower bar.

**1.31** Three, let  $\theta$  represent the clockwise angular rotation of the leftmost disk,  $\phi$  the clockwise angular rotation of the rightmost disk and  $x$  the upward displacement of the leftmost hanging mass.

**1.32** Infinite, let  $x$  be a coordinate measured along the neutral axis of the beam measured for the fixed support. Then the displacement is a continuous function of  $x$  and  $t$ ,  $w(x,t)$ .

**1.33** Three, let  $x_1$  be the downward displacement of the hand,  $x_2$  the downward displacement of the palm and  $x_3$  the displacement of the fingers.

**1.34** Given: Uniform acceleration,  $a=2 \text{ m/s}^2$ . (a)  $v(t) = at + v_0 \Rightarrow v(5) = \left(2 \frac{\text{m}}{\text{s}^2}\right) (5 \text{ s}) + \left(0 \frac{\text{m}}{\text{s}}\right) = 10 \text{ m/s}$  (b)  $x(t) = a \frac{t^2}{2} + v_0 t + x_0 \Rightarrow x(5) = \frac{1}{2} \left(2 \frac{\text{m}}{\text{s}^2}\right) (5 \text{ s})^2 = 25 \text{ m}$

**1.35** Given:  $\mathbf{v} = 2 \cos 2t \mathbf{i} + 3 \sin 2t \mathbf{j} + 0.4 \mathbf{k} \text{ m/s}$ . (a)  $\mathbf{a} = \frac{d\mathbf{v}}{dt} = -4 \sin 2t \mathbf{i} + 6 \cos 2t \mathbf{j} \text{ m/s}^2 \Rightarrow a(\pi) = -4 \sin 2\pi \mathbf{i} + 6 \cos 2\pi \mathbf{j} \frac{\text{m}}{\text{s}^2} = 6 \mathbf{j} \text{ m/s}^2$  (b)  $\mathbf{r} = \int \mathbf{v} dt = \left[ (\sin 2t + C_1) \mathbf{i} + \left(-\frac{3}{2} \cos 2t + C_2\right) \mathbf{j} + (0.4t + C_3) \mathbf{k} \right] \text{ m}$ . The particle starts at the origin at  $t = 0$ . Application of this condition leads to)  $\mathbf{r}(t) = \left[ (\sin 2t) \mathbf{i} + \left(-\frac{3}{2} \cos 2t + \frac{3}{2}\right) \mathbf{j} + 0.4t \mathbf{k} \right] \text{ m}$ . Evaluation at  $\pi$  leads to  $\mathbf{r}(\pi) = \sin 2\pi \mathbf{i} + \left(-\frac{3}{2} \cos 2\pi + \frac{3}{2}\right) \mathbf{j} + 0.4\pi \mathbf{k} \text{ m} = 0.4\pi \mathbf{k} \text{ m}$ .

**1.36** Given:  $v=2 \text{ m/s}$ ,  $r=3 \text{ m}$ ,  $\theta(0) = 0$  (a)  $v = \frac{ds}{dt} \Rightarrow s = \int v dt = 2t$  at  $t=2 \text{ s}$  the particle has traveled 4 m. But  $s = r\theta$  thus  $\theta = \frac{4 \text{ m}}{3 \text{ m}} = 1.33 \text{ rad} = 76.2^\circ$ . (b) The acceleration of a particle traveling on a circular path has two components. One is  $\frac{dv}{dt}$  which is tangent to the circle and is zero for this problem. The other component is  $\frac{v^2}{r} = \frac{(2 \text{ m/s})^2}{3 \text{ m}} = 1.33 \text{ m/s}^2$  directed toward the center of the circle from the position of the particle.

**1.37** Given:  $m=2 \text{ kg}$ ,  $\bar{I} = 0.5 \text{ kg} \cdot \text{m}^2$ ,  $\bar{\mathbf{a}} = (5\mathbf{i} + 3\mathbf{j}) \text{ m/s}^2$ ,  $\alpha = 10 \text{ rad/s}^2$ . Effective forces are  $m\bar{\mathbf{a}} = (2 \text{ kg}) \left[ (5\mathbf{i} + 3\mathbf{j}) \frac{\text{m}}{\text{s}^2} \right] = (10\mathbf{i} + 15\mathbf{j}) \frac{\text{m}}{\text{s}^2}$  applied at the mass center and a couple  $\bar{I}\alpha = (0.5 \text{ kg} \cdot \text{m}^2)(10 \text{ rad/s}^2) = 5 \text{ N} \cdot \text{m}$ .

**1.38** Given:  $m = 0.1 \text{ kg}$ ,  $\mathbf{v} = (9\mathbf{i} + 11\mathbf{j}) \text{ m/s}$ . The kinetic energy of the particle is  $T = \frac{1}{2} m |\mathbf{v}|^2 = \frac{1}{2} (0.1 \text{ kg}) (\sqrt{9^2 + 11^2} \text{ m/s})^2 = 0.711 \text{ J}$ .

Chapter 1: Introduction

**1.39** Given:  $m=3 \text{ kg}$ ,  $\bar{v} = (3\mathbf{i} + 4\mathbf{j}) \text{ m/s}$ ,  $d=0.2 \text{ m}$  The angular velocity is calculated from  $|\bar{v}| = d\omega \Rightarrow \omega = \frac{|\bar{v}|}{d} = \frac{5 \text{ m/s}}{0.2 \text{ m}} = 20 \text{ rad/s}$ .

**1.40** Given:  $E = 100 \text{ J}$ ,  $I = 0.03 \text{ kg} \cdot \text{m}^2$  The kinetic energy of a rigid body which rotates about its centroidal axis is  $T = \frac{1}{2}I\omega^2$ . Thus  $100 \text{ J} = \frac{1}{2}(0.03 \text{ kg} \cdot \text{m}^2)\omega^2$  which leads to  $\omega = 81.65 \frac{\text{rad}}{\text{sec}}$ .

**1.41** Given:  $m = 5 \text{ kg}$ ,  $\bar{v} = 4 \text{ m/s}$ ,  $\omega = 20 \text{ rad/s}$ ,  $\bar{I} = 0.08 \text{ kg} \cdot \text{m}^2$ . The kinetic energy of a rigid body undergoing planar motion is  $T = \frac{1}{2}m\bar{v}^2 + \frac{1}{2}\bar{I}\omega^2 = \frac{1}{2}(5 \text{ kg})(4 \text{ m/s})^2 + \frac{1}{2}(0.08 \text{ kg} \cdot \text{m}^2)(20 \text{ rad/s})^2 = 56 \text{ J}$ .

**1.42** Given:  $F=12,000 \text{ N}$ ,  $\Delta t = 0.03 \text{ s}$ . The impulse applied to the system is  $I = F\Delta t = (12,000 \text{ N})(0.03 \text{ s}) = 360 \text{ N} \cdot \text{s}$ .

**1.43** Given:  $m = 3 \text{ kg}$ ,  $v_1 = 0 \text{ m/s}$ , force as given in Figure (a) The impulse imparted to the particle is  $I = \int_0^3 F dt = \frac{1}{2}(1)(100) + 2(100) + \frac{1}{2}(1)(100) = 300 \text{ N} \cdot \text{s}$  (b) The velocity at  $t=2 \text{ s}$  is given by the principle of impulse and momentum  $mv = \int_0^2 F dt \Rightarrow v = \frac{\int_0^2 F dt}{m} = \frac{250 \text{ N}\cdot\text{s}}{3 \text{ kg}} = 83.3 \text{ m/s}$ . (c) The velocity after  $5 \text{ s}$  is  $v = \frac{\int_0^5 F dt}{m} = \frac{300 \text{ N}\cdot\text{s}}{3 \text{ kg}} = 100 \text{ m/s}$ .

**1.44** Given:  $m = 2 \text{ kg}$ ,  $F=6 \text{ N}$ ,  $t=10 \text{ s}$ ,  $v_1 = 4 \text{ m/s}$ . The principle of work and energy is used to calculate how far the particle travels  $T_1 + U_{1 \rightarrow 2} = T_2$  after the velocity  $v_2$  is calculated from the principle of impulse and momentum  $mv_1 + I = mv_2 \Rightarrow v_2 = \frac{mv_1 + I}{m} = \frac{(2 \text{ kg})(4 \text{ m/s}) + (6 \text{ N})(10 \text{ s})}{2 \text{ kg}} = 34 \text{ m/s}$ . Then letting  $x$  be the distance traveled application of work and energy gives  $\frac{1}{2}(2 \text{ kg})(4 \text{ m/s})^2 + (6 \text{ N})x = \frac{1}{2}(2 \text{ kg})(34 \text{ m/s})^2$  which is solved to yield  $x=190 \text{ m}$ .

**1.45** (a) -(ii) (b)-(iv) (c)-(i) (d)-(v) (e)-(i) (f)-(v) (g)-(vi) (h)-(iii) (i)-(ix)

## Chapter Problems

1.1 The one-dimensional displacement of a particle is

$$x(t) = 0.5e^{-0.2t} \sin 5t \text{ m}$$

(a) What is the maximum displacement of the particle? (b) What is the maximum velocity of the particle? (c) What is the maximum acceleration of the particle?

Given:  $x(t)$

Find: (a)  $x_{max}$  (b)  $v_{max}$  (c)  $a_{max}$

Solution: (a) The maximum displacement occurs when the velocity is zero. Thus

$$\dot{x}(t) = 0.5e^{-0.2t}(-0.2 \sin 5t + 5 \cos 5t)$$

Setting the velocity to zero leads to

$$-0.2 \sin 5t + 5 \cos 5t = 0$$

or  $\tan 5t = 25$ . The first time that the solution is zero is  $t=0.3062$ . Substituting this value of  $t$  into the expression for  $x(t)$  leads to

$$x_{max} = 0.4699 \text{ m}$$

(b) The maximum velocity occurs when the acceleration is zero

$$\begin{aligned} \ddot{x}(t) &= 0.5e^{-0.2t}[-0.2(-0.2 \sin 5t + 5 \cos 5t) - \cos 5t - 25 \sin 5t] \\ &= 0.5e^{-0.2t}(-24.96 \sin 5t - 6 \cos 5t) \end{aligned}$$

The acceleration is zero when  $24.96 \sin 5t - 6 \cos 5t = 0 \Rightarrow \tan 5t = -0.240$ . The first time that this is zero is  $t=0.5812$  which leads to a velocity of

$$v_{min} = -2.185 \text{ m/s}$$

(c) The maximum acceleration occurs when  $\ddot{x} = 0$ ,

$$\begin{aligned} \ddot{x} &= 0.5e^{-0.2t}[-0.2(-24.96 \sin 5t - 6 \cos 5t) - (24.96)(5) \cos 5t + 30 \sin 5t] \\ &= 0.5e^{-0.2t}(34.992 \sin 5t - 123.6 \cos 5t) \end{aligned}$$

The maximum acceleration occurs when  $34.992 \sin 5t - 123.6 \cos 5t = 0 \Rightarrow \tan 5t = 3.53$ . The time at which the maximum acceleration occurs is  $t=0.2589$  s which leads to

$$a_{max} = -12.18 \text{ m/s}^2$$

Problem 1.1 illustrates the relationships between displacement, velocity and acceleration.

## Chapter 1: Introduction

### 1.2 The one-dimensional displacement of a particle is

$$x(t) = 0.5 e^{-0.2t} \sin(5t + 0.24) \text{ m} \quad (1)$$

(a) What is the maximum displacement of the particle? (b) What is the maximum velocity of the particle? (c) What is the maximum acceleration of the particle?

Given:  $x(t)$

Find: (a)  $x_{max}$  (b)  $v_{max}$  (c)  $a_{max}$

Solution: (a) The maximum displacement occurs when the velocity is zero. Thus

$$\dot{x}(t) = 0.5 e^{-0.2t} [-0.2 \sin(5t + 0.24) + 5 \cos(5t + 0.24)]$$

Setting the velocity to zero leads to

$$-0.2 \sin(5t + 0.24) + 5 \cos(5t + 0.24) = 0$$

or  $\tan(5t + 0.24) = 0.2582$ . The first time that the solution is zero is  $t=0.3062$ . Substituting this value of  $t$  into the expression for  $x(t)$  leads to

$$x_{max} = 0.4745 \text{ m}$$

(b) The maximum velocity occurs when the acceleration is zero

$$\begin{aligned} \ddot{x}(t) &= 0.5 e^{-0.2t} \{-0.2[(-0.2 \sin(5t + 0.24) + 5 \cos(5t + 0.24))] \\ &\quad - \cos(5t + 0.24) - 25 \sin(5t + 0.24)\} \\ &= 0.5 e^{-0.2t} [-24.96 \sin(5t + 0.24) - 6 \cos(5t + 0.24)] \end{aligned}$$

The acceleration is zero when

$$-24.96 \sin(5t + 0.24) - 6 \cos(5t + 0.24) = 0 \Rightarrow \tan(5t + 0.24) = -0.240.$$

The first time that this is zero is  $t = 0.5332$  which leads to a velocity of

$$v_{min} = -2.0188 \text{ m/s}$$

(c) The maximum acceleration occurs when  $\ddot{x} = 0$ ,

$$\begin{aligned} \ddot{x} &= 0.5 e^{-0.2t} \{-0.2[-24.96 \sin(5t + 0.24) - 6 \cos(5t + 0.24)] \\ &\quad - (24.96)(5) \cos(5t + 0.24) + 30 \sin(5t + 0.24)\} \\ &= 0.5 e^{-0.2t} [34.992 \sin(5t + 0.24) - 123.6 \cos(5t + 0.24)] \end{aligned}$$

The maximum acceleration occurs when

$$34.992 \sin(5t + 0.24) - 123.6 \cos(5t + 0.24) = 0 \Rightarrow \tan(5t + 0.24) = 3.53.$$

The time at which the maximum acceleration occurs is  $t=0.2109$  s which leads to

$$a_{max} = -12.30 \text{ m/s}^2$$

Problem 1.2 illustrates the relationships between displacement, velocity and acceleration.

**1.3** At the instant shown in Figure P1.3, the slender rod has a clockwise angular velocity of 5 rad/sec and a counterclockwise angular acceleration of 14 rad/sec<sup>2</sup>. At the instant shown, determine (a) the velocity of point  $P$  and (b) the acceleration of point  $P$ .

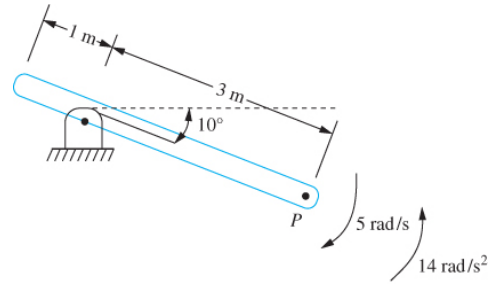

FIGURE P1.3

Given:  $\omega = 5 \text{ rad/sec}$ ,  $\alpha = 14 \text{ rad/sec}^2$ ,  $\theta = 10^\circ$

Find:  $v_p$ ,  $a_p$

Solution: The particle at the pin support, call it  $O$ , is fixed. Hence its velocity and acceleration are zero. Using the relative velocity and acceleration equations between two particles on a rigid body

$$\begin{aligned} \mathbf{v}_P &= \mathbf{v}_O + \boldsymbol{\omega} \times \mathbf{r}_{P/O} = -5\mathbf{k} \times (3 \cos 10^\circ \mathbf{i} - 3 \sin 10^\circ \mathbf{j}) = -15 \sin 10^\circ \mathbf{i} - 15 \cos 10^\circ \mathbf{j} \\ &= -2.604 \mathbf{i} - 14.772 \mathbf{j} \end{aligned}$$

and

$$\mathbf{a}_P = \mathbf{a}_O + \boldsymbol{\omega} \times (\boldsymbol{\omega} \times \mathbf{r}_{P/O}) + \boldsymbol{\alpha} \times \mathbf{r}_{P/O}$$

$$\mathbf{a}_P = (-66.5\mathbf{i} + 54.3\mathbf{j}) \frac{\text{m}}{\text{s}^2}$$

$$|\mathbf{a}_P| = 85.9 \frac{\text{m}}{\text{s}^2}$$

Alternate solution: The bar is rotating about a fixed point. Thus any point on the bar moves on a circular arc about the point of support. The particle  $P$  has two components of acceleration, one directed between  $P$  and  $O$  (the normal acceleration), and one tangent to the path of  $P$  whose direction is determined using the right hand rule (the tangential component).

The component normal to the path of  $P$  is

$$a_n = 3\text{m} \left( 5 \frac{\text{rad}}{\text{s}} \right)^2 = 75 \frac{\text{m}}{\text{s}^2}$$

and is directed between  $P$  and  $O$ . The tangential acceleration is

$$a_t = (3\text{m}) \left( 14 \frac{\text{rad}}{\text{s}^2} \right) = 42 \frac{\text{m}}{\text{s}^2}$$

The normal and tangential components of acceleration are illustrated on the diagram below.

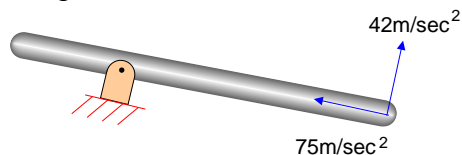

## Chapter 1: Introduction

Problem 1.3 illustrates the use of the relative acceleration equation of rigid body kinetics.

**1.4** At  $t = 0$ , a particle of mass 1.2 kg is traveling with a speed of 10 m/s that is increasing at a rate of  $0.5 \text{ m/s}^2$ . The local radius of curvature at this instant is 50 m. After the particle travels 100 m, the radius of curvature of the particle's path is 50 m.

- (a) What is the speed of the particle after it travels 100 m?
- (b) What is the magnitude of the particle's acceleration after it travels 100 m?
- (c) How long does it take the particle to travel 100 m?
- (d) What is the external force acting on the particle after it travels 100 m?

Given:  $m = 1.2 \text{ kg}$ ,  $v(t=0) = 10 \text{ m/s}$ ,  $dv/dt = 0.5 \text{ m/s}^2$ , and  $r = 25 \text{ m}$  when  $s = 100 \text{ m}$

Find: (a)  $v$  when  $s = 100 \text{ m}$ , (b)  $a$  when  $s = 3 \text{ m}$ , (c)  $t$  when  $s = 3 \text{ m}$

Solution: Let  $s(t)$  be the displacement of the particle, measured from  $t = 0$ . The particle's velocity is

$$v(t) = \int_0^t \frac{dv}{dt} dt + v(0) = \int_0^t 0.5 dt = 0.5t + 10$$

By definition  $v = ds/dt$ . Thus the displacement of the particle is obtained as

$$s(t) = \int_0^t v dt + s(0) = \int_0^t (0.5t + 10) dt = 0.25t^2 + 10t$$

When  $s = 100 \text{ m}$ ,

$$100 \text{ m} = 0.25t^2 + 10t \Rightarrow t = 8.28 \text{ s}$$

- (a) The velocity when  $s = 100 \text{ m}$  is

$$v = 0.5(8.28) + 10 = 14.14 \text{ m/s}$$

- (b) Since the particle is traveling along a curved path, its acceleration has two components: a tangential component equal to the rate of change of the velocity

$$a_t = \frac{dv}{dt} = 0.5 \text{ m/s}^2$$

and a normal component directed toward the center of curvature

$$a_n = \frac{v^2}{r} = \frac{(14.14 \text{ m/s})^2}{50 \text{ m}} = 4.00 \text{ m/s}^2$$

The magnitude of the acceleration at this instant is

$$|a| = \sqrt{a_t^2 + a_n^2} = \sqrt{(0.5 \text{ m/s}^2)^2 + (4.00 \text{ m/s}^2)^2}$$

$$|a| = 4.03 \text{ m/s}^2$$

- (c) The time for the particle to travel 100 m is previously calculated as  $t = 8.28 \text{ s}$   
 (d) The external force equation written in terms of magnitudes is

$$\sum |\mathbf{F}| = m|a|$$

which upon application to the particle gives

$$\sum |\mathbf{F}| = (1.2 \text{ kg}) \left( 4.03 \frac{\text{m}}{\text{s}^2} \right) = 4.84 \text{ N}$$

Problem 1.4 illustrates the kinematics of a particle traveling along a curved path.

**1.5** The machine of Figure P1.15 has a vertical displacement,  $x(t)$ . The machine has component which rotates with a constant angular speed,  $\omega$ . The center of mass of the rotating component is a distance  $e$  from its axis of rotation. The center of mass of the rotating component is as shown at  $t = 0$ . Determine the vertical component of the acceleration of the rotating component.

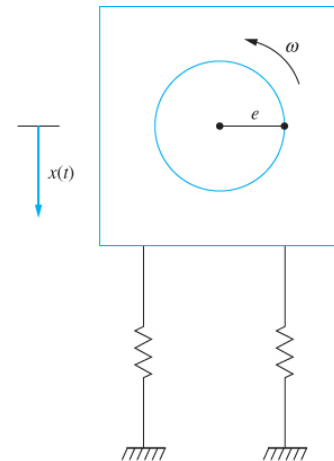

FIGURE P1.5

Given:  $e, \omega, x(t)$

Find:  $a_y$

Solution: The particle of interest is on a component that moves relative to the machine. From the relative acceleration equation,

$$\mathbf{a}_G = \mathbf{a}_M + \mathbf{a}_{G/M}$$

where

$$\mathbf{a}_M = -\ddot{x}(t)\mathbf{j}$$

and

$$\mathbf{a}_{G/M} = e\omega^2(-\cos\theta\mathbf{i} - \sin\theta\mathbf{j})$$

Since the angular velocity of the rotating component is constant and  $\theta = 0$  when  $t = 0$ ,

$$\theta = \omega t$$

Hence the vertical acceleration of the center of mass of the rotating component is

$$a_y = -\ddot{x}(t) - e\omega^2 \sin \omega t$$

Problem 1.5 illustrates application of the relative acceleration equation. Vibrations of machines subject to a rotating unbalance are considered in Chapter 4.

**1.6** The rotor of Figure P1.6 consists of a disk mounted on a shaft. Unfortunately, the disk is unbalanced, and the center of mass is a distance  $e$  from the center of the shaft. As the disk rotates, this causes a phenomena called “whirl”, where the disk bows. Let  $r$  be the instantaneous distance from the center of the shaft to the original axis of the shaft and  $\theta$  be the angle made by a given radius with the horizontal. Determine the acceleration of the mass center of the disk.

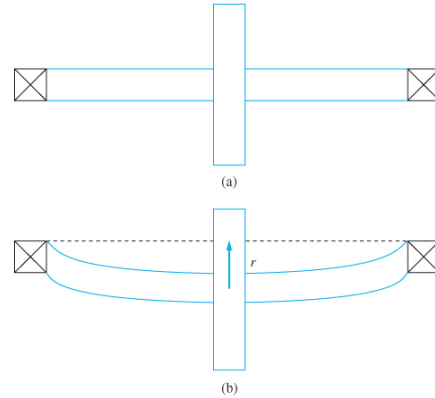

FIGURE P1.6

Given:  $e, r$

Find:  $\bar{\mathbf{a}}$

Solution: The position vector from the origin to the center of the disk is  $r\mathbf{i}_r$ , where  $r$  varies with time. The mass center moves in a circular path about the center of the disk. The relative acceleration equation gives

$$\mathbf{a}_c = \mathbf{a}_o + \boldsymbol{\alpha} \times r\mathbf{i}_r + \boldsymbol{\omega} \times (\boldsymbol{\omega} \times r\mathbf{i}_r) + \ddot{r}\mathbf{i}_r + 2\boldsymbol{\omega} \times \dot{r}\mathbf{i}_r$$

$$\mathbf{a}_c = (\ddot{r} - r\dot{\theta}^2)\mathbf{i}_r + (r\ddot{\theta} + 2\dot{r}\dot{\theta})\mathbf{i}_\theta$$

The acceleration of the mass center is then

$$\bar{\mathbf{a}} = (\ddot{r} - r\dot{\theta}^2)\mathbf{i}_r + (r\ddot{\theta} + 2\dot{r}\dot{\theta})\mathbf{i}_\theta - e\omega^2[\cos(\omega t - \theta)\mathbf{i}_r + \sin(\omega t - \theta)\mathbf{i}_\theta]$$

Problem 1.6 illustrates application of the relative acceleration equation.

**1.7** A 2 ton truck is traveling down an icy,  $10^\circ$  hill at 50 mph when the driver sees a car stalled at the bottom of the hill 250 ft away. As soon as he sees the stalled car, the driver applies his brakes, but due to the icy conditions, a braking force of only 2000 N is generated. Does the truck stop before hitting the car?

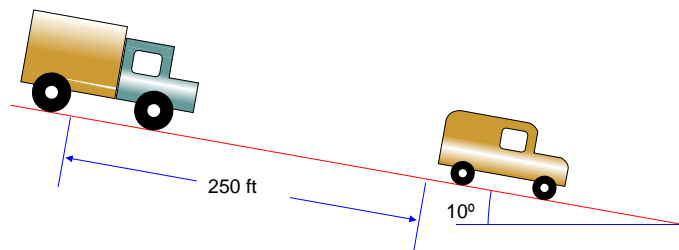

Given:  $W = 4000 \text{ lb.}, \theta = 10^\circ, d = 250 \text{ ft.}, F_b = 2000 \text{ N} = 449.6 \text{ lb.}, v_o = 50 \text{ mph} = 73.33 \text{ ft/sec}$

Find:  $v = 0$  before  $x = 250$  ft.

Solution: Application of Newton's Law to the free body diagram of the truck at an arbitrary instant

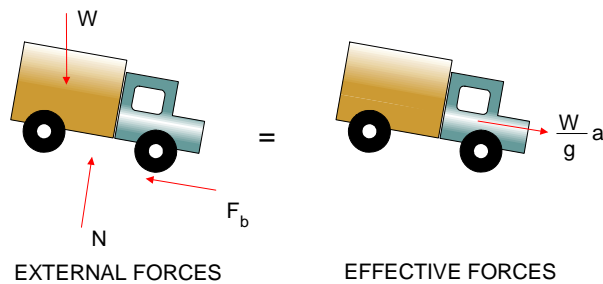

$$\begin{aligned} \left(\sum F_x\right)_{ext.} &= \left(\sum F_x\right)_{eff.} \\ -F_b + W \sin \theta &= \frac{W}{g} a \\ a &= g \left( -\frac{F_b}{W} + \sin \theta \right) \\ a &= 32.2 \frac{\text{ft}}{\text{sec}^2} \left( -\frac{449.6 \text{ lb}}{4000 \text{ lb}} + \sin 10^\circ \right) \\ a &= 1.973 \frac{\text{ft}}{\text{sec}^2} \end{aligned}$$

Since the acceleration is constant, the velocity and displacement of the truck are

$$\begin{aligned} v &= at + v_0 = 1.973t + 73.33 \\ x &= a \frac{t^2}{2} + v_0 t = 0.986t^2 + 73.33t \end{aligned}$$

The acceleration is positive thus the vehicle speeds up as it travels down the incline. The truck does not stop before hitting the car.

Problem 1.7 illustrates application of Newton's Law to a particle and kinematics of constant acceleration.

**1.8** The contour of a bumpy road is approximated by  $y(x) = 0.03 \sin(0.125x)$  m. What is the amplitude of the vertical acceleration of the wheels of an automobile as it travels over this road at a constant horizontal speed of 40 m/s?

## Chapter 1: Introduction

Given:  $y(x) = 0.03\sin(0.125x)$  m,  $v = 40$  m/s

Find: A

Solution: Since the vehicle is traveling at a constant horizontal speed its horizontal distance traveled in a time  $t$  is  $x = vt$ . Thus the vertical displacement of the vehicle is

$$y(t) = 0.03 \sin[0.125(40t)] = 0.03 \sin(5t) \text{ m}$$

The vertical velocity and acceleration of the vehicle are calculated as

$$v(t) = 0.03(5) \cos(5t) = 0.15 \cos(5t) \text{ m/s}$$

$$a(t) = -0.15(5) \sin(5t) = -0.75 \sin(5t) \text{ m/s}^2$$

Thus the amplitude of acceleration is  $A=0.75 \text{ m/s}^2$ .

Problem 1.8 illustrates the relationship between displacement, velocity, and acceleration for the motion of a particle.

**1.9** The helicopter of Figure P1.9 has a horizontal speed of 110 ft/s and a horizontal acceleration of  $3.1 \text{ ft/s}^2$ . The main blades rotate at a constant speed of 135 rpm. At the instant shown, determine the velocity and acceleration of particle  $A$ .

Given:  $v_h = 110 \text{ ft/s}$ ,  $a_h = 3 \text{ ft/s}^2$ ,  $\omega = 135 \text{ rpm} = 14.1 \text{ rad/s}$ ,  $r = 2.1 \text{ ft}$

Find:  $\mathbf{v}_A$ ,  $\mathbf{a}_A$

Solution: Construct a x-y coordinate system in the horizontal plane

As illustrated. Using this coordinate system

$$\mathbf{v} = -110\mathbf{i} \text{ ft/s}, \quad \mathbf{a} = -3\mathbf{i} \text{ ft/s}^2$$

The position vector of  $A$  relative to the helicopter at this instant is

$$\mathbf{r}_{A/h} = r[\cos(\pi/4)\mathbf{i} - \sin(\pi/4)\mathbf{j}] = 1.48\mathbf{i} - 1.48\mathbf{j}$$

The relative velocity equation is used to determine the velocity of particle  $A$  as

$$\mathbf{v}_A = \mathbf{v}_h + \omega\mathbf{k} \times \mathbf{r}_{A/h}$$

$$\mathbf{v}_A = -110\mathbf{i} + 14.1\mathbf{k} \times (1.48\mathbf{i} - 1.48\mathbf{j})$$

$$\mathbf{v}_A = -89.1\mathbf{i} + 20.9\mathbf{j} \text{ ft/s}$$

The relative acceleration equation is used to determine the acceleration of particle  $A$  as

$$\begin{aligned}\mathbf{a}_A &= \mathbf{a}_h + \boldsymbol{\alpha}\mathbf{k} \times \mathbf{r}_{A/h} + \boldsymbol{\omega}\mathbf{k} \times (\boldsymbol{\omega}\mathbf{k} \times \mathbf{r}_{A/h}) \\ \mathbf{a}_A &= -3.1\mathbf{i} + 14.1\mathbf{k} \times (20.87\mathbf{i} + 20.87\mathbf{j}) \\ \mathbf{a}_A &= -297.4\mathbf{i} + 294.6\mathbf{j} \text{ ft/s}^2\end{aligned}$$

Problem 1.9 illustrates the use of the relative velocity and relative acceleration equations.

**1.10** For the system shown in Figure P1.10, the angular displacement of the thin disk is given by  $\theta(t) = 0.03 \sin\left(30t + \frac{\pi}{4}\right)$  rad. The disk rolls without slipping on the surface. Determine the following as functions of time. (a) The acceleration of the center of the disk. (b) The acceleration of the point of contact between the disk and the surface. (c) The angular acceleration of the bar. (d) The vertical displacement of the block. (Hint: Assume small angular oscillations  $\phi$  of the bar. Then  $\sin \phi \approx \phi$ .)

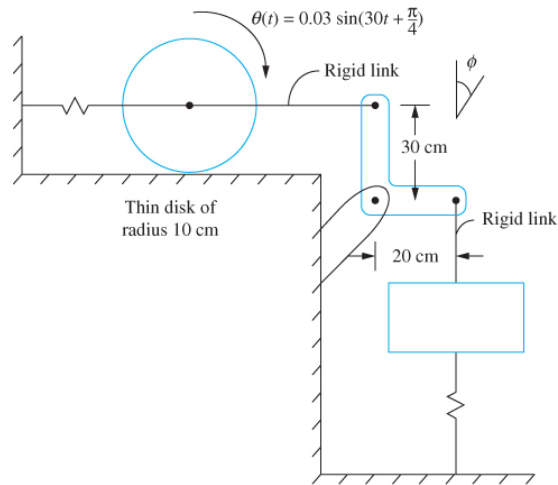

FIGURE P1.10

Given:  $\theta(t)$ ,  $r_d = 0.1$  m,  $\ell = 0.3$  m,  $d = 0.2$  m

Find: (a)  $\bar{a}_d$  (b)  $\bar{a}_c$  (c)  $\alpha$  (d)  $x$

Solution: (a) The angular acceleration of the disk is

$$\ddot{\theta}(t) = -(30)^2 0.03 \sin\left(30t + \frac{\pi}{4}\right) = -27 \sin\left(30t + \frac{\pi}{4}\right) \frac{\text{rad}}{\text{s}^2}$$

Since the disk rolls without slip the acceleration of the mass center is

$$a_d = r\alpha = (0.1 \text{ m}) \left(-27 \sin\left(30t + \frac{\pi}{4}\right) \frac{\text{rad}}{\text{s}^2}\right) = -2.7 \sin\left(30t + \frac{\pi}{4}\right) \frac{\text{m}}{\text{s}^2}$$

(b) Since the disk rolls without slip the horizontal acceleration of the point of contact is zero. The vertical acceleration is  $r\dot{\theta}^2$  towards the center

$$\mathbf{a}_c = (0.1 \text{ m}) \left[ (30)(0.03) \cos\left(30t + \frac{\pi}{4}\right) \frac{\text{rad}}{\text{s}} \right]^2 \mathbf{j}$$

$$= 0.081 \left[ \cos \left( 30t + \frac{\pi}{4} \right) \right]^2 \frac{\text{m}}{\text{s}^2} \mathbf{j}$$

(c) Assuming small  $\phi$  the angular displacement of the link is  $\ell\phi = x_d$  or

$$\ddot{\phi} = \frac{\ddot{x}}{\ell} = \frac{-2.7 \sin \left( 30t + \frac{\pi}{4} \right) \frac{\text{m}}{\text{s}^2}}{0.3 \text{ m}}$$

$$\ddot{\phi} = -9 \sin \left( 30t + \frac{\pi}{4} \right) \frac{\text{r}}{\text{s}^2}$$

(d) The displacement of the mass center of the block is  $x = d\phi$  or

$$x = (0.2) \frac{9}{(30)^2} \sin \left( 30t + \frac{\pi}{4} \right) = 2 \sin \left( 30t + \frac{\pi}{4} \right) \text{ mm}$$

Problem 1.10 illustrates angular acceleration and acceleration of a body rolling without slip.

**1.11** The velocity of the block of the system of Figure P1.11 is  $\dot{y} = 0.02 \sin 20t$  m/s downward. (a) What is the clockwise angular displacement of the pulley? (b) What is the displacement of the cart?

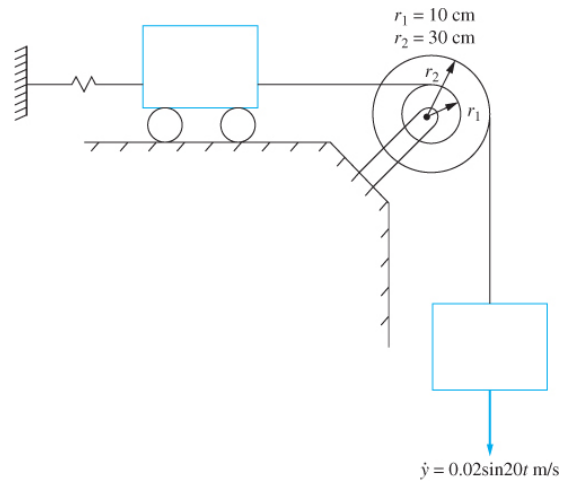

FIGURE P1.11

Given:  $\dot{y}$ ,  $r_1 = 0.1$  m,  $r_2 = 0.3$  m

Find: (a)  $\theta(t)$  (b)  $x(t)$

Solution: the displacement of the block is

$$y(t) = \int \dot{y} dt = 0.001(1 - \cos 20t) \text{ m}$$

(a) The angular displacement of the pulley is

$$\theta = \frac{y}{r_2} = \frac{0.001(1 - \cos 20t) \text{ m}}{0.3 \text{ m}} = 3.33 \times 10^{-4}(1 - \cos 20t) \text{ rad}$$

(b) The displacement of the cart is

$$x = \frac{r_1}{r_2} y = \frac{0.1 \text{ m}}{0.3 \text{ m}} [0.001(1 - \cos 20t) \text{ m}] = 3.33 \times 10^{-4}(1 - \cos 20t) \text{ m}$$

Problem 1.11 illustrates velocity and kinematics.

**1.12** A 60-lb block is connected by an inextensible cable through the pulley to the fixed surface, as shown in Figure P1.12. A 40-lb weight is attached to the pulley, which is free to move vertically. A force of magnitude  $P = 100(1 + e^{-t})$  lb tows the block. The system is released from rest at  $t = 0$ .

(a) What is the acceleration of the 60 lb block as a function of time?

(b) How far does the block travel up the incline before it reaches a velocity of 2 ft/sec?

Given:  $W_1 = 60$  lbs,  $W_2 = 40$  lbs,  $P = 100(1 + e^{-t})$  lb,  $\mu = 0.3$ ,  $\theta = 45^\circ$

Find:  $a(t)$ ,  $x(v = 2 \text{ ft/sec})$

Solution: Let  $x$  be the distance the block travels from  $t = 0$ . Let  $y$  be the vertical distance traveled by the pulley from  $t = 0$ . The total length of the cable connecting the block, the pulley and the surface is constant as the block moves up the incline. Thus, referring to the diagrams below. At  $t = 0$ ,  $\ell = a + b + c$ . At an arbitrary time,  $\ell = a + x + b - y + c - y = a + b + c + x - 2y$ . Hence  $y = x/2$ .

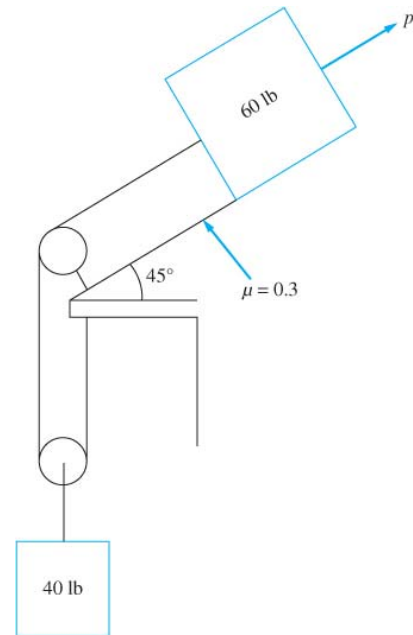
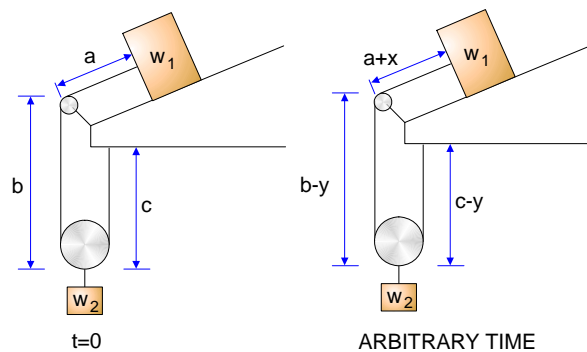
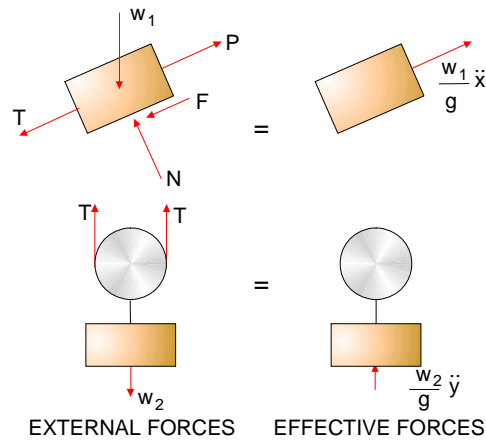

FIGURE P1.12



Free body diagrams of the blocks are shown at an arbitrary instant of time.

## Chapter 1: Introduction



From the free body diagrams of the pulley

$$\begin{aligned} (\sum F)_{ext.} &= (\sum F)_{eff.} \\ 2T - m_2 g &= m_2 \ddot{y} \\ T &= \frac{m_2}{2} (\ddot{y} + g) \end{aligned} \quad (1)$$

Summation of forces in the direction normal to the incline for the block yields

$$N = m_1 g \cos \theta \quad (2)$$

Summing forces in the direction along the incline on the block

$$\begin{aligned} (\sum F)_{ext.} &= (\sum F)_{eff.} \\ -T + P - F - m_1 g \sin \theta &= m_1 \ddot{x} \end{aligned} \quad (3)$$

Noting that  $F = \mu N$  and using eqs. (1) and (2) in eq. (3) gives

$$\ddot{x} = \frac{-\frac{m_2 g}{2} + P - \mu m_1 g \cos \theta - m_1 g \sin \theta}{m_1 + \frac{m_2}{4}} \quad (4)$$

Substituting given values leads to

$$\ddot{x} = 11.42 + 46.0e^{-t} \frac{\text{ft}}{\text{s}^2}$$

The velocity is calculated from

$$\int_0^v dv = \int_0^t (11.42 + 46.9e^{-t}) dt \quad (5)$$

$$v = 46.0 + 11.42t - 46.0e^{-t}$$

Setting  $v = 2\text{ft/sec}$  in eq. (5) and solving the resulting equation for  $t$  by trial and error reveals that it takes  $0.0354\text{ sec}$  for the velocity to reach  $2\text{ ft/sec}$ . The displacement from the initial position is calculated from

$$\int_0^x dx = \int_0^t (46.0 + 11.42t - 46.0e^{-t}) dt \quad (6)$$

$$x(t) = -46.0 + 46.0t + 5.71t^2 + 46.0e^{-t}$$

Setting  $t = 0.0354\text{ sec}$  in eq.(6), leads to

$$x = 0.0356\text{ ft}$$

Problem 1.12 illustrates the application of Newton's Law to a particle, the kinematics of pulley systems, and relationships between acceleration, velocity, and displacement. Note that the time required to attain a velocity of  $2\text{ ft/sec}$  could have been attained using impulse and momentum.

**1.13** Repeat Problem 1.12 for a force of  $P = 100t\text{ N}$ .

Given:  $W_1 = 60\text{ lbs}$ ,  $W_2 = 40\text{ lbs}$ ,  $P = 100t\text{ lbs}$ ,  $\mu = 0.3$ ,  $\theta = 45^\circ$

Find:  $a(t)$ ,  $x(v = 2\text{ ft/sec})$

Solution: Let  $x$  be the distance the block travels from  $t = 0$ . Let  $y$  be the vertical distance traveled by the pulley from  $t = 0$ . The total length of the cable connecting the block, the pulley and the surface is constant as the block moves up the incline. Thus, referring to the diagrams below. At  $t = 0$ ,  $\ell = a + b + c$ . At an arbitrary time,  $\ell = a + x + b - y + c - y = a + b + c + x - 2y$ . Hence  $y = x/2$ .

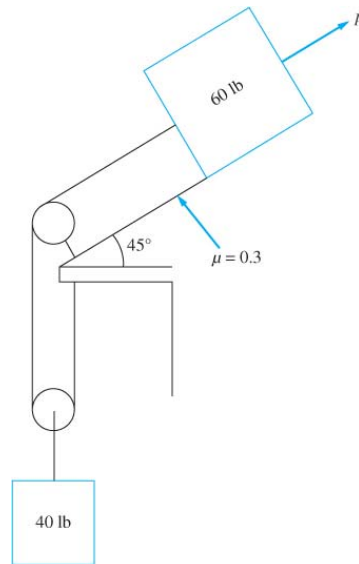
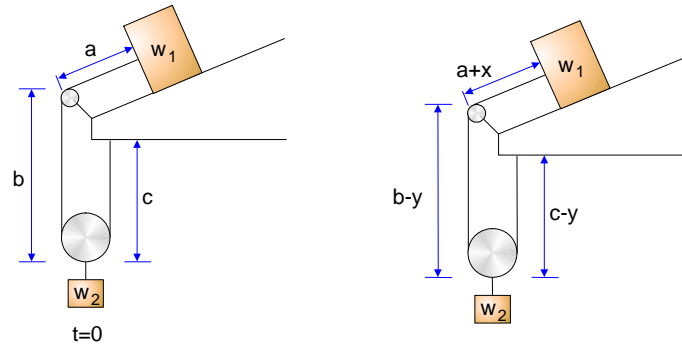
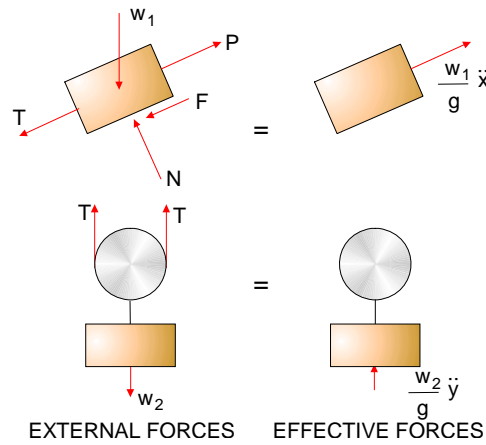

FIGURE P1.12

## Chapter 1: Introduction



Free body diagrams of the blocks are shown at an arbitrary instant of time.



From the free body diagrams of the pulley

$$\begin{aligned} (\sum F)_{ext.} &= (\sum F)_{eff.} \\ 2T - m_2 g &= m_2 \ddot{y} \\ T &= \frac{m_2}{2} (\ddot{y} + g) \end{aligned} \quad (1)$$

Summation of forces in the direction normal to the incline for the block yields

$$N = m_1 g \cos \theta \quad (2)$$

Summing forces in the direction along the incline on the block

$$\begin{aligned} (\sum F)_{ext.} &= (\sum F)_{eff.} \\ -T + P - F - m_1 g \sin \theta &= m_1 \ddot{x} \end{aligned} \quad (3)$$

Noting that  $F = \mu N$  and using eqs.(1) and (2) in eq.(3) gives

$$\ddot{x} = \frac{-\frac{m_2 g}{2} + P - \mu m_1 g \cos \theta - m_1 g \sin \theta}{m_1 + \frac{m_2}{4}} \quad (4)$$

Substituting given values leads to

$$\ddot{x} = 36.79t - 34.57$$

Note that the acceleration is initially negative, then becomes positive.

$$\int_0^v dv = \int_0^t (36.79t - 34.57) dt \quad (5)$$

$$v = 18.40t^2 - 34.57t$$

Setting  $v = 2$  ft/sec in eq.(5) and solving the resulting quadratic equation reveals that it takes 2.07 sec for the velocity to reach 2 ft/sec. The displacement from the initial position is calculated from

$$\int_0^x dx = \int_0^t (18.4t^2 - 34.57t) dt \quad (6)$$

$$x(t) = 6.13t^3 - 17.28t^2$$

$$x(2.07 \text{ sec}) = -19.76 \text{ ft}$$

Problem 1.13 illustrates the application of Newton's Law to a particle, the kinematics of pulley systems, and relationships between acceleration, velocity, and displacement. Note that the time required to attain a velocity of 2 ft/sec could have been attained using impulse and momentum.

**1.14** Figure P1.14 shows a schematic diagram of a one-cylinder reciprocating one-cylinder engine. If at the instant time shown the piston has a velocity  $v$  and an acceleration  $a$ , determine (a) the angular velocity of the crank and (b) the angular acceleration of the crank in terms of  $v$ ,  $a$ , the crank radius  $r$ , the connecting rod length  $\ell$ , and the crank angle  $\theta$ .

Given:  $r$ ,  $\ell$ ,  $\theta$ ,  $v$ ,  $a$

Find:  $\alpha_{AB}$

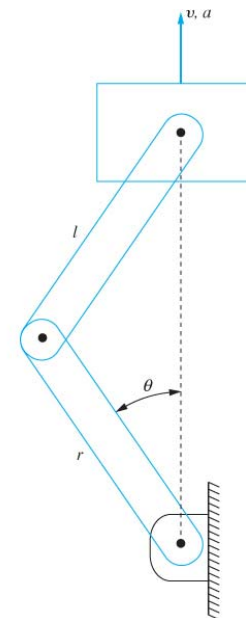
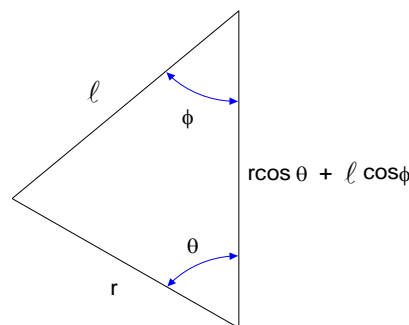

FIGURE P1.14

Chapter 1: Introduction

Solution: (a) From the law of sines

$$\frac{r}{\sin \phi} = \frac{\ell}{\sin \theta}$$

or

$$\sin \phi = \frac{r}{\ell} \sin \theta \quad (1)$$

Then from trigonometry

$$\begin{aligned} \cos \phi &= \sqrt{1 - \sin^2 \phi} \\ &= \sqrt{1 - \left(\frac{r}{\ell} \sin \theta\right)^2} \end{aligned} \quad (2)$$

Using the relative velocity equation,

$$\begin{aligned} \vec{v}_B &= \vec{v}_A + \vec{\omega}_{AB} \times \vec{r}_{B/A} \\ &= \omega_{AB} \vec{k} \times (-r \sin \theta \vec{i} + r \cos \theta \vec{j}) \\ &= -r \omega_{AB} \cos \theta \vec{i} - r \omega_{AB} \sin \theta \vec{j} \end{aligned}$$

and

$$\begin{aligned} \vec{v}_C &= \vec{v}_B + \vec{\omega}_{BC} \times \vec{r}_{C/B} \\ &= \vec{v}_B + \omega_{BC} \vec{k} \times (\ell \sin \phi \vec{i} + \ell \cos \phi \vec{j}) \\ &= (-r \omega_{AB} \sin \theta + \ell \omega_{BC} \sin \phi) \vec{j} - (r \omega_{AB} \cos \theta + \ell \omega_{BC} \cos \phi) \vec{i} \end{aligned}$$

The x component yields

$$\omega_{BC} = -\frac{r}{\ell} \omega_{AB} \frac{\cos \theta}{\cos \phi} \quad (3)$$

which when substituted into the y component leads to

$$\omega_{AB} = -\frac{v}{r(\sin \theta + \cos \theta \tan \phi)} \quad (4)$$

(b) The relative acceleration equations give

$$\begin{aligned}\vec{a}_B &= \vec{a}_A + \alpha_{AB} \times \vec{r}_{B/A} + \vec{\omega}_{AB} \times (\vec{\omega}_{AB} \times \vec{r}_{B/A}) \\ &= (-r\alpha_{AB} \cos \theta + r\omega_{AB}^2 \sin \theta) \vec{i} + (-r\alpha_{AB} \sin \theta - r\omega_{AB}^2 \cos \theta) \vec{j}\end{aligned}$$

and

$$\begin{aligned}\vec{a}_C &= \vec{a}_B + \alpha_{BC} \times \vec{r}_{C/B} + \vec{\omega}_{BC} \times (\vec{\omega}_{BC} \times \vec{r}_{C/B}) \\ &= (-r\alpha_{AB} \cos \theta - r\omega_{AB}^2 \sin \theta - \ell\alpha_{BC} \cos \phi - \ell\omega_{BC}^2 \sin \phi) \vec{i} \\ &\quad + (-r\alpha_{AB} \sin \theta + r\omega_{AB}^2 \cos \theta + \ell\alpha_{BC} \sin \phi - \ell\omega_{BC}^2 \cos \phi) \vec{j}\end{aligned}$$

The x component is used to determine

$$\alpha_{BC} = -\frac{1}{\ell \cos \phi} (r\omega_{AB}^2 \sin \theta + r\alpha_{AB} \cos \theta + \ell\omega_{BC}^2 \sin \phi)$$

Which when used in the y component leads to

$$\alpha_{AB} = -\frac{a - r\omega_{AB}^2 \cos \theta + \ell\omega_{BC}^2 \cos \phi - r\omega_{AB}^2 \sin \theta \tan \phi + \ell\omega_{BC}^2 \sin \phi \tan \phi}{r(\sin \theta + \cos \theta \tan \phi)} \quad (5)$$

Equation (5) is used to determine the angular acceleration of the crank using eqs.(1) - (4).

Problem 1.14 illustrates application of the relative velocity and relative acceleration equations for rigid body kinematics.

**1.15** Determine the reactions at A for the two-link mechanism of Figure P1.15. The roller at C rolls on a frictionless surface.

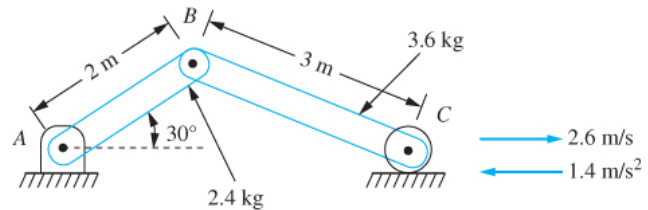

FIGURE P1.15

Given :  $\theta = 30^\circ$ ,  $L_{AB} = 2$  m,  $L_{BC} = 3$  m,  $m_{AB} = 2.4$  kg,  $m_{BC} = 3.6$  kg,  $v_C = 2.6$  m/sec,  $a_C = -1.4$  m/sec<sup>2</sup>

Find :  $A_x$ ,  $A_y$

Solution : From the law of sines

$$\begin{aligned}\frac{\sin \theta}{L_{BC}} &= \frac{\sin \phi}{L_{AB}} \\ \sin \phi &= \frac{L_{AB}}{L_{BC}} \sin \theta = 0.333\end{aligned}$$

From trigonometry

## Chapter 1: Introduction

$$\cos \phi = \sqrt{1 - \sin^2 \phi} = 0.943$$

The relative position vectors are

$$\vec{r}_{B/A} = L_{AB}(\cos \theta \vec{i} + \sin \theta \vec{j}) = 1.73 \vec{i} + \vec{j} \text{ m}$$

$$\vec{r}_{C/B} = L_{BC}(\cos \phi \vec{i} - \sin \phi \vec{j}) = 2.83 \vec{i} - \vec{j} \text{ m}$$

Using the relative velocity equation between two particles on a rigid body,

$$\mathbf{v}_B = \mathbf{v}_A + \omega_{AB} \mathbf{k} \times \mathbf{r}_{B/A}$$

$$\mathbf{v}_B = -\omega_{AB} \mathbf{i} + 1.73 \omega_{AB} \mathbf{j}$$

$$\mathbf{v}_C = \mathbf{v}_B + \omega_{BC} \mathbf{k} \times \mathbf{r}_{C/B}$$

$$2.6 \mathbf{i} = (-\omega_{AB} + \omega_{BC}) \mathbf{i} + (1.73 \omega_{AB} + 2.83 \omega_{BC}) \mathbf{j}$$

Equating like components from both sides leads to

$$1.73 \omega_{AB} + 2.83 \omega_{BC} = 0$$

$$-\omega_{AB} + \omega_{BC} = 2.6$$

Simultaneous solution of the above equations leads to

$$\omega_{AB} = -1.61 \frac{\text{rad}}{\text{s}}, \quad \omega_{BC} = 0.986 \frac{\text{rad}}{\text{s}}$$

Use of the relative acceleration equation between two particles on a rigid body,

$$\mathbf{a}_B = \mathbf{a}_A + \alpha_{AB} \mathbf{k} \times \mathbf{r}_{B/A} + \omega_{AB} \mathbf{k} \times (\omega_{AB} \mathbf{k} \times \mathbf{r}_{B/A})$$

$$\mathbf{a}_B = (-\alpha_{AB} - 4.48) \mathbf{i} + (1.73 \alpha_{AB} - 2.59) \mathbf{j} \frac{\text{m}}{\text{s}^2}$$

$$\mathbf{a}_C = \mathbf{a}_B + \alpha_{BC} \mathbf{k} \times \mathbf{r}_{C/B} + \omega_{BC} \mathbf{k} \times (\omega_{BC} \mathbf{k} \times \mathbf{r}_{C/B})$$

$$-1.4 \mathbf{i} = (-\alpha_{AB} + \alpha_{BC} + 7.23) \mathbf{i} + (1.72 \alpha_{AB} + 2.83 \alpha_{BC} - 1.62) \mathbf{j}$$

Equating like components from both sides leads to

$$1.72 \alpha_{AB} + 2.83 \alpha_{BC} = 1.62$$

$$-\alpha_{AB} + \alpha_{BC} = -8.63$$

Simultaneous solution of the above equations leads to

$$\alpha_{AB} = 5.72 \frac{\text{rad}}{\text{s}^2}, \quad \alpha_{BC} = -2.91 \frac{\text{rad}}{\text{s}^2}$$

The relative acceleration equations are used to calculate the accelerations of the mass centers of the links as

$$\mathbf{a}_{AB} = -5.09\mathbf{i} + 3.65\mathbf{j} \frac{\text{m}}{\text{s}^2}$$

$$\mathbf{a}_{BC} = -13.64\mathbf{i} + 3.66\mathbf{j} \frac{\text{m}}{\text{s}^2}$$

Free body diagrams of the two bar linkage at this instant of time are shown below

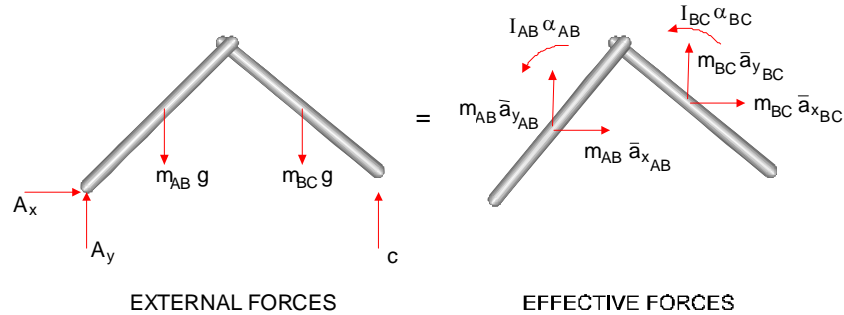

Summing moments about C

$$\begin{aligned} (\sum M_C)_{ext.} &= (\sum M_C)_{eff.} \\ A_y(L_{AB} \cos \theta + L_{BC} \cos \phi) - m_{AB}g \left( \frac{L_{AB}}{2} \cos \theta + L_{BC} \cos \phi \right) - m_{BC}g \frac{L_{BC}}{2} \cos \phi \\ &= -\bar{I}_{AB}\alpha_{AB} - \bar{I}_{BC}\alpha_{BC} + m_{AB}\bar{a}_{x_{AB}} \frac{L_{AB}}{2} \sin \theta + m_{BC}\bar{a}_{x_{BC}} \frac{L_{BC}}{2} \sin \phi \\ &\quad + m_{AB}\bar{a}_{y_{AB}} \left( \frac{L_{AB}}{2} \cos \theta + L_{BC} \cos \phi \right) + m_{BC}\bar{a}_{y_{BC}} \frac{L_{BC}}{2} \cos \phi \end{aligned}$$

Noting that

$$\bar{I}_{AB} = \frac{1}{12} m_{AB} L_{AB}^2 = 0.8 \text{ kg} \cdot \text{m}^2, \bar{I}_{BC} = \frac{1}{12} m_{BC} L_{BC}^2 = 2.7 \text{ kg} \cdot \text{m}^2$$

and substituting given and calculated values and solving for  $A_y$  leads to

$$A_y = 28.49 \text{ N}$$

Summing forces in the horizontal direction

$$\begin{aligned} (\sum F_x)_{ext.} &= (\sum F_x)_{eff.} \\ A_x &= m_{AB}\bar{a}_{x_{AB}} + m_{BC}\bar{a}_{x_{BC}} \end{aligned}$$

Substituting given and calculated values leads to

$$A_x = -61.32 \text{ N}$$

Problem 1.15 illustrates (a) application of the relative velocity equation for a linkage, (b) application of the relative acceleration equation for a linkage, and (c) application of Newton's laws to a system of rigid bodies. This problem is a good illustration of the effectiveness of the effective force method of application of Newton's Laws. Use of this method allows a free body diagram of the entire linkage to be drawn and used to solve for the unknown reactions. Application of Newton's Laws to a single rigid body exposes the reactions in the pin connection at B and complicates the solution.

**1.16** Determine the angular acceleration of each of the disks in Figure P1.16.

Given: Disk of  $I_p = 4 \text{ kg}\cdot\text{m}^2$ ,  $r = 60 \text{ cm}$  with  
 (a)  $m_1 = 30 \text{ kg}$  and  $m_2 = 20 \text{ kg}$  blocks attached or  
 (b)  $F_1 = 270 \text{ N}$  and  $F_2 = 180 \text{ N}$  forces attached.

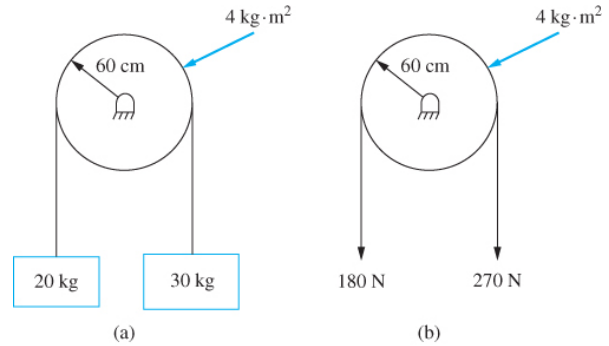
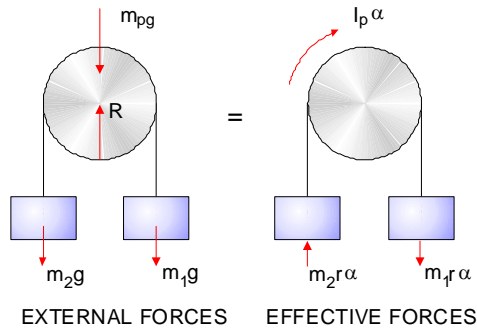

FIGURE P1.16

Find:  $\alpha$

Solution:

(a) Free body diagrams of the disk and the blocks are shown below



Summing moments about the center of the disk

$$\begin{aligned}
 (\sum M_O)_{ext.} &= (\sum M_O)_{eff.} \\
 m_1 g r - m_2 g r &= I_p \alpha + m_1 r^2 \alpha + m_2 r^2 \alpha \\
 \alpha &= \frac{(m_1 - m_2) g r}{I_p + (m_1 + m_2) r^2} = 2.68 \frac{\text{rad}}{\text{s}^2}
 \end{aligned}$$

(b) Free body diagrams of the disk are shown below

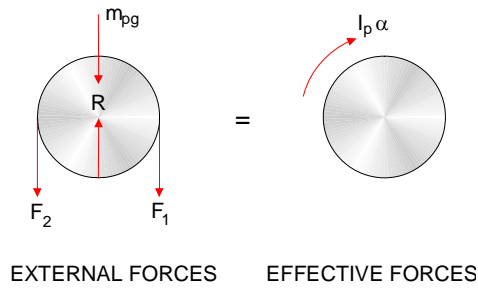

Summing moments about the center of the disk

$$\begin{aligned}
 (\sum M_o)_{ext.} &= (\sum M_o)_{eff.} \\
 F_1 r - F_2 r &= I_p \alpha \\
 \alpha &= \frac{(F_1 - F_2)r}{I_p} = 13.5 \frac{\text{rad}}{\text{s}^2}
 \end{aligned}$$

Problem 1.16 illustrates application of Newton's Laws to systems of rigid bodies. It also illustrates the difference between an applied force and a mass.

**1.17** Determine the reactions at the pin support and the applied moment if the bar of Figure P1.17 has a mass of 50 g.

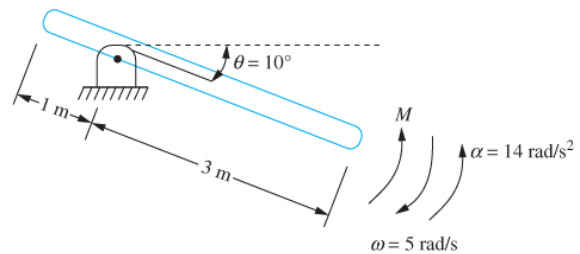

FIGURE P1.17

Given:  $\alpha = 14 \text{ rad/sec}^2$ ,  $\omega = -5 \text{ rad/sec}$ ,  $m = 50 \text{ kg}$

$L = 4 \text{ m}$ ,  $\theta = 10^\circ$

Find:  $M$ ,  $O_x$ ,  $O_y$

Solution: The bar's centroidal moment of inertia of the bar

$$\bar{I} = \frac{1}{12} m L^2 = \frac{1}{12} (50 \text{ kg})(4 \text{ m})^2 = 66.67 \text{ kg} \cdot \text{m}^2$$

Free body diagrams of the bar at this instant are shown below

## Chapter 1: Introduction

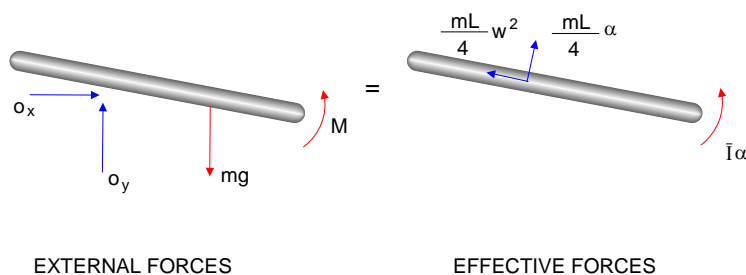

### Summing moments about O

$$\begin{aligned}
 (\sum M_O)_{ext.} &= (\sum M_O)_{eff.} \\
 M - mg \frac{L}{4} \cos \theta &= \bar{I} \alpha + m \frac{L}{4} \alpha \frac{L}{4} \\
 M &= (\bar{I} + m \frac{L^2}{16}) \alpha + mg \frac{L}{4} \cos \theta \\
 &= [66.67 \text{ kg} \cdot \text{m}^2 + \frac{(50 \text{ kg})(4 \text{ m})^2}{16}] (14 \frac{\text{rad}}{\text{sec}^2}) \\
 &\quad + \frac{(50 \text{ kg})(9.81 \frac{\text{m}}{\text{sec}^2})(4 \text{ m})}{4} = 2120 \text{ N} \cdot \text{m}
 \end{aligned}$$

### Summing forces in the horizontal direction

$$\begin{aligned}
 (\sum F_x)_{ext.} &= (\sum F_x)_{eff.} \\
 O_x &= -m \frac{L}{4} \omega^2 \cos \theta + m \frac{L}{4} \alpha \sin \theta \\
 &= -\frac{(50 \text{ kg})(4 \text{ m})}{4} (-5 \frac{\text{rad}}{\text{s}})^2 \cos 10^\circ \\
 &\quad + (50 \text{ kg}) \frac{4 \text{ m}}{4} (14 \frac{\text{rad}}{\text{s}^2}) \sin 10^\circ = -1110 \text{ N}
 \end{aligned}$$

### Summing forces in the vertical direction

$$(\sum F_y)_{ext.} = (\sum F_y)_{eff.}$$

$$O_y - mg = m \frac{L}{4} \omega^2 \sin \theta + m \frac{L}{4} \alpha \cos \theta$$

$$O_y = \frac{(50 \text{ kg})(4 \text{ m})}{4} \left(-5 \frac{\text{rad}}{\text{s}}\right)^2 \sin 10^\circ + \frac{(50 \text{ kg})(4 \text{ m})}{4} \left(14 \frac{\text{rad}}{\text{s}^2}\right) \cos 10^\circ + (50 \text{ kg})(9.81 \frac{\text{m}}{\text{s}^2}) = 1400 \text{ N}$$

Problem 1.17 illustrates application of Newton's Laws to rigid bodies.

**1.18** The disk of Figure P1.18 rolls without slipping. Assume if  $P = 18 \text{ N}$ . (a) Determine the acceleration of the mass center of the disk. (b) Determine the angular acceleration of the disk.

Given:  $m = 18 \text{ kg}$ ,  $P = 18 \text{ N}$ ,  $r = 20 \text{ cm}$

Find:  $\bar{a}$

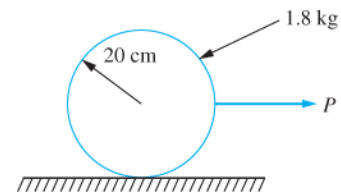
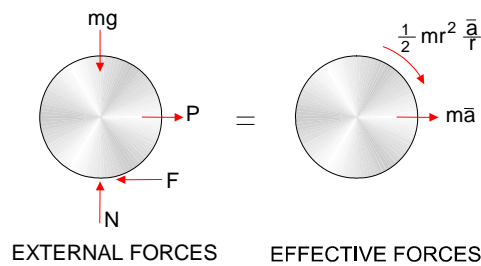

FIGURE P1.18

Solution: (a) If the disk rolls without slip then its angular acceleration is related to the acceleration of the mass center by

$$\bar{a} = r\alpha$$

Free-body diagrams of the disk at an arbitrary instant are shown below



Summing moments about the contact point

$$\begin{aligned} (\sum M_c)_{ext.} &= (\sum M_c)_{eff.} \\ Pr &= \bar{I}\alpha + m\bar{a}r \\ Pr &= \frac{1}{2}mr^2 \frac{\bar{a}}{r} + m\bar{a}r \\ \bar{a} &= \frac{2P}{3m} = \frac{2(18\text{ N})}{3(1.8\text{ kg})} = 6.67 \frac{\text{m}}{\text{s}^2} \end{aligned}$$

(b) The angular acceleration of the disk is

$$\alpha = \frac{\bar{a}}{r} = 33.35 \text{ r/s}^2$$

Problem 1.18 illustrates application of Newton's Laws to a rigid body.

**1.19** The coefficient of friction between the disk of Figure P1.18 and the surface is 0.12. What is the largest force that can be applied such that the disk rolls without slipping?

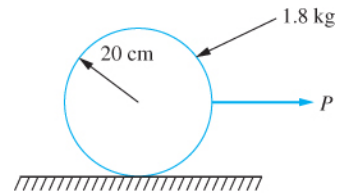
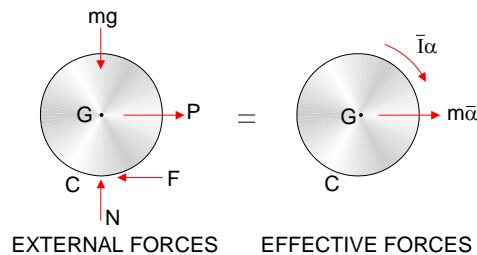

FIGURE P1.18

Given:  $m = 1.8 \text{ kg}$ ,  $r = 20 \text{ cm}$ ,  $\mu = 0.12$

Find:  $P_{\text{max.}}$  for no slip

Solution: Free body diagrams of the disk at an arbitrary instant are shown below.



Summing moments about the contact point,

$$\begin{aligned} (\sum M_c)_{ext.} &= (\sum M_c)_{eff.} \\ Pr &= \bar{I}\alpha + m\bar{a}r \end{aligned} \tag{1}$$

If the disk rolls without slip then

$$\alpha = \frac{\bar{a}}{r} \tag{2}$$

Substitution of eq.(2) into eq.(1) leads to

$$\bar{a} = \frac{2P}{3m} \tag{3}$$

Summing moments about the mass center of the disk

$$\begin{aligned} (\sum M_G)_{ext.} &= (\sum M_G)_{eff.} \\ F r &= \frac{1}{2} m r^2 \frac{\bar{a}}{r} \\ F &= \frac{1}{2} m \bar{a} = \frac{1}{2} m \frac{2P}{3m} = \frac{P}{3} \end{aligned}$$

The maximum allowable friction force is  $\mu mg$ , thus in order for the no slip assumption to be valid,

$$\begin{aligned} \frac{P}{3} &< \mu mg \\ P &< 3 \mu mg = 6.36 \text{ N} \end{aligned}$$

Problem 1.19 illustrates application of Newton’s Laws to a rigid body dynamics problem and rolling friction.

**1.20** The coefficient of friction between the disk of Figure P1.18 and the surface is 0.12. If  $P = 22 \text{ N}$ , what are the following? (a) Acceleration of the mass center. (b) Angular acceleration of the disk.

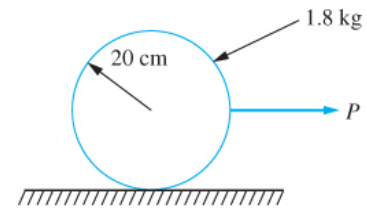
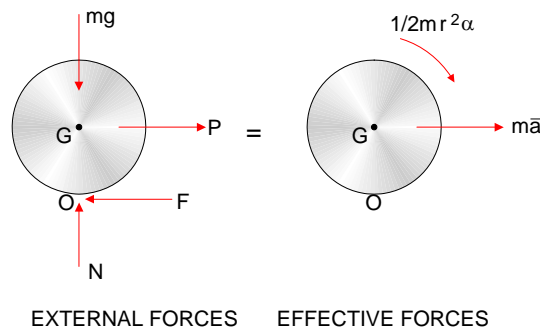

FIGURE P1.18

Given:  $r = 20 \text{ cm}$ ,  $m = 1.8 \text{ kg}$ ,  $P = 15 \text{ N}$ ,  $\mu = 0.12$

Find:  $\bar{a}$ ,  $\alpha$

Solution: (a) Free body diagrams of the disk at an arbitrary instant of time are shown below



Summing moments about the contact point between the disk and the surface

$$\begin{aligned}
 (\Sigma M_O)_{ext.} &= (\Sigma M_O)_{eff.} \\
 Pr &= m\bar{a}r + \frac{1}{2}mr^2\alpha
 \end{aligned}
 \tag{1}$$

Summing moments about the mass center

$$\begin{aligned}
 (\Sigma M_G)_{ext.} &= (\Sigma M_G)_{eff.} \\
 Fr &= \frac{1}{2}mr^2\alpha
 \end{aligned}
 \tag{2}$$

First assume the disk rolls without slipping. Then the velocity and the acceleration of the contact point are zero, which in turn implies that  $\bar{a} = r\alpha$ . Substituting into eq.(1) yields

$$\alpha = \frac{2P}{3mr} = 27.8 \frac{\text{rad}}{\text{s}^2}$$

If the assumption of no slip is valid, then the friction force developed is less than the maximum allowable friction force,

$$F_{\max} = \mu mg = 2.12 \text{ N}$$

The friction force assuming no slip is calculated using eq.(2),

$$F = \frac{1}{2}mr\alpha = \frac{1}{2}(1.8 \text{ kg})(0.2 \text{ m})\left(27.8 \frac{\text{rad}}{\text{s}^2}\right) = 5.0 \text{ N}$$

(b) Thus the disk rolls and slides. The friction force takes on its maximum permissible value of 2.12 N. The velocity of the contact point is not zero and is independent of the velocity of the mass center implying that there is no kinematic relation between the angular acceleration and the acceleration of the mass center. Setting  $F = 2.12 \text{ N}$  in eq.(2) leads to

$$\alpha = \frac{2F}{mr} = \frac{2(2.12 \text{ N})}{(1.8 \text{ kg})(0.2 \text{ m})} = 11.8 \frac{\text{rad}}{\text{s}^2}$$

Problem 1.20 illustrates application of Newton's Law to a rolling rigid body. Since it is not known whether the disk slides while rolling, an assumption of no slip is made. The assumption is proved false by checking the friction force. If an assumption of rolling and slipping is first made, there is no convenient way to check the assumption.

**1.21** The 3 kg block of Figure P1.21 is displaced 10 mm downward and then released from rest. (a) What is the maximum velocity attained by the 3-kg block? (b) What is the maximum angular velocity attained by the disk?