

CHAPTER 1

- 1.2 a) This is a four-bar linkage
 b) motion generation. The "output" link is path like drum striker and angle of
 c)

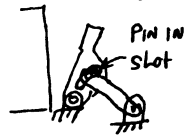

- 1.3 a) Function generation. Input handle moves output shear slider



- c) four-bar slider

- 1.4 a) Watt II, the two ternary links are connected together and a ternary link is ground

- b) Function generation. The input and output links are pinned to ground.

- 1.5 a) Motion generation. The output link is not adjacent to ground. Also, the orientation of the window during its motion is of interest, it must move straight out away from the sill before it can rotate to its final position.

- b) There are 6 links and 7 F_1 pin joints.

$$F = 3(6-1) - 2(7) = 15 - 14 = +1$$

- c) Stephenson I, the two ternary links are not adjacent to each other. Also, the ground link is a binary connected to two ternary links.

- 1.6 An adjustable four bar linkage

Function generation. Although the input link is not adjacent to ground, the output link is. Also, the task is to move the output link to a closed position when the input link is moved.

Because the output link must be moved first by larger than smaller angles per increment of input rotation of the handle in order to grip the workpiece quickly and to get a high force amplification between the vice jaws and the handle.

The function of the adjusting screw is to make the vice grips to be able to clamp the different size workpieces with approximately the same force amplification. It is located in the base link, because changing the length of the base link is the best way in which the force amplification can be kept approximately the same for different size workpieces.

- 1.7 Function generation, both the input and output links are pinned to ground.

Because the output link must rotate in a prescribed relationship with the input link.

1.8 a,

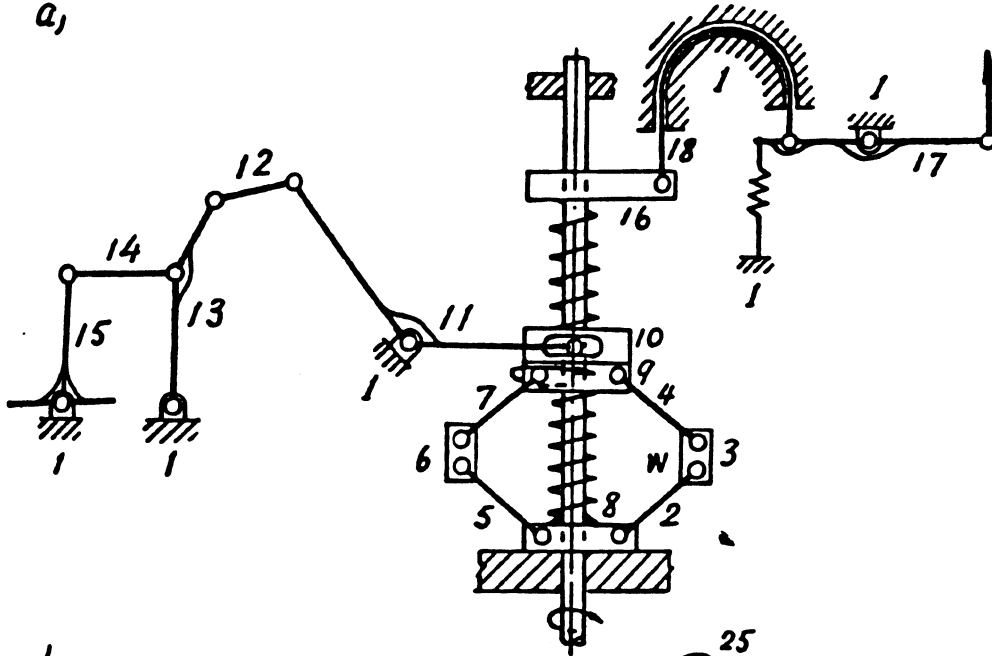

b)

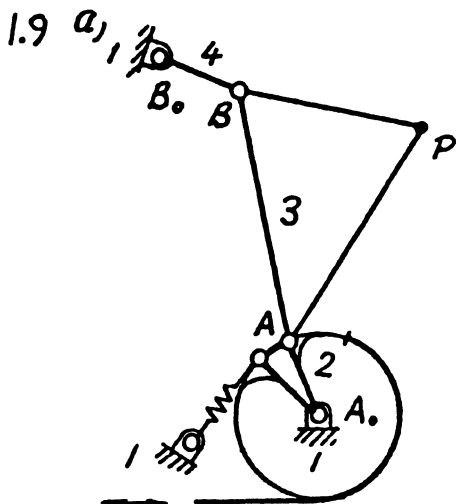
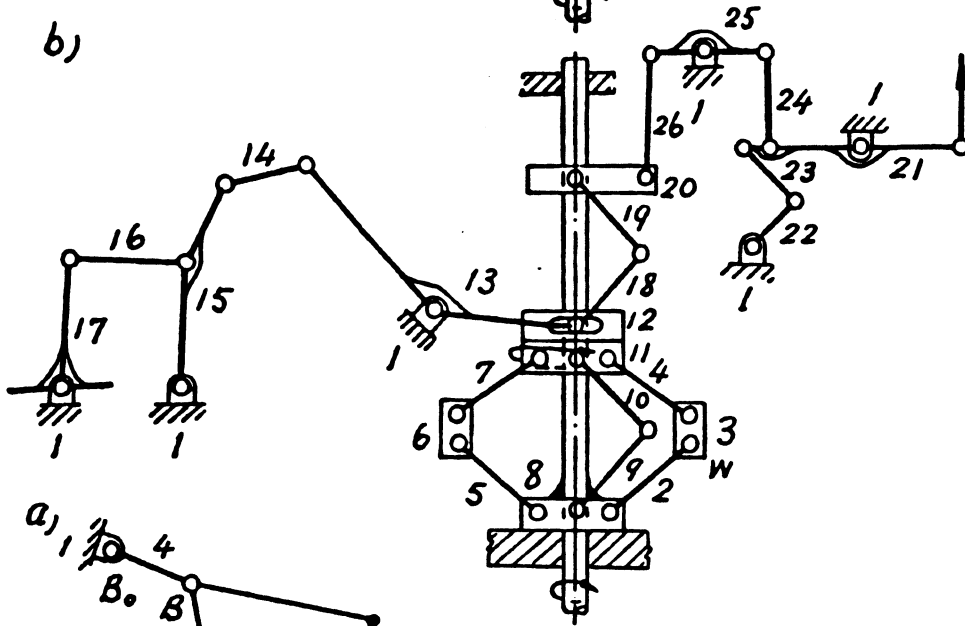

b, A path generator linkage

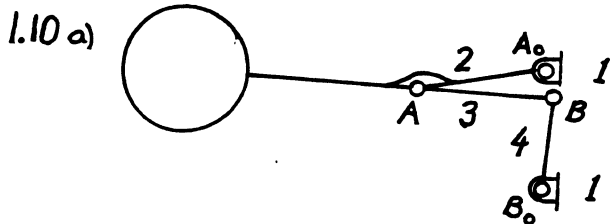

b) A function generator
input and output links are
pinned to ground.

1.11 a) A motion generator

b) Because a linkage can work in the adverse circumstances

c) Stability in running of the car, since it guides the wheels straight up and down as the car runs over an uneven road.

1.12 a) A four bar linkage

b) Function generation

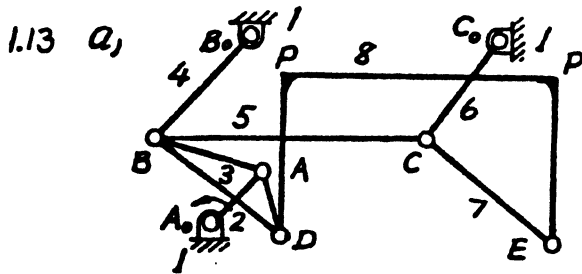

The kinematic diagram of the linkage shown in Fig. P1-13

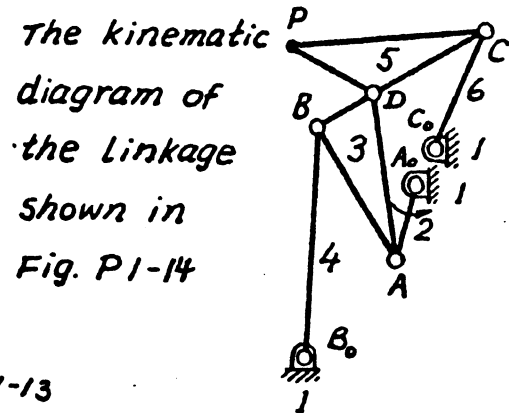

b) Stephenson III

1.14 a) For the linkage shown in Fig. P1.15
Function generation

b) $F = 3(7-1) - 2(8) = +2$

c) None, the "Watson" 7-bar

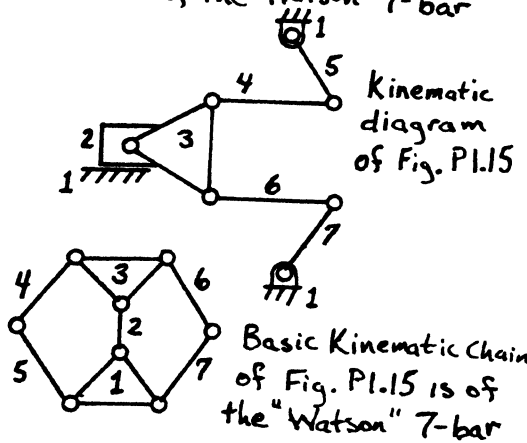

For the linkage shown in Fig. P1.16
Motion generation, jaws move parallel

$F = 3(8-1) - 2(9) - 1(2) = +1$

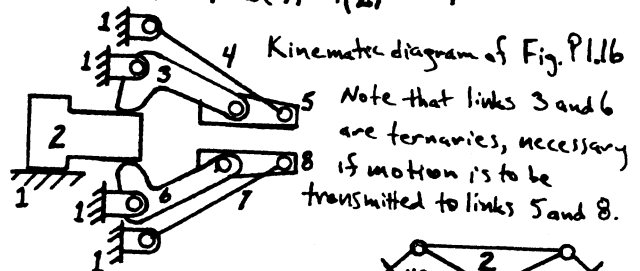

Basic Kinematic Chain of Fig. P1.16. "HS" is fictitious link which replaces higher pair slider gear joint. This topology consists of 3 concatenated Watt II six-bar linkages.

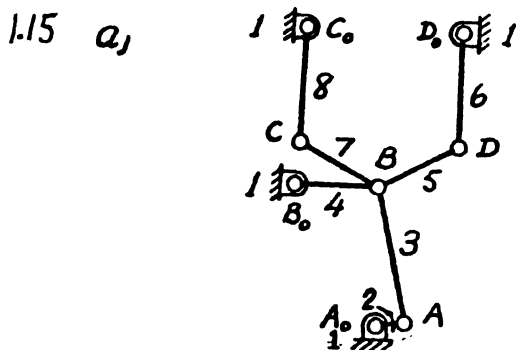

b) By Gruebler's equation:

$n = 8$

$p = 10$

$F = 3(8-1) - 2 \times 10$

$= 1$

1.15 b) *By intuition.*

Links 1 through 4 form a four-bar linkage which has a single degree of freedom. Once the input rotation of link 2 is specified, the position of point B is known with respect to A_0 , B_0 , C_0 and D_0 . BCC_0 and BDD_0 form two "rigid" triangles respectively and the mechanism is entirely specified.

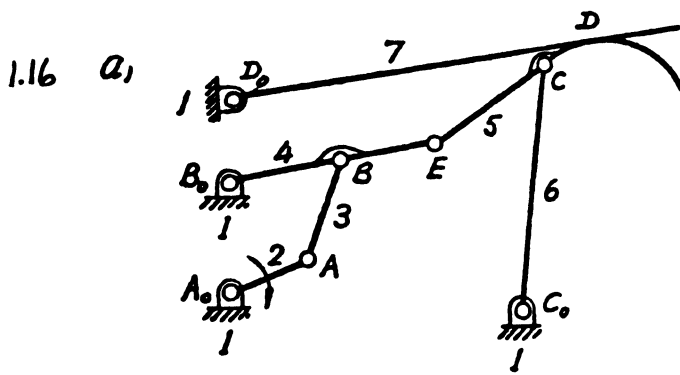

Harvey linkage

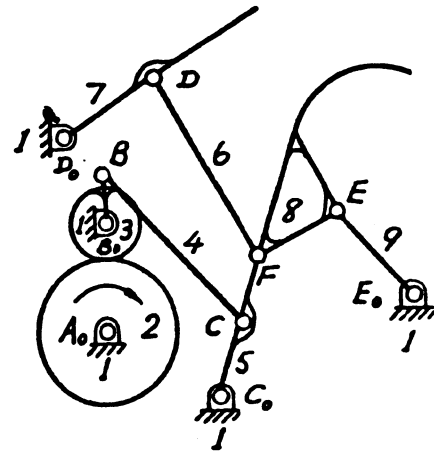

Bjorklund linkage

b) $n = 7$

$P = 8$

$S = 1$

$F = 3(7-1) - 2 \times 8 - 1 = 1$

c) *Watt II; Motion generation.*

$n = 9$

$P = 11$

$S = 1$

$F = 3(9-1) - 2 \times 11 - 1 = 1$

1.17 a) *Stephenson I*

b) *Motion generation*

1.18 a) *Watt II*

b) *Function generation*

c) *Because greater angles of output oscillation are wanted than possible with a four-bar linkage, in order to get complete agitation.*

1.19 a) *Watt I* b)

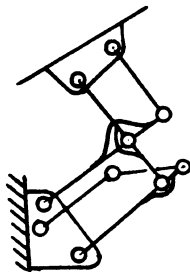

1.20 a) If the open chain retractor ends are neglected the kinematic diagram would be:

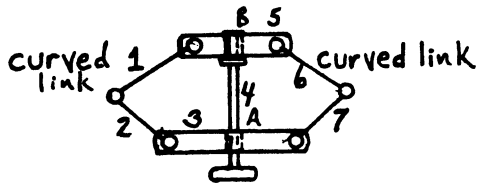

Kinematic diagram of Fig P1.30

$$DoF = 3(7-1) - 2(8) = +2$$

Joint A is a screw pair, 1 DOF

Joint B is a revolute pair, 1 DOF

Due to the screw pair, this mechanism cannot be backdriven.

This is actually a 2 1/2 dimension linkage, 2-D joints distributed in a 3-D manner.

The 2 freedoms come from using the 2-D grübler equation in 2 1/2 D space. One freedom reflects the internal planar motion and the second is from an out-of-plane motion.

b) c) There are no six-bar mechanisms in this 7-bar "Watson" topology regardless of which links, either 1 or 4 or any others, are grounded

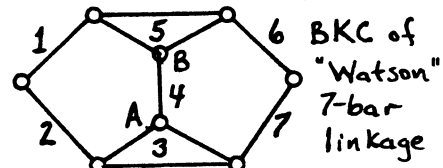

Note that the axes of joints A and B have been turned 90° into the plane.

1.21 a) Function generation, input and output links are pinned to ground

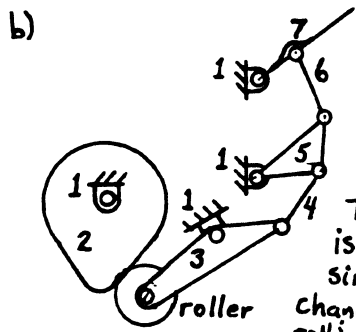

Kinematic diagram of Fig. P1.31

The roller link is not counted since it merely changes sliding into rolling motion.

Basic Kinematic Chain of Fig. P1.31

"HS" is a

fictitious link meant to model the f_2 higher pair sliding joint between links 2 and 3 or the roller link, which is supposed to allow a rolling motion, f_1 joint.

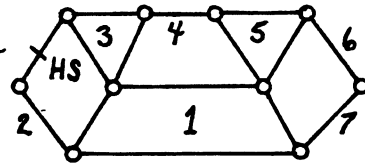

c) There are 2 Watt II six-bar linkages melded together sharing links 3, 4 and 5

d) Six (and this eight-bar) link mechanisms with the Watt II topology allow a very large output link rotation (here 180°) while preserving good transmission angles and good motion characteristics in general.

1.22 a) This question strikes the heart of how we analyze multiple-jointed linkages; note that there is no definitive ruling on this question. It could be either a Watt II or Stephenson III. The Watt II enjoys a slight edge because its topology is of 2 4-bars, which is what we see here.

b) $F = 3(7-1) - 2(8) = +2$, required for adjustable mechanisms

1.23 a)

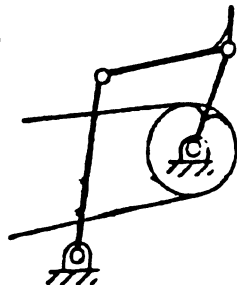

(1) Step 1

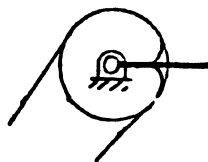

Step 2

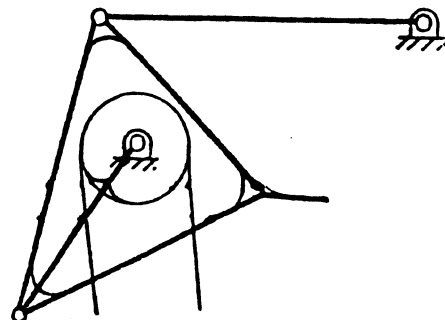

Step 3

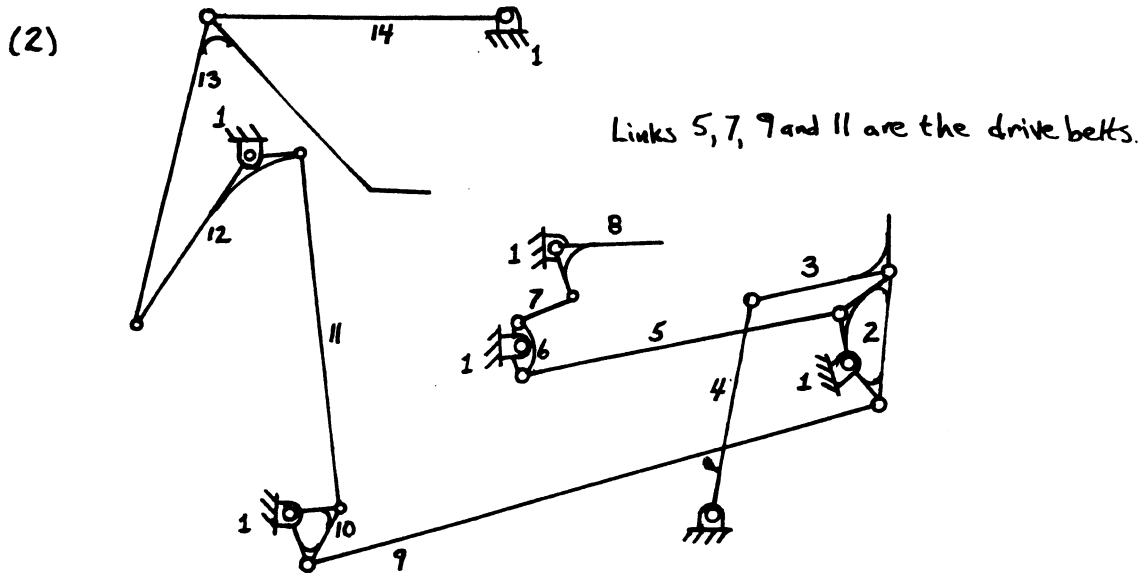

- 1.23 b) Step 1: Path generation
 Step 2: Motion generation
 Step 3: Motion generation

c) $F = 3(14-1) - 2(19) = +1$

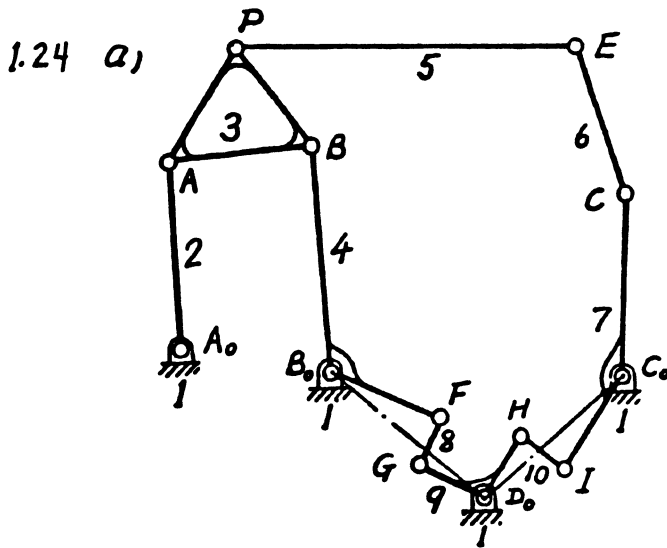

b) $n = 8$
 $P = 9$
 $S = 2$
 $F = 3(8-1) - 2 \times 9 - 1 \times 2 = 1$

$n' = 10$
 $P' = 13$
 $F' = 3(10-1) - 2 \times 13 = 1$
 $F' = F$

1.25 a) Stephenson III

- b) The kinematic diagram is drawn on next page.
 (1) The range of rotation of the input link is $\Delta\phi$.
 (2) The linkage indeed does hit the ink pad and produce an approximate straight line, approaching to and receding from the box.

c) Yes.

Because it can satisfy the requirements of motion with a minimum number of links.

d) If $|L_3 - L_2| < (S_{A_0 - D_i})_{min}$, the range of rotation of the input link would be changed. If $|L_3 - L_2| > (S_{A_0 - D_i})_{min}$, the linkage would not hit the ink pad, (cont'd on p.8)

1.25 b)

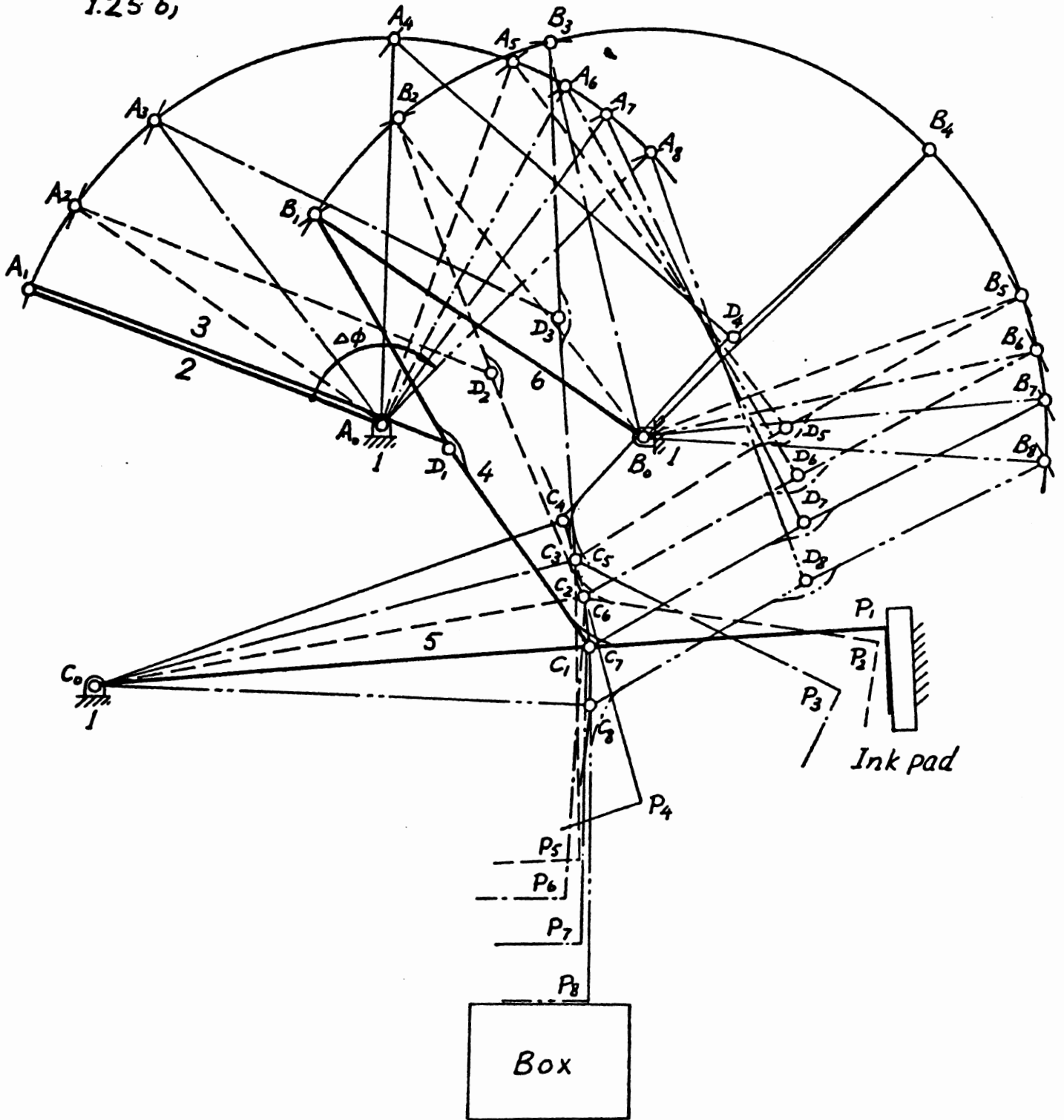

where L_3 and L_2 are the lengths of Link 3 and Link 2 respectively; $(S_{A_0-D})_{min}$ is the shortest distance from the input pivot A_0 to the locus of joint D between the initial and final positions.

1.26 a)

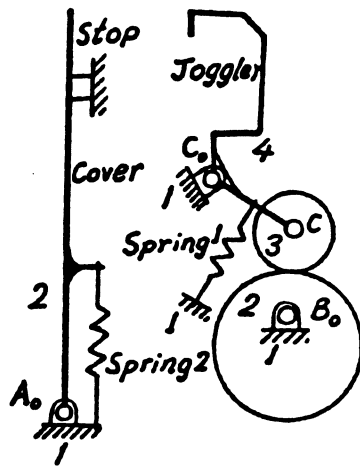

b)

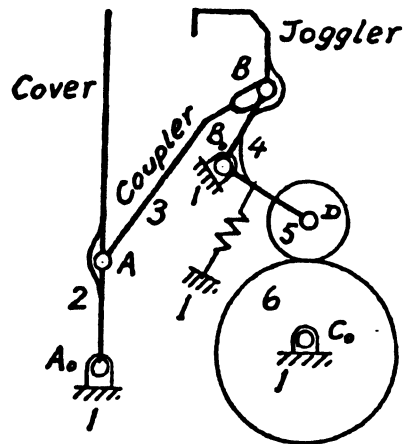

b) A coupler is added between the cover and the jogger, and the stop and spring 2 are removed.

c) For Fig. P 1.32 (Part a),

For the cover: $n=2$ $P=1$

$$F = 3(2-1) - 2 \times 1 \\ = 1$$

For the jogger: $n=4$ $P=3$ $S=1$

$$F = 3(4-1) - 2 \times 3 - 1 \\ = 2 \quad (\text{One of them is redundant})$$

For Fig. P 1.33 (Part b),

$n=6$ $P=5$ $S=2$

$$F = 3(6-1) - 2 \times 5 - 2 \\ = 3 \quad (\text{One of them is redundant})$$

1.26 d)

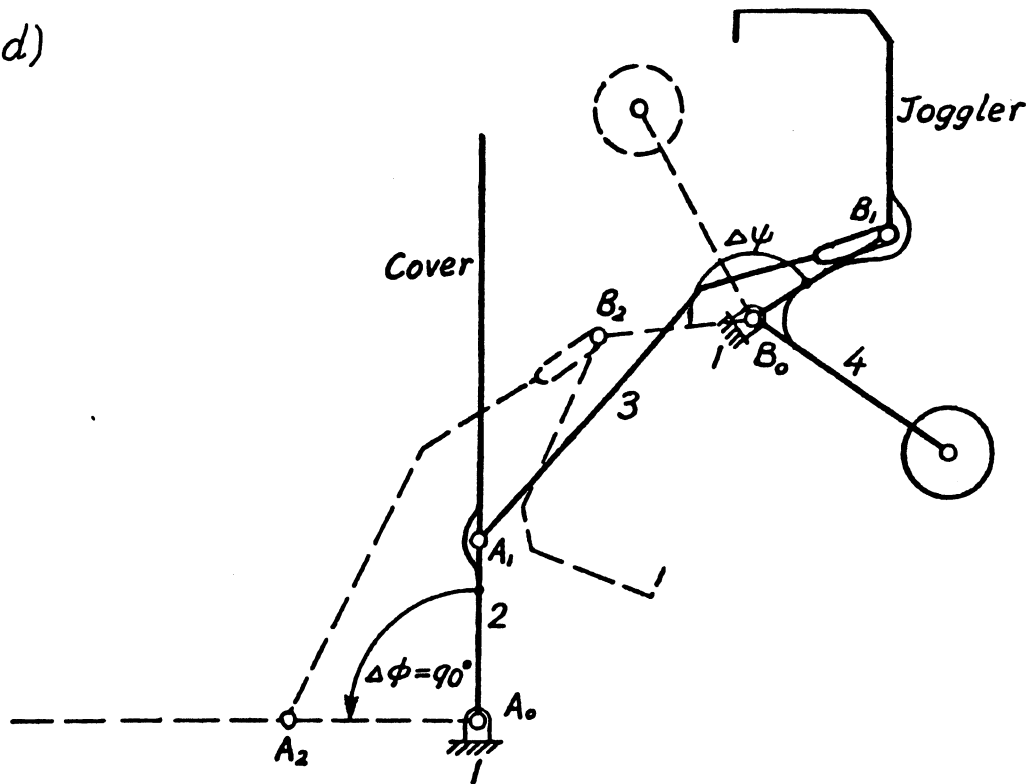

1.27 a)

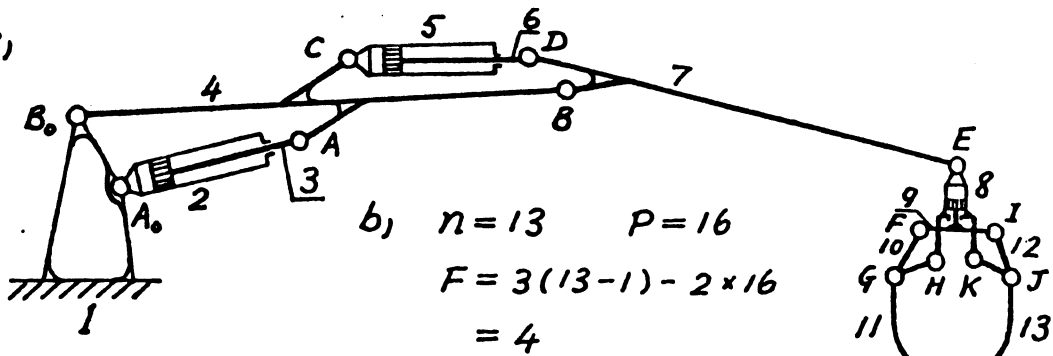

1.28 a)

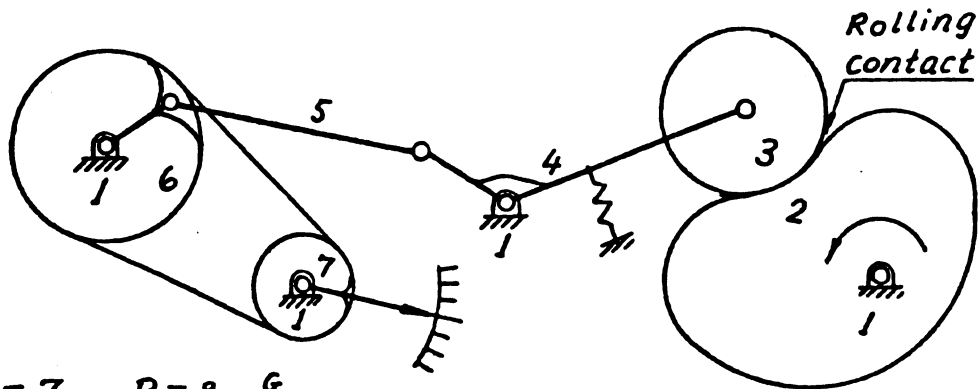

b) $n = 7$ $P = 8$
 $S = 1$ $F =$
 $3(7 - 1) - 2 \times 8 - 1 = 1$
 $n' = 10, P' = 13, F' =$
 $3(10 - 1) - 2 \times 13 = 1$
 $F' = F$

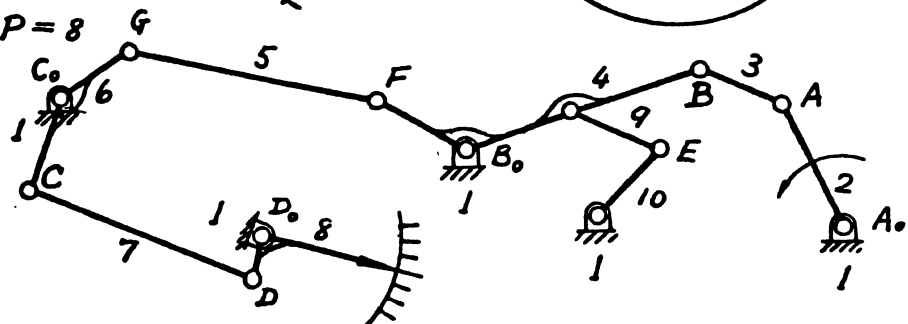

1.29 a)

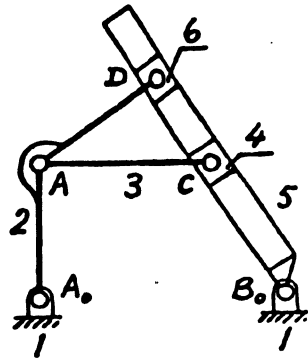

b) For the original linkage:

$$n=4 \quad p=3 \quad s=2$$

$$F=3(4-1)-2 \times 3-2=1$$

For the lower pair equivalent

$$\text{linkage: } n'=6 \quad p'=7$$

$$F'=3(6-1)-2 \times 7=1=F$$

1.30 a)

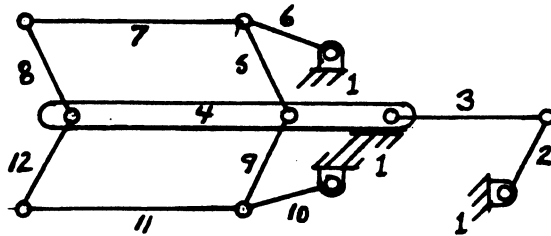

Kinematic diagram of Fig. P1.44

b) $F=3(12-1)-2(16)=+1$

Link 2 is the input link and links 7 and 11 are the output. Note that link 4 slides on link 1, this is to not allow the dilator blades to be forced as a complete unit into a sideways motion while in use. Also, the slot in link 4 is to allow links 5 and 9 to collapse into a smaller volume, it is only a clearance slot, not an f_2 slider slot.

1.31 a)

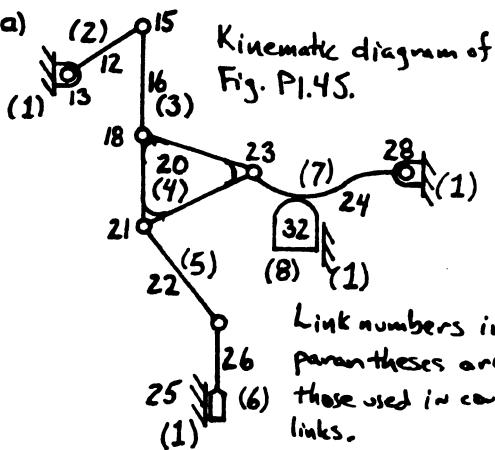

Kinematic diagram of Fig. P1.45.

Link numbers in parentheses are those used in counting links.

b) The joint between links 25 and 26 is an f_1 sliding joint. The flexible hose joint between links 22 and 26 is modelled as an f_1 pin joint.

c) $F=3(8-1)-2(9)-1(1)=+2$

The two inputs are:
- drive shaft 13, and
- swing-arm 24.

1.32 a)

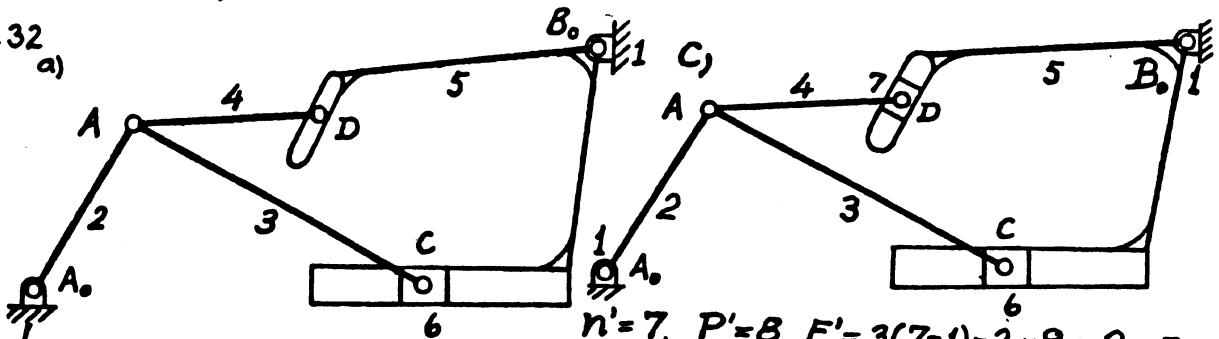

$$n'=7, \quad p'=6, \quad F'=3(7-1)-2 \times 6=2=F$$

b) $n=6, \quad p=6, \quad s=1 \quad F=3(6-1)-2(6)-1(1)=+2$