

# CHAPTER 1

## History and Classifications of Aero-engines

1.1 Since the first flight of Wright brothers in 1903 and until now, endless developments in aircraft and engine industries have been achieved. It is required to identify some milestones in such a long journey by listing the FIRST engines of the following categories:

Turbojet engine, turbojet engine with afterburner, turbofan engine, supersonic turbofan engine, high bypass ratio turbofan engine, turboprop engine and prop fan engine.

### Solution

#### **A- Turbojet Engine**

Turbojet engines are the simplest and oldest jet engines. Two engineers, Frank Whittle in the United Kingdom and Hans von Ohain in Germany, developed the concept independently during the late 1930s.

#### **German inventor von Ohain**

On 27 August 1939 the German aircraft Heinkel He 178 became the world's first aircraft to fly powered by a single turbojet engine HeS3 having a thrust force of 4.4 kN (992 lbf) invented by von Ohain.

#### **Parts :**

1-Intake                      2-Centrifugal compressor                      3-Annular combustion chambers  
4-Axial turbine              5-Nozzle

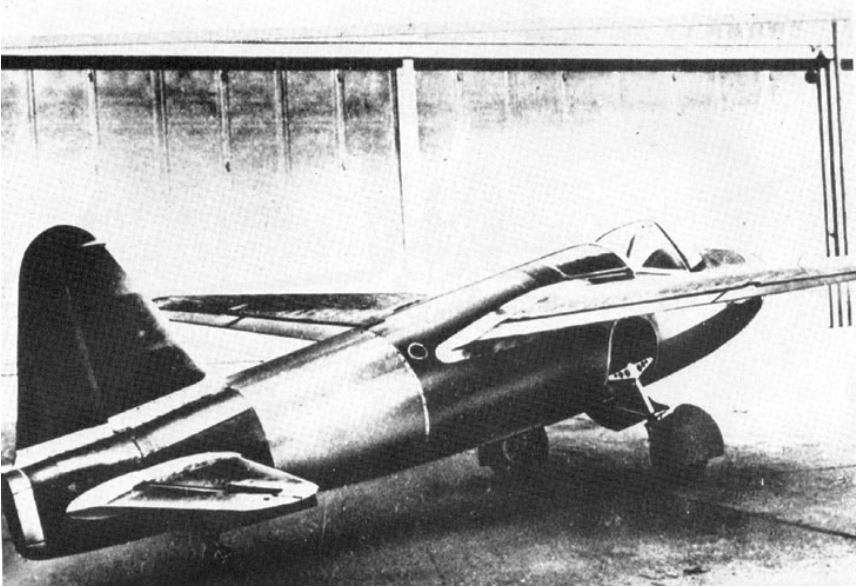

Developments to the HeS3 engines resulted in HeS 3b having the properties:

**Dimensions:** 1.48 m long, 0.93 m diameter

**Weight:** 360 kg

**Thrust:** 4.4 kN at 13,000 rpm and speed 800 km/h

**Compression ratio:** 2.8:1

**Specific fuel consumption:** 2.16 gal/(lb·h) [18.0 L/(kg·h)]

### **British inventor Frank Whittle**

Concerning the **British** inventor Frank Whittle, his first engine W.1-powered the aircraft Gloster E.28/39 on May 15, 1941, which took off from Cranwell at 7.40 pm, flying for seventeen minutes and reaching a maximum speed of around 545 km/h (340 mph). Within days it was reaching 600 km/h (370 mph) at 7,600 meters.

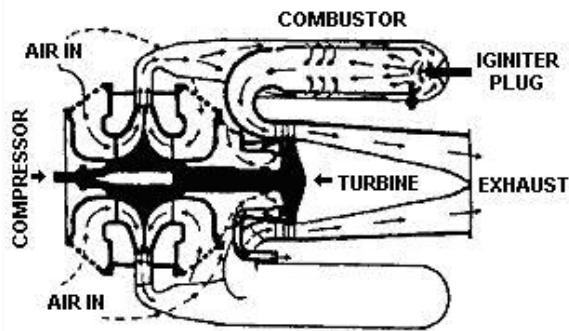

Whittle's Reverse-Flow  
Combustion Chamber

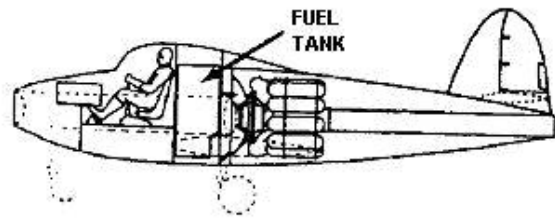

Fuselage Arrangement of the  
E28/39 Experimental

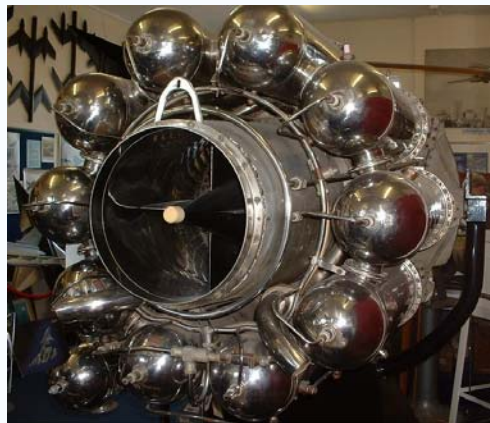

W-2B engine

A newer design known as the W.2 was next started. The W.2B passed its first 100 hour test at full performance of 725 kgf (7.11 kN) on May, 7, 1943. The prototype

Meteor airframe was already complete and took to the air on June 12, 1943.

Production versions started rolling off the line in October, first known as the

W.2B/23, then the RB.23 (for Rolls-Barnoldswick) and eventually the Whittle W-2/700

Rolls-Royce Welland. Barnoldswick was too small for full-scale production and turned back into a pure research facility under Hooker, while a new factory was set up in Newcastle-under-Lyme. The W.2B/26, as the Rolls-Royce Derwent, opened the new line and soon replaced the Welland, allowing the production lines at Barnoldswick to shut down in late 1944.

The first operational turbojet fighter aircrafts were the German Messerschmitt Me 262 and the British Gloster Meteor entered service towards in 1944. The Me 262 was produced in World War II and saw action starting in 1944 as a multi-role fighter / bomber / reconnaissance / interceptor warplane for the Luftwaffe.

## **B-Turbojet engine after burner**

An **afterburner** is an additional component added to some jet engines, primarily those on military aircraft. The Jumo 004 engine variation, **004C**, included an afterburner for increased thrust in the design, but was never built. It was also considered for the Miles M.52 project during the last years of World War II (never completed nor tested) where it was called a **reheat jet pipe**. The first operational aircraft with afterburner was the Swedish SAAB J29 "Flying Barrel" in 1954; this was also the first aircraft to enter service with a swept wing configuration. For some years it held speed records due to its very advanced technology, adopted for the first time.

### **Parts :**

- 1- Intake
- 2- Compressor
- 3- Combustion chambers
- 4- Turbine
- 5- Afterburner
- 6- Nozzle



## **C- Turbofan Engines**

The **Rolls-Royce RB.80 Conway** was the first by-pass engine (or turbofan) to go into service in the world. The jet found only limited applications in the Handley Page Victor, the Vickers VC10, the Boeing 707-420 and the Douglas DC-8-40.

### **Parts:**

- 1-Fan
- 2- Compressor
- 3-Combusion chamber
- 4- Turbines
- 5-Nozzles

## **D- Supersonic Turbofan (Turbofan with afterburner)**

The first afterburning turbofan was the Pratt & Whitney TF30. The **TF30** powered the F-111 and the F-14A Tomcat. First flight of the TF30 was in 1964 and production continued until 1986.

The first GE augmented turbofan was F101-GE-102 rated in the 30,000 pound thrust class. It was delivered in 1983 and B-1B flight testing began in 1984.

## **E- High Bypass Ratio Turbofan Engines**

The first high-bypass turbofan engine was the General Electric TF39, built to power the Lockheed C-5 Galaxy military transport aircraft, which dates back to the 1960s. The engine was then offered for civilian use as the CF6. This high-bypass turbofan was a giant leap in aircraft engine design, offering high thrust levels (43,000 pounds) and revolutionary fuel efficiency. The TF39 included such pioneering technological accomplishments as an 8-to-1 bypass ratio, 25-to-1 compressor pressure ratio, a 2,500°F turbine temperature made possible by advanced cooling techniques, and a GE-designed thrust reverser.

Other high-bypass turbofans are the Pratt & Whitney JT9D, the three-shaft Rolls-Royce RB211 and the CFM International CFM56. More recent large high-bypass turbofans include the Pratt & Whitney PW4000, the three-shaft Rolls-Royce Trent 500, 700, 900 and 1000 , the General Electric GE90, GP7000 and the General Electric GEnx. The bypass ratio for Trent 1000 is 11:1. Near future turbofans are planned to reach 17:1.



**Trent 900**

The latest generation of high bypass ratio turbofans from General Electric, Pratt & Whitney and Rolls-Royce produce up to 512kN (115,000lb) of thrust

The Soviet Union's engine technology in the past used less bypass ratio engines than the West's and its first wide-body aircraft, the Ilyushin Il-86, was powered by low-bypass engines. The Yakovlev Yak-42, a medium-range, rear-engined aircraft seating up to 120 passengers was the first Soviet aircraft to use high-bypass engines.

## **F -Turbo-prop Engine**

The world's first turboprop was the 'Jendrassik Cs-1' designed by the Hungarian mechanical engineer György Jendrassik. It was produced and tested in the Ganz factory in Budapest between 1939 and 1942. It was planned to fit to the Varga RMI-1 X/H twin-engined reconnaissance bomber designed by László Varga in 1940, but the programme was cancelled. Jendrassik had also designed a small-scale 75 kW turboprop in 1937.

The first British turboprop engine was the Rolls-Royce RB.50 Trent; a converted Derwent II fitted with reduction gear and a Rotor of 7 ft 11 in five-bladed propeller. Two Trents were fitted to Gloster Meteor EE227— the sole "Trent-Meteor" — which became the first relatively reliable turboprop powered aircraft.



Rolls Royce RB.50 Trent

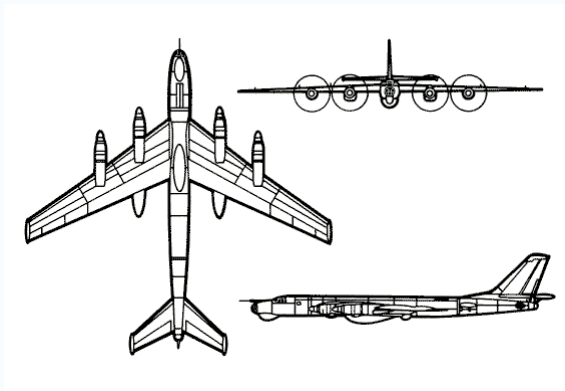

Tupolev\_Tu-95\_BEAR

The Soviet Union produced the Tu-95 'Bear', which uses 8 contra-rotating propellers (two per nacelle) with supersonic tip speeds to achieve maximum cruise speeds in excess of 575 mph, faster than many of the first jet aircraft, and comparable to jet cruising speeds for most missions.

### **Parts:**

1-Propeller    2-Gear box    3- Compressor    4-Combusion chamber  
5-Turbine(s)    6-Nozzle

## **G - Propfan Engine**

The **Progress D-27** is a propfan engine that the U.S.S.R Company developed in the 1980s for commercial and military transport aircraft. Unlike the General Electric GE-36 UDF propfan, the D-27 has a fairly conventional layout, with a reduction gearbox linking the power turbine to the contra-rotating propfan blades, which are located at the front of the engine (i.e. tractor configuration). Early work stalled because aviation fuel became cheap in real terms and of concerns about excessive cabin noise. D-27 powers the Antonov An-70 military transport.



An-70

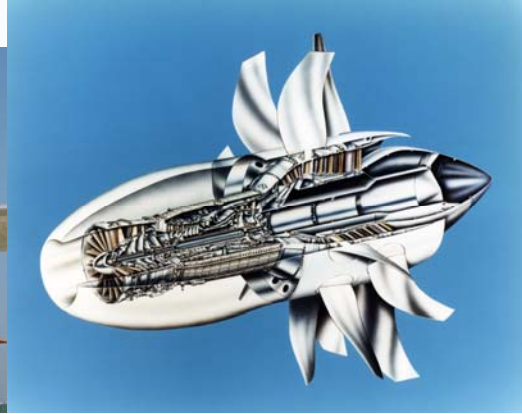

GE 36 UDF

NK-93. The KKBM NK-93 is a new-design ultra-high-bypass-ratio propfan of ducted contrafan tractor design; it reportedly has a bypass ratio of 16.6:1. The engine has a seven-stage IP compressor, eight-stage HP compressor, and three-stage LP turbine. Dimensions and units of measure are: fan diameter, 114 inches (2,896 mm); weight, dry, 8,047 pounds (3,650 kg). Maximum power at T-O is 39,700 lbst (176.5 kN). The engine model is proposed for long-range aircraft, and is a candidate for powering the Ilyushin Il-96M.

Two test flights of Russia's NK-93 ducted fan prototype engine have been completed on board an Ilyushin Il-76 flying test bed, and the engine could be ready for first deliveries in 2009.





Il-76LL used by LII to test the NK-93 ducted propfan

---

1.2 Do you think the hen and the egg eternal question applies for the aircraft and engine?

### **Solution**

NO. The eternal question of the hen and egg is not appropriate for aircraft and engine. There is no doubt as to which was necessary first. From the first day of manned flight, engine comes first. The lightweight and powerful engine enabled the mankind to design the appropriate vehicle structure for both civil and military aircrafts that fulfills their requested mission.

---

1.3 Describe the British and German patents for the first jet engines

### **Solution**

Frank Whittle was the first to register a patent for the turbojet engine in 1930. Hans von Ohain was granted a patent for his turbojet in 1936.

#### **Frank Whittle**

He was the first to register a patent for the turbojet engine on 16<sup>th</sup> January 1930 when age 22 and a Flying Instructor in the RAF. It was entitled:

## Improvements in Aircraft Propulsion.

The patent was granted in 1932.

The patent showed the air passing through a single- stage axial-flow compressor, then a centrifugal compressor, before entering a number of radially-arranged combustion chambers and exhausting through a 2 stage axial-flow turbine on the same shaft as the compressor. Modern small gas turbines follow a similar layout.

Once granted, the patent was published but lapsed when Whittle could not afford the renewal fee of £5.

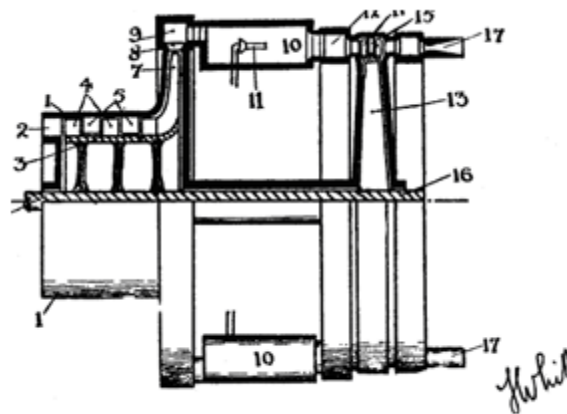

### Key:

- |                            |                  |                            |
|----------------------------|------------------|----------------------------|
| 1. Axial compressor casing | 2. Intake        | 3. Compressor body         |
| 4. Compressor blades       | 5. Stator blades | 7. Centrifugal compressor  |
| 8. Compressor outlet       | 9. Elbow         | 10. Combustion chambers    |
| 11. Fuel injector          | 13. Turbine disk | 14. Turbine blades         |
| 15. Stator blades          | 16. Shaft        | 17. Divergent nozzle ring. |

However he received very little encouragement from the Air Ministry or industry.

After receiving support from investment bankers, Power Jets was established in 1936

and Whittle was assigned to the company to work on the design and development of

his first jet engine.

The first run of the experimental engine was in April 1937. This engine has a centrifugal compressor and axial flow turbine. Many problems were encountered. Some were solved during the next year and the experimental engine was reconstructed several times. The resulting engine with ten combustion chambers performed well. In June 1939, the Air Ministry was finally convinced of the merits of Whittle's invention and decided to have a flight engine. Thus, the first Whittle flight engine was built and was called the Power Jet W.1.

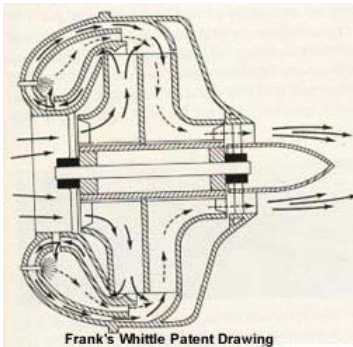

Frank Whittle patent 1930

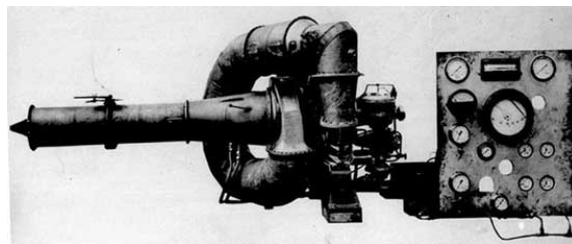

Frank Whittle first experimental engine run at April 1937

## Von Ohain

Hans von Ohain was granted a patent for his turbojet engine in 1936. He started development of the turbojet engine in the early 1930's while in the midst of his doctoral studies at Goettinger University in Germany. By 1935 he had developed a test engine to demonstrate his ideas. It is shown left below, and right with master mechanic Max Hahn. He asked Ernst Heinkel, an aircraft manufacturer for support Heinkel saw the promise in von Ohain's invention - a means to build the fastest airplane in the world. At the end of February 1937, the He S-1 turbojet engine with hydrogen fuel was tested and produced a thrust of 250 pounds at 10,000 rpm.

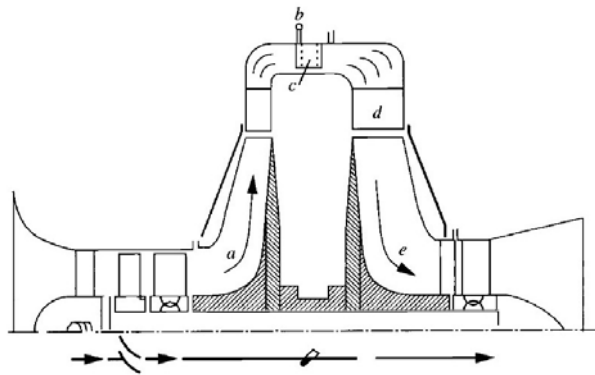

RADIAL TURBOJET (He S-1)  
WITH HYDROGEN  
(Built in 1936; tested in April 1937)

Radius of rotor-1 ft  
Thrust-250 lb  
10,000 rpm

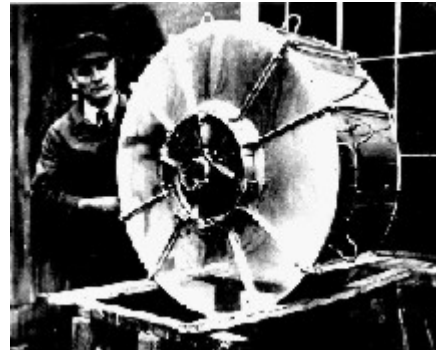

In 1936, von Ohain earned a patent on his version of jet engines, Process and Apparatus for Producing Airstreams for Propelling Airplanes. Unlike Frank Whittle's design, von Ohain's engine used a centrifugal compressor and turbine placed very close together, back to back, with the flame cans wrapped around the outside of the assembly. The resulting engine was even larger in diameter than Whittle's, although much shorter along the thrust axis.

Max Hahn, an automotive engineer, arranged for him to build a model of his engine, which cost about 1,000 DM. When it was complete he took it to the University for testing, but ran into serious problems with combustion stability. Often the fuel would not burn inside the flame cans, and would instead be blown through the turbine where it would ignite in the air, shooting flames out the back and overheating the electric motor powering the compressor

In April von Ohain and Hahn worked for Heinkel. Once moved, a study was made of the airflow in the engine, and several improvements made over a two month period. They produced a completely new engine Heinkel-Strahltriebwerk 1 (HeS 1) incorporating all of these changes, running on hydrogen gas. Hahn, meanwhile, worked on the combustion problem, an area he had some experience in.

The engine was extremely simple, made largely of sheet metal. Construction started late in the summer of 1936, and completed in March 1937. It ran two weeks later on hydrogen, but the high temperature exhaust led to considerable "burning" of the metal. The tests were otherwise successful, and in September the combustors were replaced and the engine was run on gasoline for the first time. This proved to clog up the combustors, so Hahn designed a new version based on his soldering torch, which proved to work much better.

So impressed with the engine tests, Heinkel pressed for an accelerated flight engine program. Von Ohain's team began development on the He S-3 engine. One of the main technology hurdles they faced was the development of a liquid fuel combustor. This resulted in the engine shown to the left with a front combustor. Detailed design began in early 1938 on the test aircraft, the He-178 (shown below).

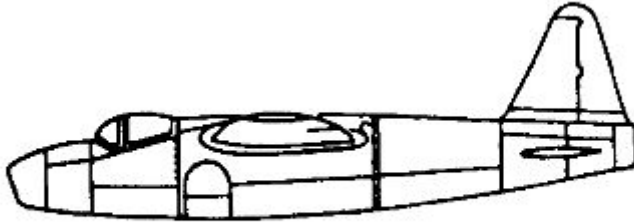

**The German Heinkel HE-178**

In early 1939, both the engine and the airframe were completed, but the net thrust was below requirements. After several internal engine adjustments, the engine was ready. On August 27, 1939, Heinkel's test pilot, E. Warsitz, made the first successful flight of a jet power aircraft.

---

## **1.4 Compare between the first engine invented by Frank Whittle and von Ohain**

### **Solution**

### **First engine invented by von Ohain**

Heinkel He 178 aircraft was fitted with a single Heinkel HeS 3b centrifugal flow turbojet generating some 1,102lbs of thrust. The reached top speeds of about 373 miles per hour.

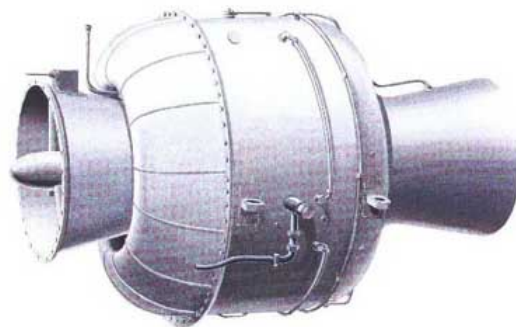

**He S-3 engine used to power the He-178 aircraft**

The He 178 featured an **open nose air intake** extending through to the extreme tail of the design. Wings were high-mounted on the fuselage with the cockpit extreme forward. The empennage was traditional with a single vertical tail surface. Landing gear were powered and closed up on either side of the forward front fuselage just in front of the wing assembly. A retractable tailwheel was also incorporated and sat between the main wing section and the tail section. The basic fuselage featured a semi-monocoque type fuselage of metal but was largely constructed of wood.

When the He 178 took to the skies on her maiden flight, the intake ingested a passing bird which in effect caused an engine failure, limiting any demonstration for some time despite a safe landing by the pilot. The program progressed with great promise, though weaknesses in the overall airframe design were soon becoming apparent. Nevertheless, the He 178 development would play a pivotal role in years to come, leading to the development of more efficient and stable platforms before war's end

## **First engine invented by Frank Whittle**

On 8 April 1941, the first test flight of the Gloster E.28/39 with "W.1" turbo-jet engine, invented by Sir Frank Whittle took off from the company's airfield at Hucclecote.

"W.1" engine produced 800 pounds of thrust. The aircraft reached 466 miles per hour and climbed to 42,000 feet, exceeding all speed and altitude limitations of that period.

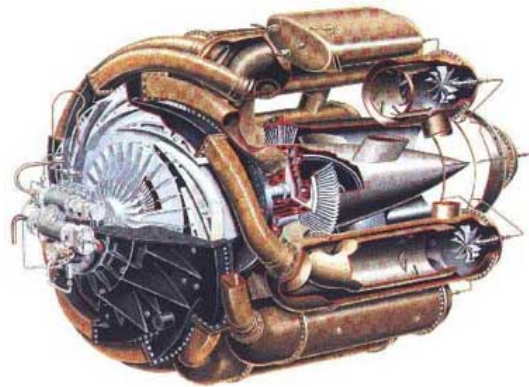

On April 12, 1941 W.1 engine having 3.8 kN (850 lbf) thrust ran, and on May 15, 1941 the W.1-powered E.28/39 took off from Cranwell at 7.40 pm, flying for seventeen minutes and reaching a maximum speed of around 545 km/h (340 mph). Within days it was reaching 600 km/h (370 mph) at 7600 meters.

The W.1 engine had a centrifugal compressor and featured a "reverse flow" design of the burners, in which the heated air from the flame cans was piped back towards the front of the engine before entering the turbine area. This allowed the engine to be "folded", with the flame cans lying around the turbine area, and therefore making for a shorter engine.



*The Gloster E28/39*

---

## 1.5 Complete the following table:

Name	Contribution
Hero	
Wan Hu	
Leonardo da Vinci	
Giovanni Branca	
Isaac Newton	
Felix de Temple	
John Barber	
Samuel Langley	
Wright brothers	
Frank Whittle	

### Solution

#### HERO'S ENGINE



Hero's turbine remained a curiosity for more than a thousand years. In the early 19th century, several inventors, including the steam engine builders James Watt and Richard Trevithick in England and Oliver Evans in America, experimented with steam reaction turbines of the Hero type, but without much success. It was in the 1830s that an obscure and now largely forgotten mechanic, William Avery, designed and built a Hero turbine that could manage significant, useful work. It powered several gristmills and sawmills in New York State, and even drove a locomotive.

## Wan Hu

He was a minor Chinese official of the Ming dynasty and perhaps (though not likely) the world's first astronaut.

According to legend, early in the 16th century, Wan decided to take advantage of China's advanced rocket and fireworks technology to launch him into outer space.

He had a chair built with forty-seven rockets attached. On the day of lift-off, Wan, splendidly attired, climbed into his rocket chair and forty seven servants lit the fuses and then hastily ran for cover. There was a huge explosion. When the smoke cleared, Wan and the chair were gone.



Legendary Chinese official Wan Hu braces himself for "liftoff"



He was never seen again.

## Leonardo Da Vinci

1- Leonardo Da Vinci designed a device called the "**chimney jack**" around the year 1500 AD. The chimney jack was used to turn a roasting skewer. This reaction-type turbine worked on the principle of heat raising gases from the roasting fire. As the hot air rose, it passed through fanlike blades that turned the roast through a series of gears.

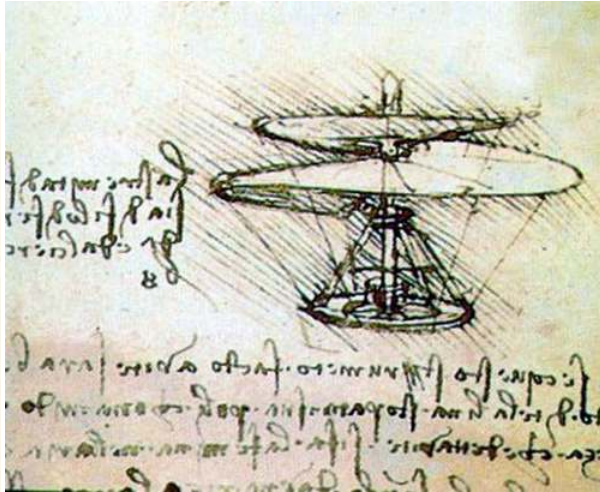
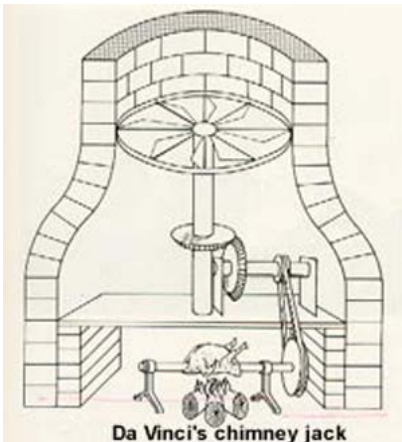

### Ornithopter Flying Machine (Helicopter)

2- He designed the **ornithopter** flying machine was never actually created. It was a design that Leonardo DaVinci made to show how man could fly. Some experts say that the modern day helicopter was inspired by this design.

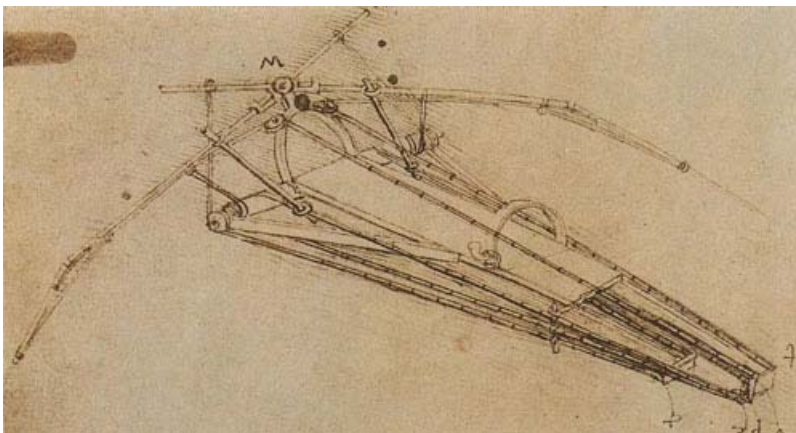

3- His studies on the possibilities of flight were shaped by the idea that man's own muscle power sufficed to imitate the flight of birds. For this reason, he conducted a number of experiments based on a design that could never be realized: a machine propelled by **flapping wings**.

### Branca's Stamping Mill

In 1629 an Italian engineer, Giovanni Branca, was probably the first to invent an actual impulse turbine. This device, a stamping mill, was generated by a steam-powered turbine. A jet nozzle directed steam onto a horizontally mounted turbine wheel, which then turned an arrangement of gears that operated his mill.

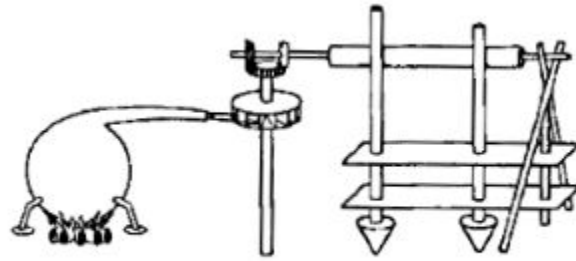

**Branca's Jet Turbine**

# Isaac Newton

## The Steam Wagon

In 1687 Isaac Newton attempted to put his newly formulated laws of motion to the test with his "steam wagon". He tried to propel the wagon by directing steam through a nozzle pointed rearward. Steam was produced by a boiler mounted on the wagon. Due to lack of power from the steam, this vehicle didn't operate.



**Newton's Steam Wagon**

# Felix de Temple

In 1857 a French naval officer, Félix Du Temple, aided by his brother Louis, designed a Monoplane powered aeroplane notable for a retractable three-wheeled undercarriage (landing gear) and the recommendation of a lightweight metal, aluminum. It had a 55ft wingspan and was 24ft long with swept-forward wings set at a slight dihedral angle (angled upward). Du Temple's model was first propelled by a clockwork engine and then by a steam engine. a "hot air" engine.

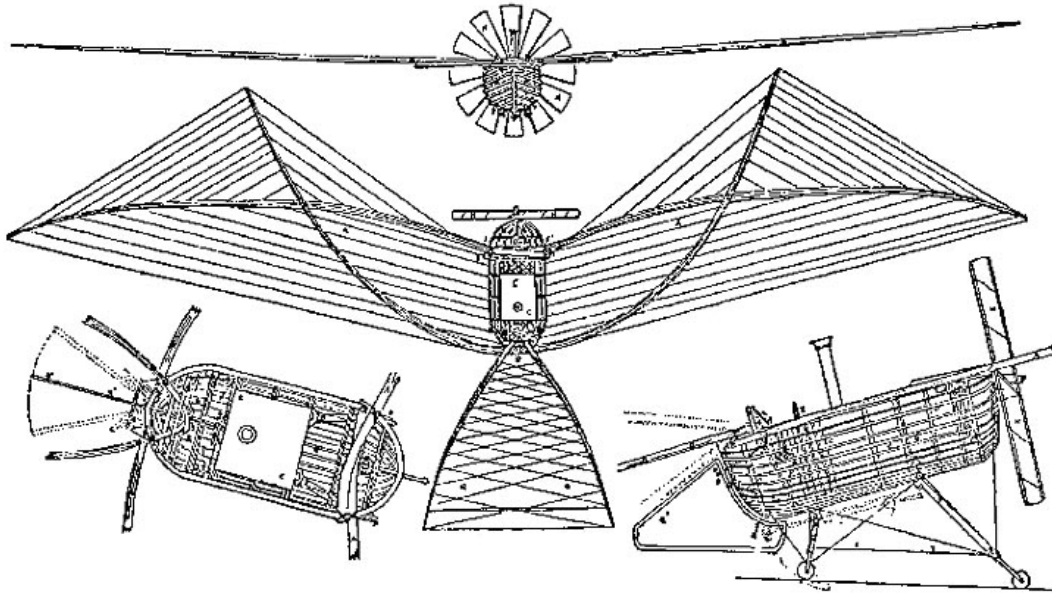

**Félix Du Temple de la Croix Monoplane design of 1857**

A model of du Temple's aircraft was tested with a French sailor as a pilot in 1874. Launched down a hill side and driven by a tractor propeller powered by steam, it was more of a "hop" than a real flight, but some historians give du Temple credit for the first powered flight.

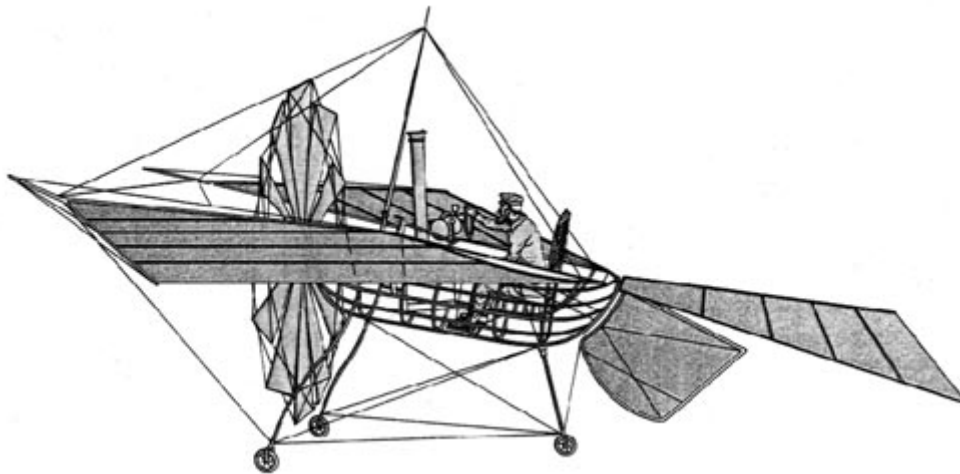

**Félix Du Temple de la Croix Monoplane of 1874**

The model managed to fly and to land. However, his attempts to achieve the same results with a full-scale plane were unsuccessful until 1874, because of the lack of an adequate propulsion system. In 1874, at Brest in Brittany, France, he successfully launched a bat-like plane with a steam engine carrying a sailor on board. Rising a few feet off the ground, it was the first launch of a manned, powered fixed-wing aircraft. However, the launch took place down a slope and was not pursued.

# John Barber

## The First Gas Turbine

In 1791 John Barber, an English man, was the first to patent a design that used the thermodynamic cycle of the modern gas turbine. His design contained the basics of the modern gas turbine it had a compressor, a combustion chamber, and a turbine. The main difference in his design was that the turbine was equipped with a chain-driven reciprocating type of compressor. He intended its use for jet propulsion.

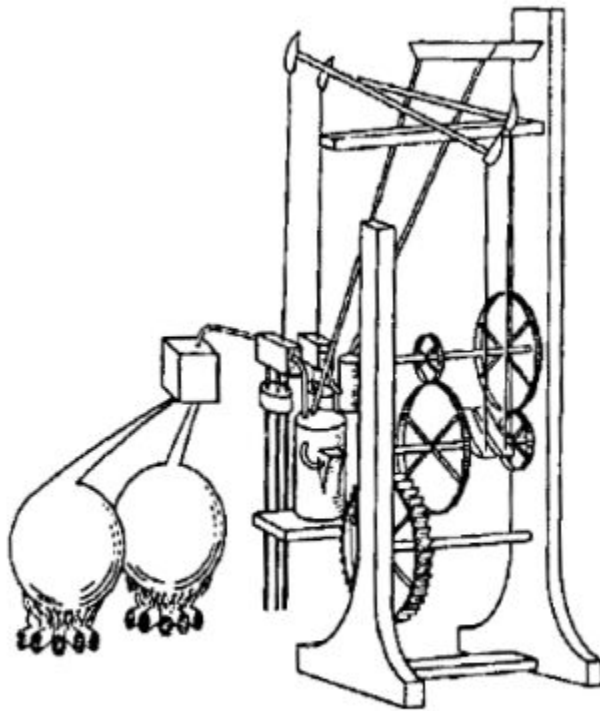

Barber's British Patent - 1791

# Samuel Langley

Langley attempted to make the first working piloted heavier-than-air aircraft. His models flew, but his two attempts at piloted flight in 1903 –just weeks before the Wrights’ success in 19 December- were not successful.

Langley began experimenting with rubber-band powered models and gliders in 1887. He built a rotating arm (functioning similar to a wind tunnel) and made larger flying models powered by miniature steam engines. His first success came on May 6, 1896 when his Number 5 unpiloted model flew half a mile after a catapult launch from a boat on the Potomac River. Aviation historians consider this to be the world's first sustained flight by

a powered heavier-than-air craft. On November 11 that year his Number 6 model flew more than 5-thousand feet.

These flights demonstrated that stability and sufficient lift could be achieved in such craft. Langley obtained a War Department grant of \$50,000 to develop a piloted airplane, which he called an "**Aerodrome**" (coined from Greek words roughly translated as "air runner"). Langley hired Charles M. Manly as engineer and test pilot.

The full-scale Aerodrome was designed, built and powered by gasoline, internal combustion engine. This engine had far more power than did the engine for the Wright brothers' first airplane—50 hp compared to 12 hp.

The piloted machine had wire-braced tandem wings (one behind the other). It had a Pénauud tail for pitch and yaw control but no roll control, depending instead on the dihedral angle of the wings, like the models, for maintaining roughly level flight. In contrast to the Wright brothers' design of a controllable airplane that could fly against a strong wind and land on solid ground, Langley sought safety by practicing in calm air over water, the Potomac River. This required a catapult for launching. The craft had no landing gear, the plan being to crash into the water after demonstrating flight.

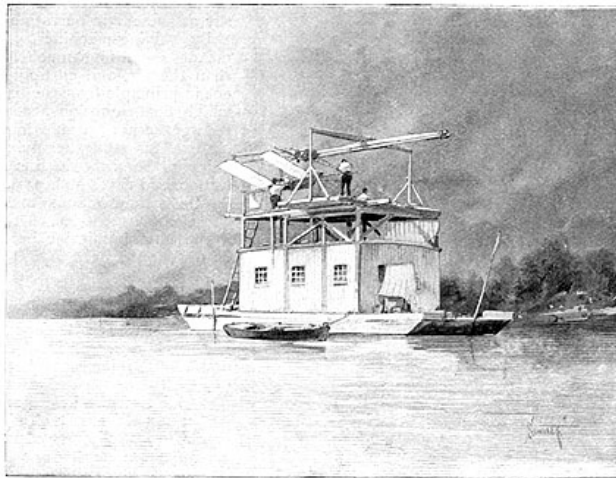

Langley Aerodrome Mounted On the  
overhead launching apparatus atop a house-boat, Potomac River - 1897

Langley gave up the project after two crashes on take-off on October 7 and December 8, 1903. Manly was recovered unhurt from the river. The Aerodrome was heavily modified and flown a few hundred feet by Glenn Curtiss in 1914.

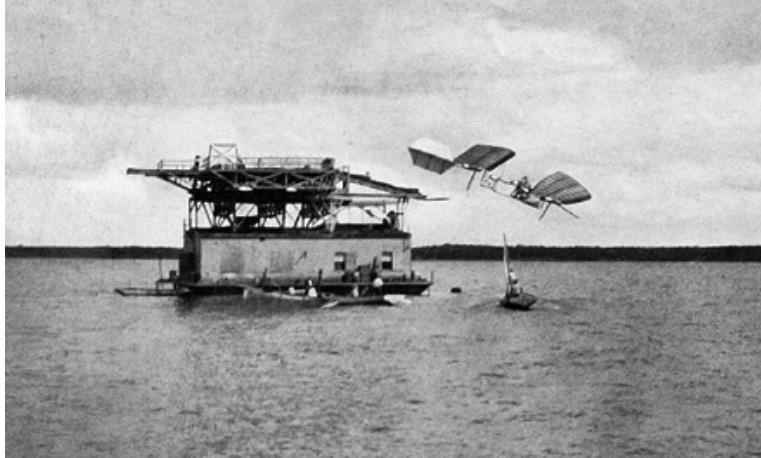

First failure of the manned Aerodrome, Potomac River, Oct. 7, 1903

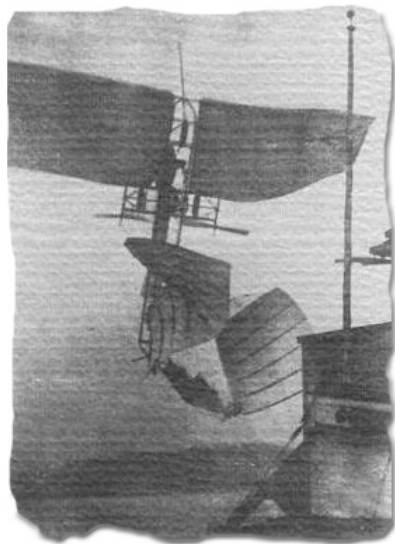

*Second failure of the Langley Aerodrome* December 8, 1903

**Wright brothers** (Wilbur 1867-1912) and (Orville 1871-1948) - Inventors of the first practical airplane

**Their achievements include:**

**1-Design and built three gliders (I, II and III)**

### 1901 Wright Glider

**Specifications**

Span: 22'  
 Length: 14'  
 Chord: 7'  
 Camber: 1/12, later adjusted to 1/19  
 Wing area: 290 sq. ft.  
 Elevator area: 18 sq. ft.  
 Weight: 98 lb.  
 Longest flight: 389'  
 Best time: Unknown

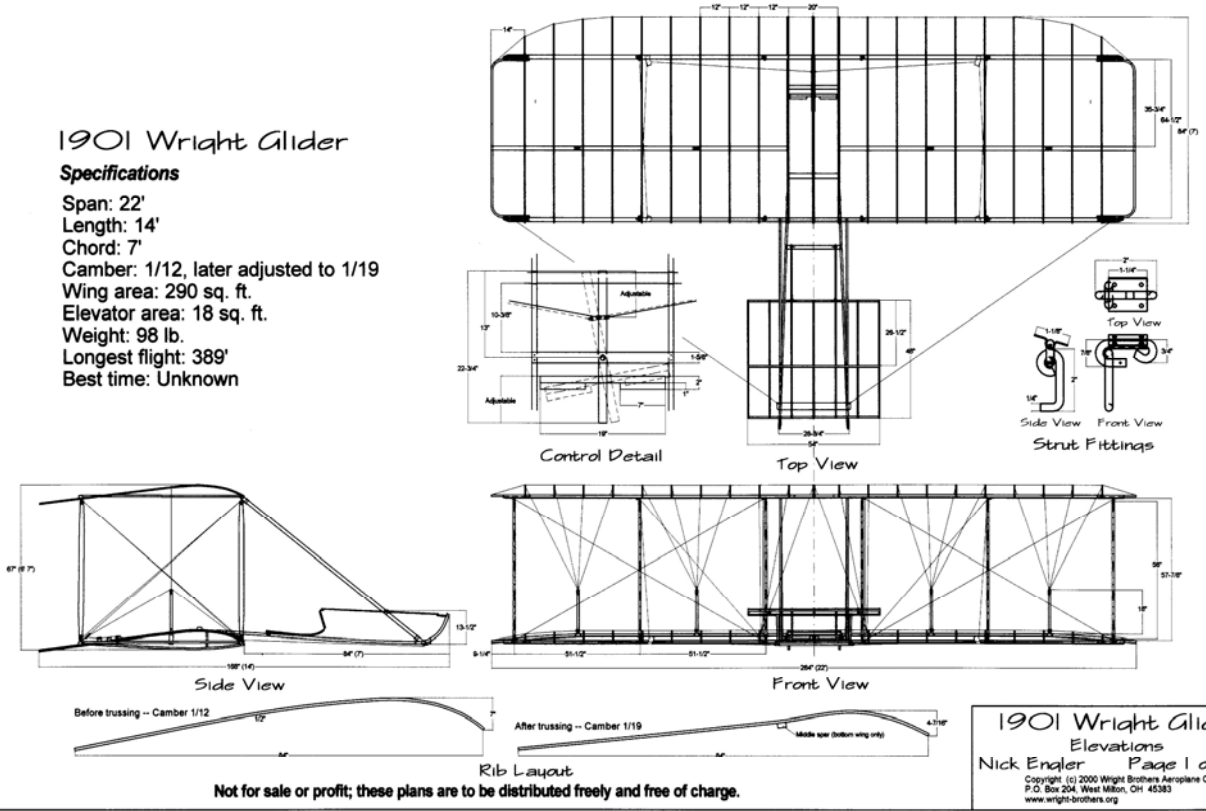

Glider-I



Glider- II

Glider I (17-ft wing span and horizontal elevator in front of the wings) was flown in October 1900 in the area around Kitty Hawk, North Carolina. Few piloted flights were made.

Glider II (22-ft wing span) was tested in July- August 1901 mostly manned flights with either Wilbur or Orville lying prone on the bottom wing facing into the wind.

Glider III (32-ft 1-in wing span) was constructed in August-September 1902. They added a movable vertical rudder behind the wings. They made over 1000 perfect flights and set a distance record of 622.5 ft in 26 seconds

## **2- Design of their own wind tunnel to test different wing sections for their gliders and propellers**

They tested 200 different airfoil sections. They designed a force balance to measure accurately lift and drag forces.

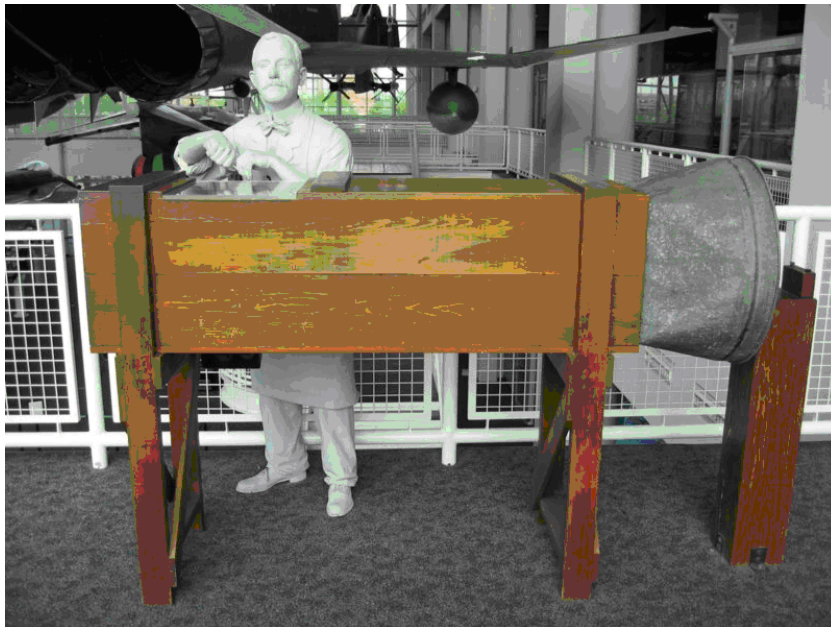

**Wind Tunnel**

## **3- Design and built light weight engine; namely a gasoline four stroke four cylinder internal combustion engine**

The engine consisted of four cylinders like the one shown below, with each piston connected to a common crankshaft. The crankshaft was connected to two counter-rotating propellers which produced the thrust necessary to overcome the drag of the aircraft.

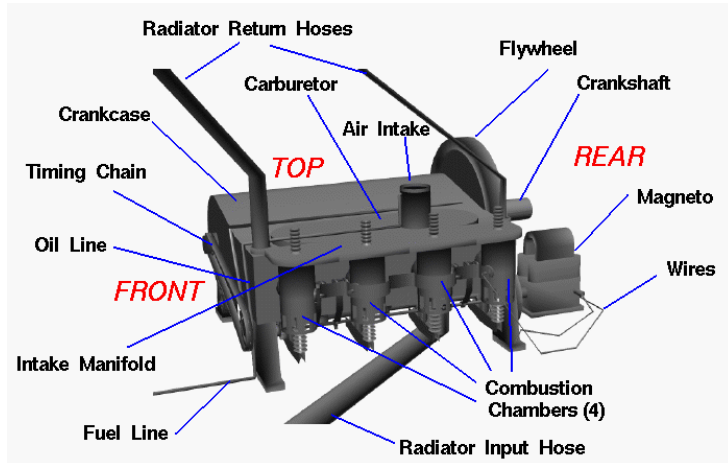
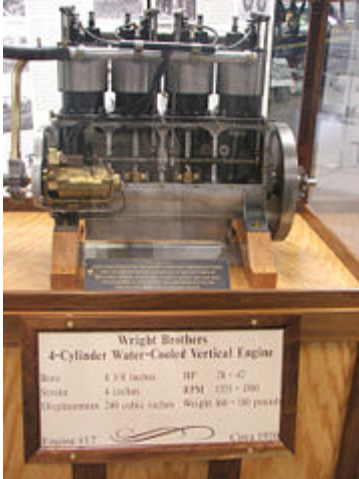

**Wrights' engine**

#### **4- Design and built of long twisted propellers**

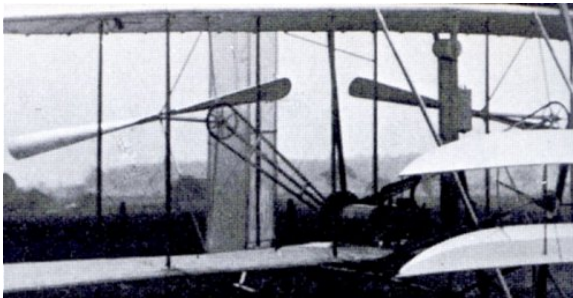

Original form of Wright propellers

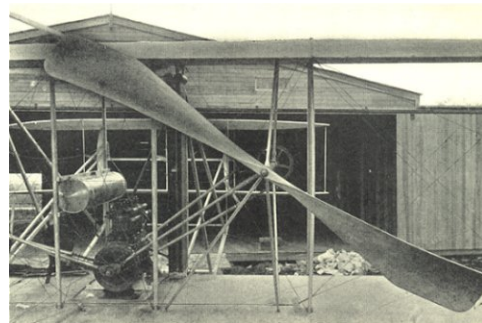

Later form of Wright propellers (1910)

#### **5- Design of transmission system (chains and sprockets) to transfer power from the engine to the propellers**

#### **6- Design and built the Flyer I**

Flyer I had a wing span of 40 ft 4 in and had a double rudder behind the wing and double elevator in front of the wing. The Wright gasoline engine drove two pusher counter rotating propellers by means of bicycle-type chains. The wing area was 505 square feet. Total airplane weight with pilot was 750 lb. Thus it achieved the first powered flight under pilot's control on December 17, 1903 with Orville as a pilot. The plane began to move along a 60-ft launching rail on level ground. Wilbur Wright ran along the right side of the plane, supporting wing tip. Near the end of the rail, the plane lifted into air. It flew unevenly, suddenly rose to about 10 ft in a steep climb, stalled, then thumped back to the ground. The flight continued for 12 s and covered 120 ft.



Three more flights were made during the morning; the last covered 825 ft and remained in the air for 59 seconds.

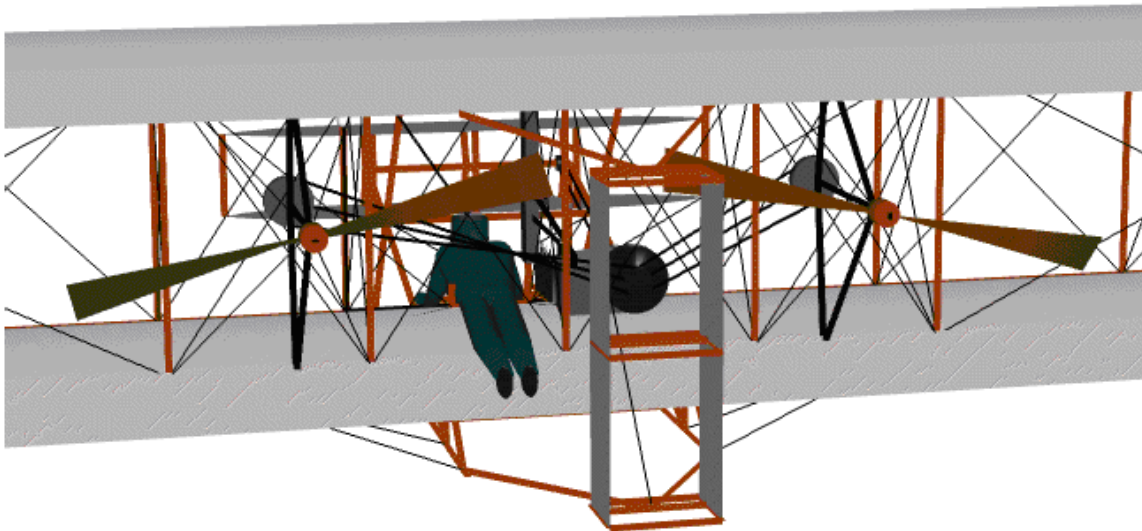

After that epoch event the Wright brothers did not stop. They designed in 1904 their Flyer II having more powerful and efficient engine. They made 80 flights during 1904 including the first circular flight. The longest flight lasted 5 min and 4 s traversing 2.75

mi. Further developments led to the Wright Flyer III in June 1905. Both of the double rudder and biplane elevator were made larger. They used also new improved rudder. This Flyer III is considered the first practical airplane in history. It made over 40 flights during 1905. The longest flight covered 24 mi and lasted for 38 min and 3 s.

Between 1905 and 1908, they designed a new flying machine; Wright type A, which allowed two persons to be seated upright between the wings. They also built at least six engines. Thus their Wright type A was powered by a 40 hp engine. Wright brother met the public both in USA in 1908 with impressive demonstrations by Orville for the army and public show at Hunaudieres close to Le Mans in France by Wilbur.

### **Frank White (1907-1996)**

Whittle is considered by many to be the father of jet engine. In January 1930, Frank Whittle submitted his patent application for a jet aircraft engine. The patent was granted in 1932. However he received very little encouragement from the Air Ministry or industry. After receiving support from investment bankers, Power Jets was established in 1936 and Whittle was assigned to the company to work on the design and development of his first jet engine.

The first run of the experimental engine was in April 1937. This engine has a centrifugal compressor and axial flow turbine. Many problems were encountered. Some were solved during the next year and the experimental engine was reconstructed several times. The resulting engine with ten combustion chambers performed well. In June 1939, the Air Ministry was finally convinced of the merits of Whittle's invention and decided to have a flight engine. Thus, the first Whittle flight engine was built and was called the Power Jet W.1. The W.1 turbojet engine was designed to produce 1,240 lbs at 17,750 rpm. The Air Ministry also decided to have the Gloster Aircraft Company build an experimental airplane called the E28/39. The aircraft was completed in March 1941 and the engine in May 1941. On May 15, 1941, the Gloster E28/39 powered with W.1 Whittle engine; took off from Cranwell at 7.40 pm, flying for seventeen minutes and reaching a maximum speed of around 545 km/h (340 mph). Within days it was reaching 600 km/h (370 mph) at 7600 meters.

---

1.6- Which engines have no moving parts?

#### **Solution**

- a. Ramjet engines
  - b. Scramjet engines
- 

1.7- What is the type of engine that powered most of today's airliners?

#### **Solution**

Turbofan engines are used in most or nearly all present aircrafts.

**a. Civil transport aircraft**

Two-or three spool forward unmixed turbofan

**b. Military aircrafts**

Two spool forward mixed turbofan

---

1.8- What is the type of engine would used in a helicopter?

**Solution**

Turboshaft engines are used in helicopters

---

1.9- How is a turboprop different from a turbojet?

**Solution**

<b><u>Engine</u></b>	<b><u>Turbojet</u></b>	<b><u>Turboprop</u></b>
Application	Old civil and military plane	Commuter ( or regional aircraft), Cargo and long range planes
Speed	Subsonic for civil transport and subsonic-supersonic for military aircrafts	300-500 mph
Layout	Intake-compressor (s)- combustion chamber- turbine (s)-nozzle	Similar to turbojet except it has a propeller and heavy gearbox

Afterburner	Only in military aircrafts	Never available
Noise	Medium	High
Popular engine	GE J47 (more than 35,000 engine) RR Avon MK524	Pratt & Whitney of Canada PT6
Popular aircraft	Comet powered by Rolls-Royce Avon Mk 524 turbojets	Lockheed C-130 Hercules
Performance	Limited by range and endurance	- High shaft power/weight -Altitude ranges from 18,000 to 30,000 ft
Thrust generation	Difference between jet exhaust (mass and velocity) and inlet air (mass and velocity) a pressure thrust is developed for choked nozzle	Gas turbine drives the propeller which generates most of the thrust (85%), while the exhaust nozzle generates a small portion of thrust (15%)

---

1.10- List the names of some Chinese aircrafts and engines.

**Solution**

Here some Chinese aircrafts are listed for different types of power plants:

a- HS - Hou Sai (Piston/Propeller Aircraft Engines):

=====

HS-6: a Copy of Ivchenko AI-14R, used by CJ-6, Y-11

b- PF - (Jet/Turbo Aircraft Engines):

=====

PF-1: a copy of Klimov VK-1F, used by JJ-1

c- WP - Wopen (TurboJet Aircraft Engines):

=====

WP-6		Turbojet engine, used in Q-5, J-12
WP-7A	Chengdu	Turbojet engine, used in J-8 (based on R-11)
WP-7BM	Chengdu	Turbojet engine, used in J-7M
WP-8		
WP-9		
WP-10		
WP-11		Turbojet engine, used in CH-1
WP-12		
WP-13A	Liyang	Turbojet engine, used in J-7III, J-8-II (based on WP-7)
WP-13A-II	Liyang	Turbojet engine, used in J-7III, J-8-II
WP-13F		Turbojet engine, used in F-7M, F-7MF, F-7MG

d- WJ - Turboprop Aircraft Engines:

=====

WJ-5A-1 Dongan TurboProp engine, used in SH-5

e- WS - Turbofan Aircraft Engines:

=====

WS-5		
WS-6	Wopen	Turbofan engine
WS-6A	Shenyang	Turbofan engine, used in H-7/JH-7
WS-9	Xian	Chinese-built RR Spey TurboJet, used in H-7/JH-7/FBC-1

f- WZ - Turboshaft Aircraft Engines):

=====

WZ-5 Turboshaft engine, used in Z-6

**[Here more details about some Chinese engines](#)**

## **Q-5**

Q-5, which export version being designated A-5 is a single-seat, twin-engine supersonic fighter developed by the Nanchang Aircraft Company of China. It is used mainly to assist ground troops in attacking concentrated targets on land, key transportation points and ships near the coast. It can also intercept and fight enemy aircraft. It has two WP-6 after burning type of turbojet engines. Its maximum takeoff load is 11,300 kg.

## **J-10**

The design program of J-10 in the 1990s featured a large amount of new technologies, including composite materials, computerized flight-control (“fly-by-wire”) system, advanced radar and cockpit electronics, computer-aided design and manufacturing (CAD/CAM), etc.

The J-10 made its first successful flight on 22 March 1998. Further test and evaluation of the aircraft was carried out in 2004. The first operational J-10 fighter regiment was activated in Yunnan Province on 13 July 2004. The Chinese state media only announced the J-10 in November 2006, nearly two years after it entered service.

The J-10 is powered by a 122.5kN (12,500kg or 27,557 lb) thrust Salyut AL-31FN turbofan engine, with 4,500kg internal fuel. The aircraft also features a digital fuel management system. The combat radius of the aircraft was estimated to be 550~600km, but it could be extended to over 1,000km once the aircraft is added with the aerial refueling capability. The aircraft can be fitted with a fixed aerial refueling probe on the starboard side of the cockpit.



**FC-1**

The **Joint Fighter-17 (JF-17) Thunder**, also known as the **Fighter China-1 (FC-1) Fierce Dragon** (梟龍) in China, is a single-seat multirole fighter aircraft developed by China and Pakistan. The first two aircraft were delivered to the Pakistan Air Force on 2007-03-12. Power plant is a low bypass ratio turbofan (bypass ratio of 0.57) and thrust of 86.37 for operative afterburner.

---

1.11- Identify engines available for the following aircraft

B787, B777, B767, B757, B747-200, B747-400, MD80, B737- 800/500, A310, A320, A330, A340, A380, A350, the Sukhoi Su-9, Tupolev Tu-128P, DC-8, U-2 spy, Shenyang J-8, Rafale, Mirage 5, Swedish Ja-37 Viggen, Mig 23, Mig 29, Tornado ADV, Eurofighter V-22 Osprey, AN-225, Convair 580, Fairchild F-27, Lockheed L100 Hercules, Cessna Citation II, Gulfstream Aerospace (IAI) G100, Bombardier Canadair 415, Bell 412, Sikorsky S-58, Lockheed Martin F-117A Nighthawk, Lockheed Martin P-3 Orion, Mi-12, ATR 42-500, ATR 72, Panavia Tornado, AH-64 A Apache, SAAB 340B, BOMBARDIER Q400 DASH 8, MiG-AT, Rutan Voyager

**Solution**

<i>Airplane name</i>	<i>Engine</i>
<i>B787</i>	Turbofan engines (General Electric GENx or RR Trent 1000)
<i>B777</i>	<i>Turbofan engine</i> (PW 4090 -RR 895-GE90-94B)
<i>B767</i>	<i>Turbofan engine</i>
<i>B757</i>	<i>Turbofan engine</i> (Rolls-Royce RB211-Pratt & Whitney PW2037, PW2040, or PW2043)

<i>B747-200,B747-400</i>	<i>Turbofan engine( PW JT9D-7R4G2 GE CF6-50E2- RR RB211-524D4)</i>
<i>MD80</i>	<i>Turbofan engine. <u>PW JT8, V2500</u></i>
<i>B737-800</i>	<i>Turbofan engine</i>
<i>B737-500</i>	<i>Turbofan engine</i>
<i>A310</i>	<i>High-bypass turbofan. <u>JT9R4, CF6, PW4000</u></i>
<i>A320</i>	<i>Turbofan engine. <u>CFM56-5A</u></i>
<i>A330</i>	<i>Turbofan engine <u>.CF6</u></i>
<i>A340</i>	<i>Turbofan engine <u>.CFM56-5C</u></i>
<i>A380</i>	<i>Turbofan engine (GP7270 (A380-861) Trent 970/B(A380-841) Trent 972/B (A380-842)</i>
<i>A350</i>	<i>Turbofan engine. <u>GENx</u></i>
<i>The Sukhoi Su-9</i>	<i>Turbojets. <u>2× Tumanskii RD-10, Lyulka AL-7 turbojet</u></i>
<i>Tupolev Tu-128-p</i>	<i>Turbojet engines. <u>2Lyulka AL-7F-2</u></i>
<i>DC-8</i>	<i>Turbofans. <u>JT3D3</u></i>
<i>U-2 Spy</i>	<i>General Electric F118-101 turbojet</i>
<i>Shenyang J-8</i>	<i>WP-13A turbojet</i>
<i>Rafale</i>	<i>Turbofan engine <u>M88-2 engines</u></i>
<i>Mirage 5</i>	<i>Turbojet engine <u>1× SNECMA Atar 09C</u></i>
<i>Swedish Ja-37Viggen</i>	<i>Afterburning turbofan, <u>16,200 lbf dry, 28,110 lbf afterburning 1× Volvo RM8B</u></i>
<i>Mig23</i>	<i>Turbojet. <u>one Khachaturov R-35-300 afterburning</u></i>
<i>Mig29</i>	<i>Turbofan. <u>RD-33 high performance</u></i>
<i>Tornado ADV</i>	<i>Turbofans.<u>2× Turbo-Union RB199-34R Mk 103 afterburning</u></i>
<i>Eurofighter</i>	<i>Turbofans.<u>2× Eurojet EJ200 afterburning</u></i>
<i>V-22 Ospery</i>	<i>2× Rolls-Royce Allison Rolls-Royce T406 (AE 1107C-Liberty) turboshafts, 6,150 hp (4,590 kW) each</i>
<i>An-ss5</i>	<i>Turbofan engine <u>6× ZMKB Progress D-18,</u></i>
<i>Convair 580</i>	<i>Turbo-propeller. <u>2 Allison 501 D13D engines</u></i>

<i>Fairchild F-27</i>	<i>Turbo-propeller</i>
<i>Lockheed L100 Hercules</i>	<i>Turboprops. 4 × Allison T56-A-15</i>
<i>Cessna Citation II</i>	<i>Turbofans. 2 × Pratt &amp; Whitney Canada JT15D4B</i>
<i>Gulfstream Aerospace (IAI) G100</i>	<i>Turbofan engines two Honeywell TFE731-40R</i>
<i>Bombardier Canadair 415</i>	<i>Turboprops. PW123AF</i>
<i>Bell 412</i>	<i>PT6T-3D Twin Pac engine</i>
<i>Sikorsky S-58</i>	<i>PT6T-6 Twin engine</i>
<i>Lockheed Martin F-117A Nighthawk</i>	<i>Turbofans 2 × General Electric F404-F1D2</i>
<i>Lockheed Martin P-3 Orion</i>	<i>Four Allison T56-A-14</i>
<i>Mi-12</i>	<i>Turboshaft. engine: 4 x D-25VF</i>
<i>ART 42-500</i>	<i>Turbofan 2 x PW124 @ 2160 SHP (ATR 72-200). 2 x PW127 @ 2475 SHP (ATR 72-210). 2 x PW127F @ 2475 SHP (ATR 72-500).</i>
<i>Panavia Tornado</i>	<i>Afterburning Turbofans 2 × Turbo-Union RB199-34R Mk 103</i>
<i>Ah64 A Apache</i>	
<i>SAAB 340B</i>	<i>Turboprops General Electric CT7-9B.</i>
<i>BOMBARDIER Q400 DASH8</i>	<i>Turboprops PW150A</i>
<i>Mig-At</i>	<i>Turbofan engines Two Turbomeca-SNECMA Larzac 04-R20</i>
<i>Rutan Voyager</i>	<p>Voyager completing the first non-stop, non-refueled flight around the world by an airplane. Its flight of 26,366 statute miles lasted 9 days, 3 minutes, and 44 seconds</p> <p>It had front and rear propellers, powered by separate engines. The rear engine, a water-cooled Teledyne Continental IOL-200, was planned to be operated</p>

	<p>throughout the flight.  The front engine, an air-cooled Teledyne Continental O-240, was operated to provide additional power for takeoff and the initial part of the flight at heavy weights.</p>
--	--

1.12- State the type of each of the following engine and mention the name of some aircraft they are powering:

F-100, F-101, F-110, RB-199, RB 211, Nene, JT 8D, RR Pegasus T56, V2500, CFM56, GE90, Lyulka AL-7, JT9, CF6, TFE 731, TPE331, TV3 VK-1500, AL-31 F, Trent 700, Olympus 593, T700-GE, PW100, SM146, DR-1700, CF34-8, Ha 102

**Solution**

**First a quick list is given:**

**a) Turbojet Engine**

Nene, Lyulka AL-7, Olympus 593,

**b) Turbofan Engine**

**F-100, F-101, F-110, RB 199, RB 211, JT 8D, RR Pegasus, V 2500, CFM 56, GE 90, JT9, CF6, TFE 731, Trent 700, AL-31 F, SM146, CF34-8**

**c) Turboprop Engine**

T 56, TPE331, PW100,

**d) Turboshaft Engine**

TV3 VK-1500, T700-GE,

**e) Piston Engine**

Ha 102 (Mitsubishi 14-cylinder radial engine)

**Full details are given in the following table**

Engine name	Type	Aircraft
-------------	------	----------

F-100	Turbofan engine	F-14 F-16
F-101	Turbofan engine	B-1B
F-110	Turbofan engine and adding different fan and afterburner packages to tailor engine performance to the desired aircraft application.	F-14 F-15 F-16
RB-199	jet engine twin spool	Concorde
RB-211	Turbofan engine	Boeing 747, 757 and 767, as well as the Russian Tupolev Tu-204 airliner
NENE	Jet engine	The Nene was used to power the first civil jet aircraft, a modified Vickers Viking
JT8D	Turbofan jet engine	<p><u>JT8D-7</u></p> <p>operating on the Boeing 727-100 and some 727-200 aircraft</p> <p><u>JT8D-9</u></p> <p>operating on the Boeing 737-100, 737-200 and McDonnell Douglas DC-9-30 aircraft</p> <p><u>JT8D-9A</u></p> <p>which is another version of the JTD8-9, operating on the Boeing 737-100, 737-200 and McDonnell Douglas DC-9-30 aircraft</p> <p><u>JT8D-11</u></p> <p>operating on the Boeing 727-200 and McDonnell Douglas DC-9-40 aircraft</p> <p><u>JT8D-15</u></p> <p>operating on the Boeing 727-200 aircraft, Dassault Mercure and McDonnell Douglas DC-9-30, DC-9-40 and McDonnell Douglas DC-</p>

		<p>9-50 aircraft</p> <p><u>JT8D-17</u></p> <p>operating on the McDonnell Douglas YC-15</p> <p><u>JT8D-17R &amp; S</u></p> <p>operating on the Boeing 727-200 Advanced aircraft and McDonnell Douglas DC-9-50 aircraft</p> <p><u>JT8D-209</u></p> <p>used on McDonnell Douglas MD-81</p> <p><u>JT8D-217A/C</u></p> <p>used to power the McDonnell Douglas MD-82/MD-88 and MD-87</p> <p><u>JT8D-219</u></p> <p>used to power the McDonnell Douglas MD-83</p> <p><u>Variant of the JT8D-219</u></p> <p>Is to be used on the proposed Aerion SBJ.</p>
RR Pegasus T56	Turboprop	American helicopters and fixed-wing aircraft
V2500	Turbofan engine	for the Airbus A319 family
CFM56	Turbofan engine	<p><u>CFM56-2</u></p> <p>KC-135R, C-135R, E-3, KE-3A, E-6A, DC-8 Super 70</p> <p><u>CFM56-3</u></p> <p>Boeing 737-300/-400/-500</p> <p><u>CFM56-5A</u></p> <p>Airbus A319 and A320</p> <p><u>CFM56-5B</u></p> <p>Airbus A318, A319, A319CJ, A320</p>

		and A321 <u>CFM56-5C</u> Airbus A340-200 and A340-300 <u>CFM56-7B</u> Boeing 737-600/-700/-800/-900/BBJ
GE90	Turbofan engine	Boeing 777-200 Boeing 777-200ER Boeing 777-200LR Boeing 777-300ER
Lyulka AL-7	Afterburning turbojet	Tu-128P 'Fiddler' Beriev M-10G jet flying boat Su-7B and Su-9 'Fishpot'
JT9	High-bypass turbofan	B-747, B-767, Airbus A300, A310 and McDonnell Douglas DC-10 aircraft. For JT9D-7R4 installed in A300-600, A310 and 767
CF6	Turbofan engine	Airbus A300/A310/A330 Boeing 767 Boeing 747 MD-11 DC-10 E-4 KC-10 Boeing 767 Tanker Boeing 767 AWACS Airbus 330 Tanker CX Japanese transport
TFE731	Turbofan engine	<u>TFE731-2</u>  AIDC AT-3  CASA C-101  Dassault Falcon 10  FMA IA 63 Pampa

		<p>Hongdu JL-8</p> <p>Learjet 31</p> <p>Learjet 35</p> <p>Learjet C-21</p> <p><u>TFE731-3</u></p> <p>British Aerospace BAe 125 Series 700</p> <p>Boeing Skyfox</p> <p>Cessna Citation III</p> <p>Cessna Citation VI</p> <p>Learjet 55</p> <p>Lockheed 731 Jetstar / Jetstar II</p> <p><u>TFE731-4</u></p> <p>Aero L-139 (prototype only)</p> <p>Cessna Citation VII</p> <p><u>TFE731-5</u></p> <p>Raytheon Hawker 800/850XP</p> <p><u>TFE731-20</u></p> <p>Learjet 40</p> <p>Learjet 45</p> <p><u>TFE731-40</u></p> <p>C-38 Courier</p> <p>Gulfstream G100/G150 (formerly</p>
--	--	---