

Solutions Manual

Contact me in order to access the whole complete document. Email: solution9159@gmail.com
WhatsApp: <https://wa.me/message/2H3BV2L5TTSUF1> Telegram: <https://t.me/solutionmanual>

Solutions to Chapter 2 Problems

S.2.1

- (a) Vectors representing the 10 and 15 kN forces are drawn to a suitable scale as shown in Fig. S.2.1. Parallel vectors AC and BC are then drawn to intersect at C. The resultant is the vector OC which is 21.8 kN at an angle of 23.4° to the 15 kN force.

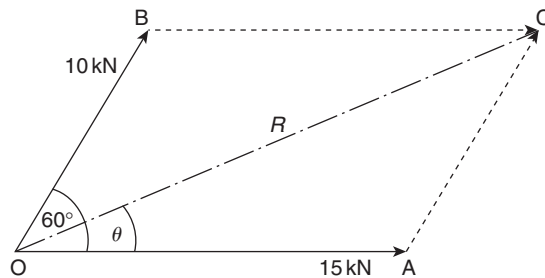

FIGURE S.2.1

- (b) From Eq. (2.1) and Fig. S.2.1

$$R^2 = 15^2 + 10^2 + 2 \times 15 \times 10 \cos 60^\circ$$

which gives

$$R = 21.8 \text{ kN}$$

Also, from Eq. (2.2)

$$\tan \theta = \frac{10 \sin 60^\circ}{15 + 10 \cos 60^\circ}$$

so that

$$\theta = 23.4^\circ.$$

S.2.2

- (a) The vectors do not have to be drawn in any particular order. Fig. S.2.2 shows the vector diagram with the vector representing the 10 kN force drawn first.

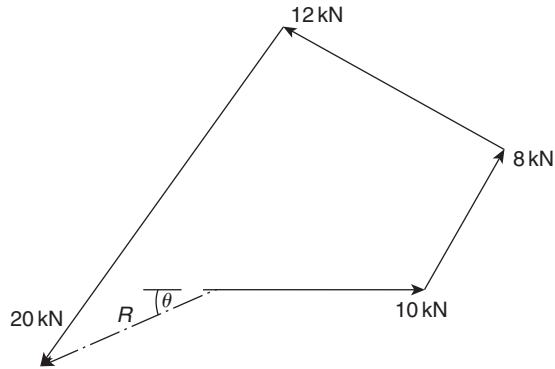

FIGURE S.2.2

The resultant R is then equal to 8.6 kN and makes an angle of 23.9° to the negative direction of the 10 kN force.

- (b) Resolving forces in the positive x direction

$$F_x = 10 + 8 \cos 60^\circ - 12 \cos 30^\circ - 20 \cos 55^\circ = -7.9 \text{ kN}$$

Then, resolving forces in the positive y direction

$$F_y = 8 \cos 30^\circ + 12 \cos 60^\circ - 20 \cos 35^\circ = -3.5 \text{ kN}$$

The resultant R is given by

$$R^2 = (-7.9)^2 + (-3.5)^2$$

so that

$$R = 8.6 \text{ kN}$$

Also

$$\tan \theta = \frac{3.5}{7.9}$$

which gives

$$\theta = 23.9^\circ.$$

S.2.3 Initially the forces are resolved into vertical and horizontal components as shown in Fig. S.2.3.

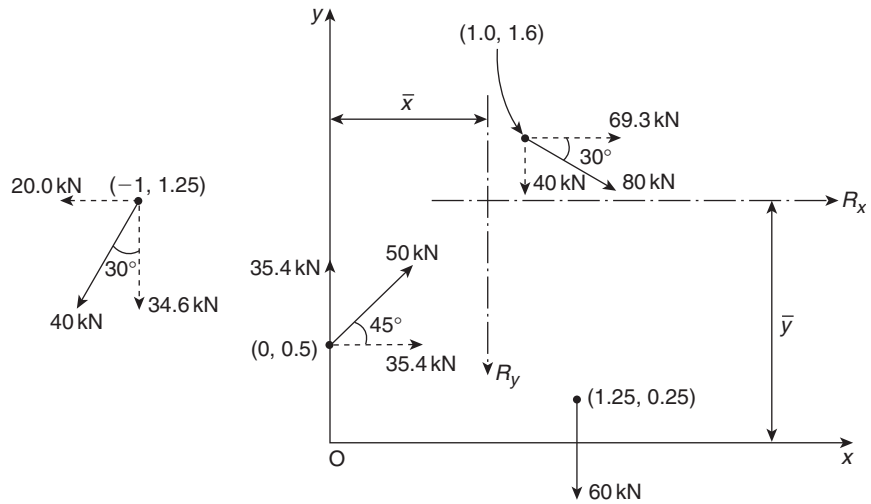

FIGURE S.2.3

Then

$$R_x = 69.3 + 35.4 - 20.0 = 84.7 \text{ kN}$$

Now taking moments about the x axis

$$R_x \bar{y} = 35.4 \times 0.5 - 20.0 \times 1.25 + 69.3 \times 1.6$$

which gives

$$\bar{y} = 1.22 \text{ m}$$

Also, from Fig. S.2.3

$$R_y = 60 + 40 + 34.6 - 35.4 = 99.2 \text{ kN}$$

Now taking moments about the y axis

$$R_y \bar{x} = 40.0 \times 1.0 + 60.0 \times 1.25 - 34.6 \times 1.0$$

so that

$$\bar{x} = 0.81 \text{ m}$$

The resultant R is then given by

$$R^2 = 99.2^2 + 84.7^2$$

from which

$$R = 130.4 \text{ kN}$$

Finally

$$\theta = \tan^{-1} \frac{99.2}{84.7} = 49.5^\circ.$$

S.2.4

- (a) In Fig. S.2.4(a) the inclined loads have been resolved into vertical and horizontal components. The vertical loads will generate vertical reactions at the supports A and B while the horizontal components of the loads will produce a horizontal reaction at A only since B is a roller support.

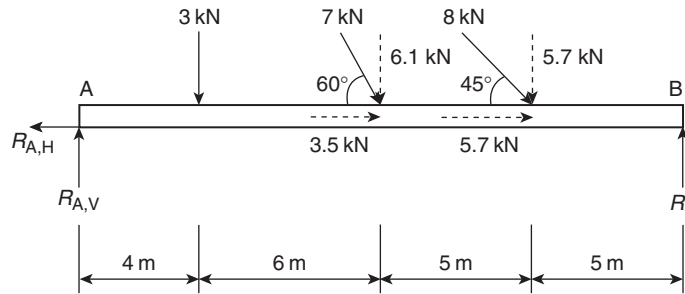

FIGURE S.2.4(a)

Taking moments about B

$$R_{A,V} \times 20 - 3 \times 16 - 6.1 \times 10 - 5.7 \times 5 = 0$$

which gives

$$R_{A,V} = 6.9 \text{ kN}$$

Now resolving vertically

$$R_{B,V} + R_{A,V} - 3 - 6.1 - 5.7 = 0$$

so that

$$R_{B,V} = 7.9 \text{ kN}$$

Finally, resolving horizontally

$$R_{A,H} - 3.5 - 5.7 = 0$$

so that

$$R_{A,H} = 9.2 \text{ kN}$$

Note that all reactions are positive in sign so that their directions are those indicated in Fig. S.2.4(a).

- (b) The loads on the cantilever beam will produce a vertical reaction and a moment reaction at A as shown in Fig. S.2.4(b).

Resolving vertically

$$R_A - 15 - 5 \times 10 = 0$$

which gives

$$R_A = 65 \text{ kN}$$

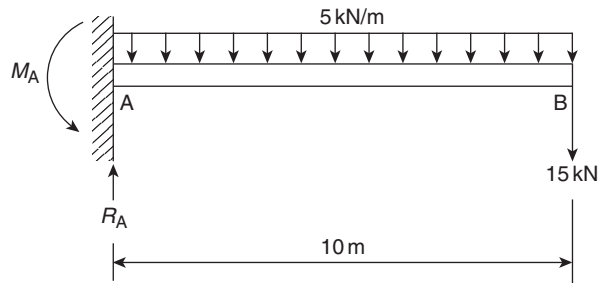

FIGURE S.2.4(b)

Taking moments about A

$$M_A - 15 \times 10 - 5 \times 10 \times 5 = 0$$

from which

$$M_A = 400 \text{ kN m}$$

Again the signs of the reactions are positive so that they are in the directions shown.

- (c) In Fig. S.2.4(c) there are horizontal and vertical reactions at A and a vertical reaction at B.

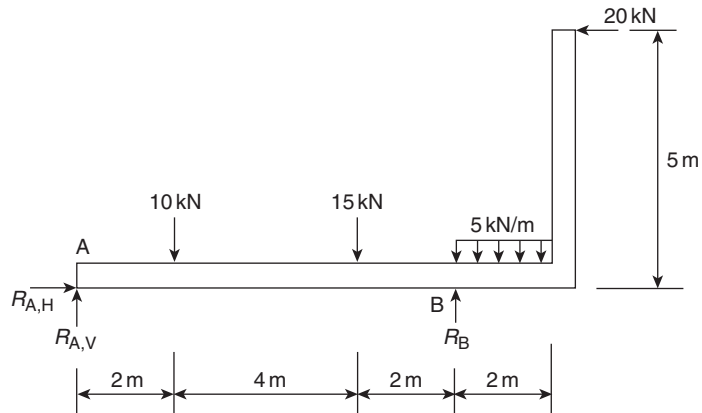

FIGURE S.2.4(c)

By inspection (or by resolving horizontally)

$$R_{A,H} = 20 \text{ kN}$$

Taking moments about A

$$R_B \times 8 + 20 \times 5 - 5 \times 2 \times 9 - 15 \times 6 - 10 \times 2 = 0$$

which gives

$$R_B = 12.5 \text{ kN}$$

Finally, resolving vertically

$$R_{A,V} + R_B - 10 - 15 - 5 \times 2 = 0$$

so that

$$R_{A,V} = 22.5 \text{ kN.}$$

- (d) The loading on the beam will produce vertical reactions only at the supports as shown in Fig. S.2.4(d).

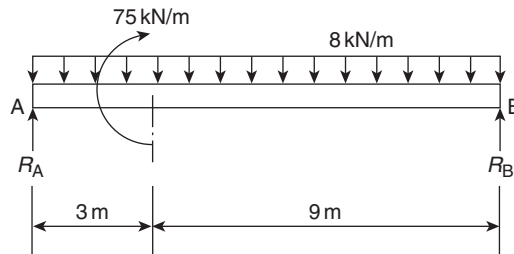

FIGURE S.2.4(d)

Taking moments about B

$$R_A \times 12 + 75 - 8 \times 12 \times 6 = 0$$

Hence

$$R_A = 41.8 \text{ kN}$$

Now resolving vertically

$$R_B + R_A - 8 \times 12 = 0$$

so that

$$R_B = 54.2 \text{ kN.}$$

S.2.5

- (a) The loading on the truss shown in Fig. P.2.5(a) produces only vertical reactions at the support points A and B; suppose these reactions are R_A and R_B respectively and that they act vertically upwards. Then, taking moments about B

$$R_A \times 10 - 5 \times 16 - 10 \times 14 - 15 \times 12 - 15 \times 10 - 5 \times 8 + 5 \times 4 = 0$$

which gives

$$R_A = 57 \text{ kN (upwards)}$$

Now resolving vertically

$$R_B + R_A - 5 - 10 - 15 - 15 - 5 - 5 = 0$$

from which

$$R_B = -2 \text{ kN (downwards).}$$

- (b) The angle of the truss is $\tan^{-1}(4/10) = 21.8^\circ$. The loads on the rafters are symmetrically arranged and may be replaced by single loads as shown in Fig. S.2.5. These, in turn, may be resolved into horizontal and vertical components and will produce vertical reactions at A and B and a horizontal reaction at A.

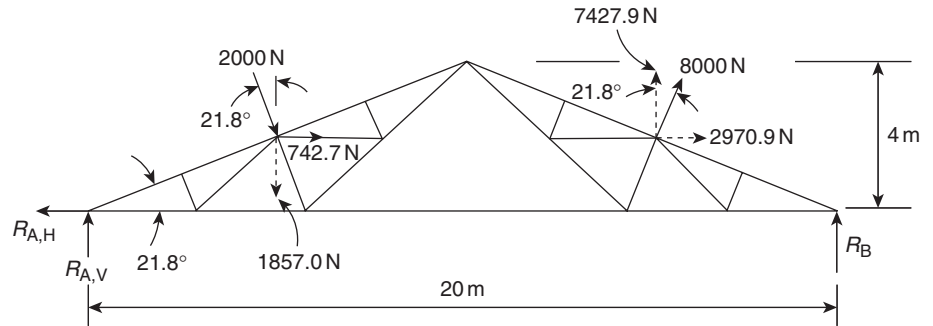

FIGURE S.2.5

Taking moments about B

$$R_{A,V} \times 20 + 742.7 \times 2 - 1857.0 \times 15 + 2970.9 \times 2 + 7427.9 \times 5 = 0$$

which gives

$$R_{A,V} = -835.6 \text{ N (downwards).}$$

Now resolving vertically

$$R_B + R_{A,V} - 1857.0 + 7427.9 = 0$$

from which

$$R_B = -4735.3 \text{ N (downwards).}$$

Finally, resolving horizontally

$$R_{A,H} - 742.7 - 2970.9 = 0$$

so that

$$R_{A,H} = 3713.6 \text{ N.}$$

Solutions to Chapter 3 Problems

S.3.1 Fig. S.3.1(a) shows the mast with two of each set of cables; the other two cables in each set are in a plane perpendicular to the plane of the paper.

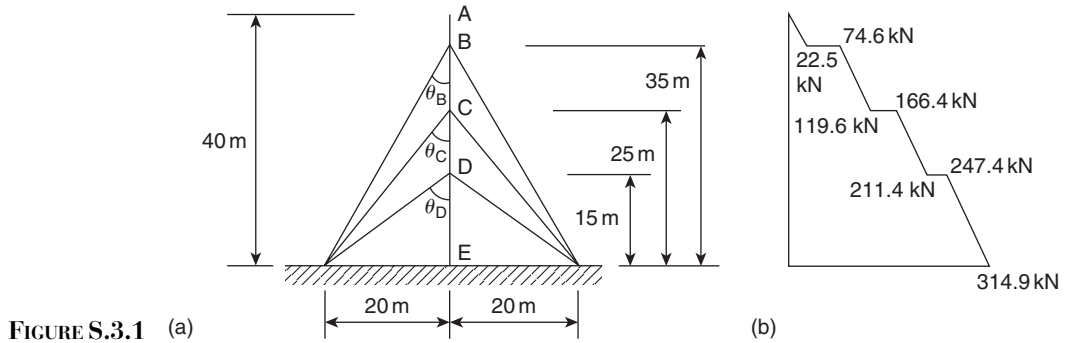

Then,

$$\theta_B = \tan^{-1}\left(\frac{20}{35}\right) = 29.7^\circ, \quad \theta_C = \tan^{-1}\left(\frac{20}{25}\right) = 38.7^\circ, \quad \theta_D = \tan^{-1}\left(\frac{20}{15}\right) = 53.1^\circ.$$

The normal force at any section of the mast will be compressive and is the sum of the self-weight and the vertical component of the tension in the cables. Furthermore the self-weight will vary linearly with distance from the top of the mast. Therefore, at a section immediately above B,

$$N = 5 \times 4.5 = 22.5 \text{ kN.}$$

At a section immediately below B,

$$N = 22.5 + 4 \times 15 \cos 29.7^\circ = 74.6 \text{ kN.}$$

At a section immediately above C,

$$N = 74.6 + 10 \times 4.5 = 119.6 \text{ kN.}$$

At a section immediately below C,

$$N = 119.6 + 4 \times 15 \cos 38.7^\circ = 166.4 \text{ kN.}$$

At a section immediately above D,

$$N = 166.4 + 10 \times 4.5 = 211.4 \text{ kN.}$$

At a section immediately below D,

$$N = 211.4 + 4 \times 15 \cos 53.1^\circ = 247.4 \text{ kN.}$$

Finally, at a section immediately above E,

$$N = 247.4 + 15 \times 4.5 = 314.9 \text{ kN.}$$

The distribution of compressive force in the mast is shown in Fig. S.3.1(b).

S.3.2 The beam support reactions have been calculated in S.2.4(a) and are as shown in Fig. S.3.2(a); the bays of the beam have been relettered as shown in Fig. P.3.2.

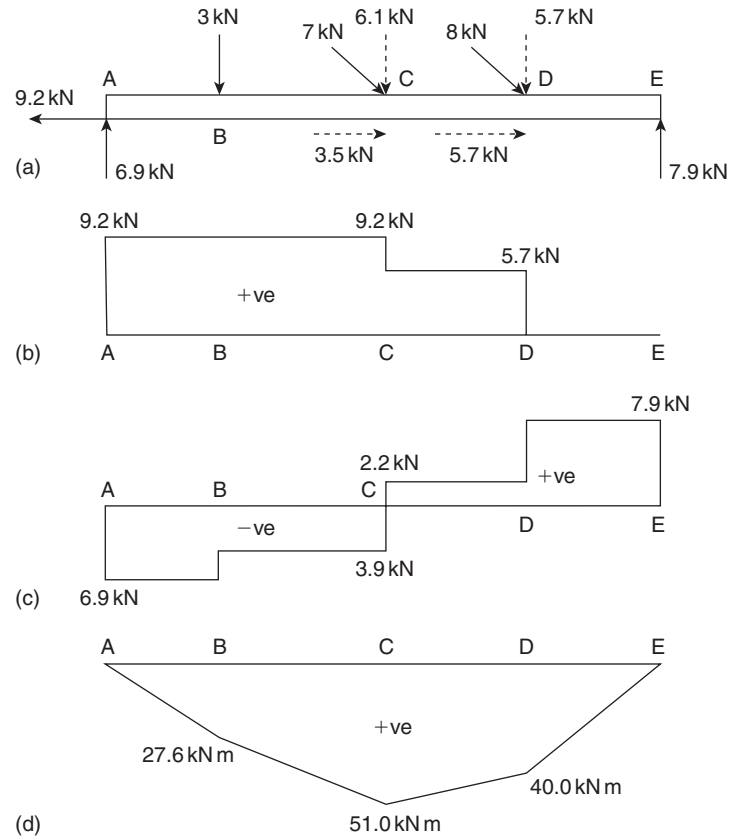

FIGURE S.3.2

Normal force

The normal force at any section of the beam between A and C is constant and given by $N_{AC} = 9.2$ kN (the vertical 3 kN load has no effect on the normal force).

Then

$$N_{CD} = 9.2 - 3.5 = 5.7 \text{ kN}$$

and

$$N_{DE} = 9.2 - 3.5 - 5.7 = 0$$

Note that N_{DE} could have been found directly by considering forces to the right of any section between D and E. The complete distribution of normal force is shown in Fig. S.3.2(b).

Shear force

The shear force in each bay of the beam is constant since only concentrated loads are involved.

At any section between A and B,

$$S_{AB} = -R_{A,V} = -6.9 \text{ kN.}$$

At any section between B and C,

$$S_{BC} = -6.9 + 3 = -3.9 \text{ kN.}$$

At any section between C and D,

$$S_{CD} = -6.9 + 3 + 6.1 = 2.2 \text{ kN.}$$

Finally, at any section between D and E,

$$S_{DE} = +R_E = 7.9 \text{ kN.}$$

The complete shear force distribution is shown in Fig. S.3.2(c).

Bending moment

Since only concentrated loads are present it is only necessary to calculate values of bending moment at the load points. Note that $M_A = M_E = 0$.

At B,

$$M_B = 6.9 \times 4 = 27.6 \text{ kN m.}$$

At C,

$$M_C = 6.9 \times 10 - 3 \times 6 = 51.0 \text{ kN m.}$$

At D,

$$M_D = 6.9 \times 15 - 3 \times 11 - 6.1 \times 5 = 40 \text{ kN m.}$$

Alternatively, $M_D = 7.9 \times 5 = 39.5 \text{ kN m}$; the difference in the two values is due to rounding off errors. The complete distribution is shown in Fig. S.3.2(d).

S.3.3 There will be vertical and horizontal reactions at E and a vertical reaction at B as shown in Fig. S.3.3(a). The inclined 10 kN load will have vertical and horizontal components of 8 and 6 kN respectively, the latter acting to the right. Resolving horizontally, $R_{E,H} = 6 \text{ kN}$. Now taking moments about E

$$R_B \times 10 - 2 \times 8 \times 11 - 8 \times 3 = 0$$

which gives

$$R_B = 20 \text{ kN}$$

Resolving vertically

$$R_{E,V} + R_B - 2 \times 8 - 8 = 0$$